

# **MSD** **IGNITION** **INSTALLATION INSTRUCTIONS**

## **Pro-Billet Late Model**

### **Ford Distributors**

**5.0L, 1986-1993, PN 8456**

**5.0L, 1994-1995, PN 8455**

**351W (non-roller cam), PN 8453**

**351W (with hydraulic roller cam), PN 8452**

**351W (with hydraulic roller cam), 1994-1995, PN 8451**

#### **Parts Included:**

1 - Distributor

1 - O-Ring

1 - Gear Lubricant

**WARNING:** During installation disconnect the battery cables. When disconnecting the battery, always remove negative cable first and install it last.

## **GEAR INFORMATION**

The Pro-Billet PN 8451, PN 8452, PN 8455 and PN 8456 Distributors are designed as a direct replacement for Ford EFI High Output engines and are equipped with a steel gear for the hydraulic roller camshaft.

The PN 8453 model is a replacement for 351W engines with a TFI Ignition module and is supplied with an iron gear (non-roller camshaft).

## **REMOVAL**

1. Remove the existing distributor cap without disconnecting any spark plug wires.
2. With the cap off, turn the engine over until the rotor is aimed at a fixed point on the engine or firewall. Note this position by making a mark (Figure 1).
3. Place the distributor cap back on and note which plug wire the rotor is pointing at. Mark the spark plug wires and remove the cap.
4. Disconnect the connector from the distributor's ignition module.
5. Loosen the distributor hold-down clamp and slide it out of the way.
6. Lift the distributor out of the engine. Note that the rotor rotates as you lift it out. This is due to the helical cut gear and should be taken into consideration when installing the new distributor.

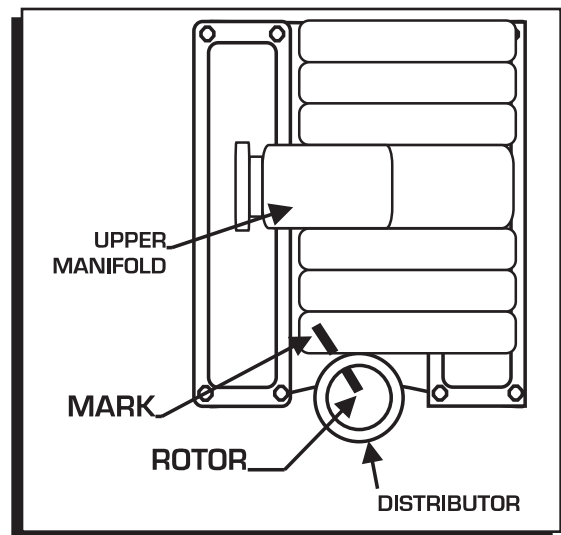

**Figure 1 Marking the Distributor Location.**