



# INSTALLATION INSTRUCTIONS

## MSD Distributor Cap PN 8433 and PN 84333

### Parts Included:

1 - Cap  
2 - 10-32 x 1.25" Hex Screws

1 - Wire Retainer  
2 - 1.5" Phillips Head Screws

**Note:** If you need to adapt your spark plug wire boots and terminals to fit the towers of the PN 8433 Cap, MSD offers a kit of nine boots and terminals, PN 8849.

The PN 8433 Cap fits all of the MSD Distributors that use the GM Socket style cap (MSD PN 8437). It will also fit GM Distributors that use a "window" style cap.

Before installing the new cap, note the location of the spark plug wires. It is a good idea to mark the location of one wire before removing it while leaving the other wires connected to the old cap. Then, with the new cap installed, you can install each wire individually avoiding any confusion.

After installing the spark plug wires, position the retainer over the boots. Align the mounting bosses and use the supplied 1.5" self-tapping Phillips head screws to hold the retainer in place. It may be necessary to apply a slight amount of lubricant to the boots to help them seat into the retainer properly.

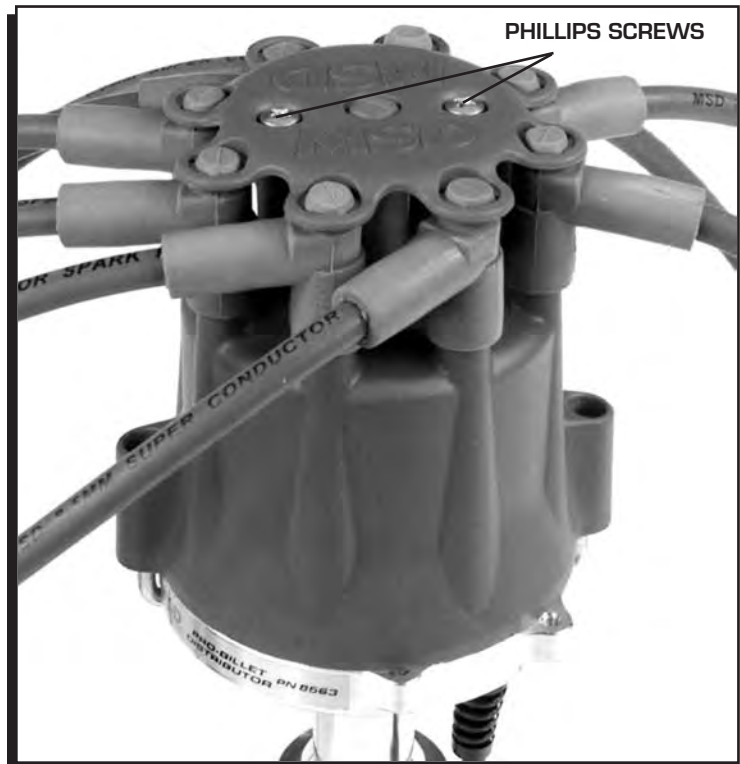

Figure 1 Installing the Wire Retainer.

# MSD<sup>®</sup> IGNITION INSTALLATION INSTRUCTIONS

**Installation Option:** This Cap can also be bolted down to an MSD Pro-Billet or Billet Distributor base with the supplied hardware. To accomplish this, the spring clips must be cut off (Figure 2).

**Note:** When the cap is bolted down, the location of the spark plug wires must be changed.

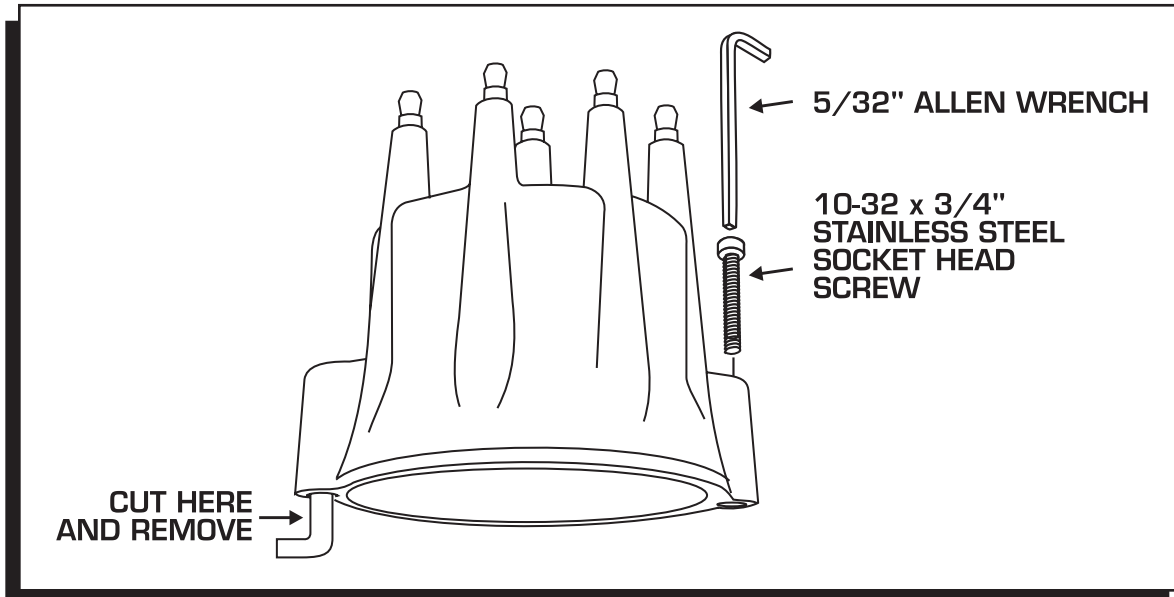

Figure 2 Optional Installation by Bolting the Cap Down.