

MSD[®] IGNITION INSTALLATION INSTRUCTIONS

MSD Rotor, PN 8423 Fits MSD Cap-A-Dapt, PN 8445 and PN 8441 also, MSD Distributors with Cap PN 8408

Parts Included:

1 – Rotor, PN 8423

2 – 5/8" [Phillips Head Screws](#)

2 – 3/4" Phillips Head Screws

2 – Belleville Washers

WARNING: Disconnect the battery during installation. When disconnecting the battery, always remove the negative cable first and install it last.

IMPORTANT: There are two different length screws supplied with this rotor. It is important to determine which screws are correct for your application due to clearance of the magnetic pickup.

Remove the cap, rotor and the cap spacer and note the rotor screw retainer that is installed on the bottom of the advance plate (Figure 1). There are two styles used; one is a Screw Retainer, the other is a Retainer with a Nut. The Retainer accepts the shorter 5/8" screw while the Nut version accepts the 3/4" screw.

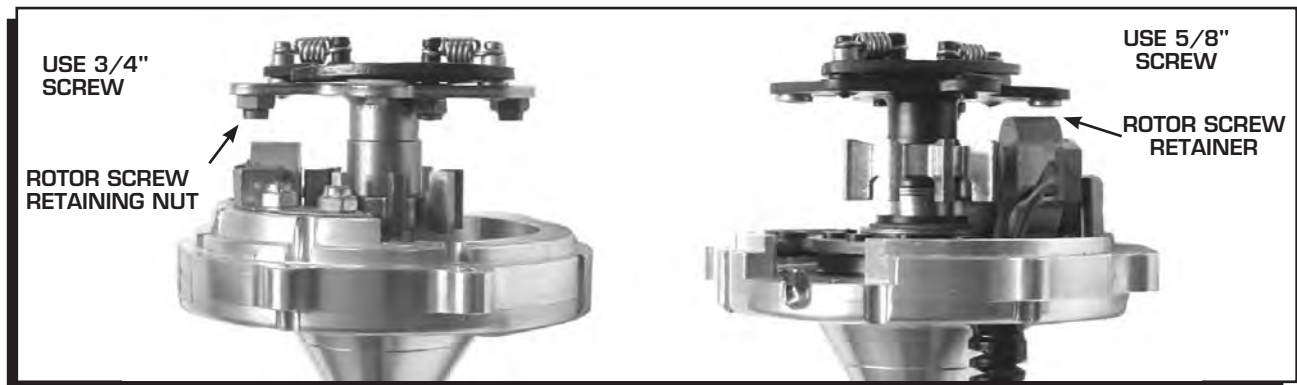

Figure 1 Determining Rotor Screw Length.

Note: It is recommended to install the rotor and check the clearance before reassembling the distributor.

Once the rotor screw length is determined, install the rotor being sure the round and square aligning pegs are lined up correctly. Install the Belleville washers with the **dome facing up** on the screws and tighten the rotor (Figure 2). Install the cap and plug wires.

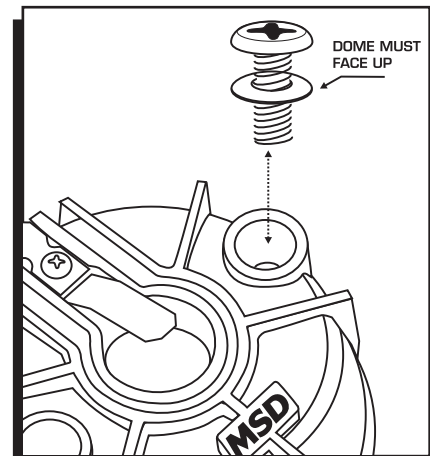

Figure 2 Washer Installation.