

MSD **IGNITION** **INSTALLATION INSTRUCTIONS**

MSD Pro-Billet Digital E-Curve Distributor **PN 8394 - U.S. Patent 6820602**

Important: Read these Instructions before attempting the installation.

Parts Included:

1 - Digital E-Curve Distributor	1 - 3-Pin Harness
1 - Rotor, PN 8467	1 - Gasket
1 - Distributor Cap, PN 8433	1 - Tube of Gear Lubricant
1 - Wire Retainer	2 - O-Rings
2 - 1.5" Self Tapping Screws	1 - Timing Tape Set, PN 8985

WARNING: Before installing the MSD Digital E-Curve Distributor, disconnect the battery cables. When disconnecting the battery cables, always remove the Negative (-) cable first and install it last.

Note: The terminals of this Digital E-Curve Distributor require spark plug style terminals. You may need to change the terminals and boots of your wires. MSD offers two kits, PN 8849 or PN 8848 that are supplied with nine boots and terminals.

Note: If the gear is ever replaced, MSD Gear (PN 8531) is required for replacement due to the .500" diameter shaft.

DIGITAL E-CURVE FUNCTIONS

RPM LIMIT

This distributor is equipped with an adjustable rev limiter. It is adjustable from 5,000 - 10,000 rpm by a rotary dial under the cap and rotor (Figure 1). The rpm will not exceed your selected amount to protect the engine from overrev damage.

TIMING FUNCTIONS

Electronic Advance Curve Operation: The Electronic Advance Curve is managed by a microprocessor built into the ignition module. You can program an electronic timing advance curve by adjusting two rotary switches under the distributor cap (Figure 1). A magnetic pickup is used as a trigger device that tells the ignition module when to fire the coil. The pickup is triggered by a reluctor mounted to the distributor shaft. This means that you have to set the distributor at the highest, or Total, amount of advance that you want to achieve (including vacuum advance) and compensate with one of the selectable ignition curves (shown on page 4). Following are important definitions that will be used to set up your timing.

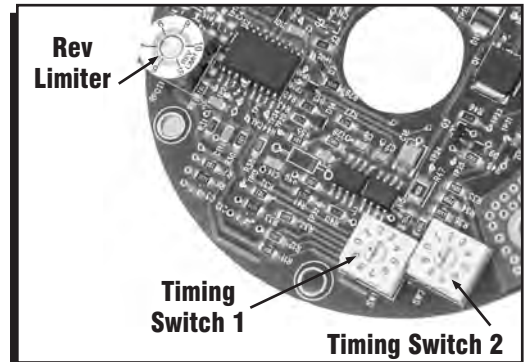

Figure 1 Rotary Dial Adjustments.

Electronic Centrifugal Advance: Since this distributor is all electronic, there really is no mechanical or centrifugal advance. On a standard distributor, this advance would be called centrifugal so it will be referred to as the electronic centrifugal advance. The chart on page 4 shows all of the different combinations you can achieve by simply turning the two rotary dials located under the distributor cap.

Total Timing: This is the total amount of timing that the engine will achieve. This is the amount that all of the electronic curve and settings will be based from. This setting also includes any amount of vacuum advance that you plan to use.

Vacuum Advance: The vacuum advance will advance the timing under part throttle conditions when the engine is not under a heavy load. This advance is added on to the electronic timing curve as well. The advance will begin as low as 4-in. of vacuum and will max out at 10-in. of vacuum. There is a separate chart in Figure 3 that illustrates the vacuum curve selection.

Locked-Out Timing: If you do not want to have a timing advance, set the rotary dials in the Locked-Out position. This means the timing will not move from the setting you position the distributor in. You may however, take advantage of a start retard (see below).

Start Retard: When you select Locked-Out timing, the engine may be hard to crank. A start retard amount can be selected to aid in cranking. This amount can range from 5°, 10°, 15° and 20°. When the engine is cranking, the timing will be retarded. Once the engine reaches 600 rpm, the timing will return to the locked-out setting.

Note: The total amount of any timing change that can be achieved is 34° (25° for the electronic advance with vacuum an additional 9°). This includes the electronic advance as well as the vacuum advance.

Note: It is recommended to have a dial-back timing light, timing tape or a fully degreed balancer to set the timing correctly.

CHOOSING AN ADVANCE CURVE

The function of the advance curve is to match the ignition timing to the burning rate of the fuel with the speed (rpm) of the engine. The piston is traveling much faster through the combustion stroke at 5,000 rpm compared to 1,000 rpm. Any factor that changes the burning rate of the fuel or the engine speed can cause a need for an ignition timing change. Figure 2 shows some of the factors that will affect engine timing.

FACTOR	Advance Timing For	Retard Timing For
Cylinder Pressure	Low	High
Vacuum	High	Low
Energy of Ignition	Low	High
Fuel Octane	High	Low
Mixture (Air/Fuel)	Rich	Lean
Temperature	Cool	Hot
Combustion Chamber Shape	Open	Compact
Spark Plug Location	Offset	Center
Combustion Turbulence	Low	High
Load	Light	Heavy

Figure 2 Ignition Timing Factors.

As you can see from the chart, most factors will change throughout the range of the engine operation. The Digital E-Curve allows you to make timing changes based on these factors.

Example: An engine has 11:1 compression, a high energy ignition and turns 5,500 rpm. With the specifications given, you will have to retard the timing for the high compression and high energy ignition. By comparing the engine's specifications against the chart, a usable timing guideline can be found. Engines with a combination of items from both columns will require a timing that is set in the mid range.

Obviously a full technical explanation of correct ignition timing would be very complicated. The best way to arrive at a suitable ignition curve for your engine is to use the Ignition Timing Factors Chart as a guide and compare it to the Advance Graphs in Figure 3 until a suitable curve is found. When selecting your advance curve, use detonation (engine ping) as an indicator of too much advance, and a decrease in power as an indicator of too little advance. Also consider how the engine cranks and starts. Too much advance can cause an engine to crank slow or even kick back. Here are a couple of suggestions.

- Use as much initial advance as possible without encountering excessive starter load.
- Start the electrical advance just above the idle rpm.
- Select an advance curve that produces good acceleration without detonation.

SETTING UP THE DISTRIBUTOR

Once you have determined your desired total timing, you'll need to select the electronic advance curve that you want to run (Review the information on page 2 to help choose a curve that matches your needs). The charts in Figure 3 show all of the different timing curves available. Note that a letter is given to the curve. Refer to the chart in Figure 4 using this letter to determine the position of the two rotary dials. If you plan to take advantage of a vacuum advance, select the vacuum curve number and cross reference it with the mechanical curve's key letter to get the switch positions.

For example: If you want a 20° curve that advances slowly, select curve E. This means you would put Rotary Switch 1 in position "0" and Switch 2 in position "5". If you choose no vacuum advance, simply do not connect the vacuum port. In this example, if you would prefer 10° of vacuum advance, choose Vacuum Curve 3 and cross reference it to Timing Curve E. The switch positions would be Switch 1 "4" and Switch 2 in "5".

To ease installation, use an average timing setting to get the engine started. Set the rotary dials of the E-Curve to zero so there is no timing curve. Position the balancer of the engine between 12° - 18° of Before Top Dead Center on the number one cylinder's combustion stroke. This acts as an average timing setting that will allow the engine to fire up to confirm the wiring is correct. Once started, you can position the distributor to the desired total timing and select a timing curve to program an electronic curve using the rotary dials.

ELECTRONIC 'CENTRIFUGAL' ADVANCE CURVES

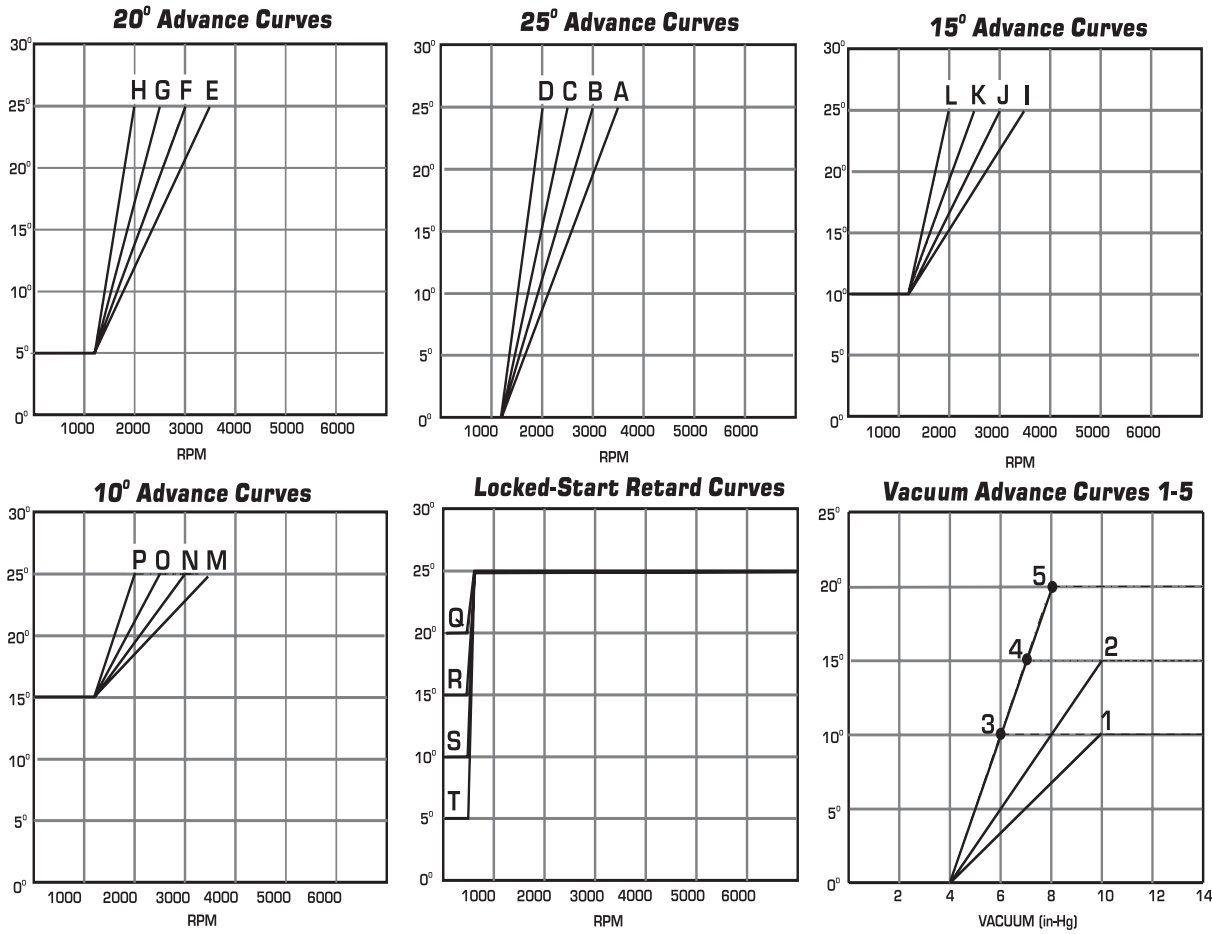

Figure 3 Available Timing Curves.

ELECTRONIC 'MECHANICAL' ADVANCE CURVE

		A	B	C	D	E	F	G	H	I	J	K	L	M	N	O	P	Q	R	S	T	
VACUUM ADVANCE	Switch	1 2	1 2	1 2	1 2	1 2	1 2	1 2	1 2	1 2	1 2	1 2	1 2	1 2	1 2	1 2	1 2	1 2	1 2	1 2	1 2	1 2
	1	0 1	0 2	0 3	0 4	0 5	0 6	0 7	0 8	0 9	1 0	1 1	1 2	1 3	1 4	1 5	1 6	1 7	1 8	1 9	2 0	
	2	2 1	2 2	2 3	2 4	2 5	2 6	2 7	2 8	2 9	3 0	3 1	3 2	3 3	3 4	3 5	3 6	3 7	3 8	3 9	4 0	
	3	4 1	4 2	4 3	4 4	4 5	4 6	4 7	4 8	4 9	5 0	5 1	5 2	5 3	5 4	5 5	5 6	5 7	5 8	5 9	6 0	
	4	6 1	6 2	6 3	6 4	6 5	6 6	6 7	6 8	6 9	7 0	7 1	7 2	7 3	7 4	7 5	7 6	7 7	7 8	7 9	8 0	
	5	8 1	8 2	8 3	8 4	8 5	8 6	8 7	8 8	8 9	9 0	9 1	9 2	9 3	9 4	9 5	9 6	9 7	9 8	9 9	0 0	

Figure 4 Advance Curve Switch Position.

INSTALLING THE DISTRIBUTOR

Note: When installing the distributor for the first time, it is recommended to place the switches in the locked-out timing position. This will assist you in setting the timing curve by ensuring that the total timing is correct.

1. Remove the existing distributor cap without disconnecting any of the spark plug wires.

2. With the cap off, crank the engine until the rotor is aimed at a fixed point on the engine or firewall. Note this position by making a mark (Figure 5).

3. Place the distributor cap back on and note which plug wire the rotor is pointing to. **MARK THE SPARK PLUG WIRES** and remove the distributor cap.

4. Disconnect the wiring from the distributor.

5. Loosen the distributor hold down clamp and slide the clamp out of the way.

6. Lift the distributor out of the engine. Note that the rotor rotates as you lift the distributor out. This is due to the helical cut gear and should be taken into consideration when installing the new distributor.

7. Install the gasket and apply a liberal amount of the supplied lubricant to the distributor gear. (The supplied O-rings can **only** be used if the block has been modified as shown in Figure 6.)

8. Install the distributor making sure that the rotor comes to rest pointing at the fixed mark. If the distributor will not fully seat with the rotor pointing to the marked position, you may need to rotate the oil pump shaft until the rotor lines up and the distributor fully seats.

9. Position and tighten the hold down clamp onto the distributor.

10. Install the distributor cap and spark plug wires one at a time to ensure correct location. A wire retainer is supplied to secure the wires in place. Align the mounting bosses and use the supplied 1.5" self-tapping Phillips screws to hold the retainer in place.

11. Proceed to wiring the distributor as shown in Figures 7 and 8. Review the starting and tuning tips information and install the Timing Tape as shown on page 7 before starting the engine.

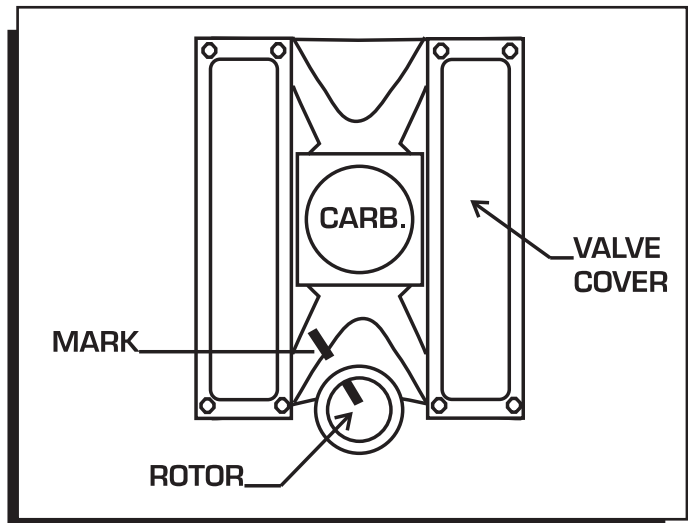

Figure 5 Marking the Rotor Location.

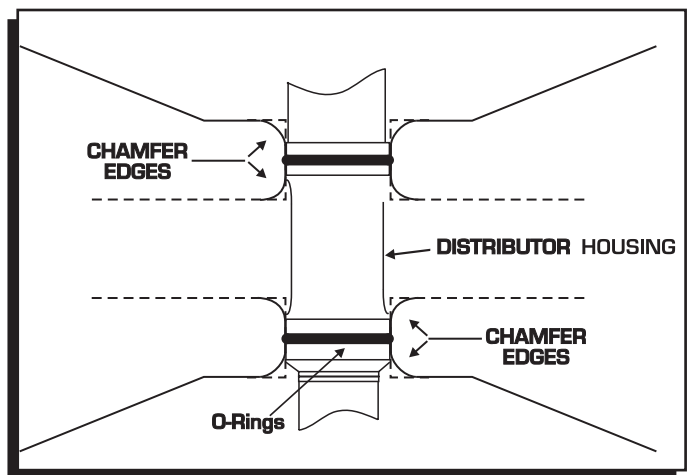

Figure 6 Modified Block for use with O-Rings.

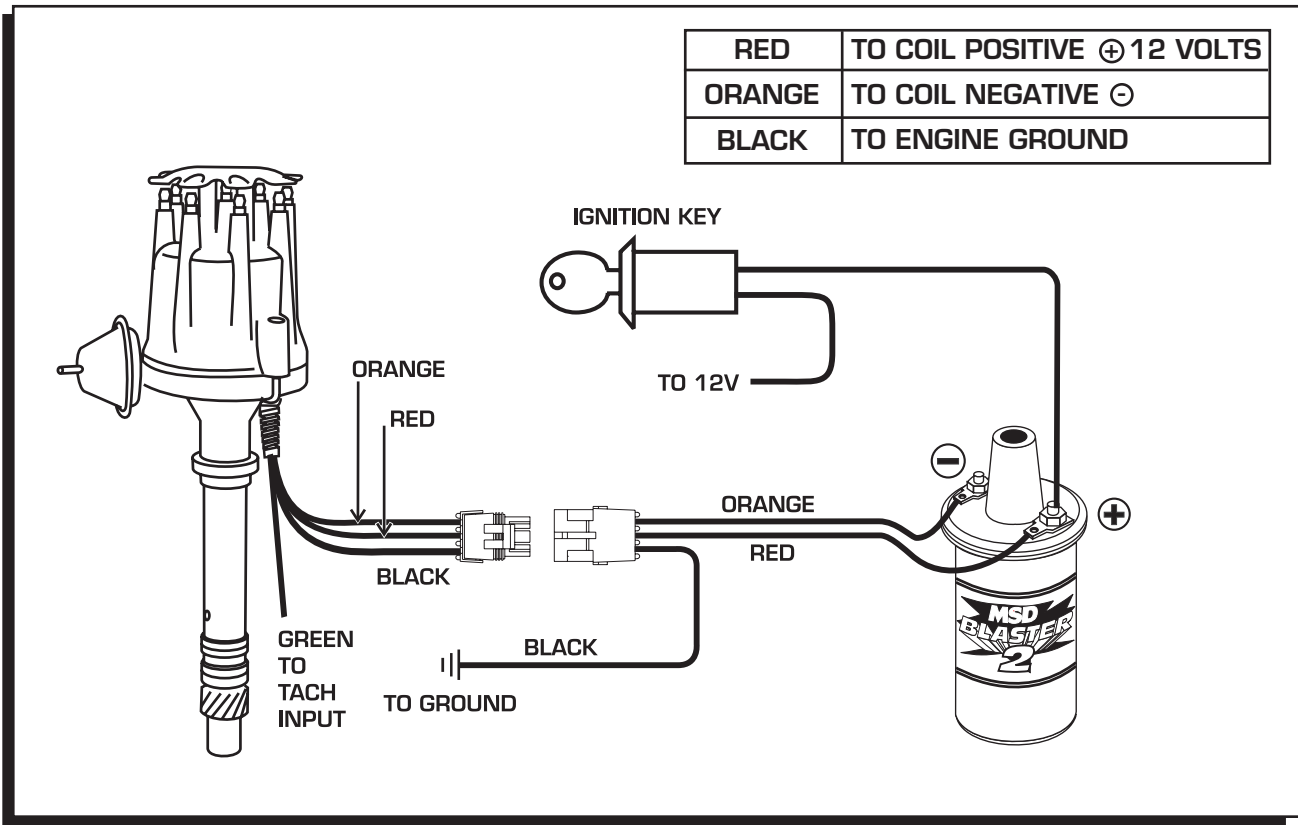

Figure 7 Wiring the Ready-to-Run Chevrolet Distributor.

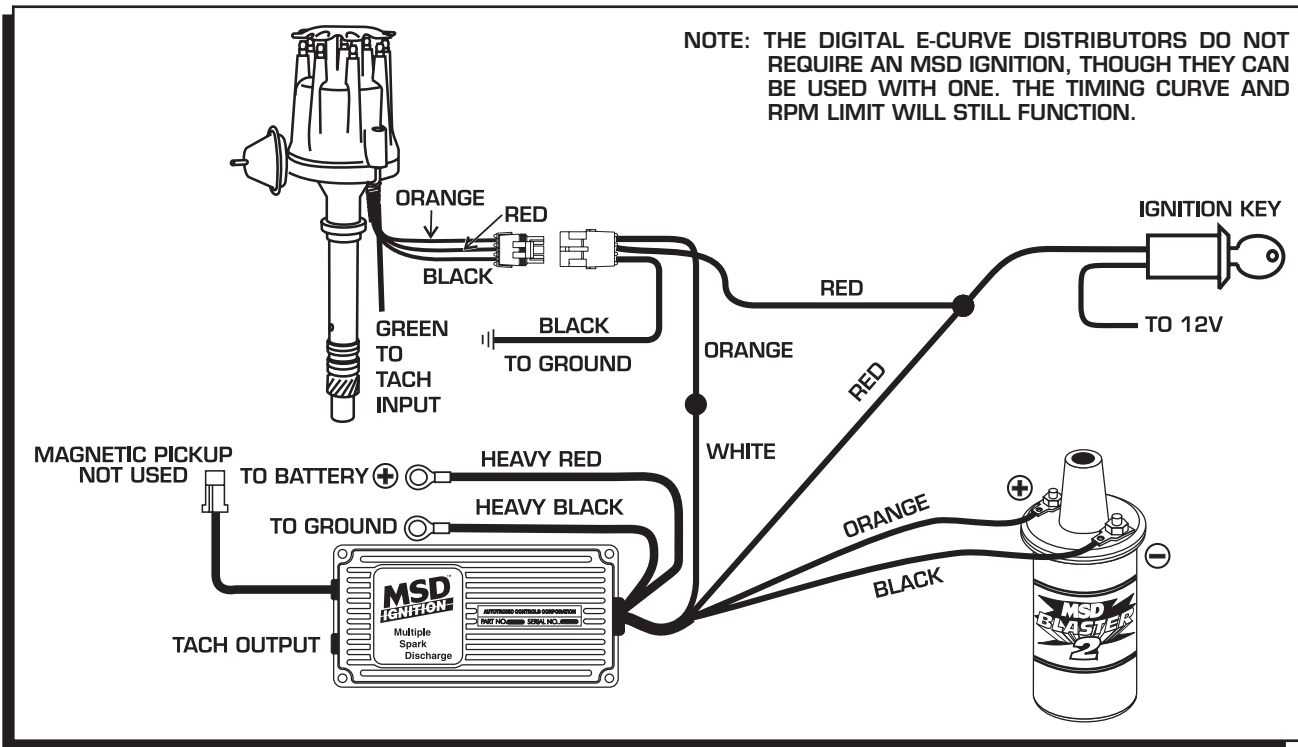

Figure 8 Connecting an MSD Ignition Control to the Digital E-Curve Distributor.

INSTALLING THE TIMING TAPE

1. Locate the top-dead center or 0° mark on the harmonic balancer or timing wheel.
2. Select the correct timing tape for your application. Make sure you know the correct size of the harmonic balancer or timing wheel you're using. If this is not known, measure the diameter of the harmonic balancer or timing wheel's edge and note the size.
3. Choose the timing tape that matches your balancer's diameter. Be sure that the mating surface is clean of any dirt, grease or debris. Locate and note the 0° mark on the timing tape.
4. Align the 0° mark on the tape with the TDC mark on the balancer. Make sure that the markings on the tape are facing you, and place the tape on the surface. Use firm pressure for proper adhesion. ATC (after top-dead center) will be to the left of the stock mark, and BTC (before top-dead center) will always be to the right of the stock mark.



Figure 9 The Timing Tape Installed.

STARTING AND TUNING TIPS

- Position the rev limiter rotary dial at your desired rpm limit.
- At this point, the distributor should be installed at your desired timing and wired to the coil, and ground.
- It is recommended that you have a dial-back timing light or degreed balancer. MSD offers a timing tape that you can apply to your balancer as PN 8985.
- Select a Locked-Out with Start Retard to start the engine (These are Curves Q, R, S or T). This way you can position the distributor to obtain your ideal total timing before selecting a timing curve.
- If you are going to use a vacuum advance curve, use a 3/16" vacuum line connected to ported vacuum. This means a vacuum source that is above the throttle plates. Also, remember to disconnect and plug the vacuum line when setting the timing curve.

MSD IGNITION INSTALLATION INSTRUCTIONS

Installation Option: This Cap can also be bolted down to an MSD Pro-Billet or Billet Distributor base with the supplied hardware. To accomplish this, the spring clips must be cut off (Figure 10).

Note: When the cap is bolted down, the location of the spark plug wires must be changed.

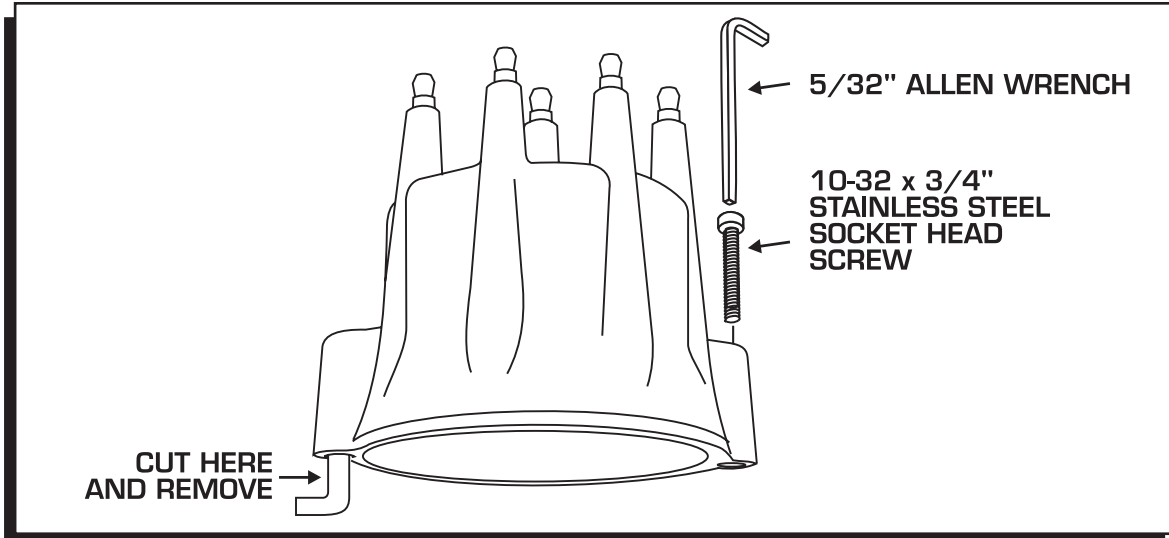

Figure 10 Optional Installation by Bolting the Cap Down.