

INSTALLATION INSTRUCTIONS

MSD Pro-Billet Chrysler Distributor PN 83891 - 392 Early Hemi

Parts Included:

| | |
|-------------------------------------|---------------------------------|
| 1 - Pro-Billet Distributor | |
| 1 - Rotor, PN 8467 | 1 - Advance Kit |
| 1 - Distributor Cap, PN 8433 | 1 - O-Ring |
| 1 - Wire Retainer | 1 - Vacuum Advance Lock-Out Kit |
| 2 - 1.5" Self Tapping Screws | |
| 2 - 10-32 x 3/4" Socket Head Screws | |

WARNING: Before installing the MSD Distributor, disconnect the battery cables. When disconnecting the battery cables, always remove the Negative (-) cable first and install it last.

Note: The terminals of this Distributor require spark plug style terminals. You may need to change the terminals and boots of your wires. MSD offers two kits, PN 8849 or PN 8848 that are supplied with nine boots and terminals.

TIMING FUNCTIONS

Before continuing with the installation, here are a few definitions you should be aware of:

Initial Timing: This is the base timing (also referred to as idle timing) of the engine before the centrifugal advance begins.

Centrifugal Advance: The centrifugal (or mechanical) advance mechanism is made up of weights, springs, advance cams, and an advance stop bushing. The amount and rate of advance that your distributor is capable of is determined by the centrifugal timing. If you ever wish to lock out the centrifugal advance, refer to the centrifugal advance section.

Total Timing: This is the total of the initial timing plus the centrifugal advance added together. Example: 10° Initial + 25° centrifugal = 35° Total Timing. (When checking Total timing, disconnect and cap the vacuum canister and plug the vacuum line.)

Vacuum Advance: The vacuum advance will advance the timing up to approximately 12° during partial throttle driving (with 15 lbs of vacuum). The vacuum line should be routed to a ported vacuum outlet above the throttle plates.

Note: MSD Distributors are supplied with the heavy (slow) advance springs and the 21° stop bushing installed. This is to prevent detonation in certain applications. Review the information on pages 2-4 to determine the best advance curve for your application.

CHOOSING AN ADVANCE CURVE

The function of the advance curve is to match the ignition timing to the burning rate of the fuel and speed (rpm) of the engine. Any factor that changes the burning rate of the fuel or the engine speed can cause a need for an ignition timing change. Figure 1 shows some of the factors that will affect engine timing.

| FACTOR | Advance Timing | Retard Timing |
|--------------------------|----------------|---------------|
| | For | For |
| Cylinder Pressure | Low | High |
| Vacuum | High | Low |
| Energy of Ignition | Low | High |
| Fuel Octane | High | Low |
| Mixture (Air/Fuel) | Rich | Lean |
| Temperature | Cool | Hot |
| Combustion Chamber Shape | Open | Compact |
| Spark Plug Location | Offset | Center |
| Combustion Turbulence | Low | High |
| Load | Light | Heavy |

Figure 1 Ignition Timing Factors.

As you can see from the chart, most factors will change throughout the range of the engine operation. The timing mechanism of the distributor must make timing changes based on these factors.

Example: An engine has 11:1 compression with a high energy ignition. With the specifications given, you will have to retard the timing for the high compression and high energy ignition. By comparing the engine's specifications against the chart, a usable timing guideline can be found. Engines with a combination of items from both columns will require a timing that is set in the mid range.

Obviously a full technical explanation of correct ignition timing would be very complicated. The best way to arrive at a suitable ignition curve for your engine is to use the Ignition Timing Factors Chart as a guide and compare it to the Advance Graphs in Figure 4 until a suitable curve is found. When selecting your advance curve, use detonation (engine ping) as an indicator of too much advance, and a decrease in power as an indicator of too little advance.

TIPS ON SELECTING AN ADVANCE CURVE

- Use as much initial advance as possible without encountering excessive starter load.
- Start the centrifugal advance just above the idle rpm.
- The starting point of the centrifugal advance curve is controlled by the installed length and tension of the spring.
- How quickly the centrifugal advance (slope) comes in is controlled by the spring stiffness. The stiffer the spring, the slower the advance curve.
- The amount of advance is controlled by the advance bushing. The bigger the bushing, the smaller the amount of advance.

CENTRIFUGAL ADVANCE CURVE

SELECTING THE ADVANCE SPRINGS

The rate, or how quick the advance comes in is determined by the type of springs which are installed on the distributor. The MSD distributors are equipped with two Heavy Silver springs installed. These will give you the slowest advance curve possible (Figure 2). The parts kit contains two additional sets of springs which can be used to match the advance curve to your particular application. Refer to the Spring Combination Chart (Figure 3) for combinations that can be achieved.

To change the springs, remove the cap and rotor and use needlenose pliers to remove the springs. Be sure the new springs seat in the groove on the pin.

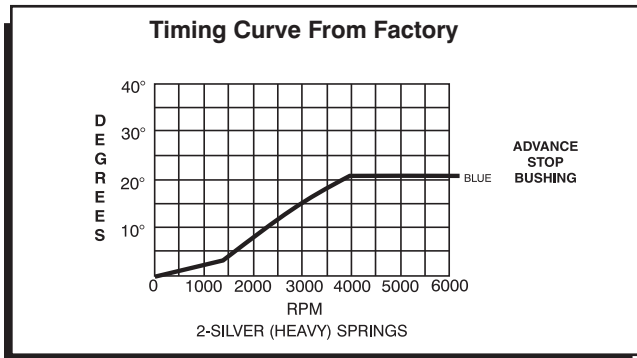

Figure 2 The Factory Equipped Curve.

| SPRING COMBINATION | RATE OF ADVANCE | FIGURE 4 |
|--------------------|-----------------|----------|
| 2- Heavy Silver | | A |
| 1- Heavy Silver | | B |
| 1- Light Blue | | C |
| 1-Heavy Silver | | D |
| 1-Light Silver | | E |
| 2- Light Blue | | F |
| 1- Light Silver | FASTEST | |
| 1- Light Blue | | |
| 2- Light Silver | | |

Figure 3 Spring Combination Chart.

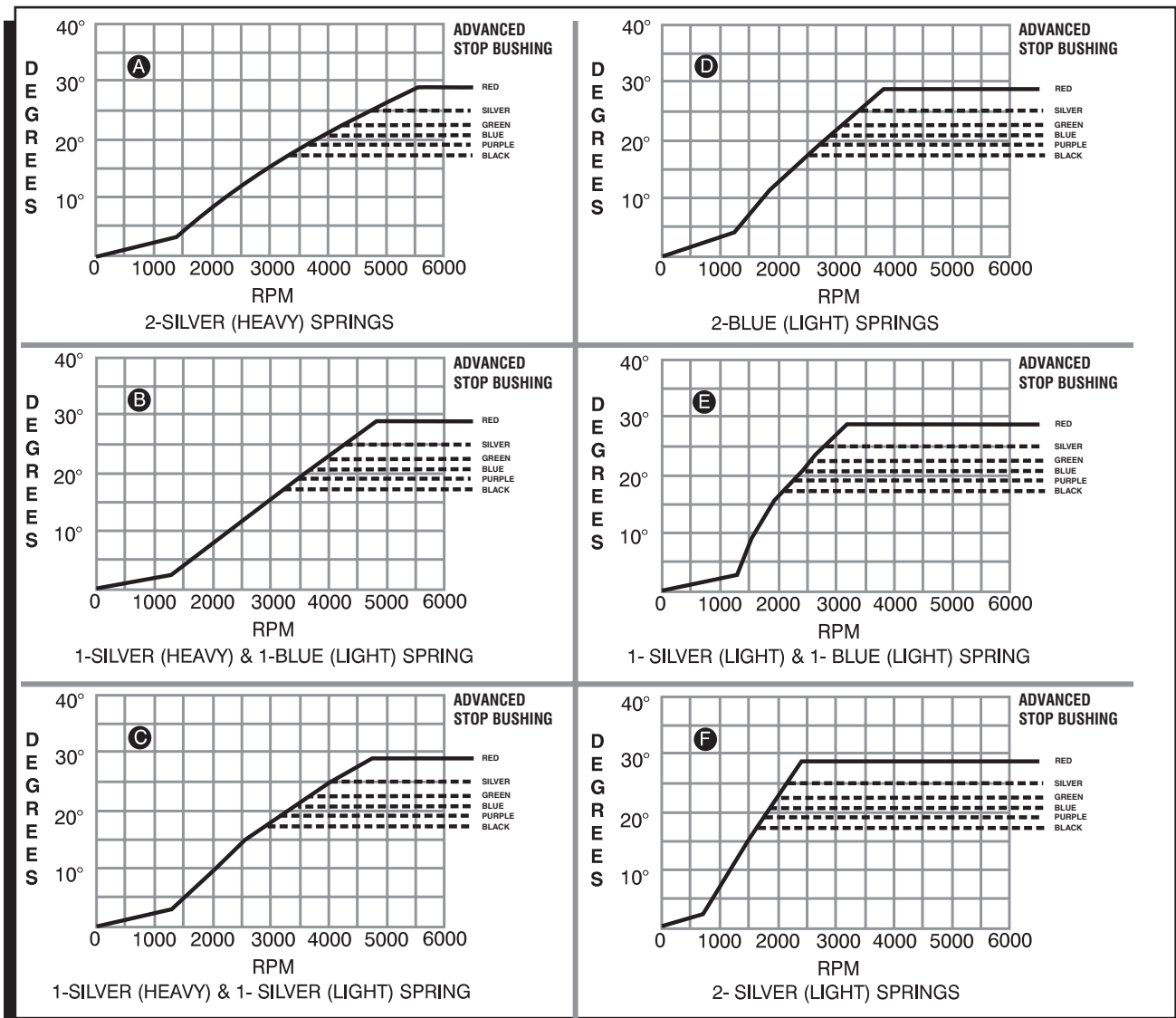

Figure 4 Advance Curves.

SELECTING THE ADVANCE STOP BUSHING

Five different advance stop bushings are supplied in the distributor kit. The distributor comes with a Blue (21°) bushing already installed. If a different amount of centrifugal advance is desired, follow the next procedure to change the bushings. The chart in Figure 5 gives the size and approximate degrees for the corresponding bushings.

CHANGING THE ADVANCE STOP BUSHINGS

1. Remove the distributor cap and rotor.
2. Remove the locknut and washer on the bottom of the advance assembly (Figure 6).
3. Remove the bushing and install the new one. Install the washer and locknut.

LOCKING OUT THE CENTRIFUGAL ADVANCE

1. Remove the advance components including the springs, weights and the advance stop bushing from the advance assembly.
2. Remove the roll-pin from the shaft and slide the retaining sleeve down, (Figure 7).
3. Slide the shaft two inches out of the housing.
4. Rotate the shaft 180° and insert the advance stop bushing pin into the small hole on the advance plate (Figure 8).
5. Install the locknut and washer to the advance stop bushing pin. This locks the advance in place.
6. Install the retaining sleeve and roll-pin.

Note: If you want to lock out the vacuum advance, see page 6.

| BUSHING SIZE | APPROXIMATE CRANKSHAFT DEGREES |
|---------------|--------------------------------|
| Red-Smallest | 28 |
| Silver | 25 |
| Green | 23 |
| Blue | 21 |
| Purple | 19 |
| Black-Largest | 18 |

Figure 5 Advance Stop Bushing Chart.

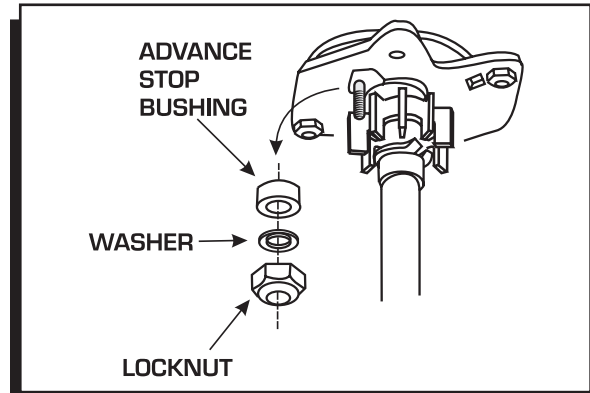

Figure 6 Changing the Advance Stop Bushing.

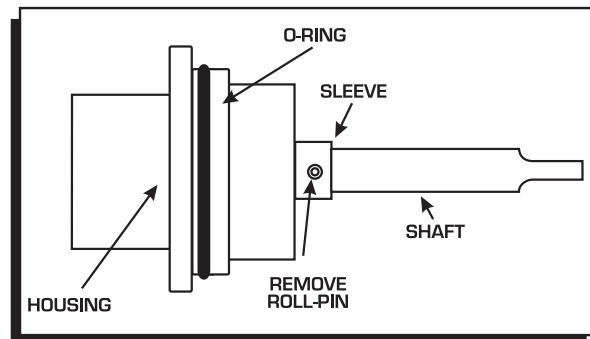

Figure 7 Removing the Retaining Sleeve.

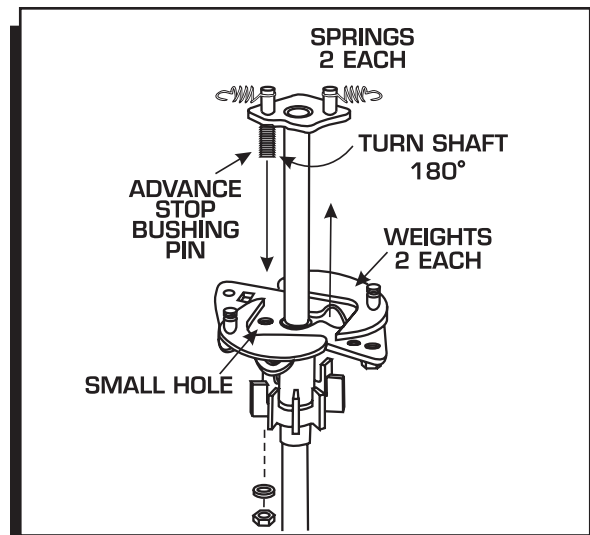

Figure 8 Locking Out the Advance.

INSTALLING THE DISTRIBUTOR

1. Remove the existing distributor cap without disconnecting any of the spark plug wires.
2. With the cap off, crank the engine until the rotor is aimed at a fixed point on the engine or firewall. Note this position by making a mark (Figure 9).
3. Place the distributor cap back on and note which plug wire the rotor is pointing to. **MARK THE SPARK PLUG WIRES** and remove the distributor cap.
4. Disconnect the wiring from the distributor.
5. Loosen the distributor hold down clamp, slide the clamp out of the way and lift the distributor out of the engine.
6. Install the new O-ring and install the new distributor making sure that the rotor comes to rest pointing at the fixed mark. If the distributor will not fully seat with the rotor pointing to the marked position, you may need to rotate the oil pump shaft until the rotor lines up and the distributor fully seats.
7. Position and tighten the hold down clamp onto the distributor.
8. Install the distributor cap and spark plug wires one at a time to ensure correct location. An optional wire retainer is supplied to secure the wires in place. Align the mounting bosses and use the supplied 1.5" self-tapping Phillips screws to hold the retainer in place.

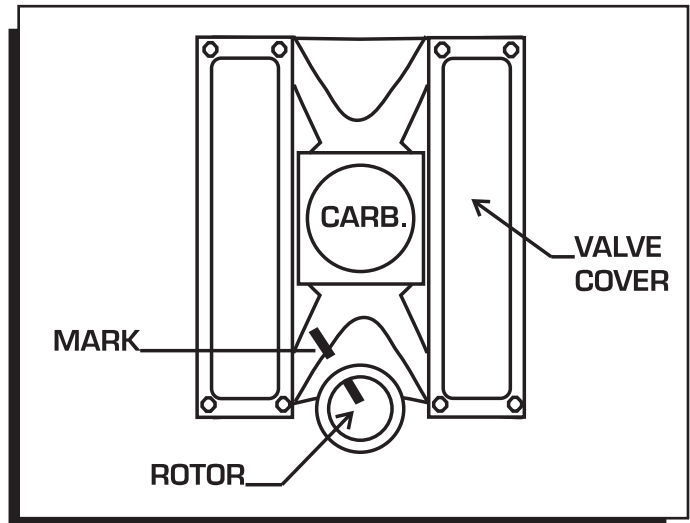

Figure 9 Marking the Rotor Location.

Installation Option: This Cap can also be bolted down to an MSD Pro-Billet or Billet Distributor base with the supplied hardware. To accomplish this, the spring clips must be cut off (Figure 10).

Note: When the cap is bolted down, the location of the spark plug wires must be changed.

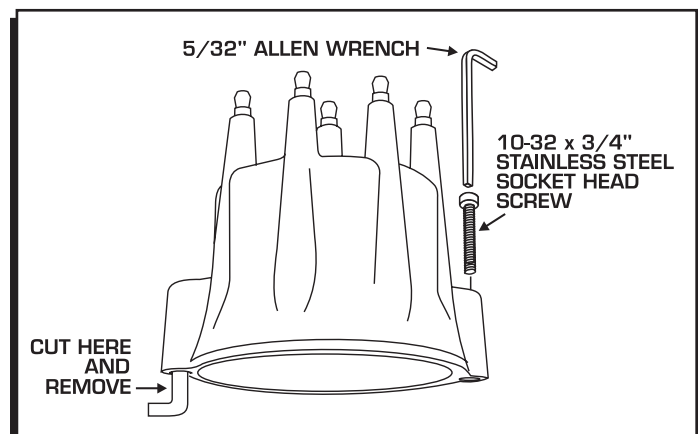

Figure 10 Optional Installation by Bolting Cap Down.

VACUUM ADVANCE

Your distributor is equipped with an optional vacuum advance canister. Vacuum advance is generally used to improve cruising economy and driveability, depending on the application.

The chart in Figure 11 shows the relationship between engine vacuum and the amount of ignition timing advance.

To connect the vacuum advance, connect a vacuum hose from the canister to a ported vacuum source on the carburetor or throttle body. Ported vacuum sources are located above the throttle plates so there will not be an excessive amount of timing advance at idle and lower engine speeds.

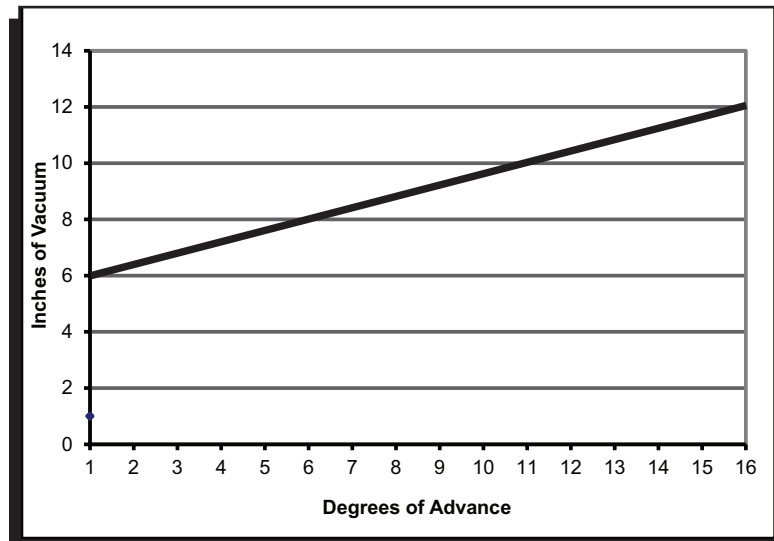

Figure 11 Vacuum Advance and Timing Chart.

VACUUM ADVANCE LOCKOUT

If you do not want to use the vacuum advance canister, MSD has supplied a lockout mechanism.

1. Remove the two Allen head screws that hold the advance canister (Figure 12).
2. Remove the snap ring that holds the magnetic pickup assembly in place.
3. Gently lift up on the mag pickup plate and slide the vacuum canister out.
4. Install the Lockout Plate in place of the canister. Install the two retaining screws.
5. Install the supplied screw and washer through the Lockout and tighten.
6. It is important to make sure the pickup plate is parallel with the housing of the distributor (Figure 13). If it is cocked or slanted, the paddles of the reluctor may contact the pickup. Check the clearance by rotating the distributor shaft. If necessary, use the supplied shims under the Lockout hold-down to correctly position the pickup plate.

Note: If no shims were required, use one beneath the washer of the Lock-Out Hold Down Screw.

Note: Do not forget to plug the original vacuum advance hose.

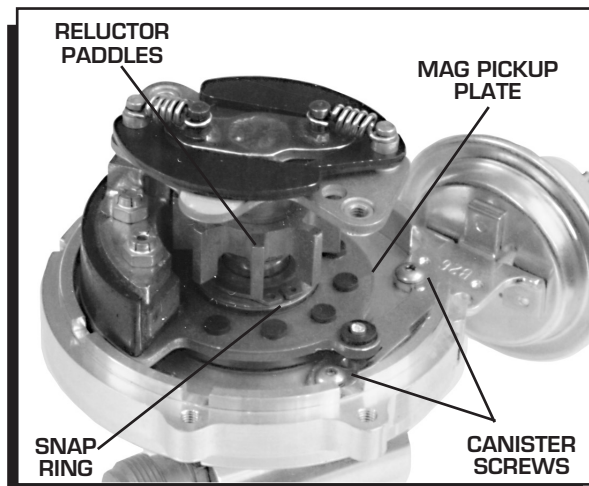

Figure 12 Removing the Vacuum Canister.

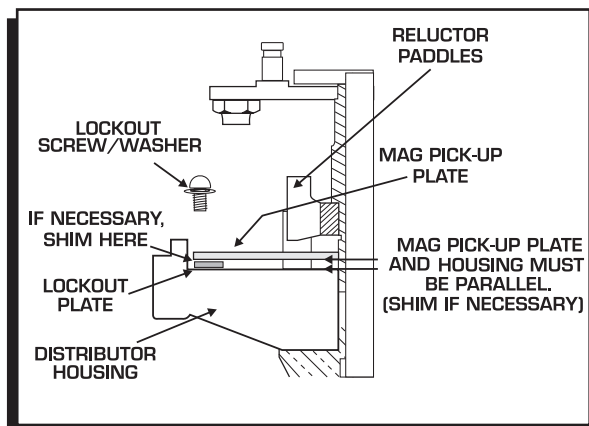

Figure 13 Checking Installation of the Lockout Plate.

WARNING: High voltage is present on the coil terminals. Do not touch the terminals or coil tower when the engine is cranking or running.

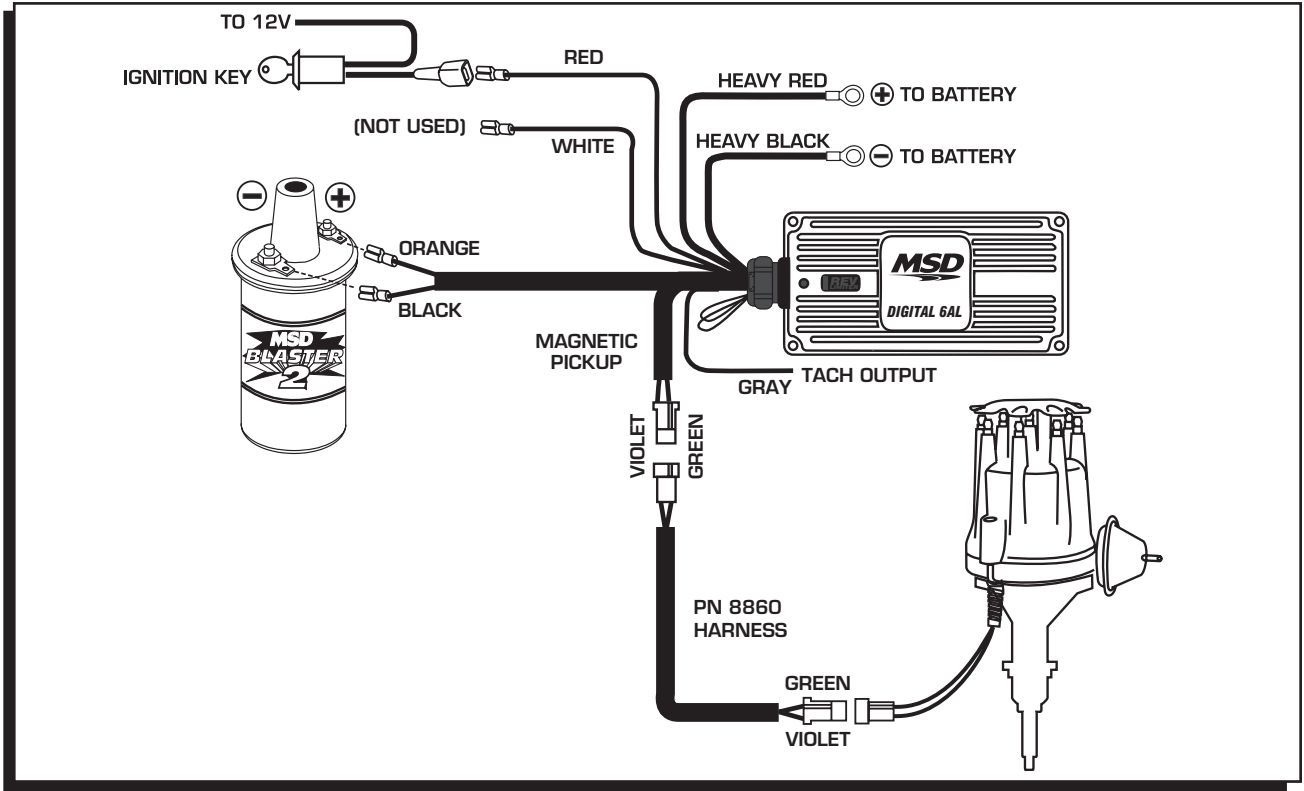

Figure 14 Wiring to an MSD 6-Series Ignition Control.

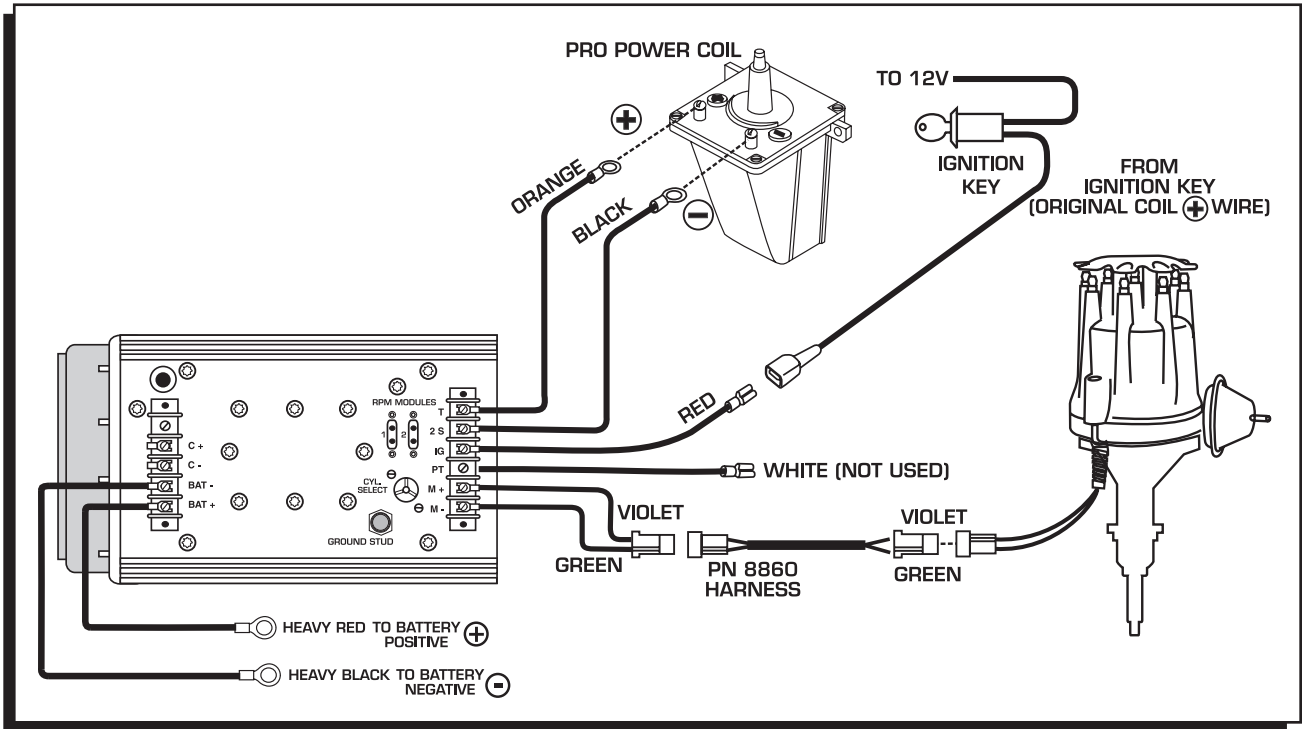

Figure 15 Wiring to an MSD 7-Series Ignition Control.