

MSD INSTALLATION INSTRUCTIONS

MSD 44 Amp Pro Mag Generator Clockwise Rotation - PN 8130, PN 81303, PN 81305 Counterclockwise Rotation - PN 8140, PN 81403, PN 81405

Parts Included In This Kit:

- 1 - 44 Amp Pro Mag Generator
- 1 - Timing Tape, PN 8126

MSD Pro Mag Information

Congratulations on selecting the MSD Pro Mag – the most powerful and reliable magneto available! The following information will answer some of the questions you may come across concerning the Pro Mag.

INITIAL TIMING SETUP

A traditional “Buzz Box” cannot be used to set the timing of a Pro Mag because there are no mechanical points. The Pro Mag incorporates a high output magnetic pickup that ensures accurate timing and never requires adjustment. Follow these steps to

set timing:

1. Position the crankshaft to your desired timing.
2. Position the generator in the engine with the rotor tip leading into the #1 terminal of the cap (Figure 1).
3. Start the engine and verify the timing with a quality timing light such as MSD’s PN 8992 or PN 8991. and adjust timing as needed.

CONVENTIONAL TIMING VS. THE PRO MAG

When converting from a “conventional” (non-MSD) magneto to a Pro Mag, it may be necessary to review your tune up. It is common for the ignition timing to accept a few degrees of retard or an increase in fuel to prevent lean mixtures. Taking the time to test and tune with small incremental changes will prove very beneficial.

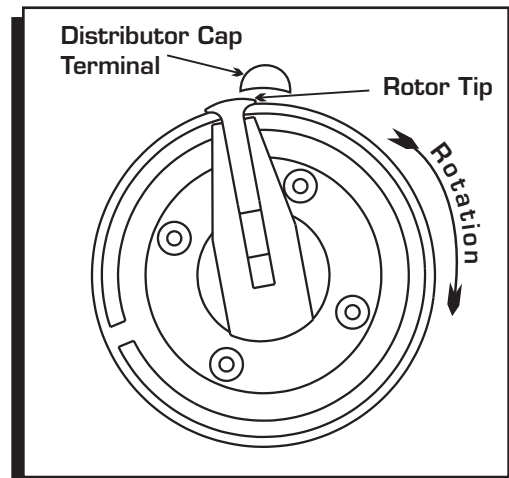

Figure 1 Rotor Tip and Cap Alignment.

CAP AND ROTOR MAINTENANCE

Due to the spark energy that MSD Pro Mags produce it is recommended to inspect the cap, rotor and spark plug wires at closer intervals. The components that are supplied with the Pro Mags are designed for strength and reliability but still require maintenance. Visually inspect for excessive wear or carbon tracking. Cap and Rotors are available as a kit from your MSD Dealer:

Generator

Standard Chevy Generator, Pro Mag 12LT (4" cap) _____
Band Clamp Generators (4" cap)
(12, 20 and 44 Amp Versions) _____

Cap and Rotor Kit

PN 7919 (Red) PN 79193 (Black)
PN 8119

Pro-Cap: 5" Cap - PN 7408 (red) or PN 74083 (black), Rotor - PN 7423, Base - PN 7456 (red) or PN 74563 (black) and Rotor Terminal - PN 7411.

CAP-A-DAPTS

When space permits, upgrading to a larger diameter magneto cap can add extra protection against spark scatter and crossfire. MSD offers a Cap-A-Dapt for each style Pro Mag. Each kit is supplied with everything required to install the new, large cap and rotor assembly.

Pro-Cap, PN 7455 (5" cap)

The largest cap and rotor available plus the entire assembly is molded from strong Rynite material. Designed for MSD generators with a four inch diameter (Figure 2).

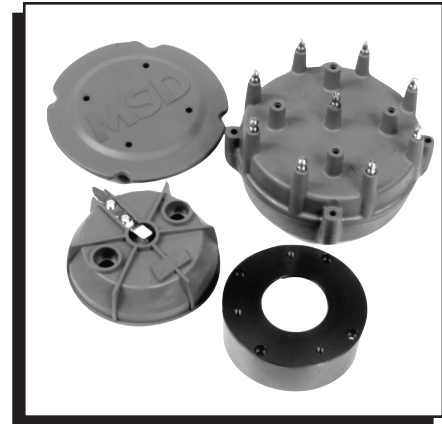

Figure 2 Pro-Cap for Pro Mags, PN 7455.

SPARK PLUG WIRES

MSD only recommends using our 8.5mm Super Conductor spark plug wire. This wire features a copper-alloy conductor with a low resistance of 40 - 50 ohms per foot. The core and winding of the conductor produce a highly effective Electro Magnetic Interference (EMI) choke so it also has extremely high EMI suppression capabilities.

Your spark plug wires should be inspected for cuts, abrasions, resistance and continuity. It should be noted that spark plug wire is a maintenance item of the ignition system and should be replaced at least three times per season. Note that the coil wire should be replaced more frequently than the entire wire set due to handling eight times the energy.

To ensure a quality crimp when building spark plug wire sets, use the MSD Pro Crimp Tool, PN 35051. This Crimp Tool is supplied with the correct crimp dies for the 8.5mm Wire with MSD Dual Crimp Terminals. The dies are also replaceable, PN 3508.

CROSS DRIVES

Band Clamp style Pro Mag generators are equipped with cross drives due to their strength but existing two and four pin drives will interchange.

CRANKING RPM

MSD Pro Mags require a minimum generator speed of 200-250 RPM to start (at the crank). If a block mounted starter is used a 16 volt battery will be required to produce reliable starting rpm. Blower Pulley starters may require 48 volts on Alcohol applications due to pulley drive ratios. On these applications, a jumper wire should be connected across the coil terminals. Once the engine reaches the required RPM this jumper should be pulled quickly from the terminals. MSD offers High Speed Block mounted starters for various applications.

DynaForce High Speed Starters:

Ford 289, 302, 351W - **PN 50902**

Ford BB 351M, 400, 429 - **PN 50922**

Chevy 10 Pitch/139 Tooth - **PN 50953**

Chevy 153/168 Tooth, Pro Mag - **PN 50952**

(Perfect for applications with magnetos that require 250+ rpm to start.)

Chevy 318 - 440 - **PN 50982**

KILL SWITCHES

12 and 20 Amp Pro Mags

Kill switches are supplied with the Electronic Points boxes for the 12 and 20 Amp Pro Mags. Each Point Box requires a Kill Switch. Never use one kill switch for two Points boxes. This MSD Switch, PN 8111, is the only Kill Switch recommended for use with the Pro Mag.

MSD 44 Amp Pro Mags

MSD 44 Amp Pro Mags cannot be used with a common mechanical On/Off switch. A Kill Switch is available through MSD, PN 8134. Jumper wires across the coil terminals are required when starting the engine (Figure 3).

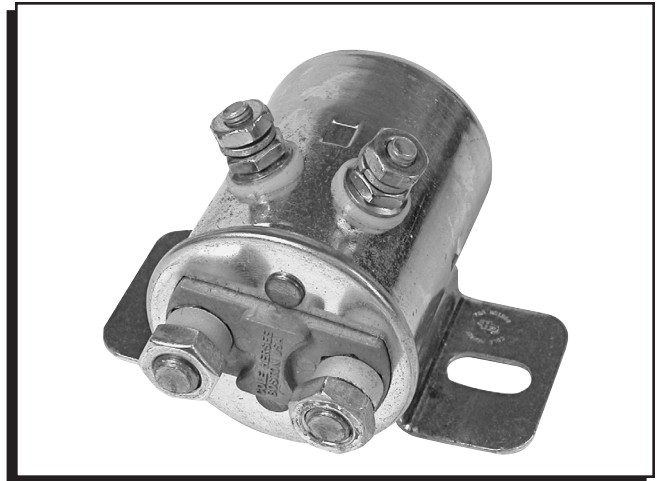

Figure 3 44 Amp Kill Switch, PN 8134

WARNING: Extremely high current and voltage is present on the Pro Mag Coil terminals and on the Kill Switch Relay. Use extreme caution when working around the Coil and Relay.

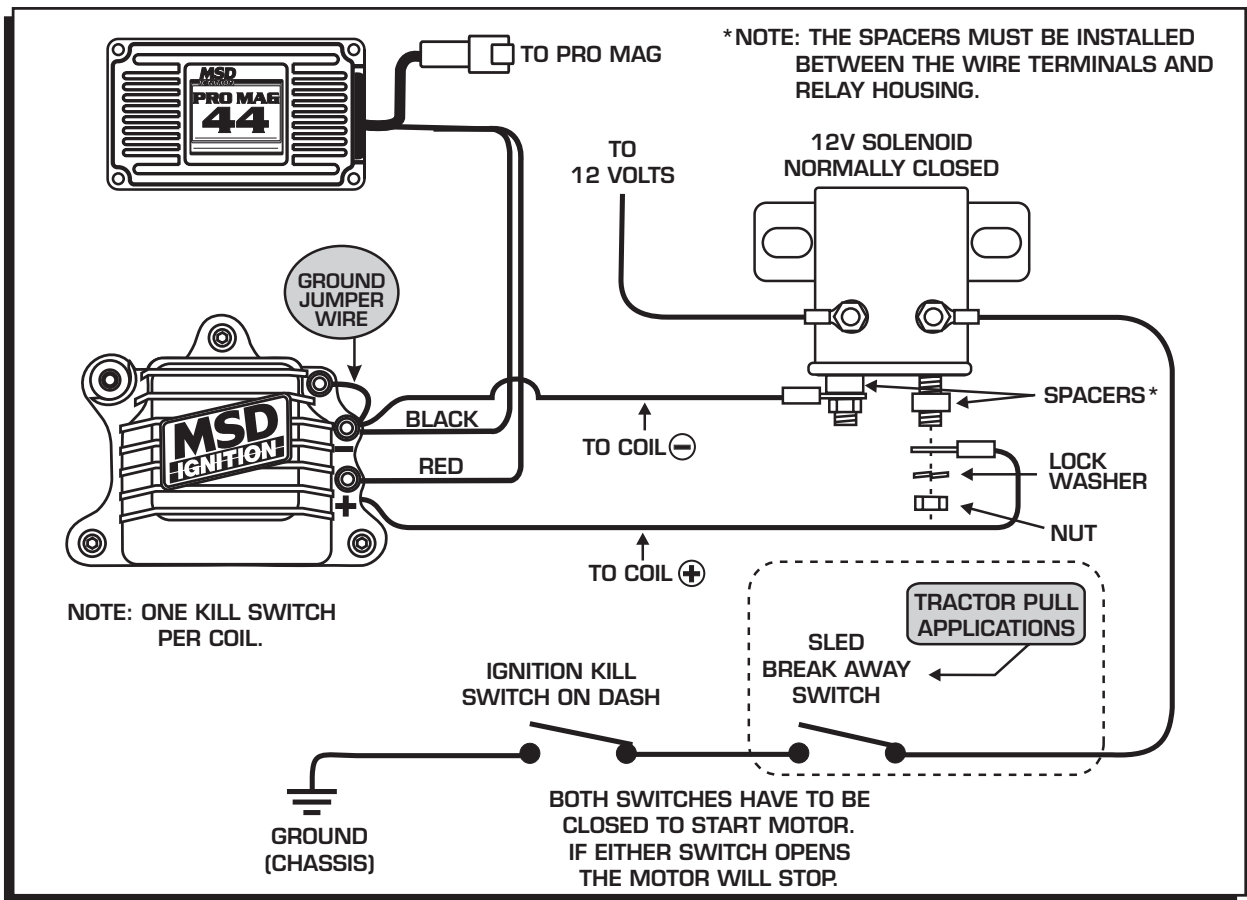

Figure 4 Typical Wiring on a Tractor Puller.

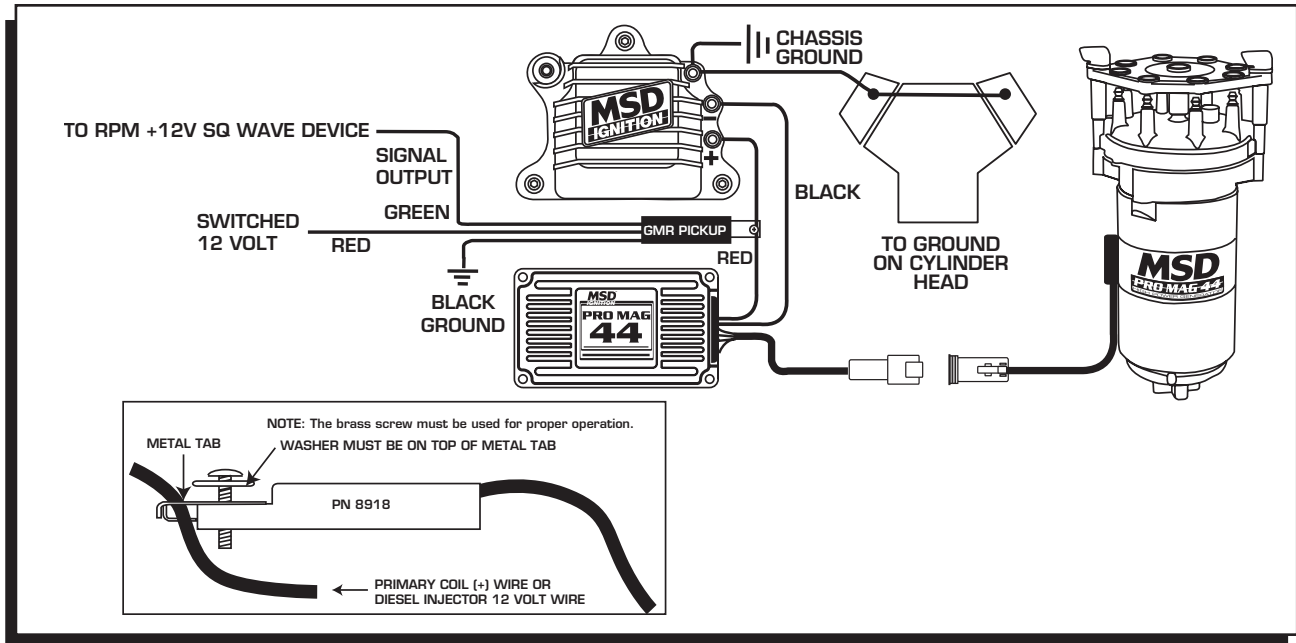
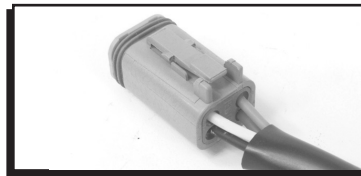

Figure 5 GMR to PN 8963 Shift Light on Pro Mag 44 Electronic Points Box.

WIRING AND CONNECTORS

MSD uses Deutsch connectors with the Pro Mag. These connectors should be inspected due to frequent disconnecting. Lightly pulling on the wires near the connector will make certain they have not worked loose. The connectors can be disassembled as follows:

1. Remove the orange wedge lock with a small flat blade screwdriver.
2. Pry the spring lock back to unlock the wire, and pull it through.
3. Inspect the wire crimps and reassemble.



12 and 20 Amp Mag Connector.



44 Amp Mag Connector.

Note that the connectors have numbered terminals. Match the color wire with the position as follows:

12 and 20 Amp			
#1 Violet	#2 Green	#3 Black	#4 Yellow

44 Amp			
#1 Violet	#2 Green	#3 Black	#4 Red

TACHOMETERS AND DATA ACQUISITION EQUIPMENT

Tachometers and data acquisition systems require a certain type of trigger signal. Most of these systems require either a 12-volt square wave signal or a current style inductive pickup. MSD has components that can provide both signal types.

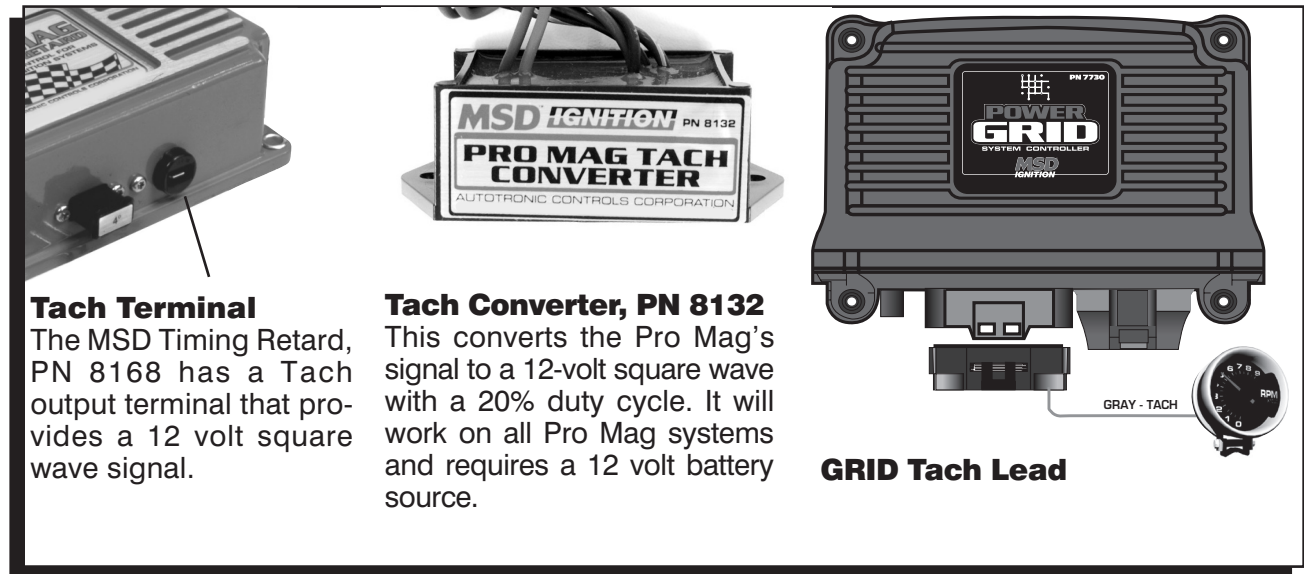

Figure 6 Wiring a Tachometer with the Tach Converter.

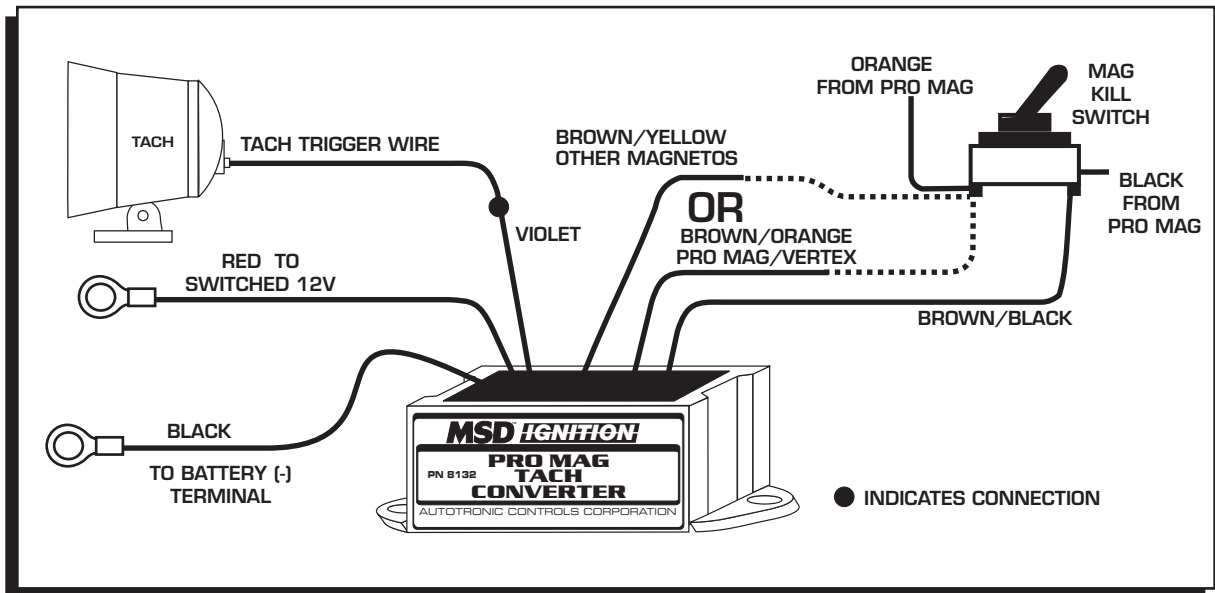

Figure 7 Wiring a Tachometer with the Tach Converter.

PRO MAG SERVICE

For repairs and component checks, you can send your Pro Mags to MSD.

CRANK TRIGGERS

Crank triggers are available for all MSD Pro Mag systems. For more information call the factory for specific applications.

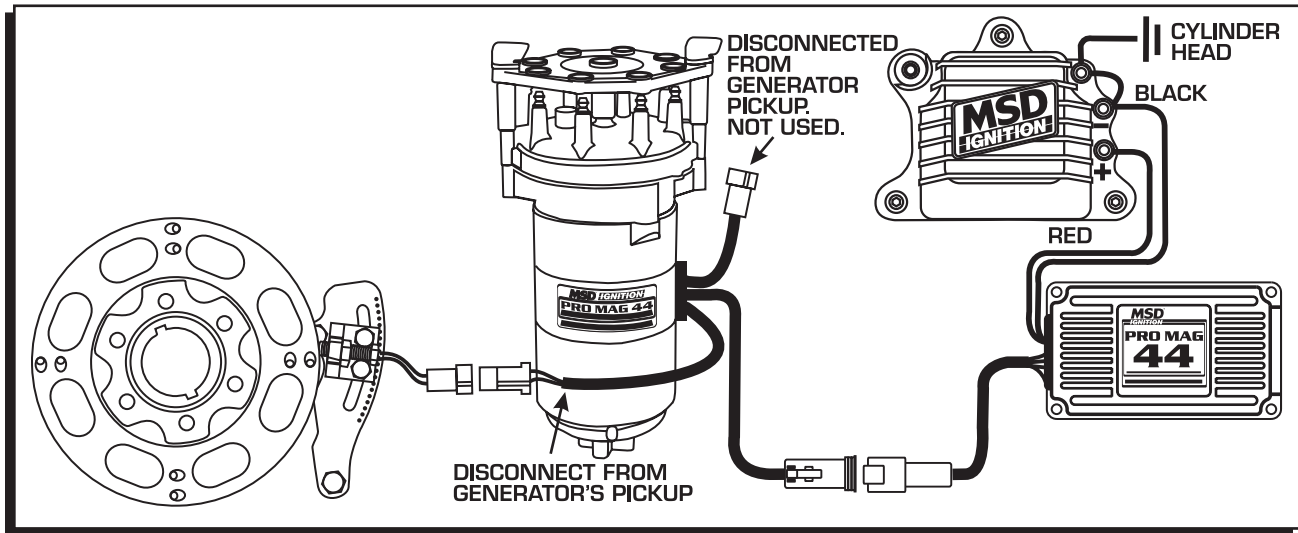

Figure 8 Crank Trigger Installation.

44 AMP GROUND PATH

Both heads must be grounded to a point on the chassis that is shared with the negative coil terminals. The Points Boxes should share ground with the PN 8168 Retard box (if used) which is also grounded to the battery and chassis.

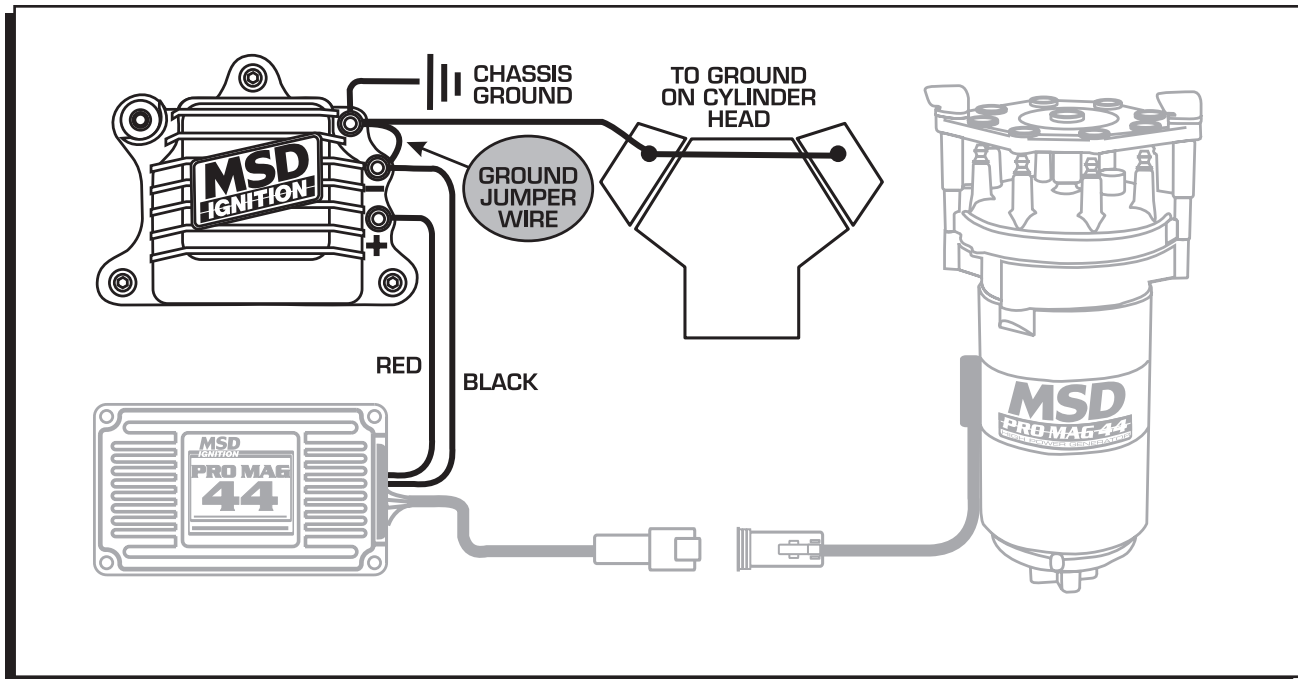

Figure 9 44 Amp Pro Mag Ground Path.

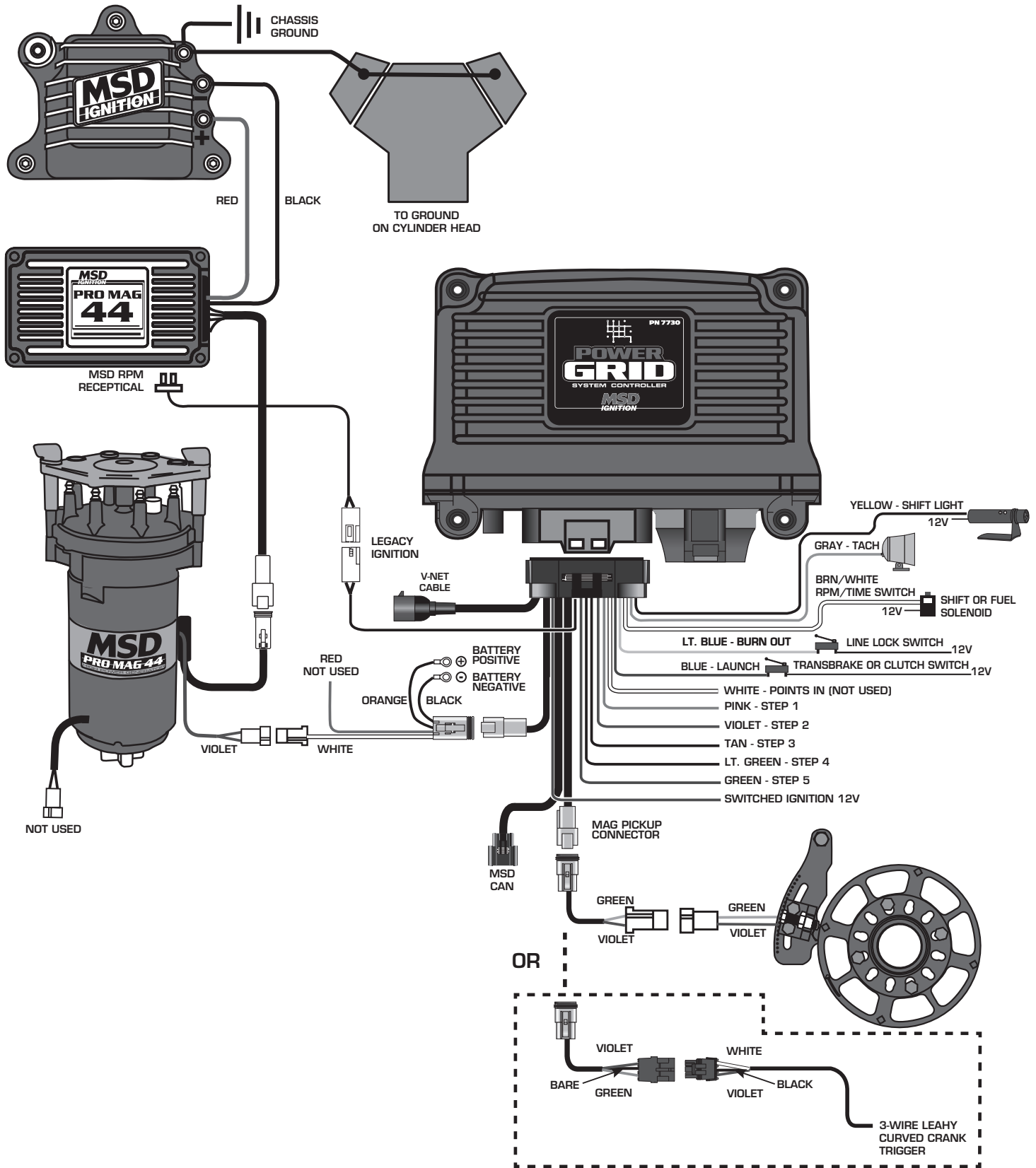

Figure 11