

MSD **IGNITION** **INSTALLATION INSTRUCTIONS**

Billet Distributor Hold Down Clamp **PN 8110**

Parts Included

- 1 - Billet Clamp
- 1 - 3/8" - 16 x 1" set screw
- 1 - 3/8" - 16 nut
- 1 - 3/8" Lock Washer
- 1 - 3/8" Flat Washer

Note: The position of the Billet Hold Down Clamp is imperative to its operation. The end points of the clamp must seat squarely on the intake manifold as well as the distributor collar.

INSTALLATION

1. Install the set screw into the intake manifold using a 3/16" Allen wrench.
2. Install the Billet Clamp, flat washer, lock washer and the nut on the set screw.
3. Position the clamp on the distributor collar and tighten the nut. Figure 1 shows the correct installation of the clamp. If the clamp is excessively angled and the end points of the clamp do not properly seat, the clamp will not tighten properly.

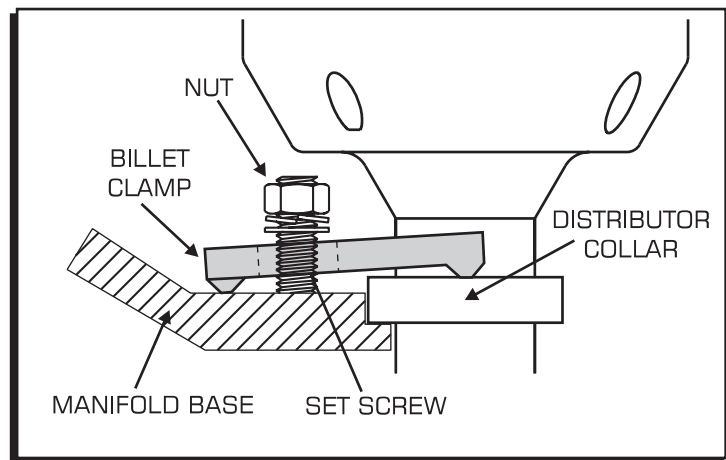

Figure 1 Correct Billet Hold Down Installation.