

# MSD INSTALLATION INSTRUCTIONS

## MSD Pro Mag 12 LT Chevrolet, PN 7908 Ford, PN 7915 Chrysler, PN 7910

### Parts Included:

1 - Pro Mag Lt	1 - Flat Washer
1 - Billet Clamp	1 - Nut
1 - Set Screw	2 - O-rings (PN 7908 only)
1 - Lock Washer	

1. Install the set screw into the intake manifold or engine block.
2. Install the magneto into the engine. On Chevrolet engines, position it so the hold down clamp will align with the housing's anti-rotation collar.
3. Install the billet clamp over the set screw and on to the collar of the magneto. Put the flat washer, lock washer and the nut onto the tud and tighten the assembly.

**Note:** On Chevrolet applications, it is recommended to locate the wiring harness of the generator towards the left side injector stack (Figure 1). This also puts the timing indicator of the magneto in a position that should be easy to view. Also position the band clamp's retaining screw so it points to the left and is in the back of the magneto, close to the firewall. On Ford and Chrysler engines, rotate the base until the pointer is easy to view.

4. Locate which cap terminal is going to be the number one cylinder. Mark on the housing this location then remove the cap (Figure 2).
5. Loosen the band clamp and position the generator so the rotor tip is just leading into the number one cylinder mark (from step 4) indicating the number one cylinder (Figure 3). This will put the timing approximately 2°-3° within TDC or where you have the timing set. **Note:** Always verify timing with a timing light.

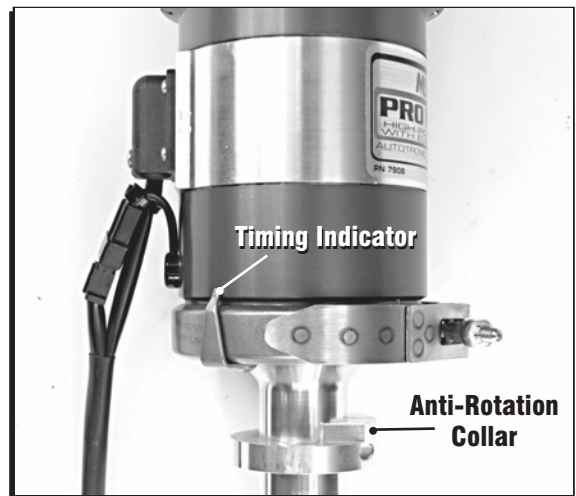

Figure 1 Positioning the Chevrolet Generator.

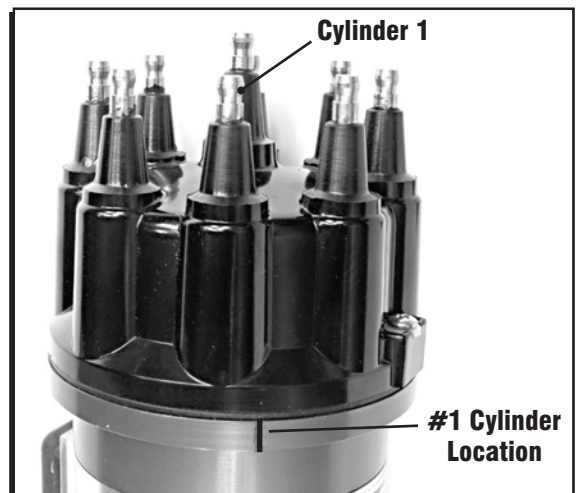

Figure 2 Marking the Number One Location.

Chevy/Chrysler - Clockwise Rotation

Ford - Counterclockwise  
Rotation

6. Install the cap and spark plug wires.



**Recommendation:** It is recommended on Chevrolet applications to put the number one cylinder in the position shown in Figure 4. The custom wire sets MSD offers are designed for this setup.

7. **Chevrolet applications only:** Install the gasket and apply a liberal amount of the supplied lubricant to the distributor gear and O-rings. (The supplied O-rings can **only** be used if the block has been modified as shown in Figure 5.)

### TIMING TAPE

There is a timing tape supplied with the Pro Mag. Once the timing is set and verified, apply the tape to the side of the generator aligning it with the pointer on the magneto base (Figure 6). This is not meant for exact timing changes, but will help for a guide when tuning.



Figure 3 Positioning the Rotor Tip.

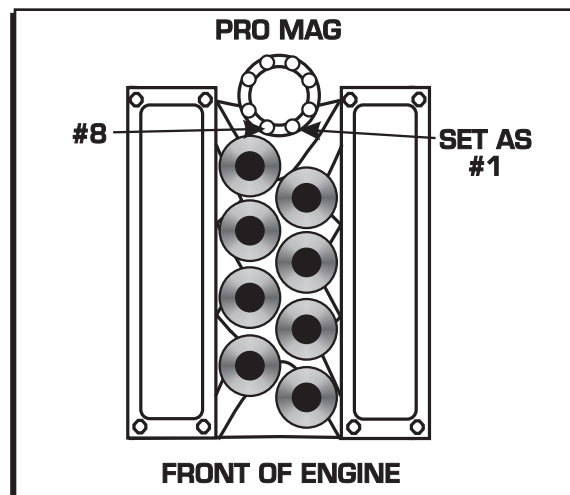

Figure 4 Recommended Chevrolet Installation Position.

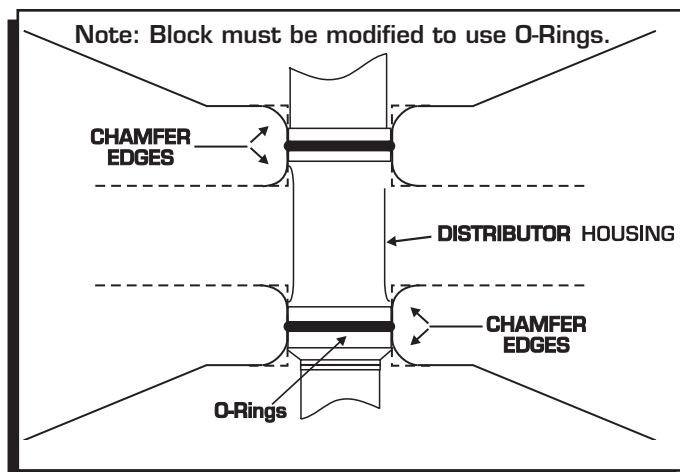

Figure 5 Chevy Blocks must be modified to accept O-rings.

**WIRING**

Figure 7 show the wiring of the Pro Mag system.

**Figure 7 Wiring the Pro Mag 12 Lt.**



**Figure 6 Applying the Timing Tape.**

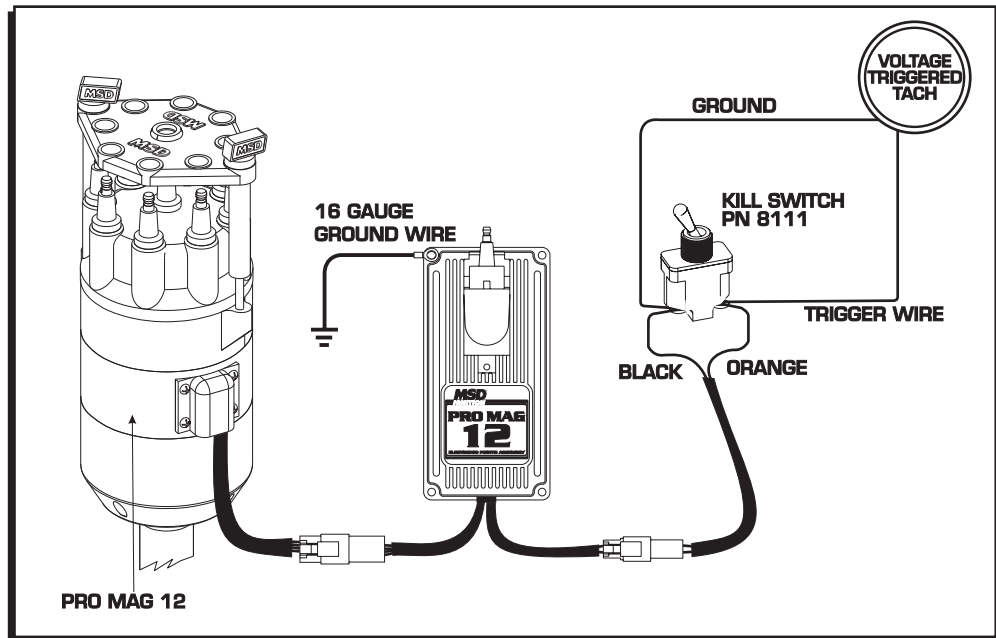

Maintenance Parts		
Cap/Rotor	-	PN 7909
Gears:		
Chevrolet	-	PN 8472 (.006" Oversized)
Chrysler	-	
Ford	-	PN 8585
Timing Tape	-	PN 7926
Kill Switch	-	PN 8111
Pro-Billet Clamps:		
Chevrolet	-	PN 8110
Chrysler	-	PN 8540
Ford	-	PN 8010
Band Clamp	-	PN 8146

MSD provides the best in performance ignition systems equipment.