



# INSTALLATION INSTRUCTIONS

## Street Fire GM HEI Cap/Rotor Kit PN 5501

### Parts Included:

- 1 - Cap
- 1 - Rotor

### INSTALLATION

1. Remove the cap and rotor. Remove the coil cover to remove the coil. (Note the position of the coil wires.)
2. Install the new rotor bushing and rubber isolator. The spring of the rotor bushing must face up (Figure 1).
3. Install the coil. The terminals should slide easily into position into the cap. The Yellow and Red leads go in the outer slots of the cap. Insert the Black ground wire in the center slot of the cap and connect it to one of the Coil's retaining screws (Figure 1). Install the other three coil retaining screws (Figure 1).
4. Install the new rotor. Make sure to position the aligning slot of the rotor to the tab on the rotor plate.
5. Install the cap assembly and connect the factory wiring.

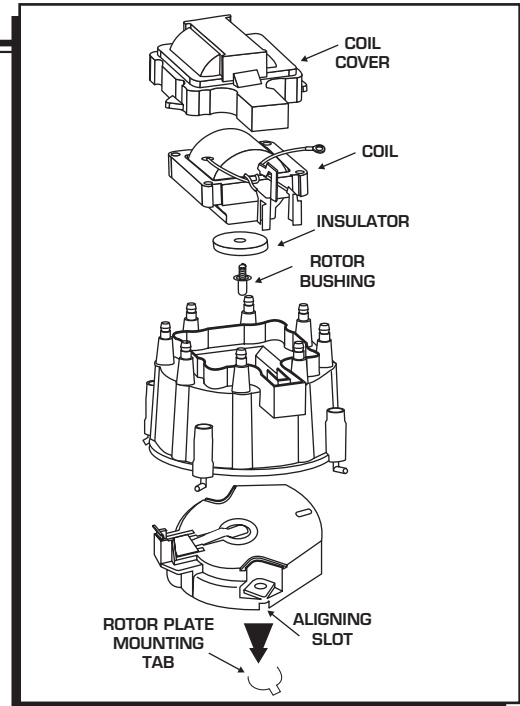

Figure 1 Installation.