

# **MSD** INSTALLATION INSTRUCTIONS

## **MSD DynaForce Starter Chrysler 318-440 Engines, PN 50981**

**IMPORTANT:** Proper installation of the DynaForce Starter is important to the overall operation. Correct alignment of the starter pinion with the ring gear is needed to achieve the best operation and longevity from your starter. Please read the instructions before attempting the installation.

### **Parts Included:**

1 - Starter      1 - Shim Ring      1 - Outer Shim

**WARNING:** Before installing the DynaForce Starter disconnect the battery cables. When disconnecting the battery cables, always remove the Negative (-) cable first and install it last.

Thank you for purchasing the DynaForce Starter from MSD. Please be sure to read, understand, and follow the instructions prior to installation so that everything goes smoothly and the engine starts reliably time after time.

## **INSTALLATION**

1. Make sure the starter mounting surface is clean and smooth.
2. Mount the starter and check that the position of the solenoid is away from direct heat sources and other components. If there are clearance problems, the starter housing can be rotated to move the location of the solenoid. This is done by removing the three bolts on the mounting block and repositioning the starter motor (Figure 1).

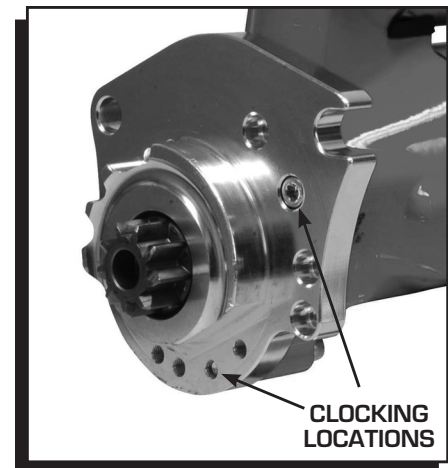

**Figure 1 Clocking the Starter  
for Clearance.**

3. After confirming clearances and position of the solenoid, it is time to check the pinion engagement to the ring gear. This is done by gently prying out the pinion gear to the ring gear. The pinion should engage by 1/4" minimum and 3/8" max on to the ring gear (Figure 2).
- **If there is not enough clearance**, you will need to install the supplied shim kit by removing the mounting block (Figure 3). If the pinion gear engages too far onto the ring gear, there will be issues with disengagement. MSD supplies a shim ring to move the pinion 0.060". Remove the mounting block and place the small shim ring in the bearing bore and install the outer shim on the support housing. Reinstall the mounting block. This will move the pinion gear into the starter approximately 0.060".
4. With the starter mounted and gear engagement confirmed, it is time to connect the wires. The switch wire that connects to the solenoid should be at least 12-gauge (Figure 4). For alternative wiring to incorporate the factory remote solenoid, See Figure 5.
5. Attach the battery cable. The gauge of the battery cable depends on its length. Using the proper gauge wire is important to the operation of the starter. Both the positive and ground wires must be able to meet the demands of the starter. The chart in Figure 5 shows the recommended sizes. Be sure to route the wire away from the exhaust and moving parts of the engine.
6. Connect the battery terminals and start the engine.

**IMPORTANT:** Never operate a starter for more than 30 seconds at a time without letting it cool for at least two minutes.

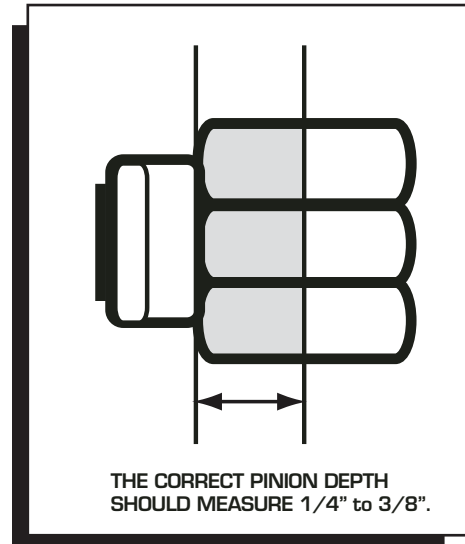

Figure 2 Pinion Gear Pattern.

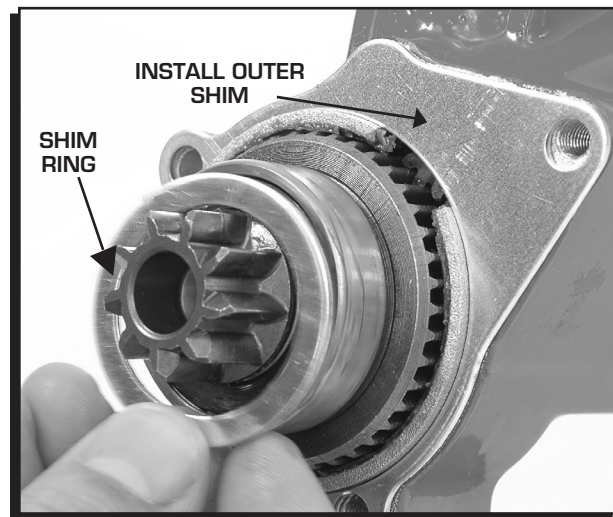

Figure 3 Installing the Pinion Shim Spacers.

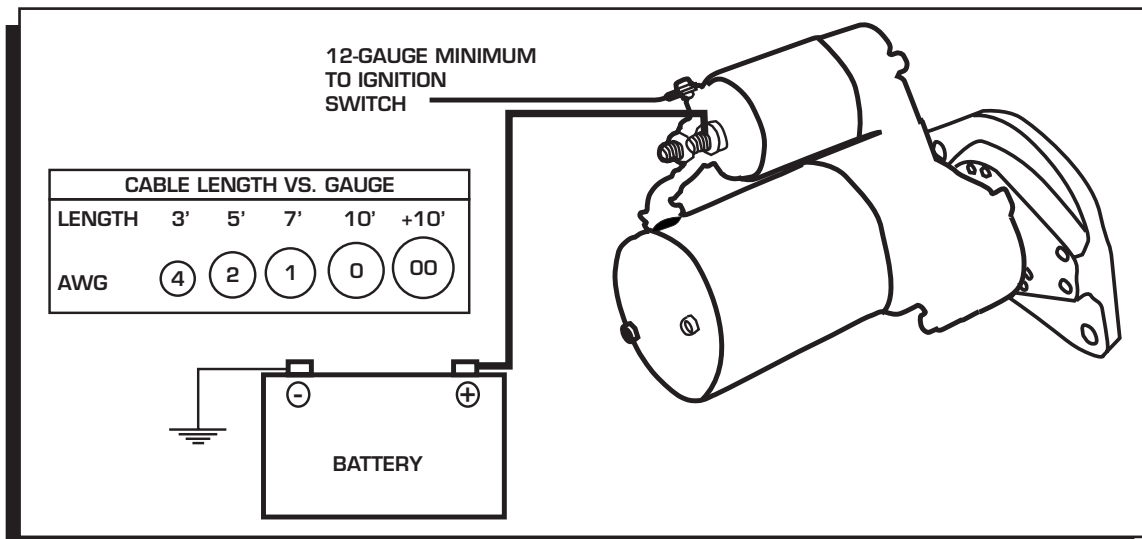

Figure 4 Wiring the DynaForce High Speed Starter.

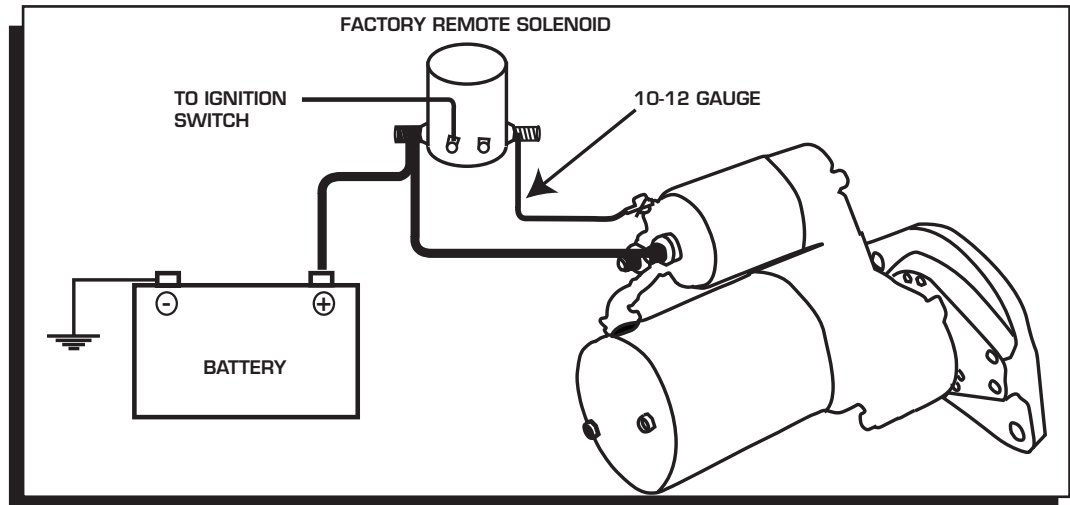

Figure 5 Wiring to Incorporate an External Solenoid.

## INSTALLATION INFO

### **SLOW CRANKING**

The most common cause is due to low input voltage. The battery should be checked, but also inspect the battery wires, terminals, connections or switches.

### **DISCONNECT SWITCHES**

Most sanctioning bodies require an emergency disconnect switch. Be sure to use a heavy duty switch that is capable of handling high current. Some starters may pull over 700 amps while cranking. Most disconnect switches are rated at continuous and intermittent amps. Make sure to use a switch that exceeds your starting and electrical system requirements.