

# **INSTALLATION INSTRUCTIONS**

## **MSD DynaForce Starter Ford FE, PN 5093**

**IMPORTANT:** Proper installation of the DynaForce Starter is important to the overall operation. Correct alignment of the starter pinion with the ring gear is needed to achieve the best operation and longevity from your starter. Please read the instructions before attempting the installation.

### **Parts Included:**

1 - Starter

1 - Shim Ring

1 - Outer Shim

**WARNING:** Before installing the DynaForce Starter disconnect the battery cables. When disconnecting the battery cables, always remove the Negative (-) cable first and install it last.

## **INSTALLATION**

1. Make sure the starter mounting flange on the mid plate is clean and smooth.
2. Before mounting the starter, measure the distance from the front of the ring gear (engine side) to the starter mounting surface. It should be  $11/16"$  -  $3/4"$  (Figure 2).
  - **If there is not enough clearance**, you will need to install the supplied shim kit by removing the mounting block (Figure 3). Place the small shim ring in the bearing bore and install the outer shim on the support housing. Reinstall the mounting block. This will move the pinion gear into the starter approximately  $0.060"$ .
3. Check that the position of the solenoid is away from direct heat sources and other components. If there are clearance problems, the starter housing can be rotated to move the location of the solenoid. This is done by removing the three bolts on the mounting block and repositioning the starter motor (Figure 1).
4. After confirming clearances and positioning. Mount the starter.
  - **If there is not enough clearance**, you will need to install the supplied shim kit by removing the mounting block (Figure 3). Place the small shim ring in the bearing bore and install the outer shim on the support housing. Reinstall the mounting block. This will move the pinion gear into the starter approximately  $0.060"$ .
  - The gear mesh is not adjustable on this application. Verify that all parts are correct for the application (flywheel, block plate, starter) and verify starter is mounted correctly to engine plate.

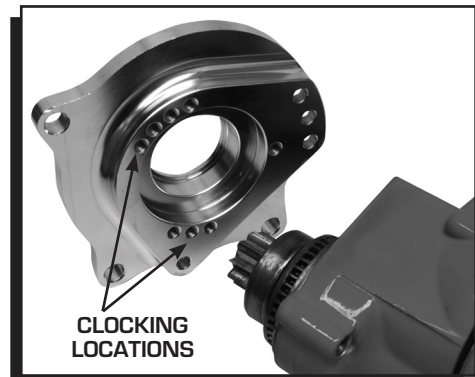

**Figure 1 Clocking the Starter for Clearance.**

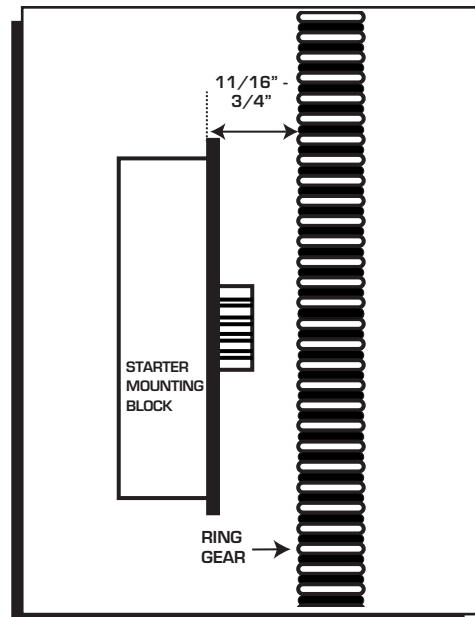

**Figure 2 Checking Pinion Clearance.**

5. The switch wire that connects to the solenoid should be at least 12-gauge (Figure 4). For alternative wiring to incorporate the factory remote solenoid, See Figure 5.

**Note:** If your original starter had wire going to a second terminal, an 'R' terminal, this can generally be bypassed. See the information on the last page of the instructions for more details.

6. Attach the battery cable. The gauge of the battery cable depends on its length. Using the proper gauge wire is important to the operation of the starter. Both the positive and ground wires must be able to meet the demands of the starter. The chart in Figure 5 shows the recommended sizes. Be sure to route the wire away from the exhaust and moving parts of the engine.

7. Connect the battery terminals and start the engine.

**IMPORTANT:** Never operate a starter for more than 30 seconds at a time without letting it cool for at least two minutes.

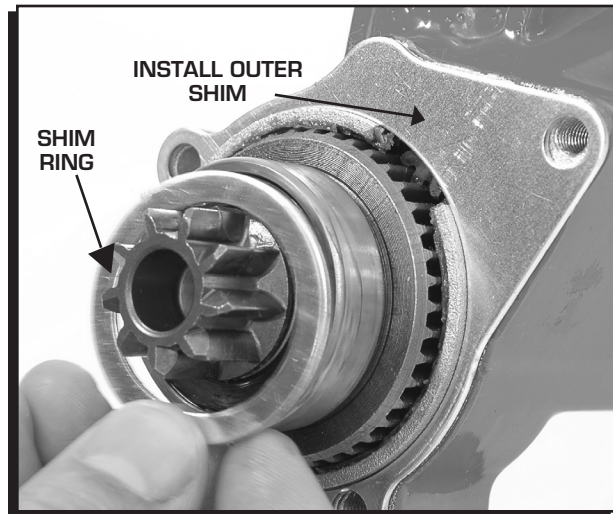

Figure 3 Installing the Pinion Shim Spacers.

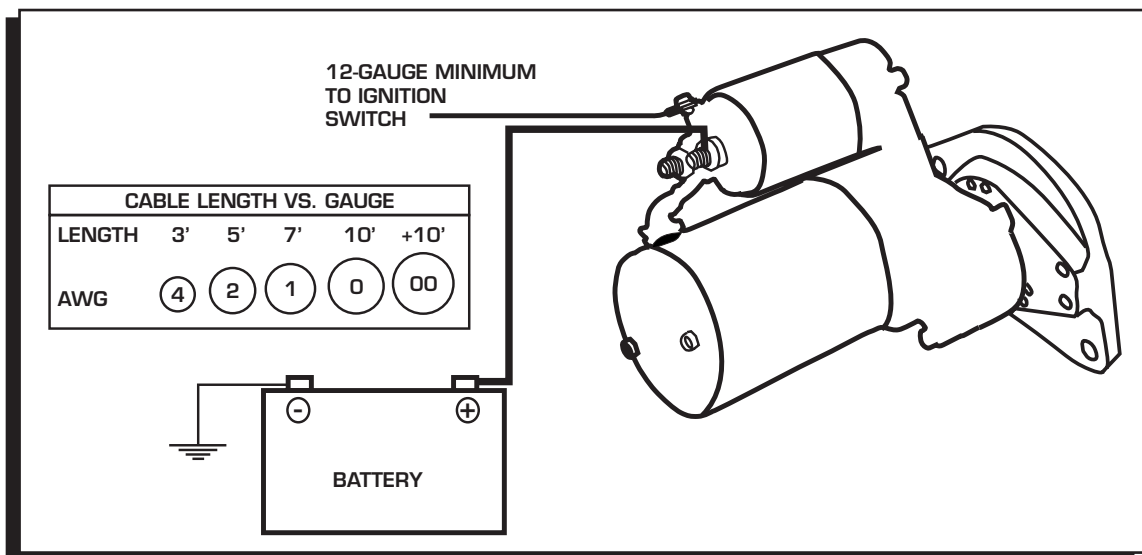

Figure 4 Wiring the Starter.

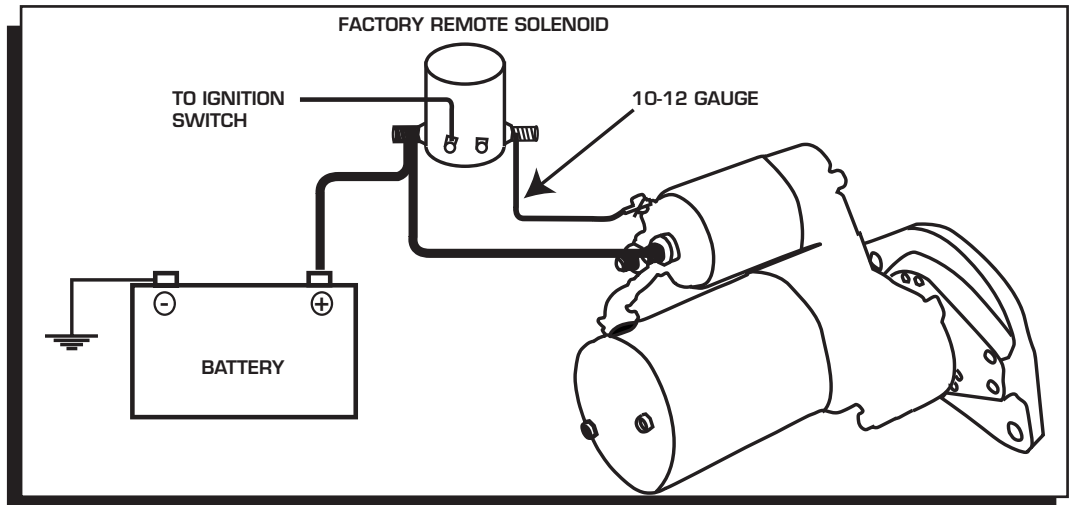

Figure 5 Wiring to Incorporate Factory Solenoid.

## INSTALLATION INFO

### INSPECT PINION GEAR

After cranking the engine several times, you can inspect the witness pattern on the pinion gear. The pattern should show 1/4" to 3/8". If over, the internal shim is required.

### SLOW CRANKING

The most common cause is due to low input voltage. The battery should be checked, but also inspect the battery wires, terminals, connections or switches.

### DISCONNECT SWITCHES

Most sanctioning bodies require an emergency disconnect switch. Be sure to use a heavy duty switch that is capable of handling high current. Some starters may pull over 700 amps while cranking. Most disconnect switches are rated at continuous and intermittent amps. Make sure to use a switch that exceeds your starting and electrical system requirements.

### R-TERMINAL

On older vehicles, mostly with breaker points, there was an extra terminal and wire on the original starter (the MSD DynaForce Starter does not have this terminal). This extra terminal served as a ballast resistor bypass. When the starter was cranking, 12 volts would be supplied on this terminal and directly to the coil positive terminal for starting assistance. Most ignition systems today do not need this terminal, however, if your ignition has no voltage when cranking you can wire a system. Connect a 10A/250V diode in-line with the motor side of the solenoid. The banded end of the diode goes away from the starter. This allows current to go to the ignition coil during cranking and will not feed back to the starter while the engine is running.

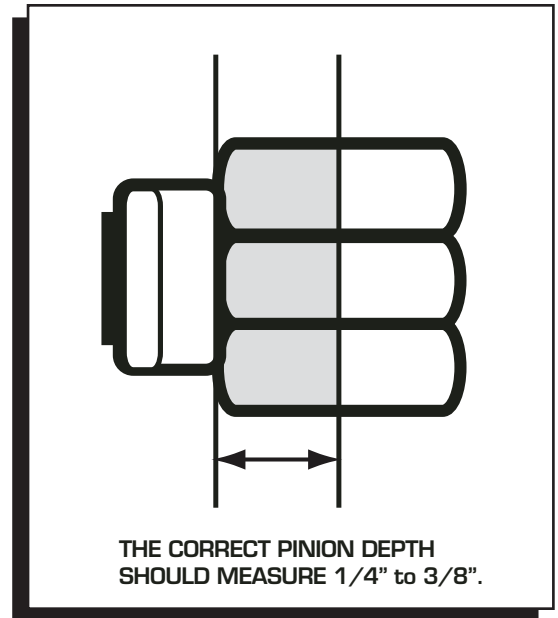

Figure 6 Pinion Gear Pattern.