

MSD INSTALLATION INSTRUCTIONS

MSD Analog Air/Fuel Wideband O2 Gauge PN 4650, 2-1/16" 8.5-18 (Black) PN 4651, 2-1/16" 8.5-18 (White)

Parts Included:

- 1 - 2-1/16" 8.5-18 Gauge
- 1 - 6-Pin Gauge to O2 sensor harness (5-foot length)
- 1 - Wideband O2 Sensor

MSD fully standalone unit provides accurate air/fuel ratio measurement for all carbureted and EFI fuel systems. Kit utilizes a Bosch LSU 4.9 wideband O2 sensor & is compatible with all fuel types (Unleaded, Leaded, E85, Methanol, or Diesel).

INSTALLATION INSTRUCTIONS:

1. Disconnect negative (-) battery cable.
2. Mount gauge in desired location. Use included spin ring to mount it on the dash panel.
3. Connect 5 foot wiring harness to the gauge
4. Connect Red wire to a switched 12v. **Note: Power needs to be connected to a switched 12v source not common with other accessories.**
5. Connect White wire to 12v Dash lighting.
6. Connect Black wire to ground.

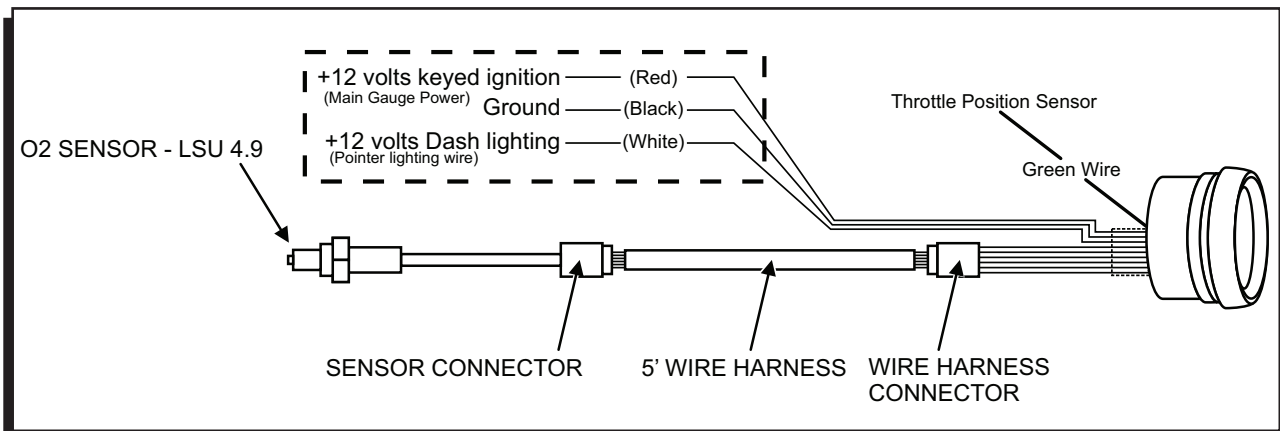

Figure 1

7. Install O2 sensor. See 'Mounting the O2 Sensor - LSU 4.9' (Figure 3)
8. Connect the O2 harness to the included gauge harness. (Figures 1)
Note: The gauge will not start to warm up the sensor until the gauge sees 13.5v or higher voltage
Note: While the gauge is warming up the sensor, the gauge pointer will oscillate between 14-15 on the dial.
The warm-up procedure should take between 15-30 seconds
9. Reconnect negative (-) battery cable.

Throttle Position Sensor (TPS) – **Note:** The wide band gauge can be hooked up to the TPS sensor via the green gauge wire. This feature enables the warning light ONLY during W.O.T. (Wide Open Throttle). The light will not work at any other time.

Setting LED Warning Zones:

The LED can be set to warn of a lean or rich condition by either turning On or Off. The factory default is 'Off'.

LED Warning Zone Set Mode:

1. Press and hold gauge button with the gauge powered Off.
2. Turn On gauge power. Release the button when LED turns On. The Pointer will travel to a full Rich condition, and slowly scan clockwise. Press button at desired Rich setting.
3. LED will blink to indicate Rich warning zone is set.
Note: Pressing button at full Rich position on dial will disable the rich LED warning zone.
4. Pointer will then travel to full lean condition and slowly scan counter clockwise. Press button at desired Lean setting.
5. LED will blink to indicate Lean warning zone is set.
Note: Pressing button at full Lean position on dial will disable the lean LED warning zone.

Note: Setting a rich or lean warning zone will turn LED On above or below set points. To reset LED warning zone, follow the LED warning zone set mode steps.

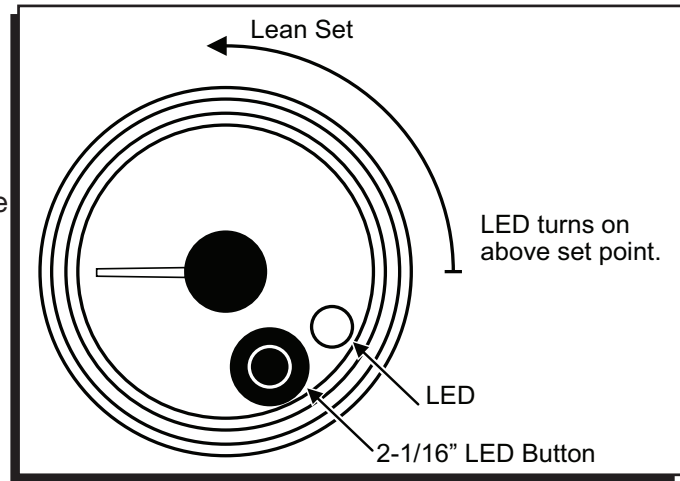

Figure 2

Setting LED Brightness for Day and Night:

The Gauge has a day and night LED setting. The Day LED brightness level is set with the gauge lighting Off. The night LED brightness level is set with the gauge lighting On.

Note: The LED brightness has 5 settings including Off.

To show current LED setting, press and release the LED button while gauge is powered On.

When the gauge is powered On, the current setting is saved if the LED button is not pressed in 3 seconds after being powered. The LED will blink to indicate settings have been saved.

To Change LED Brightness:

1. Press and release the LED button to increase the brightness.
2. Press the button until desired LED brightness is selected.
3. The LED will blink to indicate the setting has been saved after 3 seconds.

Maximum Lean Recall:

Press and hold program button down for two seconds. The gauge needle will display the maximum lean value recorded. Gauge needle will display the value as long as the program button is pressed.

To Retain Maximum Lean Reading:

While showing maximum reading, release button for 5 seconds, gauge will return to normal retain and maximum lean reading.

To Clear Maximum Lean Reading:

While showing maximum lean reading, release button, and immediately press and release again within 5 seconds. LED will flash 2 times and pointer will travel to full rich to indicate value has been cleared.

Gauge Notes:

- When gauge power is off the pointer (needle) will remain in last powered position.
- Variable Power Draw is 100mA to 3A.

100mA - During normal gauge operation, 3A - Max current draw during initial O2 heating cycle, 3A to 5A inline fuse recommended for +12 Keyed Ignition.

Mounting the O2 Sensor - LSU 4.9:

The range of acceptable O2 sensor mounting positions is shown in **Figure 3**. Install the O2 Sensor between 15 degrees from the vertical, and 10 degrees from the horizontal. The sensor should be perpendicular to the gas flow, i.e. the bung should sit square over the pipe - this ensures adequate amount of gas enters the sensor.

Note: A vertical position can get too hot in confined spaces. A horizontal position can cause condensation to drip onto the sensor.

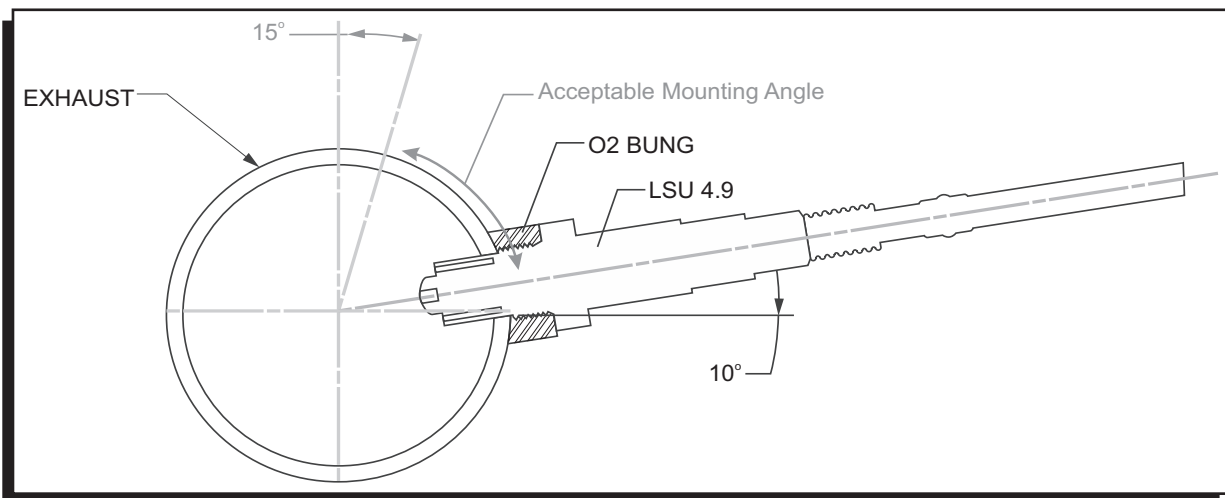

Figure 3

*It is recommended to install the O2 sensor no farther than 40 inches (1 meter) from the closest exhaust valve.