



# INSTALLATION INSTRUCTIONS

## Universal Wire Set for GM GEN III Engines PN 32079 / PN 32073

### Parts Included In This Kit:

- 8 - [Spark Plug Wires with 90° and Multi-Angle Boots](#)
- 9 - LS1 Boots and Terminals
- 1 - Mini-Stripper-Crimper

### Tools Required:

- Razor Blade
- Vise (4" Minimum)
- Needlenose Pliers

### Optional:

- PN 35051 Pro Crimp Tool

This Universal Wire set gives you the choice of using a 90° or straight/Multi-Angle boot and terminal on the spark plug to accommodate for the header variances. Once you have determined the style boots to use, you can cut the new wires to length then install the correct supplied coil terminal and boot. A Mini-Stripper-Crimper Tool is supplied to help you achieve a strong, factory type crimp.

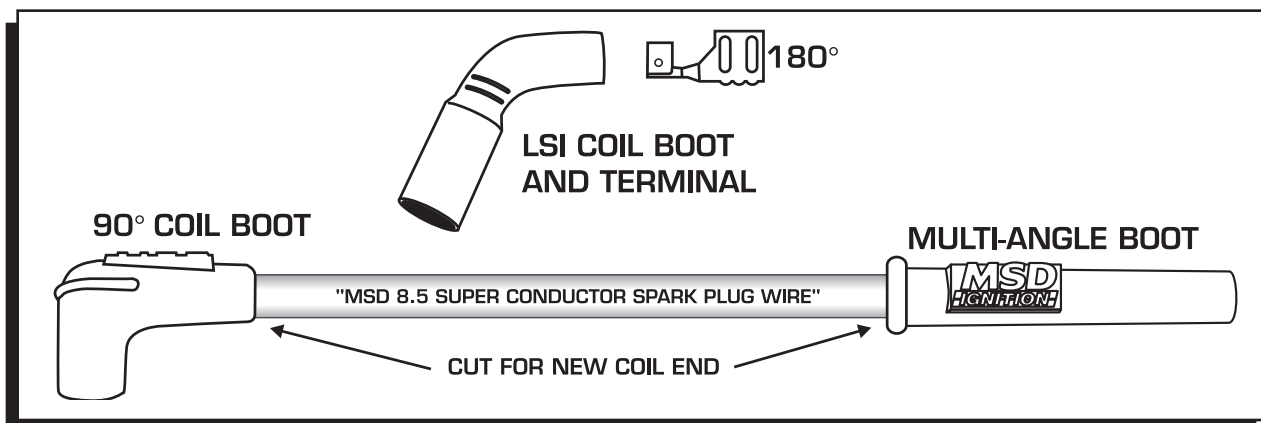

Figure 1 Choosing the Spark Plug Boots and Terminals.

1. Once you've determined wire length and spark plug boot to use, position the wire in the corresponding strip guide of the strip tool.
2. There are two stripping positions on the stripping slot, when installing the LS1 terminal it will require you to strip the wire at standard terminal length (Figure 2).
3. Remove the wire and twist the cut sleeve off in a counterclockwise direction.

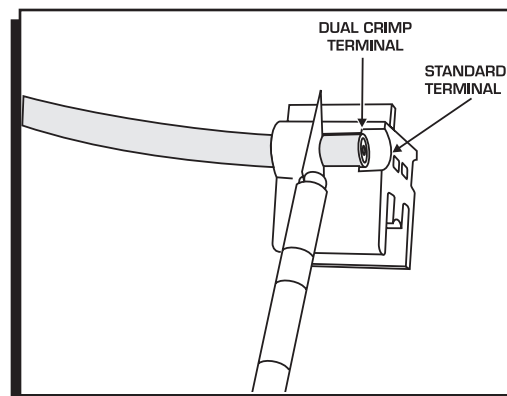
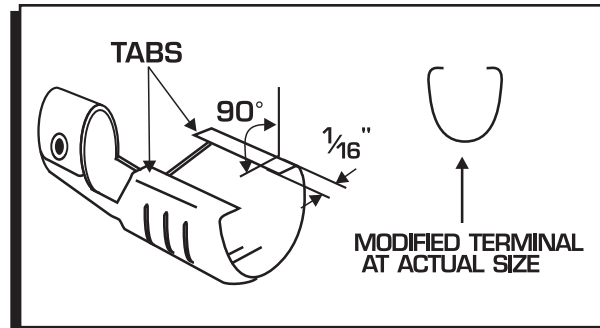

Figure 2 Stripping the Sleeve.

4. To achieve the strongest crimp possible, it is required to bend the crimp tabs over about 90° using needle nose pliers. Figure 3 shows an example.



**Figure 3 Stripping the Sleeve.**

5. Bend the conductor back along the wire insulation. Slide the wire into the terminal with the conductor positioned so it is in contact with the bottom of the terminal (Figure 4). Push the wire through until the sleeve protrudes about 1/8" beyond the crimp tabs.

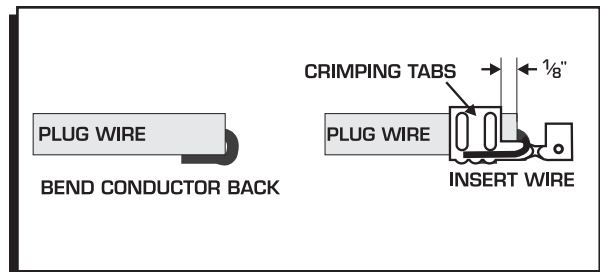

**Figure 4 Preparing the Terminals.**

6. Position the wire and terminal into the "W" groove side of the Mini-Stripper-Crimper. Align the crimp tabs so they are exactly centered on the tip of the crimp die (Figure 5).
7. Slide the other part of the Mini-Stripper-Crimper over the wire terminal and lightly press them together.
8. Put the assembly into a vise making sure the alignment tabs are on the outside edge of the vise jaws (Figure 6).

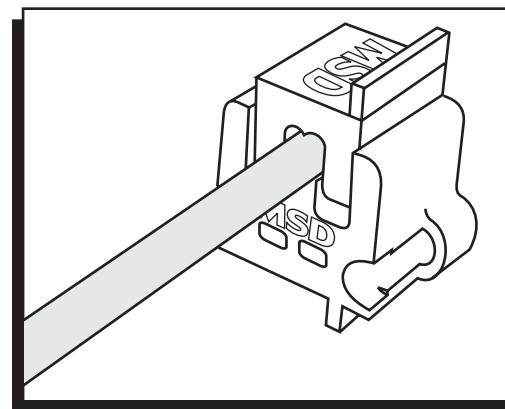

**Figure 5 Aligning the Terminal in the Tool.**

9. Slowly close the vise making sure the tool and terminal stay properly positioned and aligned (Figure 6). Stop applying pressure when the terminal ends have wrapped securely around the sleeve and grip the wire.

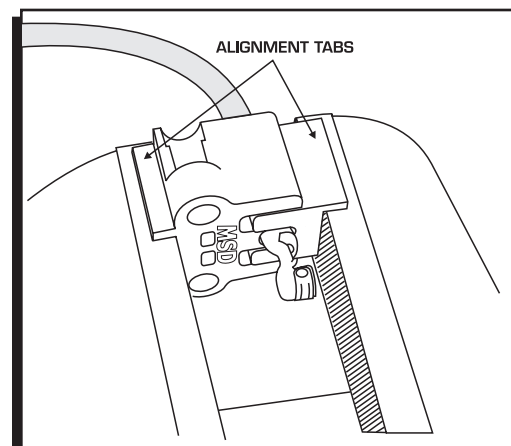

**Figure 6 Aligning the Terminal in the Tool.**

**Note:** DO NOT OVER-CRIMP! It is possible to tear the sleeve of the wire by excessive pressure on the vise. This will cause a weaker crimp.

10. Back off the vise and remove the wire from the Crimper. Gently tug the terminal and inspect the position of the conductor to make sure the crimp is solid and firm.
11. To ease installation of the boots, use a drop of a dielectric grease such as MSD's Spark Guard, PN 8804. A can of spray silicone will also work well. Proceed with inserting the wire into the boot (Figure 7).

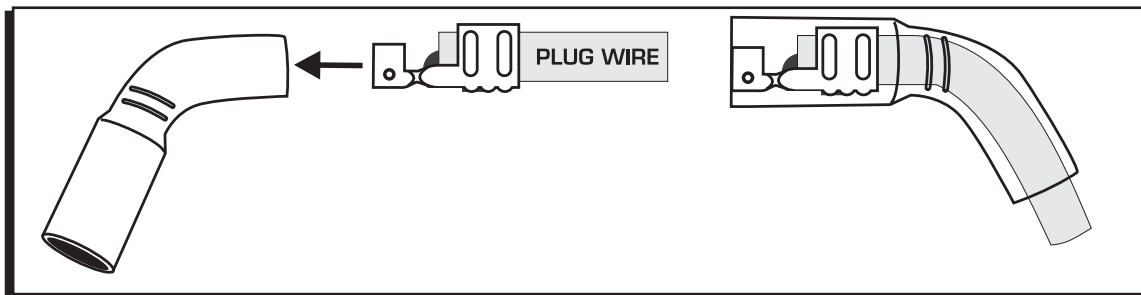

**Figure 7 Boot & Installation and Terminal Depth.**