



INSTRUCTIONS for M.O.R.E.™ BLJK4D 1" BODY LIFT KIT



This M.O.R.E.™ One Inch Body Lift Kit fits 2008 Jeep® JK® Wrangler® vehicles with manual* or automatic transmissions and with or without air conditioning. This kit has been designed to fit on JK Wrangler's that are stock (no suspension lift), or Wrangler's that have been lifted with aftermarket suspension lift kits up to 6". Familiarize yourself with all components in this kit and the parts of your Jeep that you will be working on. Common hand tools are required and some mechanical knowledge is recommended.

* May be necessary to trim inner shifter boot if you have contact in 2nd, 4th and reverse.

This kit contains the following items:

<u>Quantity:</u>	<u>Description:</u>	<u>Size:</u>	<u>Location:</u>
10	Puck-Aluminum	2-1/4" x 1" 1/2" hole	1-10
2	Puck-Aluminum	2-1/4" x 1" 9/16" hole	11-12
10	Bolt	12-1.75x130mm	1-10
2	Bolt	14-2.0x130mm	11-12
2	Lock Nut	12-1.75mm	1,2
2	Flat Washer	1/2" USS	1,2
2	OEM Body Mounts		1,2

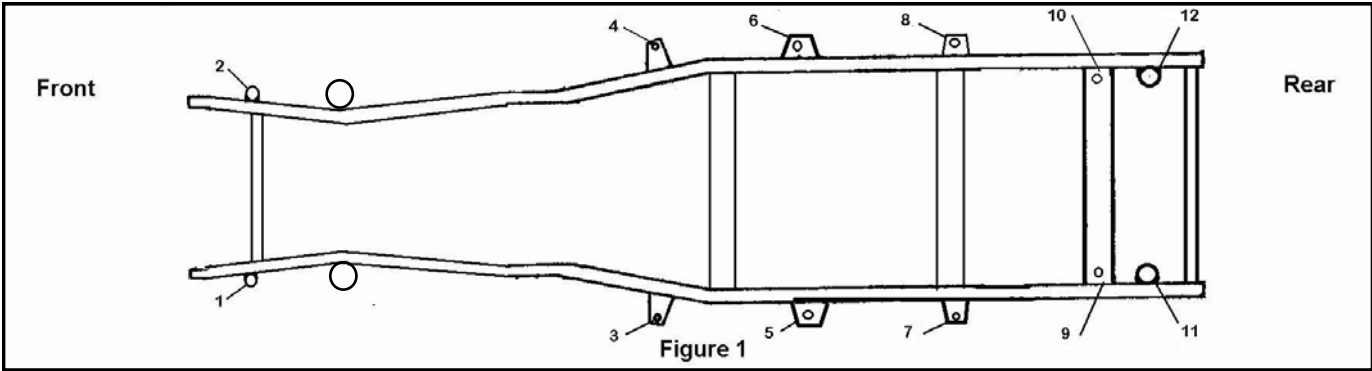

1. Remove the grille facia by removing the plastic screw retainers and carefully pull forward on the bottom to release the snap clips. Remove the turn signal electrical connectors and grille facia is able to be removed (See figures 2, 3 & 4)
2. Follow the wires coming from the oxygen sensor on the drivers side exhaust manifold up to the connector (close to the Brake master cyl.). Pull the connector out of it's locating hole to allow slack once the body is lifted up. (see Figure 5)
3. Loosen all 12 body mount bolts. Remove 5 bolts and 1 nut (Position # 1) on the driver's side. You will need to remove the large washers from the stock bolts. This is easiest done by supporting the washer over the jaws of a vise and hammering down on the bolt . (See Figures 6 & 7)
4. Place a stout piece of wood on a floor jack and place the jack between body mount 3 and 5 on the DS channel portion of the body. Jack up the body just enough to install the 1 inch pucks on top of the factory rubber insulators. On position 1 & 2 you will need to remove the factory body mount (Figure 8), you will then need to remove the washer from the factory body mounts (See Figure 9). Now place the supplied body mounts in to position 1 & 2, the supplied 1/2" uss flat washers will be placed under the body mount outrigger. (See Figure 10 for proper sequence of pucks and body mount in positions 1 & 2).Place the M.O.R.E.™ pucks in locations 1,3,5,7,9,11. It is recommended that you use a dab of lock-tight on the new longer bolts. Start the new longer bolts with the large washers in locations 1,3,5,7,9,11 (See Figure 11 For proper sequence of pucks and hardware in all remaining locations). Do not tighten at this time. **See Figure 1 for locations of body mounts. On 2008 Jk's you will need to install the 2 pucks with the 9/16" holes in locations 9-10 and install the larger 14mm bolts.**
5. Repeat steps 3 & 4 on the passenger side of the body.
6. Now, tighten the new longer body mount bolts. Use your judgment as to how tight to torque the bolts. Do not "crush" the rubber insulators or leave the bolts too loose!
7. Go back and re-check all of your work. Make sure that all the bolts are tight and nothing has been left "un-done". Re-check the body bolts after 4-Wheeling and every few months. Thank you for purchasing this product from M.O.R.E.™.

Figure 2

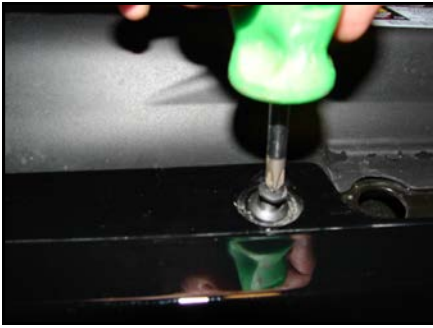

Figure 3



Figure 4

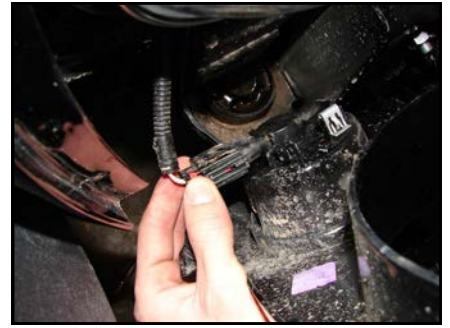

Figure 5



Figure 6



Figure 7



Figure 8



Figure 9



Figure 10

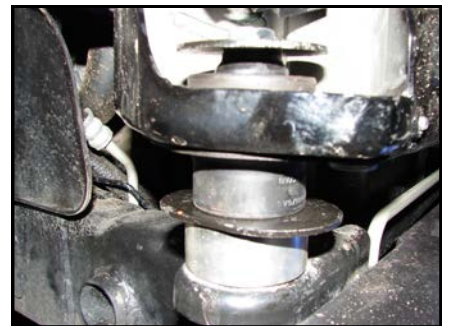

Figure 11



MORE!
Mountain-Off-Road-Enterprises