

Motive Gear

Table of Contents

TRANSMISSION

	<i>Page</i>
TYPE: AMC	
AX5	3-5
AX15 6-8	
BA10 PEUGEOT	9-10
T5 NON-W/C	11-15
T5 W/C	16-21
T18	22-27
T19	28-33
T150	111-113
T170	114-117
TYPE: CHEVROLET	
A833/MY6	34-37
M21/M22	38-40
NP435	41-43
NV1500	44-45
NV3500	46-53
GETRAG INPUT & CLUSTER I.D. CHART	54-55
NV4500	56-61
SM465	62-65
T10	66-69
T56	70-75
T5 NON-W/C	11-15
T5 W/C	16-21
TYPE: DODGE	
AX5	3-5
AX15 6-8	
A833 /MY6	34-37
G360 76-77	
NP435	41-43
NP535	78-80
NV3500	46-53
NV4500	56-61
NV5600	81-82
TYPE: FORD	
FM145/FM146/FM132	83-86
M5R1	88-91
M5R2	92-95
NP435	41-43
S5-42/47	96-100
S5-47M	101-103
S6-650	104-107
T5 NON-W/C	11-15
T5 W/C	16-21
T18	22-27
T19	28-33
T45	108-110
T56	70-75
T150	111-113
T170	114-117
TOYO-KOGYO	118-120
TR3550	121-124
TR3650	125-128
ZF® PARKING BRAKE	129

FOREIGN APPLICATIONS

TYPE: HONDA®	130
TYPE: ISUZU® TRUCK	131
TYPE: MITSUBISHI®	132
TYPE: NISSAN® RSSF30A	133
TYPE: NISSAN® FS5R30A (V6)	134-135
TYPE: NISSAN® FS5W71	136-138
TYPE: TOYOTA®	
G52	139-141
L52	142-143
W56	144
TYPE: VW® JETTA	145

MISCELLANEOUS

TRANSMISSION KIT REFERENCE GUIDE	146-153
--	---------

Table of Contents

TRANSFER CASE

	<i>Page</i>
TYPE: AMC	
NP208	155-157
NV219	158-160
NV228/229.....	161-162
NV231/233.....	188-191
NV242J/DHD	163-166
NV247/249J	167-169
TYPE: CHEVROLET	
BW1370	170-172
BW4470	173-175
BW4472	176-177
NP203	178-180
NP205	181-183
NP208	155-157
NV136	184-185
NV149	186-187
NV231/233.....	188-191
NV236/246.....	192-193
NV241	194-197
NV243	198-200
NV261/263.....	201-204
TYPE: DODGE	
NP203	178-180
NP205	181-183
NP208	155-157
NV231/233.....	188-191
NV241	194-197
TYPE: FORD	
BW1350	205-207
BW1345	208-210
BW1354	211-213
BW1356	214-217
BW4404	218-219
BW4405	220-222
BW4406	223-226
BW4407	227-228
BW4410	229-230
BW4411	231-233
BW4416	234-235
DANA28	236
NP203	178-180
NP205	181-183
NP208	155-157
NV271/273.....	237-239
TRANSFER CASE KITS	240-243
NEW PROCESS / NEW VENTURE TRANSFER CASE CHAINS.....	244-245
BORG-WARNER TRANSFER CASE CHAINS.....	246-247
MISCELLANEOUS IMPORT TRANSFER CASE CHAINS	247
FLUID GUIDE.....	248
UNIT GUIDE	249-272
<hr style="border: 0.5px solid black;"/>	
FREIGHT POLICY	273
WARRANTY - REMANUFACTURED TRANSMISSIONS & TRANSFER CASES	274
PARTS WARRANTY	275

AX5 STYLE

JEEP® CHEROKEE, COMANCHE 1984-98,, WRANGLER 4 CYL.

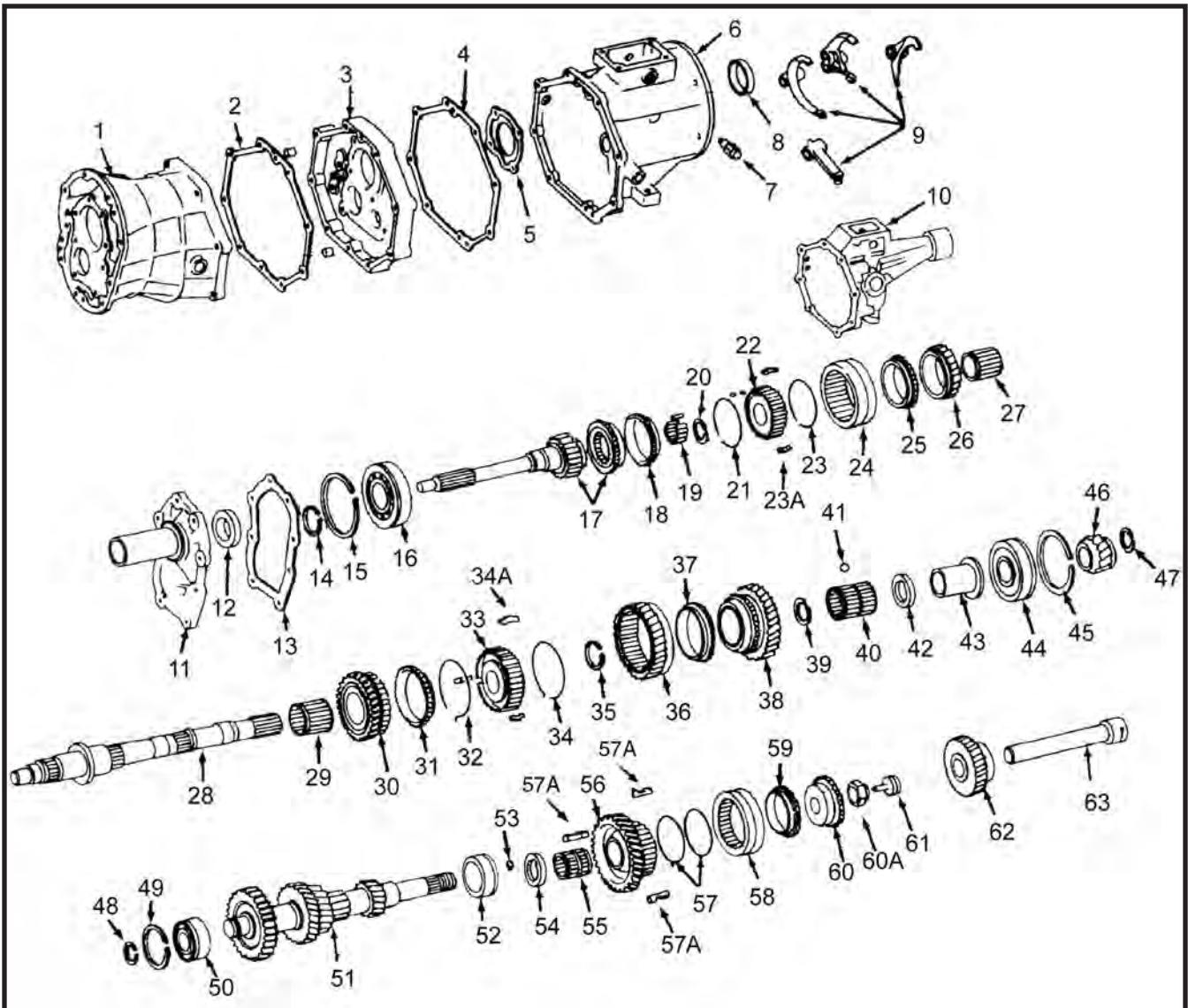

ILL #	MIDWEST #	REF #	REPLACEMENT PART DESCRIPTION
1	83506016		CASE
2	83500506		CASE GASKET
4	83500507		EXTENSION HOUSING GASKET (TO CASE)
5	83500508		RETAINER - M/S REAR BEARING - 1984-87
5	83506034		RETAINER - M/S REAR BEARING - 1988-98
6	83506037		EXTENSION HOUSING 1984-86 ALL, 1987-90 DIESEL, 1998 CHEROKEE
6	83506039		EXTENSION HOUSING 1987-96 GAS - WRANGLER
6	83506038		EXTENSION HOUSING 1991-98 - CHEROKEE, COMANCHE
6	4897133A		EXTENSION HOUSING 1997-98 WRANGLER (OLD# 83502665)
9	4740236		SHIFT FORK KIT 3-4, UPDATE
9	83500527		SHIFT FORK KIT 1-2, UPDATE (REPLACES IRON FORK) w/RAIL
9	83502662		SHIFT FORK 1-2, ALUMINUM
9	4746656		SHIFT FORK 5TH FORK, LATE - ALUMINUM (OLD# 83500637 - (IRON)
10	83506014		ADAPTER 1987-90 GAS - CHEROKEE, COMANCHE, WAGONEER
11	83502685		RETAINER, FRONT INPUT BEARING - 1986

AX5 STYLE (cont.)

ILL #	MIDWEST #	REF #	REPLACEMENT PART DESCRIPTION
11	83503112		RETAINER, FRONT - LATE - NO TUBE - 1987-93 GAS 1994-95 ALL
11	83504108		RETAINER, FRONT 1984-85 - DIESEL
11	83500633		RETAINER, FRONT 1984-85 - GAS
11	83502684		RETAINER, FRONT 1986-87 - DIESEL
12	1981		SEAL - INPUT
14	83500645		SNAP RING
15	83500614		SNAP RING
16	32BCS8-2MT2N		BEARING - INPUT
16	32BC0851NR		BEARING - INPUT - EARLY
17	AX5-16	83500554	INPUT SHAFT - EARLY - 32BC0851NRB THIN BRG -27T, 14 SPLINE, 1984
17	AX5-16A	83502682	INPUT SHAFT - EARLY - B32TM03NX THICK BRG -14 SPLINE, 1985-86
17	AX5-16B	83506020	INPUT SHAFT - LATE - 14 SPLINE, 1987-ON
18/25	TOY-14	83500566	SYNCHRO RING 3-4
19	83502680		NEEDLE BEARING - INPUT POCKET (13 REQ.)
20	83500598		SNAP RING
21/23	83500568		SYNCHRO SPRING 3-4
22	83500562		SYNCHRO HUB - EARLY TO 1987
22	83506027		SYNCHRO HUB - LATE 1988-ON
23A	83506029		3-4 SYNCHRO KEYS
24	83506028		3-4 SLIDER - FORK 1984-96 - ALUMINUM FORK (TO UPDATE, USE 4740236)
24	4740235		SYNCHRO SLEEVE - 3-4 - 1997-ON
26	83500552		3RD GEAR M/S, 1984 -10/4/88
26	83506019		3RD GEAR M/S, 27T - 10/5/88 - 1995
27	83500576		NEEDLE BEARING - 3RD GEAR M/S
28	83502117		MAIN SHAFT 2 W/D, 1984-1998
28	83500559		MAIN SHAFT 4X4, 1984-86
28	83503105		MAIN SHAFT 4X4, 1987-98
29	83506031		NEEDLE BEARING 2ND GEAR 1997-ON
29	83500577		NEEDLE BEARING 2ND GEAR
30	83506018		2ND GEAR M/S 28T - LATE 3.55 O.D. 10/5/88-1998
30	83500551		2ND GEAR M/S 28T - EARLY 3.539 O.D. 10/4/88
31/37	TOY-14A	83500567	SYNCHRO RING 1-2
32/34	83500569		SYNCHRO SPRING 1-2
33	83500561		SYNCHRO HUB 1-2, 1984-98
34A	83500564		SYNCHRO KEYS 1-2
35	83500587		MAIN SHAFT SNAP RING
36	83500555		SYNCHRO SLEEVE 1-2 - M/S REV. GEAR 29T - 1984-97, 1998 WRANGLER
36	4897101AA		SYNCHRO SLEEVE 1-2 - M/S REV. GEAR 1998-ON CHEROKEE
38	83500550		1ST GEAR M/S - 33T - EARLY 1984-10/4/88
38	83506017		1ST GEAR M/S - 33T - LATE 10/5/88-1998
39	83506025		THRUST WASHER, C/S 5TH
40	83500578		NEEDLE BEARING 1ST GEAR - EARLY 1984-87
40	83506031		NEEDLE BEARING 1ST GEAR - LATE 1988-ON
43	83500560		RACE 1ST GEAR NEEDLE BEARING - 1984-87
43	83506026		RACE 1ST GEAR NEEDLE BEARING - 1988-ON
44	30BCS19-2NSLNR		BEARING - M/S REAR - EARLY 1984-87
44	30BCS36-2MT2N		BEARING - M/S REAR - LATE 1988-ON
45	83500613		SNAP RING
46/56	G52-5		5TH GEAR SET 24/47T (INCLUDES 1-83500971, 1-83506022)
46	83500971		5TH GEAR M/S 24T, 1984-98
47	83500587		SNAP RING
48	83500581		FRONT C/S SNAP RING (SMALL)
49	83500612		FRONT C/S SNAP RING (LARGE)

AX5 STYLE (cont.)

ILL #	MIDWEST #	REF #	REPLACEMENT PART DESCRIPTION
51	AX5-8	83500557	CLUSTER GEAR - EARLY 1984-10/4/88 - NUT
51	AX5-8A	83506023	CLUSTER GEAR - LATE 10/5/88-1997, 1998 WRANGLER - SNAP RING
51	4897103AA		CLUSTER GEAR - 1998 CHEROKEE
52	31RUKSS2NRC3	83506033	BEARING, C/S REAR
55	83500644		NEEDLE BEARING, C/S 5TH
56-46	83506022		5TH GEAR C/S 47T, 1984-98
57	83500568		SYNCHRO SPRING 5TH GEAR
57A	83500641		SYNCHRO KEYS 5TH GEAR (3 REQ.)
58	83500642		SYNCHRO SLEEVE 5TH GEAR - 4/6/93 (IRON FORK)
58	4746657		SYNCHRO SLEEVE 5TH GEAR - 4/7/93-ON (ALUMINUM FORK)
59	TOY-14	83500566	SYNCHRO RING 5TH GEAR
60	83506024		SYNCHRO CONE 5TH GEAR SPACER
60A	83500572		NUT, REAR COUNTERSHAFT
62	83500556		REV. IDLER GEAR 29T, 1984-85
62	83503555		REV. IDLER GEAR 1986-1997
62	4897102AA		REV. IDLER GEAR 1998 - UP
63	83500570		SHAFT, REV. IDLER 1984-1997, 1998 WRANGLER
63	4897104AA		SHAFT, REV. IDLER 1998 CHEROKEE
N.I.	83500519		SHIFTER BUSHING

KITS

T160RA	→	BEARING, SEAL AND GASKET KIT w/ 32BC08S1NR INPUT BRG.
T161LR	→	BEARING, SEAL AND GASKET KIT w/ SNAP RING ON C/S
T161R	→	BEARING, GASKET AND SEAL KIT w/ NUT ON C/S
T161RMK	→	BEARING, GASKET AND SEAL KIT - RING AND SMALL PARTS KIT
T161LRMK	→	BEARING, GASKET AND SEAL KIT - RING AND SMALL PARTS KIT
T160RAMK	→	BEARING, GASKET AND SEAL KIT - RING AND SMALL PARTS KIT
SPAX5-50	→	SMALL PARTS KIT
G52-55	→	GASKET KIT

AX15 STYLE
JEEP® CHEROKEE, COMANCHE 1984-98, 6 CYL.
DODGE® DAKOTA, RAM 1992-98

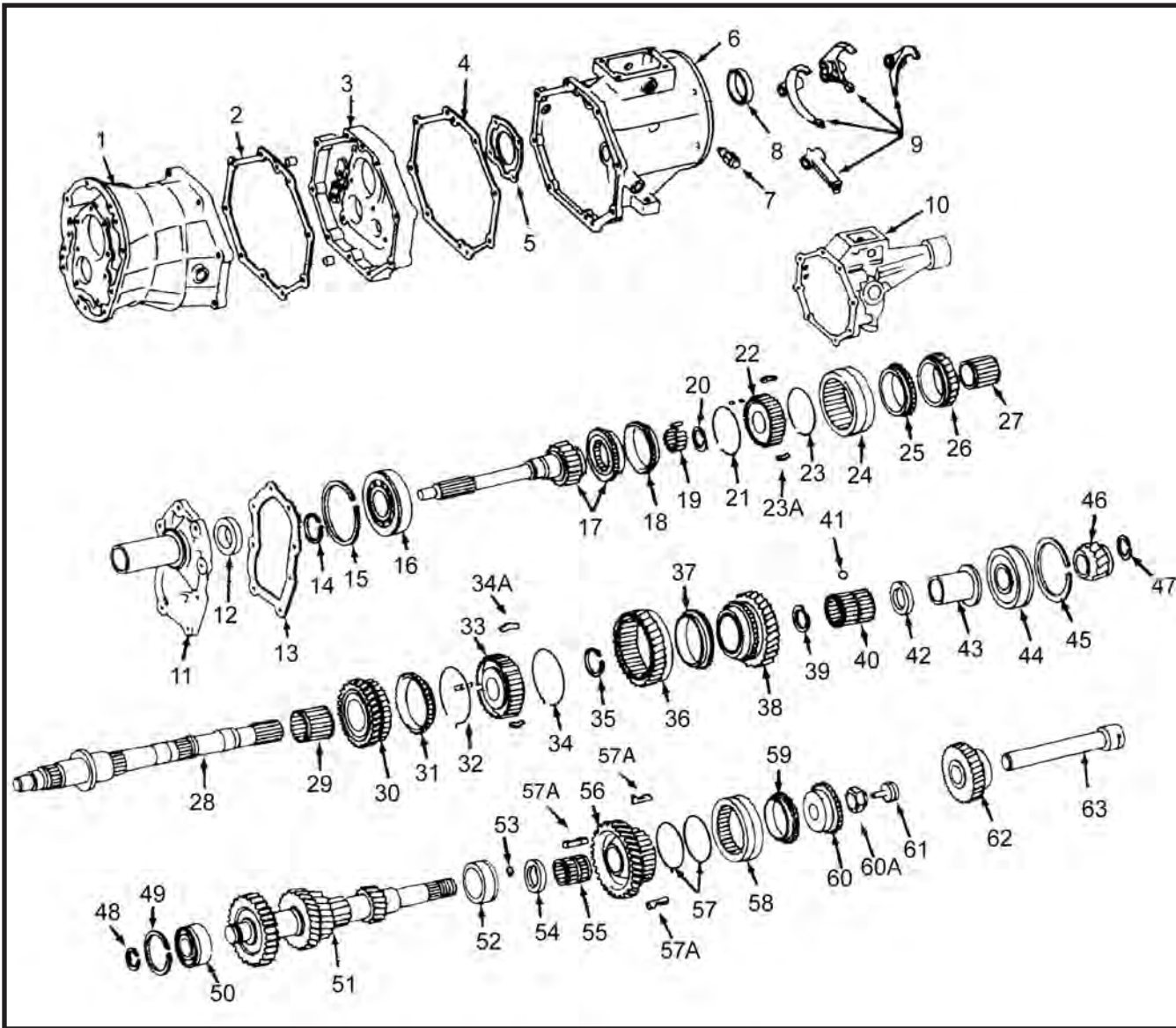

AX15 STYLE (cont.)

ILL #	MIDWEST #	REF #	REPLACEMENT PART DESCRIPTION
N.I.	83503109		PLUG
N.I.	5252075		SPRING
3	5252034		MID-PLATE CASE ASSY
6	VARIOUS (CALL WITH APPLICATION)		REAR CASE - ADAPTER, 1984-99, 6 CYL. JEEP®-1992-97 DODGE®
8	19606		M/S SEAL - 4WD
8	223840		M/S SEAL - 2WD
9	4864224		DEFLECTOR
9	5252056		SHIFT FORK REV.
9	5252057		SHIFT FORK 1-2
9	5252058		SHIFT FORK 3-4
9	5252059		SHIFT FORK 5-REV.
N.I.	5252065		GEARSHIFT SHAFT
N.I.	5252071		SHIFT FORK RAIL #4
N.I.	5252070		SHIFT FORK RAIL #3
N.I.	83500540		PIN - SHIFT FORK
N.I.	5252064		REV. SHIFT HEAD
N.I.	5252037		LEVER - SHIFT SHAFT
N.I.	5252041		HOUSING - SHIFT LEVER
N.I.	34201373		BOLT - SHIFT LEVER
N.I.	83503109		PLUG
N.I.	5252062		SHIFT ARM SHOE
N.I.	5252060		SHIFT ARM - REV.
N.I.	5252063		SHIFT ARM BRACKET - REV.
N.I.	4864222		SHIFT LEVER RETAINER
11	5252052		FRONT BEARING RETAINER 1986-91
11	4636367		FRONT RETAINER 1992-93 WRANGLER - CHEROKEE
11	4636382		FRONT BEARING RETAINER 1992-97 (EXC. ABOVE)
12	223253		INPUT SEAL
14	83506099	83506099	SNAP RING
15	83506222	83506222	SNAP RING
16	40TM05NXC3	83506074	INPUT BEARING
17	AX15-16	5252081	INPUT SHAFT 1986-91, 10 SPL.
17	AX15-16A	4636370	INPUT SHAFT 1992-ON, 10 SPL.
17	4864630		INPUT SHAFT - DODGE®, 14 SPL.
18/25	TOY-14D	83506253	SYNCHRO RING 3-4
19	83506078	83506078	POCKET BEARING - INPUT
20	83506086	83506086	SNAP RING
21/23	84506255		SYNCHRO SPRINGS 3-4, (UP TO SERIAL # 00705123)
	4637534		SYNCHRO SPRINGS 3-4, (AFTER SERIAL # 00705123)
22	83506248	83506248	SYNCHRO HUB 3-4, 1984-98
23A	83506251	83506251	SYNCHRO KEY 3-4
24	83506249	83506249	SYNCHRO SLEEVE 3-4 TO 1997
24	4897050AA	4897050AA	SYNCHRO SLEEVE 3-4 1998-ON
26	5252079	525209	3RD GEAR M/S TO 1997
26	4897047AA		3RD GEAR M/S 1998-ON
27	83506077	83506077	NEEDLE BEARING - 3RD GEAR M/S
28	83506244	83506244	MAIN SHAFT 2WD TO 1997
28	4874288		MAIN SHAFT 2WD 1998-ON
28	4636579		MAIN SHAFT 2WD 1992-97
28	83506243	83506243	MAIN SHAFT 4X4
29	83506076		NEEDLE BEARING 2ND GEAR M/S
30	5252078		2ND GEAR M/S - TO 1984-91 - 33T
30	4636369		2ND GEAR M/S - 1992-ON
31/37	TOY-14C	83506252	SYNCHRO RING 1-2
33	83506247		SYNCHRO HUB 1-2
34	83506254		SYNCHRO SPRING 1-2
34A	83506250		SYNCHRO KEY 1-2
36	5252082		SYNCHRO SLEEVE - REV. GEAR M/S, 1984-98
38	4636368		1ST GEAR M/S, 1993-ON

AX15 STYLE (cont.)

ILL #	MIDWEST #	REF #	REPLACEMENT PART DESCRIPTION
40	83506075		NEEDLE BEARING - 1ST GEAR M/S
41	83500542		BALL - DETENT
N.I.	83500545		SPRING - DETENT
N.I.	83503109		PLUG
N.I.	83500543		PIN - INTERLOCK
N.I.	5252066		SHIFT FORK RAIL #1
N.I.	5252076		SNAP RING - SHIFT FORK
N.I.	5252068		SHIFT FORK RAIL #2
44	35BCS342MT2N	83506073	BEARING M/S REAR
N.I.	AX15-144	5252036	REAR BEARING RETAINER
46	5252083		5TH GEAR M/S - 25T
47	83506268		SNAP RING
48	83506081		SNAP RING
49	83506220		SNAP RING
50	25RT59SN	83506259	BEARING - C/S FRONT
51	AX15-8	5252085	CLUSTER GEAR 43/32/21/13/12 (USES NUT)
51	AX15-8A	4636371	CLUSTER GEAR 43/32/21/13/12 (USES SNAP RING)
52	34RUKS64NRC3	83506080	BEARING, C/S REAR
54	83506245		THRUST WASHER - C/S 5TH GEAR
55	83506079		NEEDLE BEARING - C/S 5TH GEAR
56	AX15-19	4637535	5TH GEAR C/S TO TRANS ID# 00705123
56	4637527		5TH GEAR C/S TRANS ID# 00705124/UP3
57	83506255	83506255	SYNCHRO SPRING - 5TH GEAR
57A	83506256		SYNCHRO KEY - 5TH GEAR (3 REQ.)
57A	4637532		SYNCHRO KEY - 5TH GEAR - UPDATED (3 REQ.)
58	83506257		SYNCHRO SLEEVE - 5TH GEAR
59	TOY-14D	83506253	SYNCHRO RING - 5TH GEAR
59	TOY-14E	4637533	SYNCHRO RING - 5TH GEAR - UPDATED
60	83506242		SYNCHRO CONE - 5TH GEAR
61	84506029		OIL PIPE
62	5252084		REV. IDLER GEAR
63	83506258		REV. IDLER SHAFT

KITS

T163R	→ BEARING, SEAL & GASKET KIT
T163RMK	→ BEARING KIT MASTER REBUILD
T163RAMK	→ BEARING KIT MASTER REBUILD LATE
RKAX15	→ RING KIT 1985-90
RKAX15L	→ RING KIT LATE 1990-ON
TC2030-12	→ T/C ADAPTER GASKET

**Motive
Gear®**

BA10/PEUGEOT STYLE

JEEP® CHEROKEE, COMANCHE 1987-89

WAGONEER 1987 - WRANGLER 1987-89

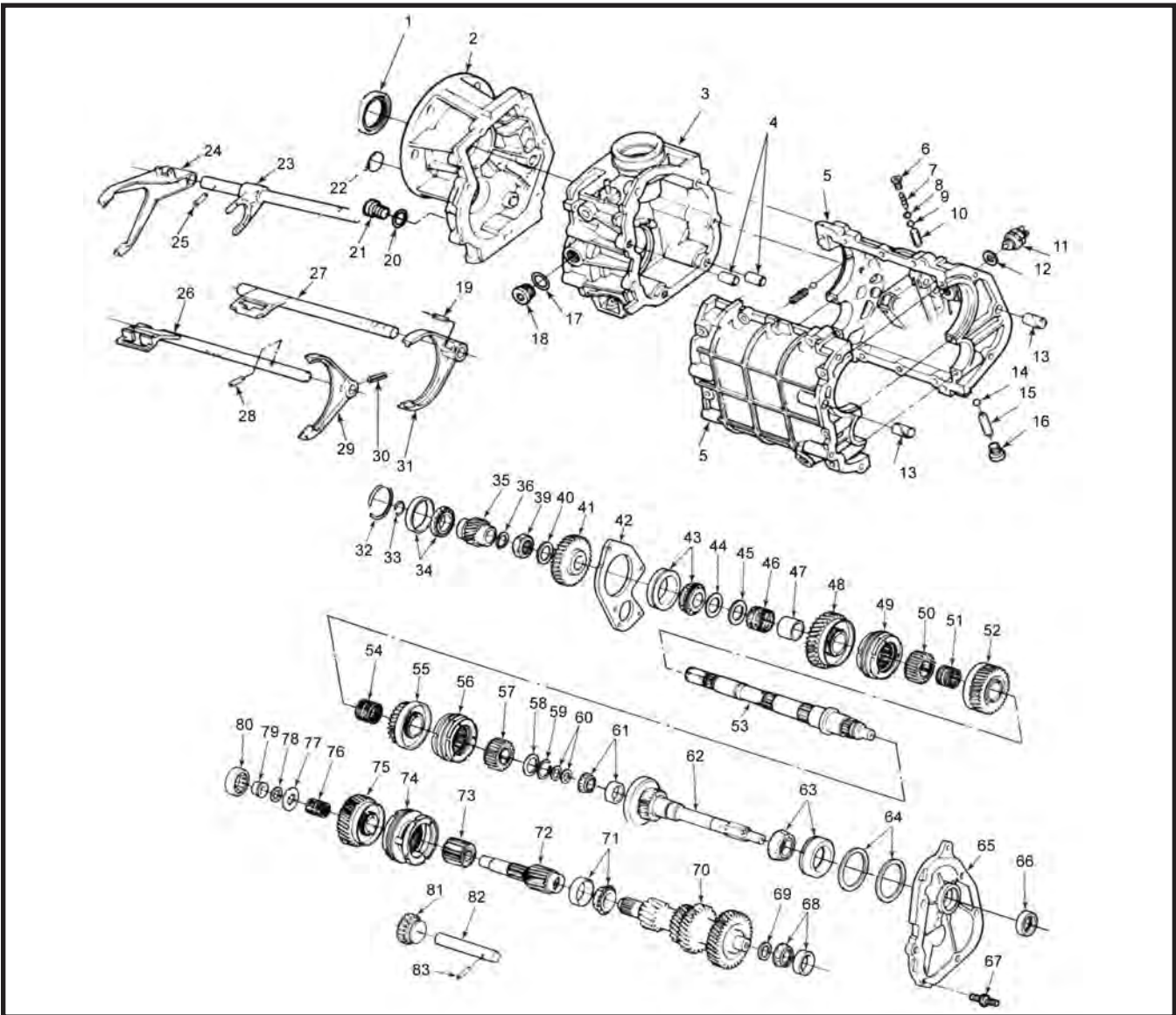

ILL #	MIDWEST #	REF #	REPLACEMENT PART DESCRIPTION
1	14730	83504419	REAR SEAL 4X2
1	19601	83503250	REAR SEAL 4X4
3/2	83505455		EXT. HOUSING-CHEROKEE, COMANCHE, WAGONEER 4x2
3/2	83505210		EXT. HOUSING-CHEROKEE, COMANCHE, WAGONEER 4X4, 1987
3/2	83505454		EXT. HOUSING-CHEROKEE, COMANCHE, WAGONEER 4X4 - 1988-89
3/2	83505209		EXT. HOUSING-WRANGLER - 3 BOLT SHIFTER FLANGE, 1987-89
3/2	83504437		EXT. HOUSING-WRANGLER - w/o 3 BOLT SHIFTER FLANGE
5	83505568		MAIN CASE, 1987-90
22	83504872		EXTENSION HOUSING PLUG
24	83505456		FORK - 5-REV., 1978-90
29	83503263		FORK - 1-2, 1978-90
31	83503268		FORK - 3-4, 1978-90
33	83503224		SNAP RING
34	83503201		M/S REAR ROLLER BEARING
35	BA10-5	83505452	5TH GEAR M/S - 28T

BA10/PEUGEOT STYLE (cont.)

ILL #	MIDWEST #	REF #	REPLACEMENT PART DESCRIPTION
35		83504099	5TH GEAR M/S - 27T
36	83503253		SNAP RING
39	83503204	83503204	NUT - REAR M/S
41	BA10AF	4762679	REV. GEAR SET (MS REV, REV. IDLER)
42	83503233		BEARING RETAINER PLATE
43	83503212		BEARING - M/S COVER
44	83503222		SHIM
45	83504622		SHIM
46	83503231		NEEDLE BEARING - M/S 1ST GEAR
47	83503213		SPACER - 1ST GEAR NEEDLE BEARING
48	BA10-12A	83505444	1ST GEAR M/S 32T - USE WITH BA10-8 C/S
48	83503214		1ST GEAR M/S 34T
49	BA10-80	83504089	SYNCHRO ASSY 1-2
51	83503208		NEEDLE BEARING - M/S 2ND GEAR
52	BA10-21	83503218	2ND GEAR M/S - ALL, 1987-1989
53	83504429		MAIN SHAFT 2WD - 1987-1990
53	BA10-2	83503219	MAIN SHAFT 4WD - ALL
54	83503208		NEEDLE BEARING - M/S 3RD GEAR
55	BA10-11	83503221	3RD GEAR M/S - ALL 1987-1989
56	BA10-2.5	83504103	SYNCHRO ASSY 3-4, 1987-1990 - 28 SPD
58	83503205		SPRING WASHER
59	83503203		SNAP RING
60	83504870		WASHER (2 REQ.)
61	32004	83504410	BEARING - INPUT POCKET
62	BA10-16	83505205	INPUT SHAFT -1988 & 1970 CHEROKEE, COMANCHE & WRANGLER
63	83505447		BEARING - INPUT
64	83503230		SHIM KIT - INPUT
65	83505202		FRONT PLATE - CHEROKEE, COMANCHE, WAGONEER - 1987
65	83505203		FRONT PLATE - WRANGLER THRU 7/17/88
65	83505388		FRONT PLATE - CHEROKEE, COMANCHE 1988-89, WRANGLER TRANS ID# 7/17/89 - UP
66	83503234		SEAL - INPUT
68	EC12250	83503209	BEARING - C/S FRONT - EARLY 1987
68	83504447		BEARING - C/S FRONT - LATE 1988-89
69	83503254		SHIM KIT - C/S FRONT BEARING
70	BA10-8E	83503239	CLUSTER GEAR - EARLY 1 I.D. GROOVE ON 2ND GEAR
70	BA10-8	83505445	CLUSTER GEAR - LATE 1 I.D. GROOVE ON 1-2 GEAR, R37-29-22-12-22
71	EC12589	83503217	BEARING - C/S REAR
72	83503242		5TH GEAR SHAFT
74	BA10-2.5B	83503246	SYNCHRO ASSY 5TH GEAR
75	83503243		5TH GEAR C/S - 27T
75	83505451		5TH GEAR C/S - 28T
76	83503207		NEEDLE BEARING - C/S 5TH GEAR
77	83503247		SPACER SHIM
78	83503237		SHIM KIT
80	83503201		BEARING - C/S REAR
81	BA10AF	83504500	REVERSE GEAR SET (M/S REV, REV. IDLER)
82	83503262		SHAFT - REV. IDLER GEAR

KITS

T219R

→ BEARING, SEAL AND GASKET KIT

T5 NON-W/C STYLE

FORD®, MUSTANG, THUNDERBIRD 1982-87
CAMARO, FIREBIRD, S10, ASTRO 1982-87 - JEEP® 1982-86

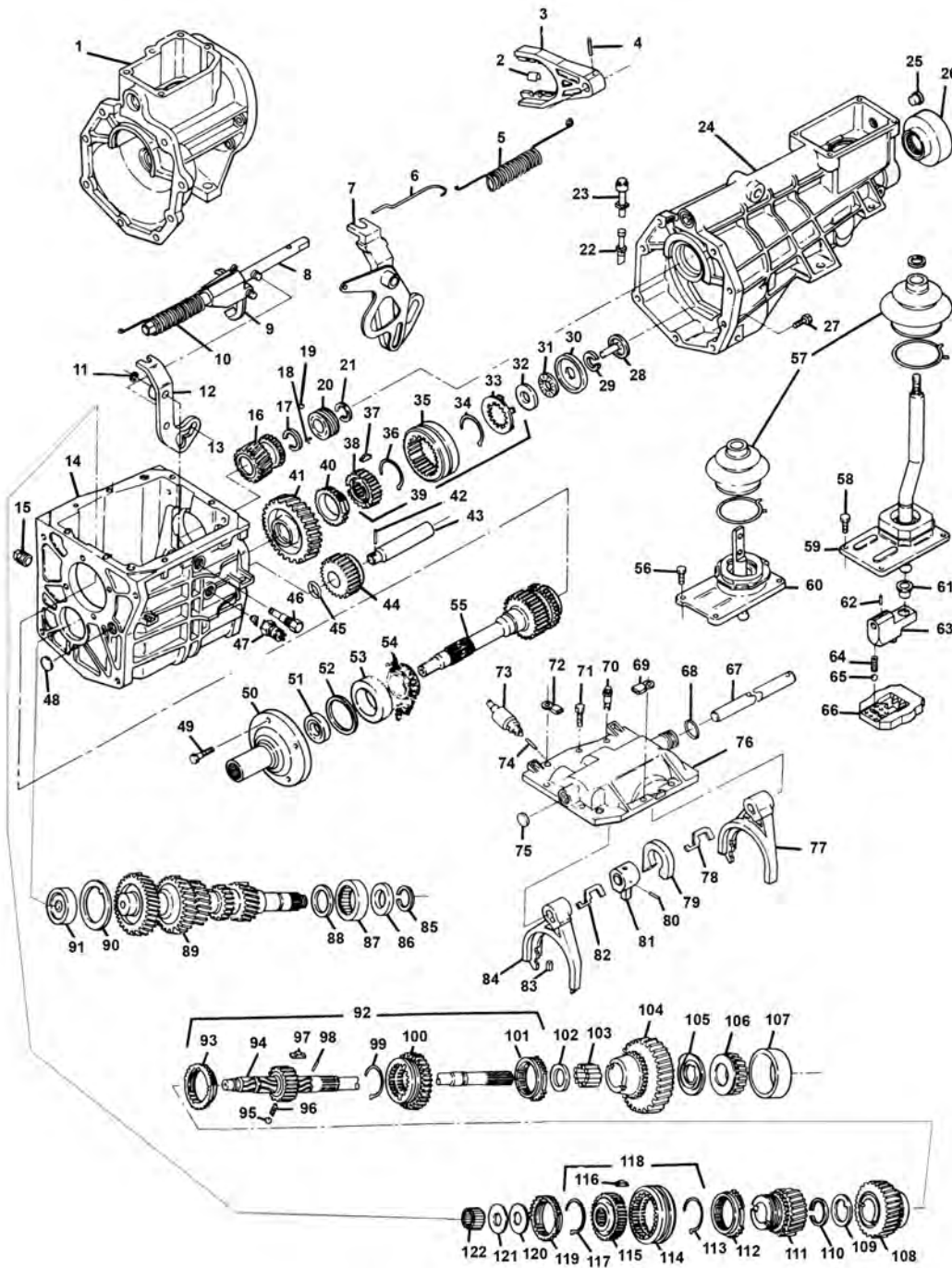

ILL #	MIDWEST #	REF #	REPLACEMENT PART DESCRIPTION
2	1352127008	D8ZZ7L082A	FORK PADS
3	1352096014		5TH SHIFT FORK
4	1000043001		ROLL PIN
5	1352156089		SPRING
6	1352156008	8134077	SPRING, HOOK
7	1352098003	E3ZZ7K002A	LEVER, REV. FORK
8	1352600002		5TH RAIL, PIN, ROLLER
9	1352096005		FORK, REV.
10	1352156005	E3ZZ7K205A	SPRING
12	1352098003	E3ZZ7K002A	SHIFT LEVER 5-REV. - CAN USE 1352098007

T5 NON-W/C STYLE (cont.)

ILL #	MIDWEST #	REF #	REPLACEMENT PART DESCRIPTION
14	1352565002	E3ZZ7005B	MAIN CASE - JEEP*
14	1352565013	15536219	MAIN CASE - S-10, ASTRO 4 CYL.
14	1352565015	15546826	MAIN CASE - S-10, ASTRO 2.8 V6
14	1356565016		MAIN CASE - CAMARO/FIREBIRD
15	1300052008		PLUG DRAIN
16	1352070004	8134081	5TH GEAR M/S - 25T - NISSAN*, JEEP, EAGLE
16	1352070009	14071843	5TH GEAR M/S - 27T - GM*
16	1352070010	E3ZZ7K316B	5TH GEAR M/S - 25T - FORD*
16	1352070014	14083538	5TH GEAR M/S - 23T - CAMARO, S-10
16	1352070015	14091341	5TH GEAR M/S - 25T - CAMARO, S-10, ASTRO VAN
16	1352070018	14083539	5TH GEAR M/S - 29T - NISSAN 300ZX
16	1352070024		5TH GEAR M/S - 23T - JEEP 1982-86
16	1352070026	100049010	5TH GEAR M/S - 25T - CHEVETTE
16	1352070028	100048981	5TH GEAR M/S - 23T - S-10, CAMARO V6
16	1352070029	100048982	5TH GEAR M/S - 25T - S-10, ASTRO VAN 4 CYL.
16	1352070032		5TH GEAR M/S - 25T - 1987 CAMARO V8
16	1352070036		5TH GEAR M/S - 29T - NISSAN 300ZX, TURBO 1986 (TAG# 151)
16	1352070041		5TH GEAR M/S - 27T - ASTRO VAN 4.3 V6
16	1352070047		5TH GEAR M/S - 31T - CAMARO 1987 V8
18	1390056002	E3ZZ17B3366A	CLIP - SPEEDO GEAR
19	1000109001		BALL - SPEEDO GEAR
20	1351110002	14071731	SPEEDO GEAR 7T - PURPLE
20	1352110002		SPEEDO GEAR 7T - NATURAL
20	1352110003	14053347	SPEEDO GEAR 9T - RED
20	1352110004	E3ZZ17285B	SPEEDO GEAR 6T - BLACK
20	1352110005	E3ZZ17285A	SPEEDO GEAR 7T - YELLOW
20	1352110008		SPEEDO GEAR 7T - ORANGE
20	1352110009	15546631	SPEEDO GEAR 40T - STEEL
20	1352110011	FOZZ17285A	SPEEDO GEAR 8T - AQUA
21/17	1000132032		SNAP RING
22	T94-95		BREATHER ASSY - ALL (EXC. BELOW)
23	1000572002		VENT -O-RING ASSY - ASTRO VAN
24	1352566052		EXTENSION ASSY - ASTRO VAN TO 1988
24	1352566063	15546959	EXTENSION ASSY - ASTRO VAN 1989-ON
24	1352566059	15546832	EXTENSION ASSY - S-10 2WD
24	1352566057	15581569	EXTENSION ASSY - S-10 4WD
24	1352566026	14083545	EXTENSION ASSY - CAMARO/FIREBIRD TO 1987 - CAN USE 1352566076
24	1352566045		EXTENSION ASSY - CAMARO/FIREBIRD - 1988-ON
24	1352566079		EXTENSION ASSY - FORD
24	1352566065	15547208	EXTENSION ASSY - S-10 2WD (ELEC. SPEEDO)
25	1300052008		CUP PLUG
26	9613S		REAR SEAL - GM
26	7692S		REAR SEAL - FORD
26	472439		REAR SEAL - JEEP
27	1300183014	8134098	BOLT
28	1352034001	E5ZZ7L275A	OILING FUNNEL
29	1300139001		SNAP RING
30	1352018001	8134088	THRUST RACE
31	1351132001	8134034	THRUST BEARING - CAN USE TC1423
32	1352018001	8134088	THRUST RACE
33	1352040001	E3ZZ7C396A	RETAINER
36/34	1332156002	D4ZZ7109A	SYNCHRO SPRING 5-REV.
37	1332093002	D4ZZ7A044A	SYNCHRO KEY 5-REV.
39	1352590001	E3ZZ7124B	5-REV. SYNCHRO ASSY
40	1332091002R		SYNCHRO RING, 5TH
41	1352080056		5TH GEAR C/S 53T, JEEP, S-10
41	1352080065	E3ZZ7144B	5TH GEAR C/S 51T, JEEP, S-10
41	1352080066	15546852	5TH GEAR C/S 59T, CHEVY ASTRO VAN
41	1352080067	15546831	5TH GEAR C/S 61T, CHEVY S-10, ASTRO VAN
41	1352080024		5TH GEAR C/S 55T, NISSAN
41	1352080107	E3ZZ7144A	5TH GEAR C/S 55T, CHEVY CAMARO 1984-V8
41	1352080108	10048985	5TH GEAR C/S 53T, CHEVY CAMARO - V6
41	1352080109		5TH GEAR C/S 51T - CAN USE 1352080065
42	1000043016	8134040	RACE PIN
43	1351068001	E3ZZ7140A	SHAFT, REV. IDLER

T5 NON-W/C STYLE (cont.)

ILL #	MIDWEST #	REF #	REPLACEMENT PART DESCRIPTION
44	1352584007R		REVERSE IDLER GEAR
45	1000141211		O-RING
46	1352183002	E7TZ7K024A	PIVOT PIN
47	1332140005	E0ZZ15520A	BACK UP LIGHT SWITCH - JEEP*, FORD*
47	1000140005		BACK UP LIGHT SWITCH - GM*
47	1000140014	E6TZ7288A	BACK UP LIGHT SWITCH - NISSAN*
49	1300183009		BOLT
50	1351027001R		BEARING RETAINER - JEEP (CAST IRON)
50	1352027001		BEARING RETAINER - NISSAN 280Z
50	1352027003R		BEARING RETAINER - S-10, ISUZU* TO 1992
50	1352027007	14069863	BEARING RETAINER - CAMARO, ASTRO VAN, ISUZU 1993-ON
50	1352027008R		BEARING RETAINER - MUSTANG V8, IRON - CAN USE 527-004
50	1352027009		BEARING RETAINER - NISSAN 300ZX
50	1352527004R		BEARING RETAINER - MUSTANG V8, STEEL TUBE - ALUMINUM BASE - CAN USE 027-008
51	7412S		SEAL, INPUT
52	T4-45AX	1351037001 THRU 1351037028	SHIM, INPUT - SELECTIVE - VARIOUS THICKNESS
53	LM48510		BEARING RACE INPUT - CAN USE A5
54	LM48548		BEARING RACE INPUT - CAN USE A5
55	1351085008R	83500975	INPUT SHAFT, JEEP 21T, 10 SPLINES, 9.328" O.A.
55	1351085010	83500968	INPUT SHAFT, JEEP 21T, 14 SPLINES, 9.328" O.A.
55	1352085002		INPUT SHAFT - CHEVETTE 21T, 14 SPLINES, 8-3/4" O.A.
55	1352085003R		INPUT SHAFT - S-10, 9 -1/4", 21T, 14 SPLINES, 9.296" O.A.
55	1352085004		INPUT SHAFT - S-10, 4 CYL. 8-7/8", 21T, 14 SPLINES
55	1352085008		INPUT SHAFT - NISSAN 280ZX, 22T, 24 SPLINES, 9.328" O.A.
55	1352085010R	14083546	INPUT SHAFT - CAMARO 1983-87 V8,24T, 26 SPLINES, 8-3/4" O.A.
55	1352085011	E3ZZ7017A	INPUT SHAFT - MUSTANG, 24T, 10 SPLINES, 9-1/4" O.A.
55	1352085012R	14083542	INPUT SHAFT - CAMARO, ASTRO, 21T, 14 SPLINES, 8.75" O.A.
55	1352085013		INPUT SHAFT - NISSAN 300ZX, 24T, 24 SPLINES
55	1352085040R		INPUT SHAFT - CAMARO, ASTRO, 22T, 14 SPLINES, 8.75" O.A.
57	1386021001		SHIFT BOOT - CONTROL LEVER - ALL (EXC. BELOW)
57	1352021005		SHIFT BOOT - CONTROL LEVER - ASTRO VAN
58/56	1351183001	E3ZZ7A443A	SCREW
59	1351598015	8134063	CONTROL LEVER - JEEP
60	1351598020		CONTROL LEVER - JEEP (085 ONLY) - CAN USE 1352598099
60	1352598072		CONTROL LEVER - CAMARO
60	1352598085	15618611	CONTROL LEVER - ASTRO VAN - CAN USE 1352598049
60	1352598086	15618975	CONTROL LEVER - S-TRUCK
60	1352598113		CONTROL LEVER - BEIJING JEEP (223, 241)
61	1352127009	E3ZZ7K453A	SHIFTER BUSHING
62	1000043016	8134040	ROLL PIN
63	1351098005	8134054	OFFSET LEVER - SHORT
63	1351098006	E3ZZ7F018A	OFFSET LEVER - LONG
64	1351156001	E3ZZ7234B	SPRING
65	1300109003	453593	BALL
66	1352014005		GUIDE PLATE - SHIFT
67	1352100011	15546819	SHIFT RAIL - JEEP, S-10
67	1352100014	15529613	SHIFT RAIL - ASTRO VAN
67	1352100016	10117841	SHIFT RAIL - CAMARO/FIREBIRD - CAN USE 1351100003
68	1332141001	8127471	O-RING
70	1332183006		ALIGNMENT BOLT
71	1332183009	8134047	BOLT
72/69	1352056003		WIRE CLIP
73	1300140004	E6ZZ7A247A	NEUTRAL SAFETY SWITCH - FORD
73	1000140009		NEUTRAL SAFETY SWITCH - GM, JEEP
74	1000043020	E5ZZ7C031A	PIN
75/48	103892		PLUG
76	1353097001		SHIFT COVER - JEEP*, S-10
76	1352097010	E5ZZ7222A	SHIFT COVER - NISSAN*
76	1352097016		SHIFT COVER - CAMARO/FIREBIRD, ASTRO VAN
77	1352096002	E3ZZ7230B	SHIFT FORK 1-2
79	1352014004	E3ZZ7K201A	INTERLOCK PLATE
80	1332043004	8128387	PIN - SELECTOR ASSY
81	1352596003	D4ZZ7302A	SELECTOR ARM ASSY
82/78	1352190003		SELECTOR PLATE

T5 NON-W/C STYLE (cont.)

ILL #	MIDWEST #	REF #	REPLACEMENT PART DESCRIPTION
83	1352127008	D8ZZ7L082A	FORK PADS
84	1352096004	E3ZZ7230C	SHIFT FORK 3-4
85	1352139002	E3ZZ7026A	SNAP RING
86	1352053001	E3ZZ7149A	SPACER
87	FC66263	1351134001	ROLLER BEARING, C/S REAR
88	1351053001	E3ZZ7125A	SPACER, C/S BEARING
89	1352077005	14069888	CLUSTER GEAR - CAMARO 35-34-23-15-15, 1983, 4 CYL., V6
89	1352077016		CLUSTER GEAR - ASTRO 37-31-25-15--15, 4 CYL.
89	1352077060R		CLUSTER GEAR - CAMARO 31-29-22-15-15-14 1983-87 V8, MUSTANG 1983-84
89	1352077062R		CLUSTER GEAR - S-10, JEEP, CAMARO 37-32-23-15-15-14-26
89	1352077063R	15615674	CLUSTER GEAR - CAMARO, S-10 4 CYL. 37-31-25-15-15
89	1352077064		CLUSTER GEAR - ASTRO 4.3 V6, NISSAN, CAMARO 35-31-23-15-15
90	1351193001	8134032	THRUST WASHER
91	DK55836	1352134002	BEARING, C/S FRONT
92	1352671074	10049011	MAIN SHAFT ASSY - CHEVETTE 20 1/4"
92	1352671076	83501166	MAIN SHAFT ASSY - JEEP 14-3/4" w/o 1ST GEAR, NEEDLE BEARING
92	1352671080		MAIN SHAFT ASSY - JEEP 14-3/4" - 1ST GEAR, NEEDLE BEARING
92	1352671082		MAIN SHAFT ASSY - NISSAN 280ZX, 300ZX
92	1352671084	E3ZZ7061A	MAIN SHAFT ASSY - FORD* MUSTANG 24" - 1983-84
92	1352671088	10104448	MAIN SHAFT ASSY - CAMARO/FIREBIRD 24-3/4"
92	1352671096	15616186	MAIN SHAFT ASSY - CHEVY S-10 2WD, 24-1/8" (MECH. SPEEDO)
92	1352671097	15616187	MAIN SHAFT ASSY - CHEVY S-10, 4X4 19"
92	1352671099	15615680	MAIN SHAFT ASSY - CHEVY ASTRO (ELEC. SPEEDO)
92	1352671100	15615679	MAIN SHAFT ASSY - CHEVY S-10 2WD, 24-1/8", LATE (ELEC. SPEEDO)
95	1000109001		BALL - SPEEDO
96	1351156015	E3ZZ7234A	SPRING
97	1352093002	8127401	SYNCHRO KEY 1-2
98	1332043001	8124227	PIN, THRUST WASHER
99	1352156018	E5ZZ7109A	SYNCHRO SPRING 1-2
100	1352070044		SYNCHRO SLEEVE 1-2 M/S REV.
101/93	1332091003R		SYNCHRO RING 1-2
102	1000018011	83500962	THRUST WASHER, 1ST GEAR
103	1000132046	83500969	NEEDLE BEARING, 1ST GEAR
104	1352080119		1ST GEAR M/S - 32T - 4 CYL. S-10, CAMARO, CHEVETTE (4.37" O.D.)
104	1352080122		1ST GEAR M/S - 34T - NISSAN 300ZX
104	1352080123	15585193	1ST GEAR M/S - 32T - VARIOUS (4.43 O.D.) JEEP w/o NEEDLES-1ST GEAR
104	1352080124	15585194	1ST GEAR M/S - 33T - ASTRO VAN 4.3 V6
104	1352080125		1ST GEAR M/S - 32T - JEEP USES NEEDLE BEARING
105	1338193003	E3ZZ7071A	THRUST WASHER - M/S 1ST
106	25877		BEARING CONE - M/S REAR
107	25821		BEARING RACE - M/S REAR
108	1352080126	E3ZZ7102B	2ND GEAR M/S - 31T - CHEVY S-10, ASTRO 4 CYL., 2.8 V6, JEEP - EARLY - FORD (3.1" O.D.)
108	1352080127	15585187	2ND GEAR M/S - 31T - CHEVETTE, S-10 ASTRO 4 CYL. 2.8 V6, (3.6" O.D.)
108	1352080129		2ND GEAR M/S - 32T - NISSAN* 280, 300ZX 1984-85
108	1352080130		2ND GEAR M/S - 32T - NISSAN 300ZX, 1985-86
108	1352080131	10081943	2ND GEAR M/S - 33T - CHEVY CAMARO V8 - 1984-87
108	1352080132	15585188	2ND GEAR M/S - 31T - CHEVY CAMARO 2.8 V6, ASTRO 4.3 V6
109	1332193001	D4ZZ7119A	THRUST WASHER
110	1332139002	D4ZZ7064A	SNAP RING
111	1352080011		3RD GEAR M/S - 29T - 1982-83 S-10, 1983 CAMARO, 1982-83 JEEP* CAN USE 1352410010 TO UPDATE
111	1352080015		3RD GEAR M/S - 27T - ASTRO VAN 4.3, NISSAN 280Z, 3.093" O.D.
111	1352080016R		3RD GEAR M/S - 30T - V8 CAMARO 1983-87, FORD 1983-84
111	1352080017R	E3ZZ7B340D	3RD GEAR M/S - 27T - CHEVY S-10 1984-ON, JEEP* 1984-ON, ASTRO VAN 4 CYL., CAMARO 4 CYL. V6 1983-87
111	1352080021		3RD GEAR M/S - 27T - NISSAN* 280Z, 300Z, 1984-85
111	1352080025	14083540	3RD GEAR M/S - 25T - CHEVY ASTRO VAN, S-10, 4 CYL., 2.8 V6, CAMARO
111	1352080041		3RD GEAR M/S 27T - NISSAN 300ZX 1985-86
114	T5-15XX		SYNCHRO SLEEVE
115	N.S.S.		SYNCHRO HUB, N.S.S.
116	1351093001	E4ZZ7A044A	KEY, SYNCHRO 3-4
117/113	1352156018	E5ZZ7109A	SPRING, SYNCHRONIZER 3-4
118	1352590011	15635335	SYNCHRO ASSY 3-4 w/o RINGS
118	1352590012		SYNCHRO ASSY 3-4 - RINGS
119/112	1351091001R		SYNCHRO RING 3-4
120	1352018005		THRUST RACE

T5 NON-W/C STYLE (cont.)

ILL #	MIDWEST #	REF #	REPLACEMENT PART DESCRIPTION
121	1351132004	8134018	THRUST BEARING
122	QBR23549	1332131001	NEEDLE BEARING, POCKET (15 REQ.)

KITS

T5R	→ BEARING, GASKET & SEAL KIT
T5RS	→ BEARING KIT - SMALL PARTS
T5RMK	→ BEARING KIT - SMALL PARTS, RINGS, FORK PADS
RK5	→ SYNCHRO RING KIT
1352410010	→ GEAR KIT - S-10, JEEP UPDATE - 007062, 080017
SP5-50	→ SMALL PARTS KIT
K5	→ GASKET & SEAL KIT

T5 W/C STYLE

FORD® MUSTANG, THUNDERBIRD 1985-98

S10, CAMARO, FIREBIRD 1988-98

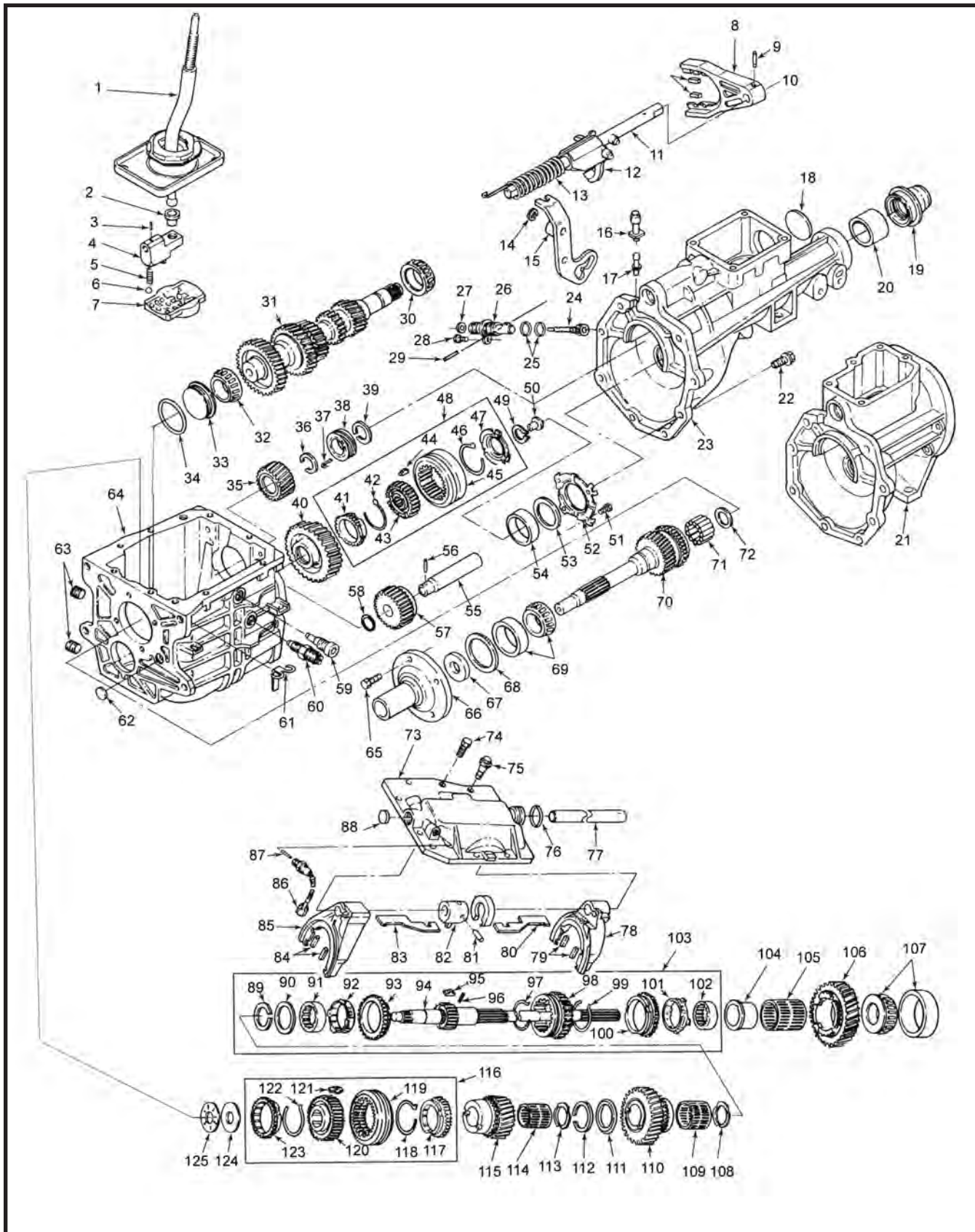

T5 W/C STYLE (cont.)

ILL #	MIDWEST #	REF #	REPLACEMENT PART DESCRIPTION
1	1352598095		CONTROL LEVER/HOUSING - CAMARO, FIREBIRD
1	1352598087		CONTROL LEVER/HOUSING - MUSTANG
1	1352598098		CONTROL LEVER/HOUSING - S10
2	1352127009	E3ZZ7K453A	SLEEVE - SHIFTER BALL
3	1000043016	8134040	ROLL PIN
4	1351098005	8134054	OFFSET LEVER - SHORT (GM')
4	1351098006	E3ZZ7F018A	OFFSET LEVER - LONG (FORD')
5	1351156001	E3ZZ7234B	SPRING
6	1300109003	453593	BALL
7	1352014005		DETENT GUIDE PLATE
8	1352096014	E3ZZ7230D	FORK 5TH - ALL
9	1000043016	8134040	ROLL PIN
11	1352600002		SHIFT RAIL ASSY
12	1352596009	E3ZZ7231A	SHIFT FORK REV.
12	1352596013		SHIFT FORK REV. - REV. BRAKE
13	1352156005	E3ZZ7K205A	SPRING
14	1332139003	8127469	SNAP RING
15	1352098003	E3ZZ7K002A	SHIFT LEVER 5-REV.
15	1352098011		SHIFT LEVER 5-REV. - REV. BRAKE
16	1352572003		BREATHER
17	T94-95		BREATHER, NON W/C
18	1000113010	E3ZZ7K381A	PLUG
19	7692S	D6AZ7052A	SEAL - FORD* MUSTANG V8 4 CYL.
19	9613S		SEAL - CAMARO, FIREBIRD, S10 2WD
20	1000127017		BUSHING - FORD
20	6260048		BUSHING - GM'
21	1352566074		EXT HOUSING ASSY - BUSHING - CAMARO - (MECH. SPEEDO)
22	1300183014	8134098	BOLT
23	1352566081		EXT HOUSING ASSY - BUSHING - FORD T-BIRD, COUGAR, MUSTANG
23	1352566085		EXT HOUSING ASSY - BUSHING - ISUZU*
23	1352566086		EXT HOUSING ASSY - BUSHING - S10 P/U - (ELEC. SPEEDO)
31	1352077048	E7ZZ7113A	CLUSTER GEAR - FORD MUSTANG, T-BIRD - 4 CYL. TURBO 33-31-23-15-14
31	1352077054		CLUSTER GEAR - CHEVY S10 4.03 TO 1, MUSTANG, 37-32-23-15-14
31	1352077052R	E5ZZ7113C	CLUSTER GEAR - MUSTANG 3.35 TO 1, 34-31-23-15-15
31	1352077056		CLUSTER GEAR - ISUZU* , S10 V6 (1993-95), 37-31-25-15-15
31	1352077067		CLUSTER GEAR - CHEVY CAMARO 1994, V6, 43-34-28-15-15
31	1352077068R	E9ZZ7113A	CLUSTER GEAR - MUSTANG 3.35 TO 1, HI-PERF, 1990-ON, 34-29-23-15-15
31	1352077070R		CLUSTER GEAR - CAMARO, MUSTANG, V8, 2.95 TO 1, 31-29-22-15-14
30/32	LM67048		BEARING - C/S FRONT & REAR
33	LM67010BCE	1352633001	BEARING RACE - C/S FRONT
34	1000141471	E5ZZ7693A	O-RING
35	1352070022	E3ZZ7K316A	5TH GEAR M/S MUSTANG, T-BIRD 27T
35	1352070027	E5ZZ7K316B	5TH GEAR M/S MUSTANG, S10 25T
35	1352070028	10048981	5TH GEAR M/S CAMARO, FIREBIRD, 2.8 V6, 3.4 V6, 23T
35	1352070029	10048982	5TH GEAR M/S ISUZU, 25T (1352-234)
35	1352070031		5TH GEAR M/S ISUZU, RODEO, 27T
35	1352070032		5TH GEAR M/S CAMARO, FIREBIRD V8 - .63 O.D. 25T
35	1352070043	USE 1352070047	5TH GEAR M/S CAMARO, FIREBIRD V8 - .73 O.D. 31T
35	1352070046	E5ZZ7B320A	5TH GEAR M/S MUSTANG, MOTORSPORT .80 O.D. 33T
35	1352070047		5TH GEAR M/S CAMARO, FIREBIRD V8 .73 O.D. 31T
35	1352070026	10049010	5TH GEAR M/S S10 4 CYL. - 25T
36	1000139032	E3ZZ7064A	SNAP RING
37	1390056002	E3ZZ17B3366A	SPEEDO GEAR CLIP
38	1351110002	14071731	SPEEDO GEAR PURPLE 7T
38	1352110002		SPEEDO GEAR NATURAL 7T
38	1352110003	14053347	SPEEDO GEAR RED 9T
38	1352110004	E3ZZ17285B	SPEEDO GEAR BLACK 6T
38	1352110005	E3ZZ17285A	SPEEDO GEAR YELLOW 7T
38	1352110008		SPEEDO GEAR ORANGE 7T
38	1352110009	15546631	SPEEDO GEAR STEEL 27T

T5 W/C STYLE (cont.)

ILL #	MIDWEST #	REF #	REPLACEMENT PART DESCRIPTION
38	1352110011	F0ZZ17285A	SPEEDO GEAR AQUA 8T
39	1000139032	E3ZZ7064A	SNAP RING
40	1352080029	10117836	5TH GEAR C/S CAMARO, FIREBIRD V6 - 53T
40	1352080051	E5ZZ7144A	5TH GEAR C/S CAMARO, FIREBIRD, MUSTANG 2.95, 1ST, .63 O.D. 51T
40	1352080052	10117838	5TH GEAR C/S CAMARO, FIREBIRD, V8, .73 O.D., 55T
40	1352080074		5TH GEAR C/S MUSTANG, S10 - 53T
40	1352080114	E7ZZ7144A	5TH GEAR C/S MUSTANG, 3.35 1ST, .68 O.D., ISUZU' , 59T
40	1352080162		5TH GEAR C/S, 61T
41	1332091002R		SYNCHRO RING 5TH
44	1332093002	E4ZZ7A044A	SYNCHRO KEYS (3 REQ.)
44	1351093001		3-4 SYNCHRO KEYS (w/RINGS)
46/42	1332156002	D4ZZ7109A	SYNCHRO SPRING (2 REQ.)
47	1352040004		SYNCHRO RETAINER
48	1352590003	E5ZZ7124B	SYNCHRO ASSY 5TH
48	1352590020		SYNCHRO ASSY 5TH, REV. BRAKE
49	1300139001		SNAP RING
50	1352034002	E5ZZ7L275A	OIL FUNNEL
51	1300183002	E5ZZ7C210A	BOLT
52	1352027015		RETAINER - C/S REAR BEARING
53	1352037034 THRU 1352037069		SHIM - C/S REAR BEARING (VARIOUS THICKNESS)
54	LM67010		RACE - C/S REAR BEARING
55	1351068001	E3ZZ7140A	SHAFT - REV. IDLER
56	1000143016		ROLL PIN 3/16 X 1
57	1352584007R	E3ZZ7141A	REV. IDLER GEAR - ALL - 20+
58	1000141211		O-RING
59	1352183002	E7TZ7K024A	PIVOT PIN - SHIFT LEVER
60	1332140005	E0ZZ15520A	SWITCH - BACK-UP LIGHTS
61	1352056003		WIRE CLIP
62	103892		WELCH PLUG
63	1300052007		DRAIN/FILL PLUG
64	1352565014		MAIN CASE/MAGNET ASSY - CAMARO TO 1992, CAST 1352065914
64	1352565017		MAIN CASE/MAGNET ASSY - S10, CAST 1352065914
64	1352565021		MAIN CASE/MAGNET ASSY - MUSTANG, ISUZU' CAST 1352065921 - REVERSE BRAKE
64	1352565022		MAIN CASE/MAGNET ASSY - CAMARO - 1993-ON
64	1352565023		MAIN CASE/MAGNET ASSY - MUSTANG, FORD' MOTORSPORT, S10 w/o REVERSE BRAKE
65	1300183009		BOLT
66	1352027008R	E3ZZ7050A	FRONT BEARING RETAINER - 1986-93 MUSTANG - ALL IRON
66	1352527004		FRONT BEARING RETAINER - 1986-93 MUSTANG ALUMINUM BASE - STEEL TUBE - SEAL
66	1352527003		FRONT BEARING RETAINER - 1994-UP MUSTANG
66	1352027003		FRONT BEARING RETAINER - CHEVY S10 - ALL
66	1352027007	14069863	FRONT BEARING RETAINER - CHEVY CAMARO,PONTIAC', FIREBIRD, ISUZU'
66	1352027019	E7ZZ7050A	FRONT BEARING RETAINER - FORD' MUSTANG, T-BIRD 4 CYL., TURBO
66	1352027030		FRONT BEARING RETAINER - LATE CAMARO (FLAT)
66	13520	27030	LATE STYLE RETAINER - CAMARO (FLAT)
66	1352527001	USE 1352527004	FRONT BEARING RETAINER - FORD MUSTANG - 1994-ON
67	7412S		SEAL - INPUT OIL
68	T4-45AX	1351037001 THRU 1351037028	SHIM - INPUT BEARING (VARIOUS THICKNESS) (T4-45AX)
69	A5		INPUT BEARING - LM48510/LM48548
70	1352085019		INPUT CAMARO, FIREBIRD V8 24T 2.95 TO 1, 8.75 O.A.
70	1352085020R		INPUT FORD MUSTANG, 2.95 TO 1, 24T, NEEDLE POCKET BRG, 9.300" O.A.
70	1352085025R	E5ZZ7017B	INPUT FORD' MUSTANG 3.35 TO 1, 23T - 1986-93, FORD MUSTANG 3.35 TO 1, 23T, 1986-93 - 9.306" O.A. (V8)
70	1352085026		INPUT FORD MUSTANG 3.50 TO 1, 4 CYL. TURBO, 22T, 9.5"
70	1352085038	E7ZZ7017A	INPUT FORD T-BIRD 4 CYL. TURBO, MUSTANG 4 CYL., 3.97 TO 1, 19T, 9.546" O.A.
70	1352085043	10140513	INPUT CAMARO,FIREBIRD V6 2.8, 21T- 1986-92, 4.03 TO 1, 9.269" O.A.
70	1352085045		INPUT S10 4 CYL. ISUZU, RODEO, 21T, 9.273" O.A.

T5 W/C STYLE (cont.)

ILL #	MIDWEST #	REF #	REPLACEMENT PART DESCRIPTION
70	1352085047		CAMARO, FIREBIRD V6 - 1993-96 26T, 26 SPL - 9.297" O.A.
70	1352085048R		INPUT CHEVY S10 4 CYL. 21T, 26 SPL (1352-216) 9.269" O.A.
70	1352085049		INPUT ISUZU, RODEO 2.5L 4 CYL. 21T, 24 SPL., 8.937" O.A.
70	1352085050	F3ZZ7017A	INPUT MUSTANG 3.35 TO 1, 23T - TAPERED POCKET BEARING, TO 1993 - 9.30" O.A.
70	1352085052		INPUT MUSTANG 1994-95 5.0 V8 - 3.35 TO 1, 23T, 9.97" O.A.
70	1352085055		INPUT MUSTANG 1994-95 5.0 V8 - 3.35 TO 1, 23T, TAPERED POCKET BEARING, 9.97" O.A.
70	1352085060		INPUT MUSTANG, TO 1993, 5.0 V6, 2.95 TO 1, 24T, TAPERED POCKET BRG
70	1352085063		INPUT ISUZU 9 1/4" O.A., 24 SPL. (21T)
71	1332131001	C3AZ7118A	NEEDLE BEARING (15 REQ.)
71	LM11910/LM11749	(A1)	POCKET BEARING - TAPERED
72	1352053005		SPACER - NEEDLE BEARING
73	1351097016	14071794	COVER - MUSTANG 4 CYL.
73	1352097015		COVER - MUSTANG V8, ISUZU
73	1352097017	10117840	COVER - CAMARO
73	1353097001		COVER - S10
74	1332183006		ALIGNMENT BOLT
75	1332183009	8127478	BOLT
76	1332141001	8127471	O-RING
77	1352100023		SHIFT RAIL - MAIN - FORD MUSTANG, T-BIRD
77	1352100016	10117841	SHIFT RAIL - MAIN - CAMARO, FIREBIRD - CAN USE 1351100003
77	1352100011	15546819	SHIFT RAIL - MAIN - S10
78	1352096002	E3ZZ7230B	FORK 1-2 - ALL
81	1332043004	8128387	SELECTOR ARM PIN
82	1352596003	D4ZZ7302A	SELECTOR ARM
83	1352190003		SELECTOR PLATE
84/79/10	1352127008	D8ZZ7L082A	FORK PADS
85	1352096004	E3ZZ7230C	FORK 3-4 - ALL
86	1300140004	E6ZZ7A247A	NEUTRAL SWITCH - FORD
87	1000043020	E5ZZ7C031A	PIN - NEUTRAL SWITCH
89	1352139005		RETAINING RING
90	1352193002		THRUST WASHER
92	1352525001	E5ZZ7174A	SYNCHRO CONE (FRICTION) 1-2
95	1352093001	E5ZZ7A044A	SYNCHRO KEY 1-2 (3 REQ.)
96	1352410011		PIN
98	1352070044		SYNCHRO SLEEVE 1-2, REV. SLIDER
99/97	1352156018	E5ZZ7109A	SYNCHRO SPRING 1-2 (2 REQ.)
100/93	1352091001	E5ZZ7107A	SYNCHRO RING 1-2
101			SEE ITEM #92
102/91	1352025001	E5ZZ7175A	SYNCHRO CONE 1-2
103	1352671035	E5ZZ7061A	MAIN SHAFT ASSY - 1-2 SYNCH - MUSTANG, USES NEEDLE PILOT BEARING, 23-57/64" O.A. (26-24-28) 28 SPL.
103	1352671039	11017818	MAIN SHAFT ASSY - 1-2 SYNCH - CAMARO 24-11/16" O.A., (26-24-27) 27 SPL. MECH. SPOOLS
103	1352671091		MAIN SHAFT ASSY - 1-2 SYNCH - FORD 23-7/8" (26-24-28) 28 SPL.
103	1352671102		MAIN SHAFT ASSY - 1-2 SYNCH - ISUZU 27 SPL.
103	1352671105		MAIN SHAFT ASSY - 1-2 SYNCH - S10 P/U, V6 CAMARO 1993 - ELECTRONIC SPEEDO - 24-1/16" O.A. (26-24-27) 27 SPL. MAGNETIC SPOOL
103	1352671111		MAIN SHAFT ASSY - 1-2 SYNCH - MUSTANG, FORD MOTOR-SPORT, 23-7/8" O.A. (26-24-28) 28 SPL. - TAPERED BEARING
104	1352103003		RACE - CAN USE 1352603006
105	1352132006		NEEDLE BEARING - CAN USE 1352603006
106	1352080030	E5ZZ7100A	1ST GEAR M/S MUSTANG V8 - 3.35 TO 1, 34T
106	1352080031		1ST GEAR M/S MUSTANG V8, S10 4 CYL. CAMARO V8 - 2.95 TO 1, 32T
106	1352080112		1ST GEAR M/S MUSTANG, T-BIRD 4 CYL. TURBO, 32T
106	1352080149		1ST GEAR M/S ISUZU 32T, 1993-95, S10, V6
106	1352080154		1ST GEAR M/S CAMARO V6 - 34T 1994-96
106	1352080032	E5ZZ7100B	1ST GEAR M/S MUSTANG, T-BIRD, 4 CYL. TURBO, 33T
107	25821/25877		BEARING M/S REAR

T5 W/C STYLE (cont.)

ILL #	MIDWEST #	REF #	REPLACEMENT PART DESCRIPTION
108	1352053003		SPACER
109	1352132002		NEEDLE BEARING 2ND GEAR
110	1352080027	10117827	2ND GEAR M/S CAMARO, FIREBIRD V6, 1988-92, 31T
110	1352080028	10117828	2ND GEAR M/S CAMARO, FIREBIRD V8, 1988-92, MUSTANG, MOTORSPORT 2.95 TO 1, 33T
110	1352080037	E5ZZ7102A	2ND GEAR M/S S10 R CYL. MUSTANG, T-BIRD, 4 CYL. TURBO, 31T
110	1352080060R	E5TZ7102B	2ND GEAR M/S MUSTANG 3.35 TO 1, 1985-89 V8, 1994-ON, V6, 30T
110	1352080113	E7ZZ7102A	2ND GEAR M/S MUSTANG, T-BIRD, 4 CYL. TURBO, 1987-93, 31T
110	1352080150		2ND GEAR M/S ISUZU, S10, V6, 31T
110	1352080152	F0ZZ7102A	2ND GEAR M/S MUSTANG, 3.35 TO 1, - 1990-95, V8, 31T
110	1352080155		2ND GEAR M/S CAMARO, FIREBIRD 1993-ON, V6, 37T
111	1352193004		THRUST WASHER
112	1300139028	E6ZZ7064A	SNAP RING
113	1352053004		SPACER - NEEDLE BEARING
114	FC66266.2		NEEDLE BEARING 3RD GEAR
115	1352080044R	E5ZZ7B340A	3RD GEAR M/S MUSTANG V6/V8, 27T - 3.35 TO 1
115	1352080046	E5ZZ7B340B	3RD GEAR M/S 4 CYL. CHEVY 27T
115	1352080048		3RD GEAR M/S 6 CYL. CHEVY S10, ISUZU 27T
115	1352080115	E7ZZ7B340A	3RD GEAR M/S 4 CYL. TURBO, MUSTANG, T-BIRD 26T
115	1352080151R	F0ZZ7B340A	3RD GEAR M/S MUSTANG V8 - 3.35 TO 1, HI-PERF., 1990-ON, 26T
115	1352080156		3RD GEAR M/S CAMARO V6 - 1994-96, 29T
115	1352083002R		3RD GEAR M/S CAMARO/MUSTANG - 2.95 TO 1, 30T
116	1352590011	15635335	SYNCHRO ASSY 3-4 w/o RINGS
116	1352590013	E6ZZ7124A	SYNCHRO ASSY 3-4 - RINGS
121	1351093001	E4ZZ7A044A	SYNCHRO KEYS 3-4 (3 REQ.)
122/118	1352156018	E5SZ7109A	SYNCHRO SPRING 3-4 (2 REQ.)
123/117	1352591003	E5SZ7107C	SYNCHRO RING 3-4
124	1351018005		THRUST RACE
125	1351132004	8134018	THRUST BEARING
N.I.	1352014004	E3ZZ7K201A	INTERLOCK PLATE
N.I.	1386021001		SHIFTER BOOT

KITS

T5RW	→ BEARING, SEAL & GASKET KIT
T5RWMK	→ BEARING KIT - SMALL PARTS, RINGS, FORK PADS
SP5-50W	→ SMALL PARTS KIT
RK5W	→ SYNCHRO RING KIT
K5W	→ GASKET & SEAL KIT



Rebuilt
**Transmissions &
Transfer Cases**

- ▶ Rebuild kits and parts are available.
- ▶ Transmissions & transfer cases are rebuilt using the highest standards.
- ▶ **BACKED BY WARRANTY**

**Motive
Gear®**

T18 STYLE

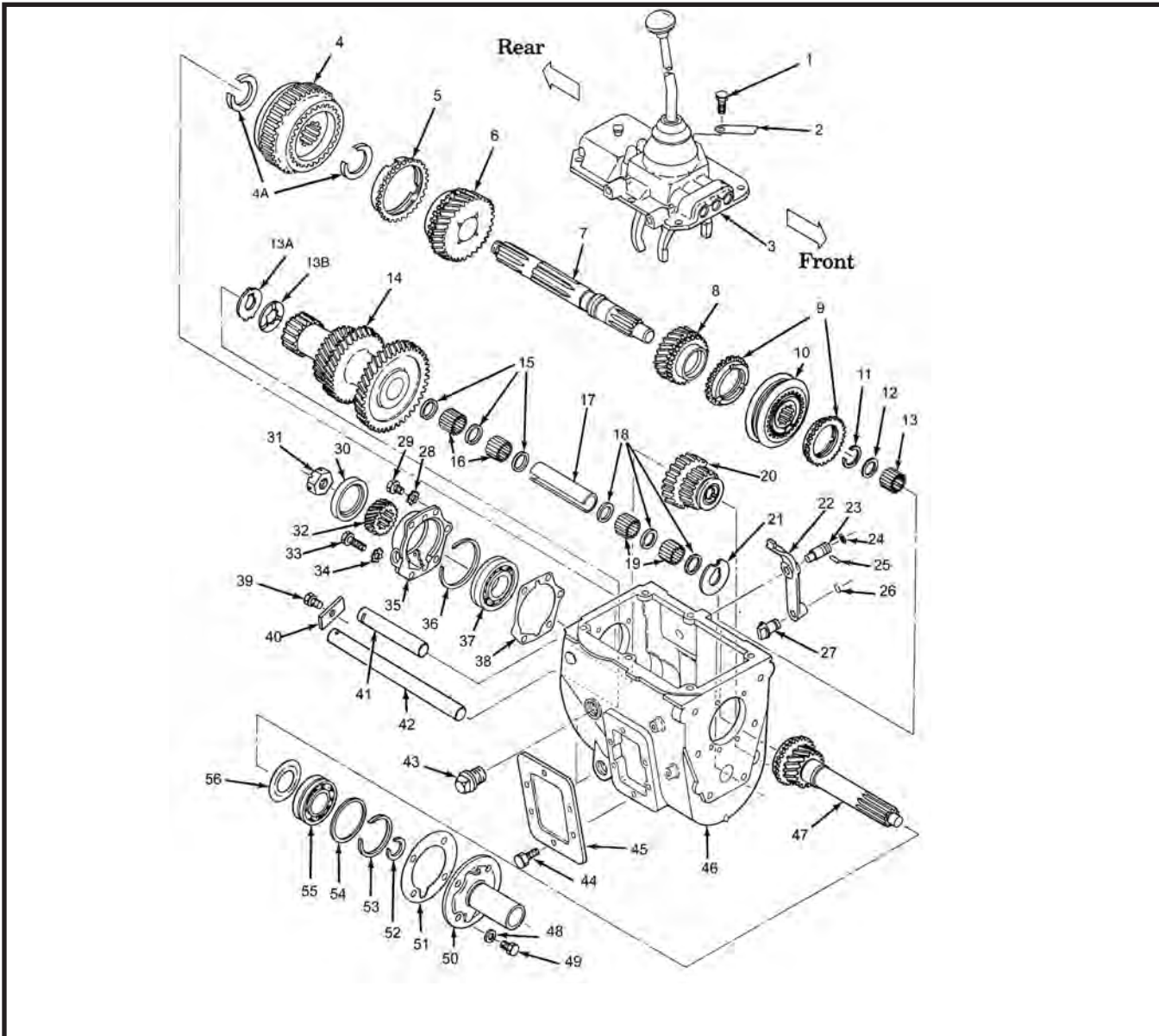

ILL #	MIDWEST #	REF #	REPLACEMENT PART DESCRIPTION
1	1000183040		BOLT, TOP COVER 3/8 - 16 X 7/8
2	1300199XXX		TAG, I.D.
3	1AT98-148E		SHIFT COVER ASSY - STEEL FORKS
3	1301597009		SHIFT COVER ASSY - ALUM. FORKS
3	2AT98-148E		SHIFT COVER ASSY - REMOTE SHIFT - 2 RAILS
3	3AT98-148E		SHIFT COVER ASSY - REMOTE SHIFT - 3 RAILS
4A	4745D	8MTH7160 / 0912333 / 15619303	SNAP RING
4	1301590005	1301590003 / 1301091002	SYNCHRO ASSY 1-2
4	T18-12R	C5TZ7100C / 130107003	SYNCHRO SLEEVE 1-2, M/S REV. 40T - (COIL SPRING) FLAT KEY
N.I.	130107003R		SYNCHRO SLEEVE 1-2, M/S REV. 40T (WIRE SPRINGS) SLATED
N.I.	1301156003	E3TZ7109A	SPRING WIRE 1-2, SYNCHRO
N.I.	1301093001	E3TZ7A044A / 83501861	KEY 1-2 SYNCHRO
N.I.	147487	353081S	BALL, SYNCHRO (USE COIL SPRING/BALL SYNCHRO)
N.I.	T87D-42A	0917117 / 8132959 / C1TT7234E	SPRING, COIL
5	T98-83	8MTH7175B / 0912340 / 71847R	SYNCHRO RING 1-2, TO 1982
5	1301091002	E3TZ7175B / 83501860	SYNCHRO RING 1-2, 1983-ON
6	1301080010	1301080010 / 0940498	2ND GEAR M/S - 33T
6	1301080012	C7TZ7176A	2ND GEAR M/S - 34T
6	1301080013		2ND GEAR M/S - 36T
N.I.	7412S	C5TZ7052A	SEAL - INPUT

T18 STYLE (cont.)

ILL #	MIDWEST #	REF #	REPLACEMENT PART DESCRIPTION
7	T18-2		MAIN SHAFT - FORD F500-F600, 14-3/4", 2WD 35 SPL.
7	1301171009		MAIN SHAFT - FORD F350-F500, 14-3/4", 2WD 10 SPL.
7	1301171005	E6TZ7061A	MAIN SHAFT - FORD F100-F350, 16-5/16", 2WD 28 SPL.
7	1301171006	E6TZ7061B	MAIN SHAFT - FORD F100-F350, 23-5/8", 2WD 28 SPL. (117" W.B.)
7	1301171007	E6TZ7061C	MAIN SHAFT - FORD F100-F350, 19-1/4", 4X4, 31 SPL.
7	T18-2B		MAIN SHAFT - JEEP J-SERIES/IHC, 14-5/8", 2WD, 10 SPL - 1-3/8" SPL.
7	T18-2D	0942937	MAIN SHAFT - JEEP/IHC, 14-1/2", 4WD, 6 SPL.
7	T18A-2		MAIN SHAFT - IHC, 14-3/4", 2WD, 10 SPL - 1-3/16" SPL.
7	1301171004		MAIN SHAFT - JEEP, 18-1/2", 4X4, 31 SPL.
7	1301171008		MAIN SHAFT - INDUSTRIAL (TAG# 173)
8	T18-11R	C5TZ7101A / 219999H1	3RD GEAR M/S - 24T - USE T87D-14 RING
8	T19-11R	C8TZ7101B / 8130254 / 8905653	3RD GEAR M/S - 24T - USE T19-14 RING
8	1309080015	E3TZ7176B	3RD GEAR M/S - 37T - USE T19-14 RING - TORQUE LOCK
8	T18A-11	C7TZ7101A	3RD GEAR M/S - 28T - USE T87D-14 RING
8	1309080001R		3RD GEAR M/S - 28T - USE T19-14 RING
9	T87D-14		SYNCHRO RING 3-4 - SMALL DIAM. 2.39 I.D.
9	T19-14R	C8TZ7107D	SYNCHRO RING 3-4 - LARGE DIAM. 2.58 I.D.
10	1AT87D-2.5CR		SYNCHRO ASSY 3-4 - w/o RINGS
10	1301590004	E3TZ7124C	SYNCHRO ASSY 3-4 - w/o RINGS - TORQUE LOCK
10	3AT87D-2.5C	A8TZ7124A	SYNCHRO ASSY 3-4, - T87D-14 RINGS
10	1AT19-2.5R	C8TZ7124F	SYNCHRO ASSY 3-4 - T19-14 RING
N.I.	4682AN	C8TZ7109B	SPRING, SYNCHRO
N.I.	T16-13	C5AZ7A044A	KEY, SYNCHRO
11	4746		SNAP RING
12	T97-29		SPACER, PILOT BEARING
13	C436Q		NEEDLE BEARING, PILOT (22 REQ.)
13B	T18-32	C5TZ7128B / 0939357	THRUST WASHER
13A	T98-33	8MTH7128 / 0912350	THRUST WASHER
14	T18-8R		CLUSTER GEAR - FORD, JEEP, IHC, INDUSTRIAL (#173), 43-36-27-16
14	T18B-8	C7TZ7113A	CLUSTER GEAR - FORD, DIESEL 38-32-26-16
14	T18C-8		CLUSTER GEAR - JEEP, IHC 37-32-24-16
14	T18A-8		CLUSTER GEAR - IHC 37-32-27-16
15	T98-87A	8MTH7482 / 0912355	SPACER - REV. IDLER BEARING
15	4248F		SNAP RING - REV. IDLER GEAR (2 REQ.)
16	C436Q	7EQH7193	NEEDLE BEARING (88 REQ.)
17	1000053021	E3TZ7115B	SPACER TUBE - NEEDLE BEARING
18	T97-29	8MTH7135 / 0912346	BEARING SPACER
18	T98-84A	C9TZ7728A	THRUST WASHER - REV. IDLER (2 REQ.)
19	B1316Q		NEEDLE BEARING - REV. IDLER (74 REQ.)
20	AT18-10R	C5TZ7141C / D4TZ7142A	REVERSE IDLER GEAR
21	T98-30	8MTH7119A / 0912348	THRUST WASHER
22	T98-54N	B6C7243A / 147922R1	REVERSE SHIFT ARM
23	T98-55N	B6C7236B / 147921R1	PIVOT - SHIFTING ARM
24	T89B-108		O-RING
25	103566	73757-S / 103565	TAPER PIN
26	4747A		SNAP RING
27	T19-51	C8TZ7409A	SHOE, REVERSE SHIFTING
29	1300183023		BOLT, REAR EXTENSION - 3/8 - 16 X 1"
30	7692S		SEAL - OUTPUT FORD 28 SPL.
30	473442		SEAL - OUTPUT FORD 31 SPL.
30	473468		SEAL - OUTPUT JEEP 10 SPL.
30	9613S		SEAL - OUTPUT JEEP 31 SPL.
30	T9-110		SEAL - OUTPUT - INDUSTRIAL
N.I.	1301566003		TAIL HOUSING ASSY - BUSHING, LONG
N.I.	R11-77D		BUSHING
N.I.	1301566010	E0TZ7A039H	ADAPTER ASSY - EARLY STYLE (S.A.E.)
N.I.	1301566011	E7TZ7A039A	ADAPTER ASSY - LATE STYLE (METRIC)
N.I.	1000043010		DOWEL PIN
31	4775W		NUT, M/S
32	T18-169		SPEEDOMETER GEAR 7T
32	T18-169A		SPEEDOMETER GEAR 6T GREEN
32	T18-169D		SPEEDOMETER GEAR 8T BROWN
N.I.	1000109001		SPEEDO BALL
N.I.	4816		SNAP RING
N.I.	4652JJ		WASHER
33	1300183026		BOLT, REAR BEARING CAP 3-8/16" X 1-7/8"
34/28	114606		LOCK WASHER 3/8"
35	AT98-7B	IHC-93668R11	RETAINER ASSY - INDUSTRIAL
35	1301066004	E0TZ7A039D	RETAINER ASSY - FORD, SHORT

T18 STYLE (cont.)

ILL #	MIDWEST #	REF #	REPLACEMENT PART DESCRIPTION
36	4745		SNAP RING
37	1308L		BEARING, MAIN SHAFT
N.I.	1000031020		YOKE, M/S FORD
N.I.	1300199XXX		TAG, I.D.
38	1301045003		GASKET - AUTOMOTIVE RETAINER
38	T98-145.5C		GASKET - INDUSTRIAL RETAINER
39	1300183011		BOLT, 3/8 - 16 X 3/4"
40	4501		LOCK PLATE
41	1301568002	C5TZ7140A / 0912359	SHAFT ASSY w/ O-RING - NEW IDLER
41	1301068002	C5TZ7140A / 0912359	SHAFT (USE w/ O-RING) REV. IDLER
41	T97-35	C5TZ7140A / 0912359	SHAFT (USE w/o O-RING) REV. IDLER
N.I.	1300141022		O-RING
N.I.	T98-85A	8MTH7143B	SLEEVE - REV. IDLER SHAFT
42	1301568001		COUNTERSHAFT ASSY - O-RING
42	1301068001		COUNTERSHAFT (USE w/ O-RING)
42	T18-3		COUNTERSHAFT (USE w/o O-RING)
43	1300052004		PIPE PLUG (DRAIN, FILL)
44	1000183041	15580321	BOLT, HEX 3/8 - 16 X 5/8
45	T53-160B		PTO COVER
46	1301565003	E0TZ7A039C	CASE ASSY - INDUSTRIAL, FORD
46	1301565008	E0TZ7006A	CASE ASSY - FORD
47	T18-16A	C5TZ7017L	INPUT - FORD 9-1/8" 17T (F100-F350) - USE T87D-14 RING, 308L1 BEARING
47	T18-16L	C8TZ7017R	INPUT - FORD 9-1/8" 17T (F100-F350) - USE T19-14 RING, 308L1 BEARING
47	1301085020	E3TZ7017F	INPUT - FORD 9-1/8" 17T (F100-F350) - USE T19-14 RING, 308L BEARING
47	1301085021	E3TZ7017G	INPUT FORD 9-1/8" 17T (F100-F350) - USE T19-14 RING, 308L BEARING
47	T18-16		INPUT - FORD 9-1/2" 17T (F500-F600) T87D-14 RING - SM. CONE
47	T19-16A	C8TZ7016M	INPUT - FORD 9-1/2" 17T (F500-F600) T19-14 RING
47	T18B-16	C7TZ7017A	INPUT - FORD 9-11/16" 22T (F350-F500) DIESEL T87D-14 RING
47	T18B-16A	C8TZ7017N	INPUT - FORD 9-11/16" 22T (F350-F500) DIESEL T19-14 RING
47	T18-16D		INPUT - JEEP J-SERIES 327 - 8 CYL. 14-1/16", 17T
47	T18-16K		INPUT - JEEP J-SERIES 350 - 8 CYL. 15-5/8", 17T
47	T18C-16A		INPUT - JEEP CJ 225 - 6 CYL. 12-15/16", 23T
47	1301085001		INPUT - JEEP J-SERIES - 8 CYL. 16-11/16", 23T
47	1301085002		INPUT - JEEP J-SERIES 8 CYL. 16-11/16", 17T
47	1301085003	8122416	INPUT - JEEP CJ/J-SERIES 6 CYL. 12", 23T
47	1301085007	8125946	INPUT - JEEP J-SERIES 8 CYL. 15-15/16", 17T, USE T87D-14 RING
47	1301085009		INPUT - JEEP CJ 6 CYL. 10", 23T - USE T87D-14 RING
47	1301085011	8128103	INPUT - JEEP CJ 6 CYL. 10", 17T - USE T87D-14 RING
47	1301085012		INPUT - JEEP CJ 6 CYL. 12", 17T
47	1301085013		INPUT - JEEP CJ 8 CYL. 15-15/16", 17T, USE T19-14 RING
47	1301085014		INPUT - JEEP J-SERIES 6 CYL. 12", 17T, USE T19-14 RING
47	1301085015	CAN USE 1301085011 & T87D-14	INPUT - JEEP CJ 6 CYL. 10", 17T - USE T19-14 RING
47	1301085018	8132656	INPUT - 15-7/8", 17T
47	1301085019		INPUT - 8-5/16", 6 CYL. 17T
47	T18-16B		INPUT - 4-9/16", 17T
47	T18-16C		INPUT - INDUSTRIAL (TAG# 173)
47	T18A-16A		INPUT - IHC 13-1/16", 23T
47	T18-16N		INPUT - IHC 13-1/16", 17T (15mm PILOT)
47	T18C-16		INPUT - IHC 13-1/16", 23T (15mm PILOT)
48	114605		WASHER - FRONT RETAINER 5/16
49	179817		BOLT - FRONT RETAINER 5/16 - 18 X 3/4
50	T98-6N		RETAINER, FRONT BEARING - INDUSTRIAL (TAG# 173)
50	T18-6	C5TZ7050H	RETAINER, FRONT BEARING - FORD TRUCK - 9-1/8"
50	T98A-6	B6C-7050A	INPUT F100-F350, JEEP - 9-15/16" INPUT OR 16-5/8" INPUT RETAINER, FRONT BEARING - FORD TRUCK - 9-1/2" OR 9-11/16" INPUT F350-F500
50	T18-6A		RETAINER, FRONT BEARING - JEEP - 14-1/16" INPUT
50	T18-6B		RETAINER, FRONT BEARING - JEEP - 12" INPUT
50	T18-6E		RETAINER, FRONT BEARING - JEEP - 15-5/8" INPUT
50	T18-6B		RETAINER, FRONT BEARING - JEEP - 12-5/16" INPUT
50	1301027002		RETAINER, FRONT BEARING - JEEP - 12" INPUT, 1.41" TUBE
50	1301027008	8125945	RETAINER, FRONT BEARING - JEEP - 15-7/8" INPUT
50	1301027010		RETAINER, FRONT BEARING - JEEP - 12" INPUT, 1.31" TUBE
50	1301027011		RETAINER, FRONT BEARING - JEEP - 12" INPUT, SEAL TYPE
50	1301027012	8132654	RETAINER, FRONT BEARING - JEEP - 15-7/8" INPUT, SEAL TYPE
50	AT18A-6		RETAINER, FRONT BEARING - IHC - 8.89" INPUT
50	AT18C-6		RETAINER, FRONT BEARING - IHC - 13-1/16" INPUT
51	T98-145C		GASKET - FRONT RETAINER
52	4816		SNAP RING

T18 STYLE (cont.)

ILL #	MIDWEST #	REF #	REPLACEMENT PART DESCRIPTION
53	4745E		SNAP RING
54	4744		SPACER, FRONT BEARING
55	308L		BEARING, INPUT - WIDE - EARLY .9055"
55	308L1		BEARING, INPUT - NARROW - LATE .7874"
56	T90A-136A		OIL BAFFLE

KITS

T82AR	→	BEARING GASKET & SEAL KIT w/ SMALL PARTS KIT BALL BEARING DESIGN
T82BR	→	BEARING, SEAL & GASKET KIT w/ SMALL PARTS KIT TAPERED BEARING DESIGN
T82RAMK	→	BEARING, SEAL & GASKET MASTER KIT w/ RINGS
T82BRMK	→	BEARING, SEAL & GASKET MASTER KIT w/ RINGS TAPERED BEARING DESIGN
SP18-50	→	SMALL PARTS KIT
G518-55	→	GASKET KIT
K82A	→	GASKET AND SEAL KIT (GAS)
K82B	→	GASKET AND SEAL KIT (DIESEL)
K82	→	GASKET AND SEAL KIT (T98)

**Motive
Gear®**

T18 STYLE SHIFTER HOUSING

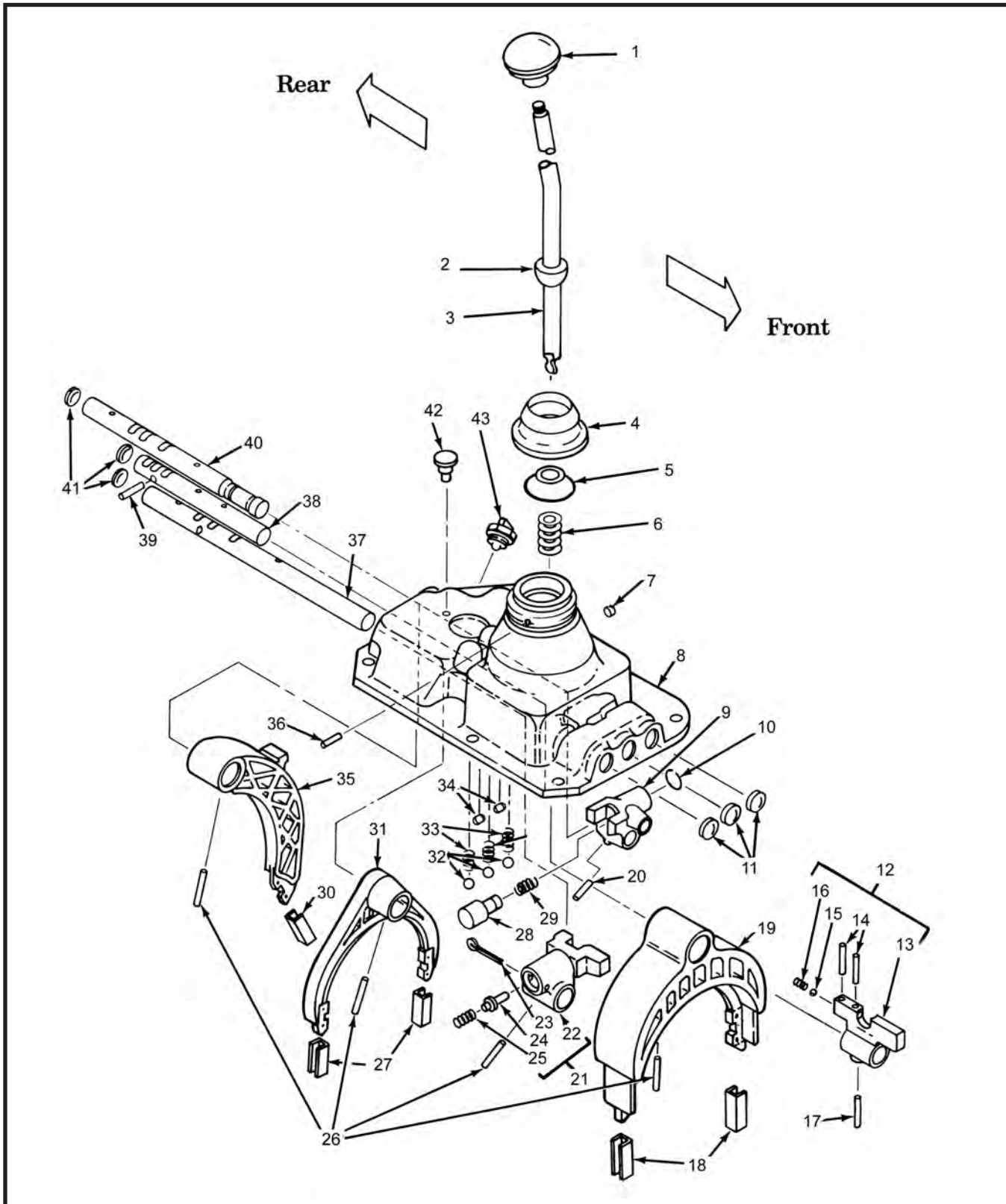

T18 STYLE, SHIFTER HOUSING (cont.)

ILL #	MIDWEST #	REF #	REPLACEMENT PART DESCRIPTION
1	C37J-50A		CONTROL BALL
2	N.S.S.		FULCRUM BALL
3	AC98-2U		CONTROL LEVER 29-1/8" STRAIGHT
3	AC98A-2C		CONTROL LEVER 26-3/8" CURVED
3	AC98A-2L		CONTROL LEVER 34-5/8" STRAIGHT
3	AC98A-2BE		CONTROL LEVER 30-3/4" BENT
3	1301598010		CONTROL LEVER 18-3/4" JEEP*
4	4496L	8MTH7220	CAP, HOUSING
5	4497H		SPRING WASHER
6	4498B		SPRING
7	4572		PLUG
8	T98-148	8MTH7222B	CONTROL HOUSING (IRON FORKS)
8	1301097009	ESTZ7222A	CONTROL HOUSING (ALUM. FORKS)
9	T18-37	D1TZ7232A / 0948705	LUG, REVERSE RAIL (IRON FORKS)
9	1301046007		LUG, REVERSE RAIL (ALUM. FORKS)
10	4747B		C-WASHER
11/41	103892		WELCH PLUG
12	1301596002	E3TZ7279C	SHIFT LUG ASSY 3-4 - (ALUM. FORK)
13	1301096013		SHIFT LUG 3-4
14	9414521		ROLL PIN
15	1309109001		BALL
16	1301156002	E1TZ7234A	SPRING
18	1000127006	D3TZ7C430D / 8130274	FORK PADS 3-4 - USE - (ALUM. FORK) (2 REQ.)
19	1301096002	D3TZ7230B / 8130264	SHIFT FORK 3-4 - (ALUM.)
19	T98A-23	D2TZ7289A	SHIFT FORK 3-4 - (IRON)
21	1301596003		SHIFT LUG 1-2 ASSY
22	1301096014		SHIFT LUG ONLY, 1-2 (ALUM. FORKS)
22	1301096011		SHIFT LUG, 1-2 (IRON FORKS)
23	121673		COTTER PIN
24	1301108002		PLUNGER
25	1301156004	E5TZ7234B	SPRING
26/17/20	1000043016	8134040	ROLL PIN
27	1000127006	D3TZ7C430D / 8130274	FORK PAD (ALUM. FORK) (2 REQ.)
28	1309108001		PLUNGER
29	T9A-39	0912393	SPRING, PLUNGER (ALUM. FORKS)
29	1309156003		SPRING, PLUNGER (IRON FORKS)
30	1000127005	D3TZ7K430E	FORK PAD, REVERSE
31	T98A-24	C8TZ7231F	SHIFT FORK, 1-2 (IRON)
31	1301096001	D3TZ7231A / 8130266	SHIFT FORK, 1-2 (ALUM.)
32	453593		STEEL BALL
33	T8B-42	0642769	POPPET SPRING
34	T8-86	BB7233 / 0912389	PLUNGER, INTERLOCK
35	1301096003	D3TZ7231C / 8130263	SHIFT FORK, REVERSE (ALUM.)
36	4499A		PIN - SHIFT LEVER
37	1301100007	C8TZ7240B / 0948701	RAIL, 1-2 (IRON FORKS)
37	1301100002	D3TZ7240G	RAIL, 1-2 (ALUM. FORKS)
38	T18-20	C8TZ7241B	SHIFT RAIL 3-4 - (IRON FORK)
38	1301100003	D3TZ7241B	SHIFT RAIL 3-4 - (ALUM. FORK)
39	T97-86	B7QH7235A / 0912388	INTERLOCK PIN
40	T98A-99A		RAIL, REVERSE (IRON FORKS)
40	1301100006		RAIL, REVERSE (ALUM. FORKS)
42	T94-95		BREATHER ASSY
43	AT19-102		REVERSE LIGHT SWITCH

T19 STYLE

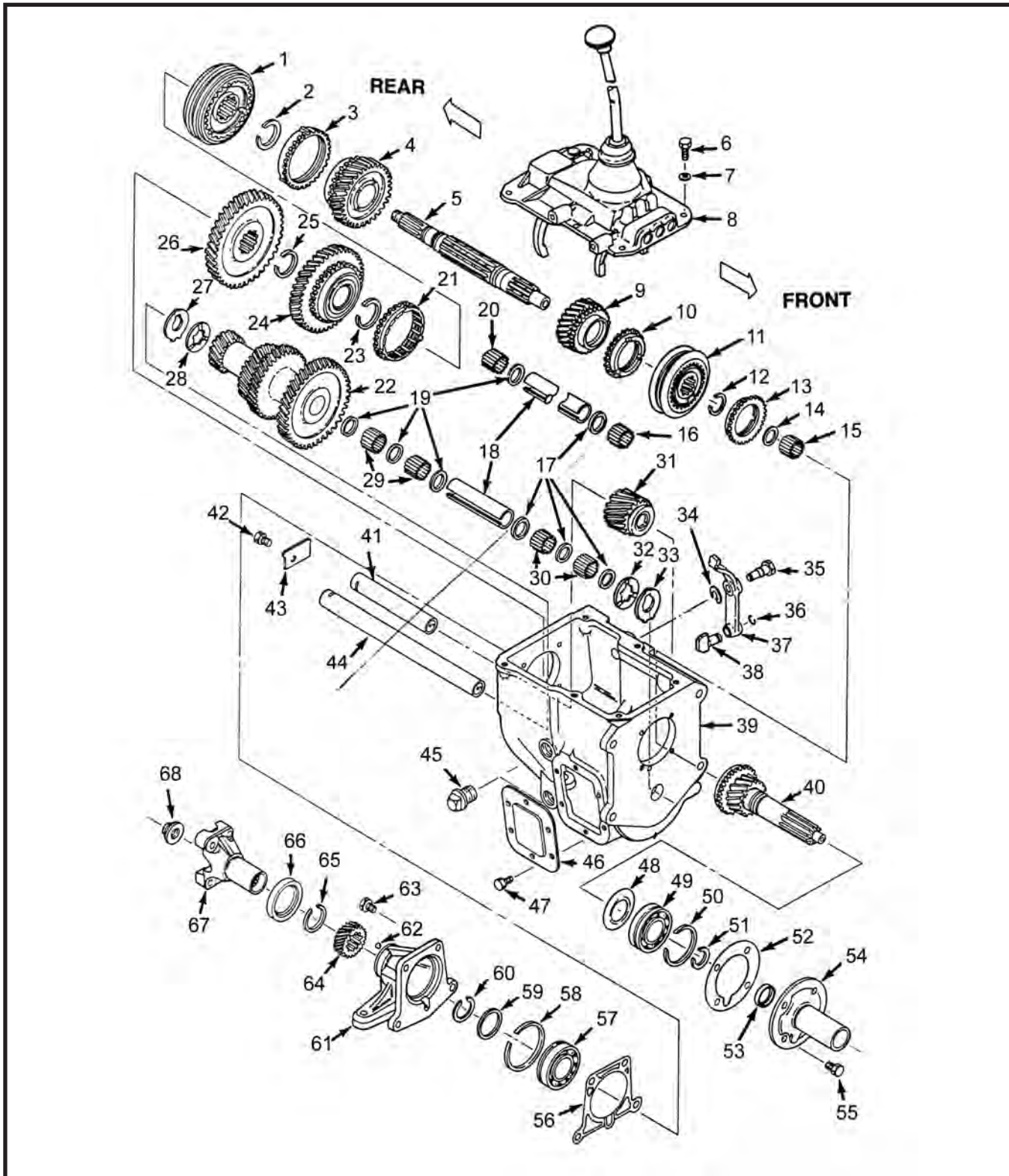

T19 STYLE (cont.)

ILL #	MIDWEST #	REF #	REPLACEMENT PART DESCRIPTION
1	1309590008		1-2 ASSY w/ RINGS
1	AT19-80R		SYNCHRO ASSY, 1-2 - LESS RINGS
N.I.	4682AM	C8TZ7109A	SPRING, SYNCHRO 1-2 (2 REQ.)
N.I.	T19-82	C8TZ7A044C	KEY, SYNCHRO 1-2 (2 REQ.)
2	4745D	8MTH7160	SNAP RING
4	1309080008R		2ND GEAR M/S, 33T
4	1309080010	E4TZ7176A	2ND GEAR M/S, 36T (BALL BRG. INPUT)
4	1309080011	E4HZ7176A	2ND GEAR M/S, 36T (TAPERED BALL BRG.)
4	1309080015	E3TZ7176B	2ND GEAR M/S, 37T
5	T19-2	E4HZ7061B	MAIN SHAFT - FORD 14-3/4", 35 SPL. (BALL BRG.)
5	1309171006	E0HZ7061B	MAIN SHAFT - FORD 14-3/4", 35 SPL. (TAPERED BRG.)
5	1309171010	E6TZ7061D	MAIN SHAFT - FORD 16-3/4", 28 SPL., 2WD
5	1309171007		MAIN SHAFT - FORD 19-1/4", 31 SPL.
5	1309171001		MAIN SHAFT - IHC 14-5/8", 10 SPL.
5	1309171004		MAIN SHAFT - IHC 14-13/16", 6 SPL. (DANA T/CASE)
5	T19-2AR		MAIN SHAFT - INDUSTRIAL 14-3/4", 10 SPL.
6	179838		BOLT - HEX 3/8 - 16 X 7/8"
6	1300183023		BOLT - HEX 3/8 - 16 X 1"
7	103321		LOCK WASHER
N.I.	1309191001		LIFT HANGER
N.I.	1300199-XXX		I.D. TAG
8	1309597001		TOP COVER ASSY
8	1309097003	E5TZ7222B	TOP COVER - BARE
9	T19-11R	C8TZ7101B/8130254	3RD GEAR, M/S, 24T
9	1309080001R	E3TZ7101C	3RD GEAR, M/S, 28T (BALL BRG. INPUT)
9	1309080004	E0HZ7101A	3RD GEAR, M/S, 28T (TAPERED BRG. INPUT)
11	1AT19-2.5R	E3TZ7124B	SYNCHRO ASSY 3-4 (BALL BRG. INPUT)
11	1309590003	E0HZ7124A	SYNCHRO ASSY 3-4 (TAPERED BRG. INPUT)
N.I.	4682AN		SPRING, SYNCHRO (2 REQ.)
N.I.	T16-13	C5AZ7A044A/3182573	KEY, SYNCHRO (3 REQ.)
12	4746		SNAP RING
13/10	T19-14R		SYNCHRO RING, 3-4
N.I.	1000132021	E0HZ7C096A	THRUST BEARING (USE WITH TAPERED INPUT)
N.I.	1338193008	E0HZ7E487A	THRUST RACE (USE WITH TAPERED INPUT)
14	T97-29	8MTH7135/0912346	THRUST SPACER
15	T97-166		NEEDLE BEARING, M/S PILOT, (22 REQ.)
17/19	T97-29	8MTH7135/0912346	NEEDLE BEARING SPACER
18	T98-2E		SPACER, C/S BRG., (8 REQ.)
21/3	1309091001	E4TZ7107A	SYNCHRO RING, 1-2
22	T19-8R	C8TZ7113C	CLUSTER GEAR, FORD/IHC 43-36-27-16
22	1309077001	E4TZ7113E	CLUSTER GEAR, FORD/IHC 37-32-24-16
22	1309077004	E3TZ7113E	CLUSTER GEAR, FORD 45-32-25-16
23	6003 - 6003B		SNAP RING, SELECTIVE
24	1309080012	E3TZ7100K	1ST GEAR M/S (TAPERED BRG. INPUT) - CAN USE 1309080013R
24	1309080013R	E3TZ7100K	1ST GEAR M/S (BALL BRG. INPUT)
25	6003B		SNAP RING
26	T19-46R	C8TZ7142E	REV. GEAR, M/S (BALL BRG. DESIGN)
30/16/29/20	C436Q	7EQH7193	NEEDLE BRG, COUNTERSHAFT (88 REQ.)
31	1309584002	E0HZ7141A	REV. IDLER GEAR
N.I.	4828F		SNAP RING, REV. IDLER (2 REQ.)
N.I.	T98-84A	C9TZ7728A	RING, SPACER (2 REQ.)
N.I.	T97-166		NEEDLE BRG, REV. IDLER (74 REQ.)
N.I.	T98-87A	8MTH7482/0912355	SPACER, NEEDLE BEARING
N.I.	T98-85A	8MTH7143B	SLEEVE
N.I.	1301568001		COUNTERSHAFT - O-RING
N.I.	1300141022		O-RING
32/28	T18-32	C5TZ7128B/0939357	THRUST WASHER
33/27	T98-33	8MTH7128/0912350	THRUST WASHER
34	1332139003	371197S/8127469	SNAP RING
35	457008		ROLL PIN
N.I.	T19-55	C8TZ7K179A	PIVOT - REV. SHIFT ARM
35	1352183002	E7TZ7K024A	BOLT - REV. PIVOT
36	1000139052		SNAP RING
36	4747A		SNAP RING
37	T19-54	C8TZ7243A	REV. SHIFT ARM - NEW STYLE
37	1309098012	E3TZ7243A	REV. SHIFT ARM - EARLY STYLE
38	T19-51	C8TZ7409A	SHIFT SHOE
39	CALL WITH APPLICATION		MAIN CASE

T19 STYLE (cont.)

ILL #	MIDWEST #	REF #	REPLACEMENT PART DESCRIPTION
40	1309085008R	E4TZ7017B	INPUT - FORD [®] F100-F350, 9-1/8", 23T - 308L1 BRG., (CAN USE 1309085013R W/308L BRG. (NO OIL BAFFLE))
40	1309085012R	E3TZ7017B	INPUT - FORD F100-F350, 9-1/8", 22T - 308L1 BRG.
40	T19-16A	C8TZ7017M	INPUT - FORD F500-F800, 9-1/2", 17T
40	1309085006		INPUT - FORD F500-F800, 9-1/2", 23T
40	T19-16	C8TZ7017H	INPUT - FORD F500-F800, 13", 17T DIESEL, (BALL BRG.)
40	1309085009	E0HZ7017B	INPUT - FORD F500-F800, 13", 23T DIESEL, (TAPERED BRG.)
40	1309085003		INPUT - IHC, 13-1/16", 17T
40	1309085004		INPUT - IHC, 13-1/16", 23T
40	1309085013R	E6TZ7017A	INPUT - FORD F100-F350, 9-1/8", 23T, - 308L BRG.
40	1309085014		INPUT - FORD F100-F350, 9-1/8", 22T, - 308L BRG., (CAN USE 1309085012 w/ 308L1 BEARING)
41	T97-35	C5TZ7140A/0912359	SHAFT - REV. IDLER (w/o O-RING)
42	1300183011		BOLT, HEX 3/8 - 16 X 3/4
43	T19-48		LOCK PLATE
N.I.	1301568002	C5TZ7140A/0912359	SHAFT - REV. IDLER - O-RING
N.I.	1300141022		O-RING
44	T18-3		COUNTERSHAFT (w/o O-RING)
45	444592		PLUG, DRAIN - FILL 3/4"
46	T53-160B	C8TZ7A044C	PTO COVER
47	1000183041	15580321	BOLT - HEX 3/8" - 16 X 5/8"
48	T90A-136A	8MTH7040/0640893	OIL BAFFLE
49	308L	C4TZ7065A	BEARING INPUT (BALL) WIDE
49	308L1		BEARING INPUT (BALL)
49	M802048		BEARING, INPUT (TAPERED)
N.I.	M802011		RACE, M/S REAR BEARING (TAPERED)
50	4745E	8MTH7060	SNAP RING
51	4816-4816C	B6C7064A/B6C7064D	SNAP RING - SELECTIVE
52	T98-145C	8MTH7051B	GASKET - FRONT RETAINER
53	7412S		SEAL - INPUT
N.I.	1309037001/ 1309037007	E0HZ7051A	SHIM, FRONT BEARING (TAPERED)
54	T18-6	C5TZ7050H/8126874	RETAINER - FRONT BEARING - FORD F100-F350 9-1/8" INPUT
54	T98A-6	B6C7050A	RETAINER - FRONT BEARING - FORD F500-F800 9-1/2" INPUT
54	T19-6		RETAINER - FRONT BEARING - FORD F500-F800 13" INPUT (BALL BRG)
54	1309107001		RETAINER - FRONT BEARING - FORD F500-F800 13" INPUT (TAPERED BRG)
54	AT18C-6		RETAINER - FRONT BEARING - IHC 13 1/16" INPUT
55	4776A		BOLT - HEX 5/16 - 18 X 3/4"
56	1301045003		GASKET, REAR RETAINER
57	1308L		BEARING, M/S (BALL)
58	4745E	8MTH7060	SNAP RING
59	4652J		WASHER
60	4816	B6C7064A	SNAP RING
61	1301066004	E0TZ7A039D	RETAINER, M/S REAR, FORD F100-F350
61	T19-7	C8TZ7085F	RETAINER, M/S REAR, FORD (C8TZ7085F)
61	1301566010	E0TZA039H	ADAPTER ASSY, 4X4 S.A.E.
61	1301566011	E7TZ7A039A	ADAPTER ASSY, 4X4 METRIC
61	1309607004	E4HZ7085D	RETAINER, M/S REAR (TAPERED BRG (F500-F800))
62	1000109001	353351-S/3213666	BALL, SPEEDO
63	1000183038		BOLT - HEX 1/2" - 13 X 1-3/8"
64	T18-169D		SPEEDO GEAR (8T BROWN)
65	4734		SNAP RING
66	7692S		SEAL - M/S FORD 28 SPL.
66	473442		SEAL - M/S FORD 31 SPL.
66	450519		SEAL - M/S FORD 2/TAPERED BEARING
66	8160S		SEAL - M/S IHC, 10 SPL. 2-1/2" O.D.
66	473463		SEAL - M/S IHC, 10 SPL. 3" O.D.
66	473468		SEAL - M/S IHC, 6 SPL.
67	100031020	E1TZ7B198A	YOKE - REAR FORD [®] F100-F350
68	4775W		NUT 1/2" - 20 - 28 SPL.
68	4775L		NUT 1/2" - 20 - 35 SPL.
N.I.	135629		LOCK WASHER 1/2"
N.I.	4852D		WASHER, REAR NUT

T19 STYLE (cont.)

KITS

T82AR19	→ BEARING GASKET & SEAL KIT - BALL BRG. INPUT
T82BR19	→ BEARING GASKET & SEAL KIT - TAPERED BRG. INPUT
T82RA19MK	→ BEARING MASTER KIT, INCLUDE. SMALL PARTS, SYNCHRO RING, SYNCHRO KEYS & SPRINGS
T82BR19MK	→ BEARING MASTER KIT, INCLUDE. SMALL PARTS, SYNCHRO RING, SYNCHRO KEYS & SPRINGS
K82A	→ GASKET & SEAL KIT - GAS
K82B	→ GASKET & SEAL KIT - DIESEL
SP19-50	→ SMALL PARTS KIT
GS19-55	→ GASKET SET
T19-K1	→ SYNCHRO KEY & SPRING KIT 1-2
T19-K3	→ SYNCHRO KEY & SPRING KIT 3-4



T19 STYLE, SHIFTER HOUSING

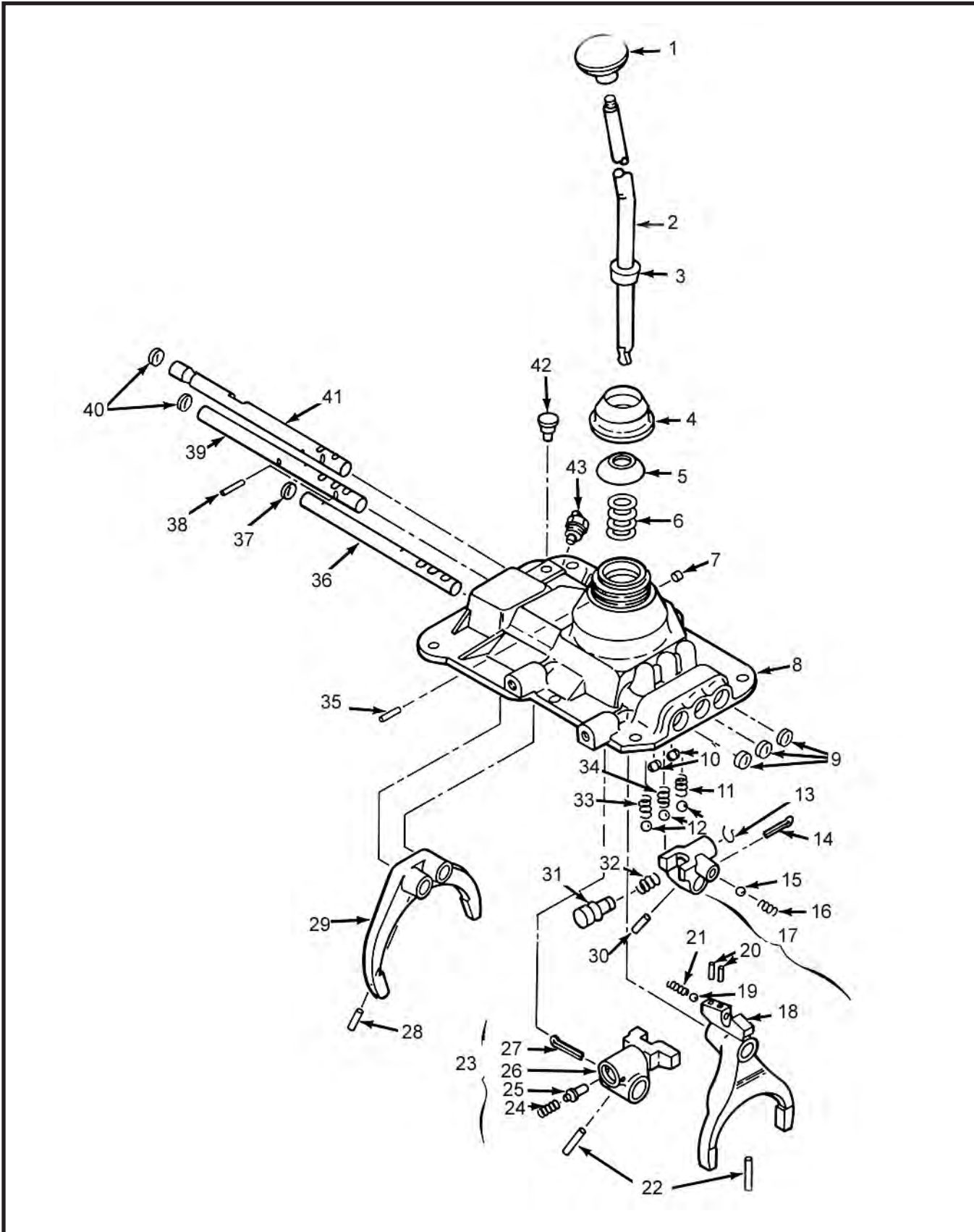

T19 STYLE, SHIFTER HOUSING (cont.)

ILL #	MIDWEST #	REF #	REPLACEMENT PART DESCRIPTION
1	C37J-50A		HAND BALL
2	AC98-2U		CONTROL LEVER - 29-1/8" STRAIGHT
2	AC98A-2C		CONTROL LEVER - 26-3/8" CURVED
2	AC98A-2L		CONTROL LEVER - 34-5/8" STRAIGHT
2	AC98A-2BE		CONTROL LEVER - 30-3/4" BENT
4	4496L	8MTH7220	CAP - CONTROL HOUSING
5	4497H		SPRING WASHER
6	4498B	B7227/8127059 / 15640287	SPRING
7	4572D		TAPER PLUG
8	CALL WITH APPLICATION		COVER ASSY
9/37/40	103892		EXPANSION PLUG
10	T8-86	BB7233 / 0912389	INTERLOCK PLUNGER
11/33	T8B-42	BB7234 / 0642769/72285	POPPET SPRING
12	1300109003	372720S / 15546802	STEEL BALL - 3/8"
13	4747B		C WASHER
14	108630		COTTER PIN
15	1000109001	353351-S/3213666	STEEL BALL
N.I.	T18-37	D1T27232A / 0948705	SHIFT RAIL LUG
16	4750	A8T7234A	POPPET SPRING
17	1309596002	D2T27289A	FORK ASSY 3-4 ANTI-RATTLE
18	1309096007		SHIFT FORK 3-4 ANTI-RATTLE
18	T19-23	D2T27289A	SHIFT FORK 3-4 - EARLY DESIGN
19	1309109001		STEEL BALL
20	9414521		ROLL PIN
21	1301156002	E1T27234A	SPRING
22/30/28	1000043016	8134040	ROLL PIN
23	1309596003		SHIFT RAIL, LUG ASSY 1-2
24	1301156004	E5T27234B	SPRING
25	1301108002		BIAS PLUNGER
26	1309096006		SHIFT LUG 1-2 - LATE STYLE
26	T19-38		SHIFT LUG 1-2 - EARLY STYLE
27	121673		COTTER PIN
29	T19-24		SHIFT FORK 1-2
31	1309108001		PLUNGER, REVERSE
32	1309156003		SPRING, PLUNGER
34	T98-42		POPPET SPRING
35	4499B	D2TA7B125A	PIN, SHIFT LEVER
36	T19-21	C8T27240E	SHIFT RAIL 1-2
38	T97-86	B7QH7235A / 0912388	INTERLOCK PIN
39	T19-20	C8T27241D	SHIFT RAIL 3-4
41	T19-99	C8T27242D	SHIFT RAIL, REVERSE
42	T94-95		BREATHER ASSY
43	AT19-102		REVERSE LIGHT SWITCH



A833 - NP440 - MY6 STYLE
DODGE® P/U 1976-90
RAM VAN, RAM WAGON 1976-87
CHEVY® TRUCK 1981-86

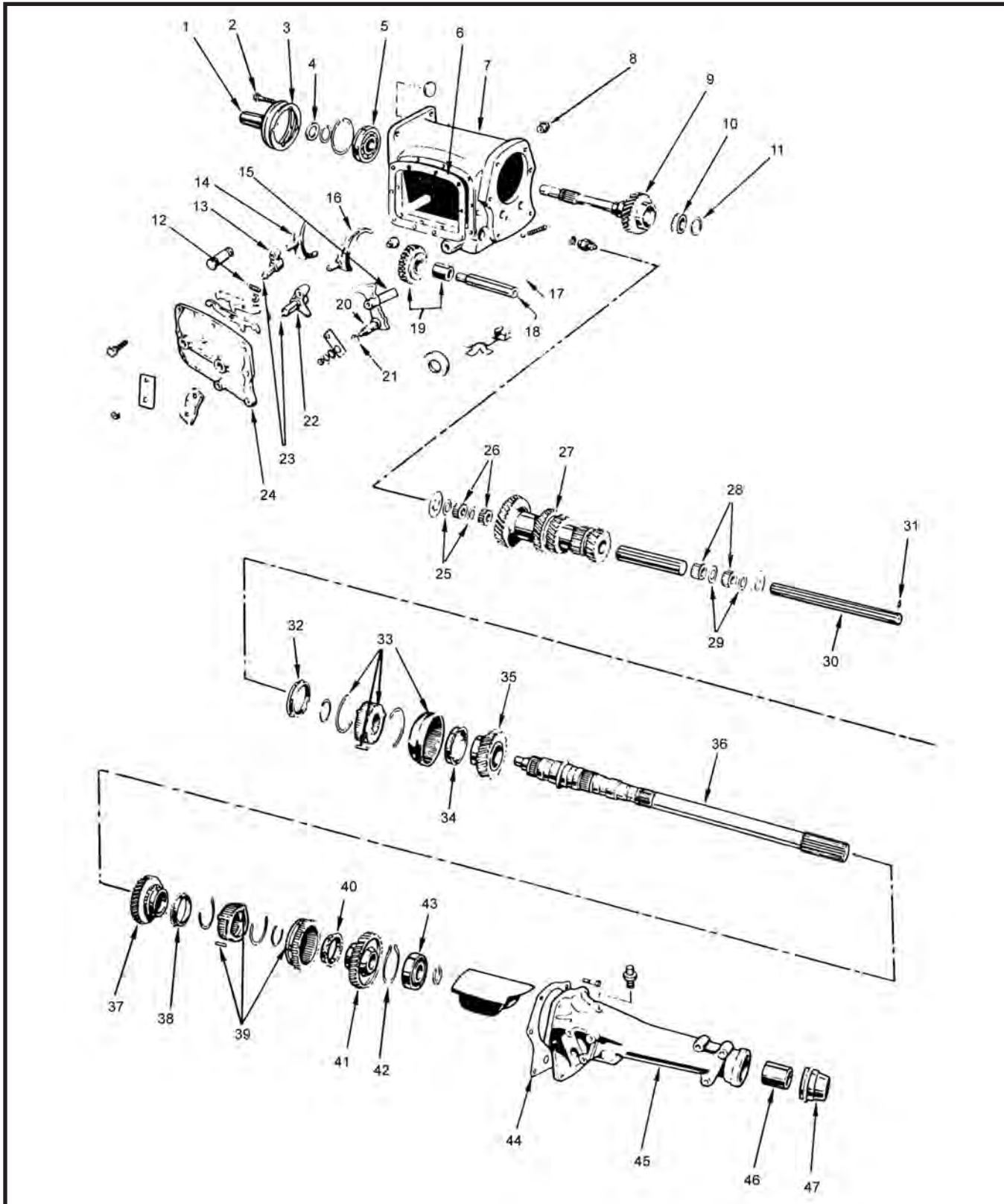

A833 - NP440 - MY6 STYLE (cont.)

ILL #	MIDWEST #	REF#	REPLACEMENT PART DESCRIPTION
1	2801892		RETAINER - FRONT BRG - CHRYSLER CAR, 308 BRG. 18 SPL. INPUT, 4-13/16" O.D. - CAST #97621
1	3410395		RETAINER - FRONT BRG - CHRYS. CAR, 307 BRG. 23 SPL. INPUT, 4-3/8" O.D. CAST #94796
1	2892256		RETAINER - FRONT BRG - CHRYS. CAR, 307 BRG. 23 SPL. INPUT, 4-13/16" O.D. - CAST #97619
1	2960122		RETAINER - FRONT BRG - CHRYS. CAR, 307 BRG. 23 SPL. INPUT, 5-1/8" O.D. - CAST #97728
1	3410247		RETAINER - FRONT BRG - CHRYS. CAR, 308 BRG. 23 SPL. INPUT, 4-13/16" O.D. - CAST #99369
1	3878596		RETAINER - FRONT BRG - CHRYS. CAR, 308 BRG. 23 SPL. INPUT, 5-1/8" O.D. - CAST #13157
1	14039085	C15397	RETAINER - FRONT BRG - CHEVY TRUCK - ALL
2	N.A.		BOLT - FRONT RETAINER
3	2801893		GASKET - FRONT RETAINER
4	9487		SEAL - INPUT, CHRYS - 18 SPL. INPUT
4	9376		SEAL - INPUT, CHRYS - 23 SPL. INPUT
4	74125		SEAL - INPUT, CHEVY TRUCK - ALL
5	307L		BEARING - INPUT, CHRYS. 18 SPL. - ALL, 23 SPL - VARIOUS
5	308LOE		BEARING - INPUT, CHRYS. 23 SPL - VARIOUS CHEVY TRUCK - ALL
6	4058673		GASKET - SHIFT HOUSING
7	CALL		MAIN CASE - CALL - CAST# AND APPLICATION
8	1139153		PLUG - FILL
9	WT294-16		INPUT - CHRYS. CAR 24T, NON-O.D.
9	WT294-16A	2466427	INPUT - CHRYS. CAR 22T, NON-O.D. - 6 CYL. SM. V8 - 11.25" O.A.
9	WT294-16B	2538698	INPUT - CHRYS. CAR 21T, 426/440 V8 - 64-70 - 18 SPL. 11.25" O.A.
9	WT294-16C	3410409	INPUT - CHRYS. CAR 25T - 11.25" V8
9	WT294-16D	3410402	INPUT - CHRYS. CAR 22T, NON-O.D. - 426/440 V8 - 18 SPL. 11.25" O.A.
9	2801427		INPUT - CHRYS. CAR - RACE 21T, 426/440 V8 NON-SYNCHRO, 11.25" O.A.
9	2892320		INPUT - CHRYS. CAR - RACE 21T, 426/440 V8 NON-SYNCHRO - 18 SPL. 11.25 O.A.
9	T833-16E	3878647	INPUT - CHRYS. CAR 24T - O.D. 11.25" O.A.
9	T833-16F	3742690	INPUT - CHRYS. CAR/TRUCK 22T - O.D. 11.25" O.A.
9	T833-16H	14039072	INPUT - CHEVY TRUCK 22T - O.D.
10	ABRZ3549		NEEDLE BEARING - INPUT POCKET
11	6024130		SNAP RING
12	3410204		SPRING - INTERLOCK
13			FORK LEVER 3-4
14	3410038		FORK 3-4 - SCISSOR INTERLOCK
14	2466961		FORK 3-4 - BALL-SLEEVE INTERLOCK
15	3410141		FORK 1-2 - SCISSOR INTERLOCK
15	2538421		FORK 1-2 - BALL-SLEEVE INTERLOCK
16	2464051		FORK - REV.
17	1635293		RETAINER - REV. IDLER SHAFT
18	WT294-35	2464023	SHAFT - REV. IDLER
19	AWT294-10	2464073	REVERSE IDLER GEAR - ALL TO 1977 - 22T
19	AT833-10A	4058691	REVERSE IDLER GEAR - ALL 1978-ON
19	AT833-10B	14053366	REVERSE IDLER - 22T - GM GAS
19	AT833-10C	14053370	REVERSE IDLER - 22T - GM DIESEL
20	CALL WITH APPLICATION		LEVER ASSY - REVERSE - 22T
21	313156		SHIFT SHAFT SEAL
22			LEVER ASSY 1-2
23	1316849		SHIFT SHAFT SEAL
24	4295110		CONTROL HOUSING - ALL
25	2464743		WASHER, COUNTERSHAFT NEEDLE BRGS
26/28	G437Q		NEEDLE BEARING, C/S (76 REQ.)
27	WT294-8A	2464658	CLUSTER GEAR, CHRYS. CAR 6 CYL., 273-318 - 3.09 RATIO 8 CYL. 33-29-25-17-17
27	WT294-8B	2538195	CLUSTER GEAR, CHRYS. CAR 426, 440 V8 - 2.65 RATIO, 27-24-23-17-17
27	WT294-8C	2801109	CLUSTER GEAR, CHRYSLER CAR 426, 440 V8 - 2.81 RATIO, 27-24-20-17-16
27	WT294-8E	3410407	CLUSTER GEAR, CHRYS. CAR 426, 440 V8 - 2.59 RATIO, 26-23-20-17-16
27	WT294-8	2801109	CLUSTER GEAR, CHRYSLER CAR - ALL OTHER 8 CYL., 2.66 RATIO, 31-27-23-17-17
27	WT294-8D	3410412	CLUSTER GEAR, CHRYS. CAR - ALL OTHER 8 CYL., 2.47 RATIO, 30-26-23-17-17

A833 - NP440 - MY6 STYLE (cont.)

ILL #	MIDWEST #	REF#	REPLACEMENT PART DESCRIPTION
27	97261	2801033	CLUSTER GEAR, CHRYS. CAR 426-440 8 CYL. RACE- 2.65 RATIO 27-24-20-17-16
27	97696	2892327	CLUSTER GEAR, CHRYS. CAR 426-440 8 CYL. RACE- 2.65 RATIO 27-24-22-17-16
27	11579	3681315	CLUSTER GEAR, CHRYS. CAR 426-440 8 CYL. RACE- 2.65 RATIO 27-26-22-17-16
27	T833-8F	3878651	CLUSTER GEAR, CHRYS. CAR - O.D., 3.09 RATIO, 36-42-27-17-17
27	T833-8G	3878432	CLUSTER GEAR, CHRYS. CAR/TRUCK - O.D.- 3.09 RATIO 33-37-27-17-17
27	T833-8H	14053367	CLUSTER GEAR, CHEVY TRUCK - GAS 33-37-27-17-17 ALUM. CASE
27	T833-8J	14053371	CLUSTER GEAR, CHEVY TRUCK - DIESEL 33-37-27-17-17, IRON CASE
30	4028123		COUNTERSHAFT - ALUM. CASE
30	WT294-3		COUNTER SHAFT - IRON CASE
31	1635293		KEY - COUNTERSHAFT
33	AWT294-2.5A	3515469	SYNCHRO ASSY 3-4, CHRYS. CAR - NARROW KEYS - 40 SPL.
33	AWT307-2.5A	4130096	SYNCHRO ASSY 3-4, CHRYS. CAR - WIDE KEYS - w/o O.D.
33	AT833-2.5B	4130094	SYNCHRO ASSY 3-4, CHRYS. CAR/TRUCK, CHEVY TRK - O.D.
33	97282	2801428	HUB & SLEEVE 3-4, CHRYS. CAR, NON-SYNCHRO - 18 SPL.
34/32	WT294-14	2801381	SYNCHRO RING - CHRYS. NARROW KEYS 1, 2, 3, 4
35	WT294-11A	2464659	3RD GEAR, M/S CHRYS. CAR 6 CYL. 273-318 8 CYL., 27T
35	WT294-11C	2538699	3RD GEAR, M/S CHRYS. CAR 426-440 V8, 26T (USE 8B OR 8C CLUSTER)
35	WT294-11E	3410405	3RD GEAR, M/S CHRYS. CAR 426-440 V8, 26T (USE 8E CLUSTER)
35	WT294-11	2464016	3RD GEAR, M/S CHRYS. CAR - ALL OTHER 8 CYL., 29T (USE 294-8 CLUSTER)
35	WT294-11D	3410410	3RD GEAR, M/S CHRYS. CAR - ALL OTHER 8 CYL., 29T (USE 294-8D CLUSTER)
35	97279	2801434	3RD GEAR, M/S CHRYS. CAR 426-440 V8 SYNCHRO 26T (USE 97261 CLUSTER)
35	97699	2892321	3RD GEAR, M/S CHRYS. CAR 426-440 V8 NON-SYNCHRO 26T (USE 97696 CLUSTER)
35	11575	3681311	3RD GEAR, M/S CHRYS. CAR 426-440 V8 NON-SYNCHRO 24T (USE 11579 CLUSTER)
35	T833-11F	3878648	4TH GEAR O.D., M/S CHRYS. CAR 20T
35	T833-11G	3878430	4TH GEAR O.D., M/S CHRYS. CAR/TRUCK, CHEVY TRUCK 19T
36	WT294-2	2464035	MAIN SHAFT CHRYS. CAR - FULL SIZE 27-3/8", 40-40-23
36	WT294-2A	2464169	MAIN SHAFT CHRYS. CAR MID-SIZE, COMPACT 21-3/4", 40-40-23
36	WT294-2B	2891942	MAIN SHAFT CHRYS. CAR FULL SIZE, BARRACUDA 27-1/2", 40-40-30
36	WT294-2C	2466920	MAIN SHAFT CHRYS. CAR MID-SIZE, COMPACT 23-1/4", 40-40-26
36	WT294-2D	2892909	MAIN SHAFT CHRYS. CAR MID-SIZE, COMPACT 23-1/4", 40-40-30
36	4058228	T833-2G	MAIN SHAFT CHRYS. CAR O.D., 23-1/4" 32-40-26
36	T833-2F		MAIN SHAFT CHRYS. TRUCK, 27-3/8", 32-40-30
36	T833-2J	14039079	MAIN SHAFT CHEVY TRUCK, 21-1/8", 32-40-27 - 2WD
36	T833-2K	14053374	MAIN SHAFT CHEVY TRUCK, 19-11/16", 32-40-32, 4X4
37	WT294-21A	2464069	2ND GEAR M/S CHRYS. CAR, 6 CYL., 273-318 8 CYL. 32T
37	WT294-21B	2538075	2ND GEAR M/S CHRYS. CAR, 426-440 V8, 30T (USE 294-8B CLUSTER)
37	WT294-21E	3410403	2ND GEAR M/S CHRYSLER CAR, 426-440 V8, 30T (USE 294-8E CLUSTER)
37	WT294-21	2464017	2ND GEAR M/S CHRYS. CAR - ALL OTHER 8 CYL. 34T (USE 294-8 CLUSTER)
37	WT294-21D	3410411	2ND GEAR M/S CHRYS. CAR - ALL OTHER 8 CYL. 34T (USE 294-8D CLUSTER)
37	97278	2801436	2ND GEAR M/S CHRYS. CAR 426-440 V8, NON-SYNCHRO 30T (USE 97261 CLUSTER)
37	97698	2892323	2ND GEAR M/S CHRYSLER CAR, 426-440 V8, NON-SYNCHRO 30T (USE 97696 CLUSTER)
37	11577	3681313	2ND GEAR M/S CHRYS. CAR, 426-440 V8, NON-SYNCHRO 28T (USE 11579 CLUSTER)
37	T833-21F	3878649	2ND GEAR M/S CHRYS. CAR, O.D., 30T FINE PITCH (USE 3878651 CLUSTER)
37	T833-21G	3878431	2ND GEAR M/S CHRYS. CAR/TRUCK, CHEVY TRUCK O.D., 30T, COURSE PITCH (USE 3878432 CLUSTER)
39	AWT294-80A	3515470	SYNCHRO ASSY 1-2, M/S REV. GEAR, CHRYS. CAR, NARROW KEYS
39	AWT294-80C	3515446	SYNCHRO ASSY 1-2, M/S REV. GEAR, CHRYS. CAR/TRUCK, WIDE KEYS
39	97281	2801431	HUB & SLEEVE 1-2, M/S REV. GEAR, CHRYS. CAR-RACE 18 SPL.

A833 - NP440 - MY6 STYLE (cont.)

ILL #	MIDWEST #	REF#	REPLACEMENT PART DESCRIPTION
39	AT833-80D		SYNCHRO ASSY 1-2, M/S REV. GEAR, CHEVY TRUCK - GAS
39	AT833-80E		SYNCHRO ASSY 1-2, M/S REV. GEAR, CHEVY TRUCK-DIESEL
40/38	WT307-14	3515023	SYNCHRO RING - CHRYS. WIDE KEYS, CHEVY - ALL 1-2-3-4
41	WT294-12	2464018	1ST GEAR M/S CHRYS. CAR/TRUCK ,(EXC. BELOW), CHEVY TRUCK, ALL, 35T
41	WT294-12A	2801107	1ST GEAR M/S CHRYS. CAR 426-440 V8 - BUSHING, 35T
41	T833-12B	3878650	1ST GEAR M/S CHRYS. CAR - O.D., FINE PITCH 35T
41	97277	2801438	1ST GEAR M/S CHRYS. CAR 426-440 V8 RACE - BUSHING 33T
42	N.S.S.		SNAP RING - INCLUDED - BRG.
43	308LOE		BEARING, M/S REAR, CHRYS. TRUCK/CHEVY TRUCK, CHRYS. CAR, 30 SPL.
43	307L		BEARING, M/S REAR, CHRYS. CAR, 26 SPL.
44	2464059		GASKET - EXTENSION HOUSING
45			EXTENSION HOUSING - CALL - APPLICATION
46	2801724		BUSHING - CHRYS. CAR - 26 SPL. 1-9/16" I.D.
46	2801726		BUSHING - CHRYS. CAR/TRUCK - 30 SPL. 1-11/16" I.D.
46	6260048		BUSHING - CHEVY TRUCK - ALL
47	81605		SEAL, M/S REAR - CHRYS. CAR, 23 SPL.
47	2506		SEAL, M/S REAR - CHRYS. CAR, 26 SPL.
47	73005		SEAL, M/S REAR - CHRYS. TRUCK - ALL
47	96135		SEAL, M/S REAR - CHEVY TRUCK - ALL

KITS

T833R	→	BEARING GASKET & SEAL KIT - CHRYS/CHEVY TRUCK, O.D.
T833RMK	→	BEARING GASKET & SEAL MASTER KIT - SMALL PARTS & SYNCHRO RINGS
T833RA	→	BEARING GASKET & SEAL KIT - CHRYS. CAR NON-O.D., IRON CASE
T833RAMK	→	BEARING GASKET & SEAL MASTER KIT - SMALL PARTS & SYNCHRO RINGS
T833RB	→	BEARING GASKET & SEAL KIT - CHRYS. CAR - O.D. IRON OR ALUM.
T833RBMK	→	BEARING GASKET & SEAL MASTER KIT - SMALL PARTS & SYNCHRO RINGS
K833	→	GASKET & SEAL KIT - ALL
SP294-50	→	SMALL PARTS KIT - ALL

M21/M22 STYLE MUNCIE® 4 SPEED CAR

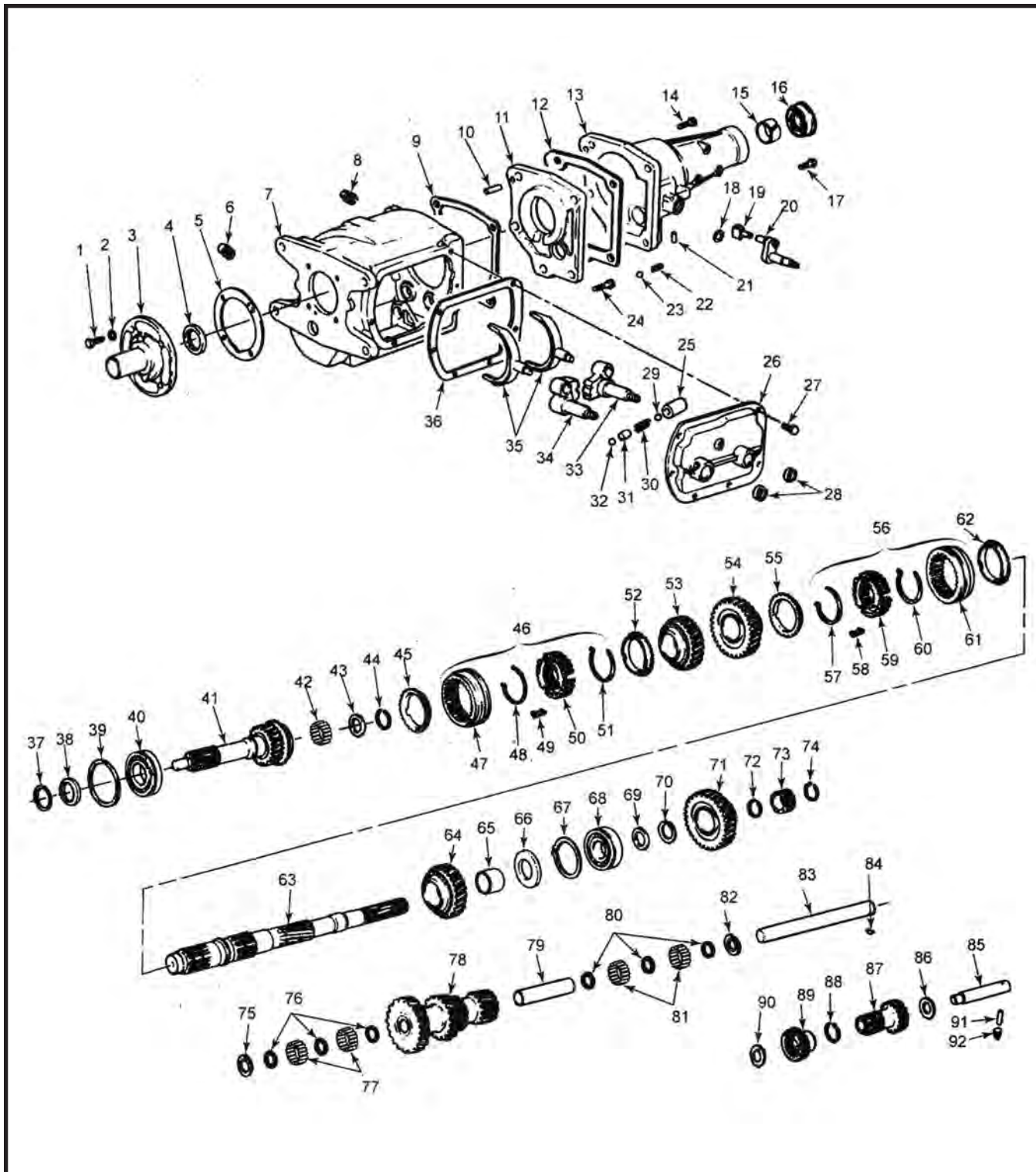

M21/M22 STYLE (cont.)

ILL #	MIDWEST #	REF #	REPLACEMENT PART DESCRIPTION
3	WT297-6	3915020	FRONT BEARING RETAINER
7	WT297-1		MAIN CASE 7/8" PIN
7	WT297-1A		MAIN CASE 1" PIN
8/6	N.A.		CASE PLUG - 1/2" N.P.T.
11	WT297-7		REAR BEARING RETAINER, MID-PLATE
13	CALL w/ APPLICATIONS AND CASTING #		REAR EXTENSION HOUSING
15	WT266-62	6260048	BUSHING - REAR OUTPUT - SMALL 27 SPL.
15	WT297-62	3978765	BUSHING - REAR OUTPUT - LARGE 32 SPL.
16	9613S		OUTPUT SEAL - 27 SPL.
16	9449		OUTPUT SEAL - 32 SPL.
18	240735	3044036	SEAL - REV. SHIFT SHAFT
19		3832786	FORK - REV. SHIFT
20		3850086	LEVER - REV. SHIFT
28	240735	3831716	SEAL - SHIFT SHAFT 1-2 AND 3-4
34		3831709	LEVER ASSY - 1-2 AND 3-4 SHIFT - 1963-68
34		3950308	LEVER ASSY - 1-2 AND 3-4 SHIFT - 1969
34		3952649	LEVER ASSY - 1-2 AND 3-4 SHIFT - 1970-74
35	WT297-23	3831717	SHIFT FORK 1-2 AND 3-4
40	N307LOE		INPUT BEARING
40	N1307L		INPUT BEARING - HEAVY DUTY
41	AWT297-16	3925690	INPUT - 10 SPL CLOSE RATIO - 26T - (1) I.D. GROOVE
41	AWT297-16A	3924781	INPUT - 10 SPL WIDE RATIO 1963-65 - 24T - NO I.D. GROOVE
41	AWT297-16B	3925689	INPUT - 10 SPL WIDE RATIO 1966-70 - 21T - (2) I.D. GROOVES
41	AWT297-16C	3978772	INPUT - 26 SPL WIDE RATIO 1971-74 - 21T - (2) I.D. GROOVES
41	AWT297-16D	3978773	INPUT - 26 SPL CLOSE RATIO 1971-74 - 26T - (1) I.D. GROOVE
41	AWT297-16U	3925691	INPUT - 10 SPL CLOSE RATIO 1966-74 M22HD- 26T- NO GROOVES
42	JV441419		POCKET BEARING CAGE w/NEEDLES
43	C417Q		NEEDLE BEARING M/S PILOT (17 REQ.)
45	WT297-14		SYNCHRO RING - EARLY - NO STEP 36T
45	WT297-14A		SYNCHRO RING - LATE - STEP ON O.D. 36T
45	WT297-14B		SAME AS ABOVE
46	AWT297-2.5A	3924113	SYNCHRO ASSY 3-4 w/ RINGS
47/61	T85B-15		SYNCHRO SLEEVE 1-2 AND 3-4 NON-TORQUE LOCK
47/61	T10-15		SYNCHRO SLEEVE 1-2 AND 3-4 - TORQUE LOCK
48	SEE ITEM #51		
49/58	WT297-77	3915050	SYNCHRO KEY
50	WT297-2.5		SYNCHRO HUB - ALL
51/57/60	WT297-78	3920775	SYNCHRO SPRING
52	SEE ITEM #45		
53	WT297-11	3831747	3RD GEAR 27T - ALL EXC. M22HD
53	WT297-11A	3880845	3RD GEAR 27T - M22HD
54	WT297-21	3831746	2ND GEAR M/S - 30T - ALL EXC. M22HD
54	WT297-21A	3879999	2ND GEAR M/S - 30T - M22HD
55	SEE ITEM #45		
56	AWT297-80A	3924112	SYNCHRO ASSY 1-2 w/ RINGS
62	SEE ITEM #45		
63	WT297-2	3831753	MAIN SHAFT 27 SPL - 21-1/8" O.A.
63	AWT297-2A	3915087	MAIN SHAFT 27 SPL - 1963-70 EXC PONTIAC - 21-1/8" O.A.
63	WT297-2D	388838	MAIN SHAFT 27 SPL - 1963-70 PONTIAC - 27-1/2" O.A.
63	WT297-2B	3979759	MAIN SHAFT 32 SPL
64	WT297-12	3831743	1ST GEAR 36T - 1963 ONLY
64	WT297-12A	3849388	1ST GEAR 36T - 1964-74 - ALL EXC. M22HD
64	WT297-12B	3924796	1ST GEAR 36T - 1964-74 - M22HD
65	WT297-19A	3978781	BUSHING - 1ST GEAR
68	308L		REAR BEARING M/S
71	WT297-36	3831748	REV. GEAR M/S - 35T
75		3831729	THRUST WASHER COUNTERSHAFT - 1963-65
75		3864860	THRUST WASHER COUNTERSHAFT - 1966-74
76/80	3709324		SPACER WASHER COUNTERSHAFT NEEDLES - 1963-65 (6 REQ.)

M21/M22 STYLE (cont.)

ILL #	MIDWEST #	REF #	REPLACEMENT PART DESCRIPTION
76/80	3864856		SPACER WASHER COUNTERSHAFT NEEDLES - 1966-74 (6 REQ.)
77/81	S443Q	3209328	NEEDLE BEARING COUNTERSHAFT - 1963-65 (80 REQ.)
77/81	C407Q	435847	NEEDLE BEARING COUNTERSHAFT - 1966-74 (112 REQ.)
78	WT297-8	3831727	CLUSTER GEAR 1963-65 - 7/8" PIN CLOSE RATIO 2.20, 27-22-19-17
78	AWT297-8A	3831728	CLUSTER GEAR 1963-65 -7/8" PIN WIDE RATIO 2.56 - 29-22-19-17
78	AWT297-8C	3905463	CLUSTER GEAR 1966-74 -1" PIN WIDE RATIO 2.52 - 25-22-19-17
78	AWT297-8D	3905465	CLUSTER GEAR 1966-74 -1" PIN CLOSE RATIO 2.20 - 27-22-19-17
78	WT297-8E	3905466	CLUSTER GEAR 1966-74 -1" PIN CLOSE RATIO 2.20 TO "ROCK CRUSHER" M22 HD LOW HELIX 27-22-19-17
79		3912195	SPACER TUBE - COUNTERSHAFT
83	WT297-3	3831725	COUNTERSHAFT 1963-65 - 7/8" O.D.
83	WT297-3A	3864850	COUNTERSHAFT 1966-74 - 1" O.D.
85	WT297-35	3831761	SHAFT - REV. IDLER GEAR
86	3774909		THRUST WASHER - REV. IDLER - REAR
87	AWT297-10A	3831764	REV. IDLER GEAR - BUSHINGS 17T/27 SPL
89	WT297-10		REV. IDLER - FRONT - ALL EXC. M22HD
89	WT297-10B		REV. IDLER - FRONT - M22HD
90	3834739		THRUST WASHER - REV. IDLER - FRONT
N.I.	WT297-90		INPUT NUT

KITS

T297R	➔	BEARING & SEAL KIT - GM MUNCIE
T297RA	➔	BEARING & SEAL KIT - 207 INPUT - 1963-64
T297RAMK	➔	BEARING & SEAL MASTER KIT GM MUNCIE' - 1" COUNTER
T297RAHDMK	➔	BEARING & SEAL MASTER KIT - 1" COUNTER MAXI-TYPE BEARINGS - 1966-74
T297RHD	➔	MUNCIE M20, 21, 22 w/ MAXI-TYPE BEARING
T297RHDMK	➔	BEARING & SEAL MASTER KIT-7/8" COUNTER MAXI-TYPE BEARINGS-1963-65
T297RMK	➔	BEARING & SEAL KIT - GM MUNCIE - 7/8" COUNTER
GK-M22	➔	M22 GEAR KIT - 10 SPLINE
GK-M22-26	➔	M22 GEAR KIT - 26 SPLINE
GS297-55	➔	GASKET SET
K297	➔	GASKET/SEAL KIT
SP297-50	➔	SMALL C/S BORE - 1963-65
SP297-50A	➔	LARGE C/S BORE - 1966-74
WT297K	➔	KEY/SPRING KIT

NP435 STYLE FORD® PICK-UP 1974-87

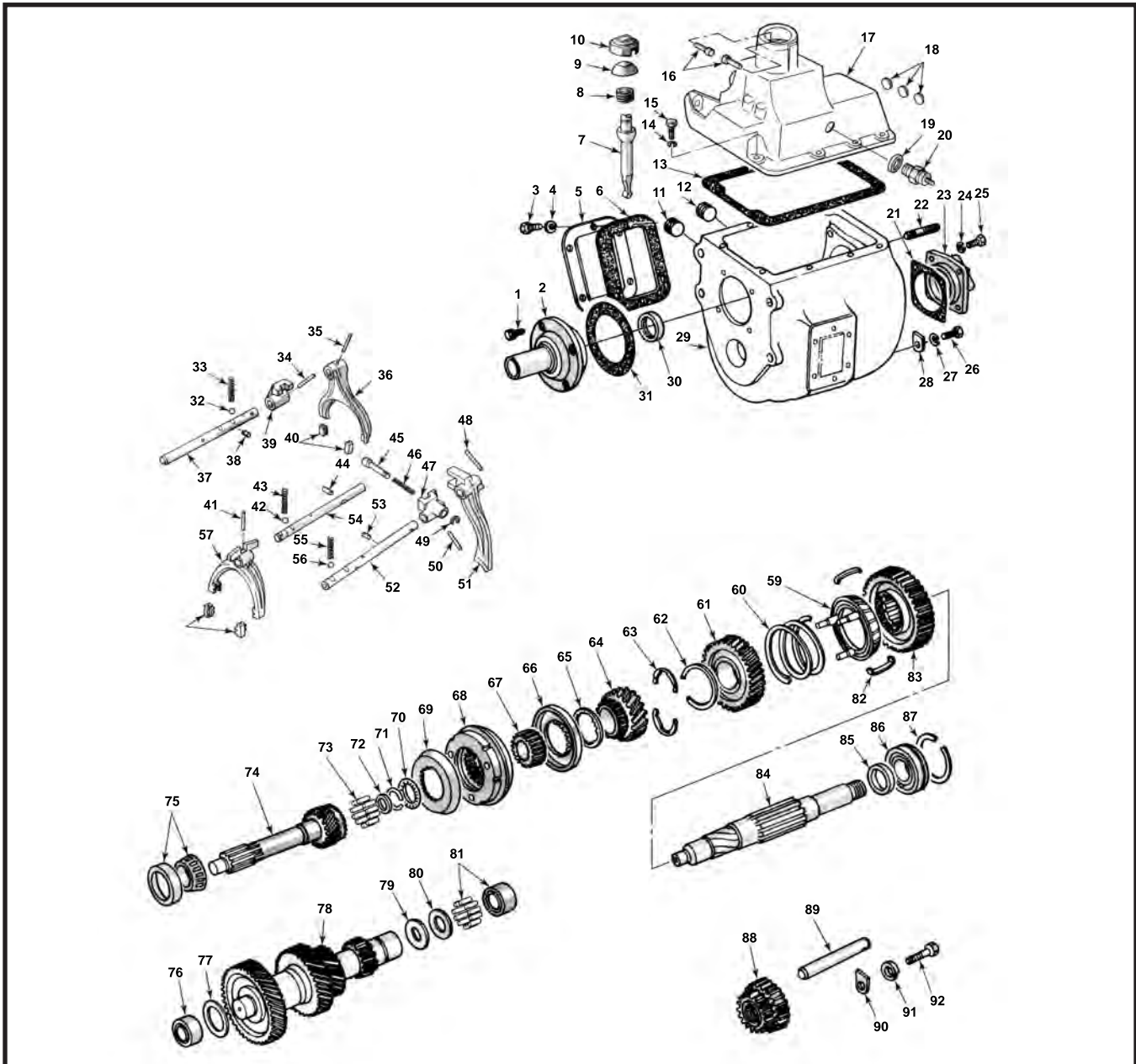

ILL #	MIDWEST #	REF #	REPLACEMENT PART DESCRIPTION
1	N/A		BOLT, FRONT RETAINER
2	WT291-6	96384	RETAINER, FRONT BEARING - 4-31/64" O.A. FORD
2	WT291-6A	95724	RETAINER, FRONT BEARING - 4-11/32" O.A. FORD, CAST (95723)
2	WT291-6B	96373	RETAINER, FRONT BEARING 5-1/8" O.A.
2	17095	96003	RETAINER, FRONT BEARING 1-1/8" SPLINE GM*
2	WT291-6E		RETAINER, FRONT BEARING 1-1/2" SPLINE GM
2	WT291-6G	96464	RETAINER, FRONT BEARING - 10 SPL. TAPERED BRG. INPUT CAST (95767)
2	WT291-6H	97552	RETAINER, FRONT BEARING - 23 SPL. TAPERED BRG. INPUT
2	4340264		RETAINER FRONT BEARING 1988-ON DODGE*
3/4	N/A		BOLT/WASHER, PTO COVER
5	NV35662	556875	COVER, PTO
7	11306		SHIFT LEVER, 3-3/4" LONG
8	1936219		SPRING, SHIFT LEVER
9	1936218		CUP, SHIFT LEVER
10	1936220		RETAINER, SHIFT LEVER
11/12	N/A		PLUG, FILL/DRAIN

NP435 STYLE (cont.)

ILL #	MIDWEST #	REF #	REPLACEMENT PART DESCRIPTION
15/14	1673185		SCREW - WASHER, TOP COVER
16	3633461		PIN, SHIFT LEVER
17	A211351		COVER - 6-1/4" LONG - FORD*
17	A211352		COVER - 8-5/8" LONG - FORD
17	CALL FOR MORE APPLICATIONS		COVER, VARIOUS (USED AVAILABLE UPON REQUEST)
18	142656		PLUG, TOP COVER
19	NV89279	1302807	GASKET, BACKUP LIGHT SWITCH
20	N/A		BACKUP LIGHT SWITCH
22	N/A		STUD
23	WT291-7	95734	RETAINER, C/S REAR
25/24	167185		SCREW - WASHER, C/S RETAINER
27/26	N/A		BOLT/WASHER, RETAINER PLATE
28	1266009		RETAINER PLATE, REV. IDLER SHAFT
29	3641882		MAIN CASE 1982-86 DODGE* TRUCK
29	95711		MAIN CASE FORD* OFFSET BOLT PATTERN (#C95711)
29	96391		MAIN CASE FORD (#C96391)
30	482163N	4167917	SEAL, INPUT (TAPERED BRG.)
30	7412S		SEAL, INPUT 1-1/8" SPL. (BALL BRG.)
30	470380		SEAL, INPUT 1-1/2" SPL. (BALL BRG.)
31/21/13/6	GS291-55		GASKET SET
34	NV18437	4741362	ROLL PIN, FORK
36	WT291-22	96971	FORK, 1-2
37	WT291-20	95742	RAIL, 102 FORK
38	NV35660	2462228	PLUNGER, SHIFT INTERLOCK
39	WT291-24	95739	LUG, 1-2 RAIL
40	WT291-23	96969	FORK INSERTS 1-2
41/35	NV18437	4741362	ROLL PIN, FORK
44	NV88397	1265694	PIN, SHIFT INTERLOCK
45	1500335	89923	PLUNGER, REV. LUG
46	567499		SPRING, REV. LUG PLUNGER
47	WT291-24A	94021	LUG, REV. RAIL
49	313514		LOCK RING, REV. PLUNGER
50/48	NV18437		ROLL PIN, FORK
51	WT291-22A	95738	FORK, REV.
52	WT291-20B	97238	RAIL, REV. FORK
53	NV35660	2462228	PLUNGER, SHIFT INTERLOCK
54	WT291-20A	99529	RAIL, 3-4 FORK
55/43/33	1409551	89791	SPRING, POPPET BALL
56/42/32	1300109003	453593	POPPET BALL
57	WT291-22B	95747	FORK, 3-4
58	WT291-23A	93549	FORK INSERTS 3-4
59	AWT291-83	95727	STOP RING, 2ND GEAR - PINS
60	2507842	95729	SPRING, 2ND GEAR SYNCHRO
61	WT291-21	95726	2ND GEAR, M/S 33T
61	WT291-21B	96916	2ND GEAR, M/S 32T
62	2507843		SNAP RING, 2ND GEAR
63	1664321	91726	SPLIT WASHER, 2ND GEAR
64	WT291-11	95708	3RD GEAR M/S 23T
64	WT291-11B	96914	3RD GEAR M/S 25T
64	T435-11C	13528	3RD GEAR M/S 24T
65	69241B		SHIM, 3-4 SYNCHRO
67	WT291-2.5	95849	HUB, 3-4 SYNCHRO - BALL INPUT BRG.
67	AWT291-2.5B	96986	HUB, 3-4 SYNCHRO - TAPERED INPUT BRG.
68	WT275-2.5B	11337	SYNCHRO ASSY 3-4 - HUB & SLIDER ONLY
68	AWT291-2.5D	11562	SYNCHRO ASSY 3-4 (USE TAPERED INP. BRG.) HUB & SLIDER
68	WT291-2.5	95849	SYNCHRO ASSY 3-4 (USE BALL INP. BRG.) HUB & SLIDER
68	WT275-14	92197	SYNCHRO RING (ALUMINUM)
69	WT258-14	11334	STOP RING, 3-4 SYNCHRO - STEEL
70	FA35688	2826115	THRUST BEARING, M/S
71	1664329	91484	SNAP RING, M/S PILOT BRG.
72	2507826	95702	WASHER, M/S PILOT BRG.
73	Q15902	1664327	NEEDLE BEARING, M/S PILOT (14 REQ.)
74	WT291-16	2507814	INPUT - CHRYSLER* (D400-D700) 11-11/16" O.A. 17T, 1-3/8" SPL. DIAM.
74	WT291-16A	2508021	INPUT - CHRYS. (D100-D300) 12-1/16" O.A., 17T, 1" SPL. DIAM.
74	WT291-16B	96004	INPUT - GM* BALL BRG. 9-1/8" O.A., 17T
74	WT291-16C	95723	INPUT - FORD (F500-F750) - 9-5/16" O.A., 17T
74	WT291-16E	96354	INPUT - GM* BALL BRG., 10-5/32" O.A., 17T
74	WT291-16F	96362	INPUT - GM BALL BRG. - SEAL, 9-1/4" O.A., 17T

NP435 STYLE (cont.)

ILL #	MIDWEST #	REF #	REPLACEMENT PART DESCRIPTION
74	WT291-16H	96372	INPUT - FORD (350-500) 10-1/16" O.A., 17T
74	WT291-16J	96383	INPUT - FORD/GM (F100-F350), 9-1/8" O.A., 17T, (F100-F350)
74	WT291-16K	95957	INPUT - GM TAPERED BRG. 9-1/8" O.A., 22T
74	WT291-16G	2513844	INPUT - CHRYSLER 12-1/16" O.A., 22T
74	WT291-16L	95993	INPUT - IHC 12-7/16" O.A., 17T
74	WT291-16M	96716	INPUT - IHC 12-15/16" O.A., 17T, 1-1/4" SPL. DIAM.
74	WT291-16Q	97672	INPUT - DODGE 10-7/8" O.A., 17T
74	WT291-16R	97193	INPUT - DODGE 11-11/16" O.A., 17T
74	WT291-16U		INPUT - INDUSTRIAL 10-3/4" O.A., 17T, 1-3/8" SPL. DIAM.
74	WT291-16W		INPUT 17T 9-1/8" O.A. GM TAPERED BRG.
75	HM88649 / HM88610		BEARING, INPUT - TAPERED
75	1308L		BEARING, INPUT - BALL
76	BCE2416	4117651	BEARING, C/S FRONT
77	2507995	95713	THRUST WASHER, FRONT C/S BRG.
78	WT291-3	95733	CLUSTER GEAR 43-35-25-14
78	T435-8D	13527	CLUSTER GEAR 43-34-25-14
79	NTA2031	2507996	THRUST BEARING, C/S REAR
80	2507997	95716	THRUST RACE, C/S REAR
81	B3216	2225014	BEARING, C/S REAR
82	2829823	97042	SPRING, LOW SLIDER
83	WT291-12	95732	1ST/REV. GEAR M/S 37T
84	WT291-2	2507825	MAIN SHAFT 13-5/8" - GM 35-10, 35 SPL.
84	AWT291-2B	95947	MAIN SHAFT 13-1/3" - FORD/GM 35-10, 35 SPL.
84	WT291-2D	95991	MAIN SHAFT 13-5/8" - IHC 35-10, 10 SPL.
84	WT291-2E	97478	MAIN SHAFT 16-3/4" - FORD 35-10, 28 SPL.
84	WT291-2F	97898	MAIN SHAFT 17-3/8" - DODGE 35-10, 23 SPL.
84	WT291-2G	13082	MAIN SHAFT 16-3/4" - GM 35-10, 32 SPL.
84	WT291-2K	13288	MAIN SHAFT 19-1/2" - UPS 35-10, 32 SPL.
84	WT291-2L	13907	MAIN SHAFT
84	T435-2H	11957	MAIN SHAFT 19-1/2" - 23 SPL., 4X4 DODGE - DIRECT DRIVE T/C
84	T435-2J	13185	MAIN SHAFT 19-5/32" - 31 SPL.
84	4340266		MAIN SHAFT 17-5/32" - 2WD LATE DODGE - BALL BEARING, INPUT
84	4340267		MAIN SHAFT 17-5/8" - 4WD LATE DODGE - TAPERED BEARING, INPUT
84	WT291-2N	E3TZ7061D	MAIN SHAFT 24-5/16" - FORD
85	2507844	96187	SPACER, M/S REAR
86	1308L		BEARING, M/S REAR
87	4745E	15619307	SNAP RING, REAR BRG.
88	AWT291-10B	99531	REVERSE IDLER GEAR - BEARING (21T)
88	AWT291-10C	95979	REVERSE IDLER GEAR - BUSHING (21T)
89	WT258-35A.		REV. IDLER GEAR SHAFT
N.I.	WT291-62		BUSHING, LARGE FORD
N.I.	NV18693		NUT - M/S REAR
N.I.	WT259-62		SMALL BUSHING

KITS

T127R	➔	BEARING, GASKET & SEAL KIT (TAPERED INPUT)
T127GR	➔	BEARING, GASKET & SEAL KIT (BALL INPUT)
T127RS	➔	BEARING KIT - SMALL PARTS KIT AND FORK INSERTS
T127GRS	➔	BEARING KIT - SMALL PARTS KIT AND FORK INSERTS
T127RMK	➔	BEARING KIT - SMALL PARTS, SYNCHRO RINGS, FORK PADS
T127GRMK	➔	BEARING KIT - SMALL PARTS, SYNCHRO RINGS, FORK PADS
SP291-50	➔	SMALL PARTS KIT
GS291-55	➔	GASKET KIT
K127	➔	GASKET & SEAL KIT

NV1500 STYLE CHEVY® S10 - 1996 & UP 4 CYL.

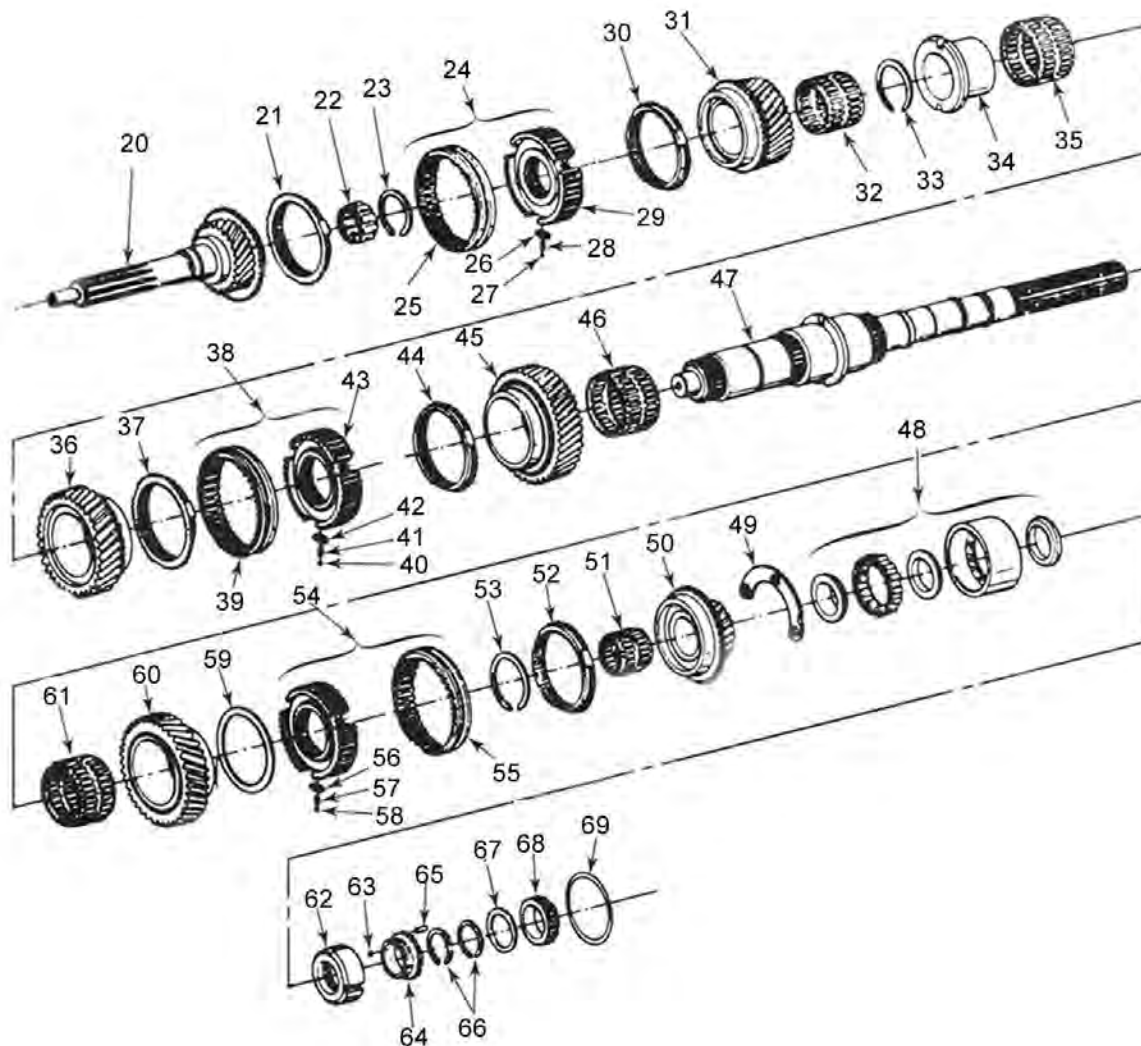
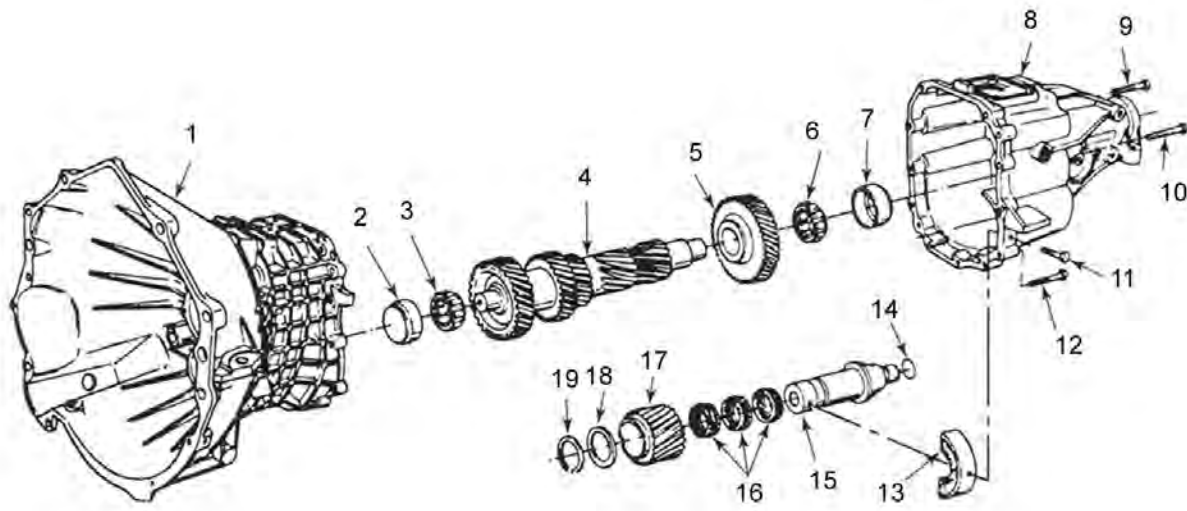

NV1500 STYLE (cont.)

ILL #	MIDWEST #	REF #	REPLACEMENT PART DESCRIPTION
1	NV22349		CASE ASSY - FRONT HALF
3	FC68336	NV22346	BEARING, COUNTERSHAFT FRONT
4	NV22346	12382734	COUNTERSHAFT ASSY - ALL
5	NV20637	12382735	5TH GEAR, COUNTERSHAFT
6	206L	NV20534	BEARING, COUNTERSHAFT REAR
6	NV21402	12382732	FRONT BEARING RETAINER
7	WT266-62		BUSHING
8	NV20301	12549380	CASE ASSY - REAR HALF
13	NV26065		COLLAR, REVERSE IDLER SHAFT
14	NV23499	12382772	O-RING, REVERSE IDLER SHAFT (2 REQ.)
15	NV20653	12382737	SHAFT, REVERSE IDLER
17	NV20638	12382739	REVERSE IDLER GEAR - ALL
20	NV20632	12549428	INPUT SHAFT ASSY - ALL
22	NV23941	12382868	NEEDLE BEARING, INPUT POCKET
23	NV21384	12549388	SHIFT FORK 1-2
23A	NV28886	12549387	SHIFT FORK 3-4
23B	NV21382	12549386	SHIFT FORK 5-REV.
24	NV23186	12382768	SYNCHRO ASSY 3-4
26	NV20573	12549411	SYNCHRO KEY - ALL
28	NV20572	12549416	SYNCHRO SPRING - ALL
31	NV26453	12382858	3RD GEAR, MAIN SHAFT
33	NV21433	12549404	RETAINER, REAR BEARING
36	NV25670	12382850	2ND GEAR, MAIN SHAFT
37	NV20950	12549405	SYNCHRO RING 1-2 OUTER, 3-4-5
38	NV23186	12382766	SYNCHRO ASSY, 5-REV.
38	NV21553	12549415	SYNCHRO ASSY 1-2
45	NV21385	12549414	1ST GEAR, MAIN SHAFT
47	NV21442	12549399	MAIN SHAFT - ALL
48	306L	NV20526	BEARING, M/S REAR
50	NV24994	12382797	5TH GEAR, MAIN SHAFT
54	NV22337	12549389	SHIFT SHAFT
60	NV24799	12382794	REVERSE GEAR, M/S
60	NV23326	12382770	SOCKET - SHIFT SHAFT
68	NV20510	12549400	SPEEDO RING, MAGNETIC
75	NV21008	12549329	SEAL - MAIN SHAFT
76	NV18127	8672236	BUSHING - MAIN SHAFT
91	NV21042	12382733	SEAL, INPUT
96	306L		BEARING, INPUT
N.I.	NV21559	12549417	SYNCHRO RING, CENTER 1-2
N.I.	NV21581	12549418	SYNCHRO RING, INNER 1-2
154	NV20652	12549413	SYNCHRO RING - REVERSE

KITS

T416R	→	BEARING, GASKET & SEAL KIT, CHEVY
T416RMK	→	BEARING MASTER KIT, CHEVY
T494R	→	BEARING, GASKET & SEAL KIT, DODGE
T494RMK	→	BEARING MASTER KIT, DODGE
RK1500	→	SYNCHRO RING KIT, ALL

NV3500, 5LM60, HM290 STYLE
CHEVY® C/K 1500/2500 - 1988-98 - S10 1990-98
DODGE® DAKOTA, RAM, R1500 1994-98

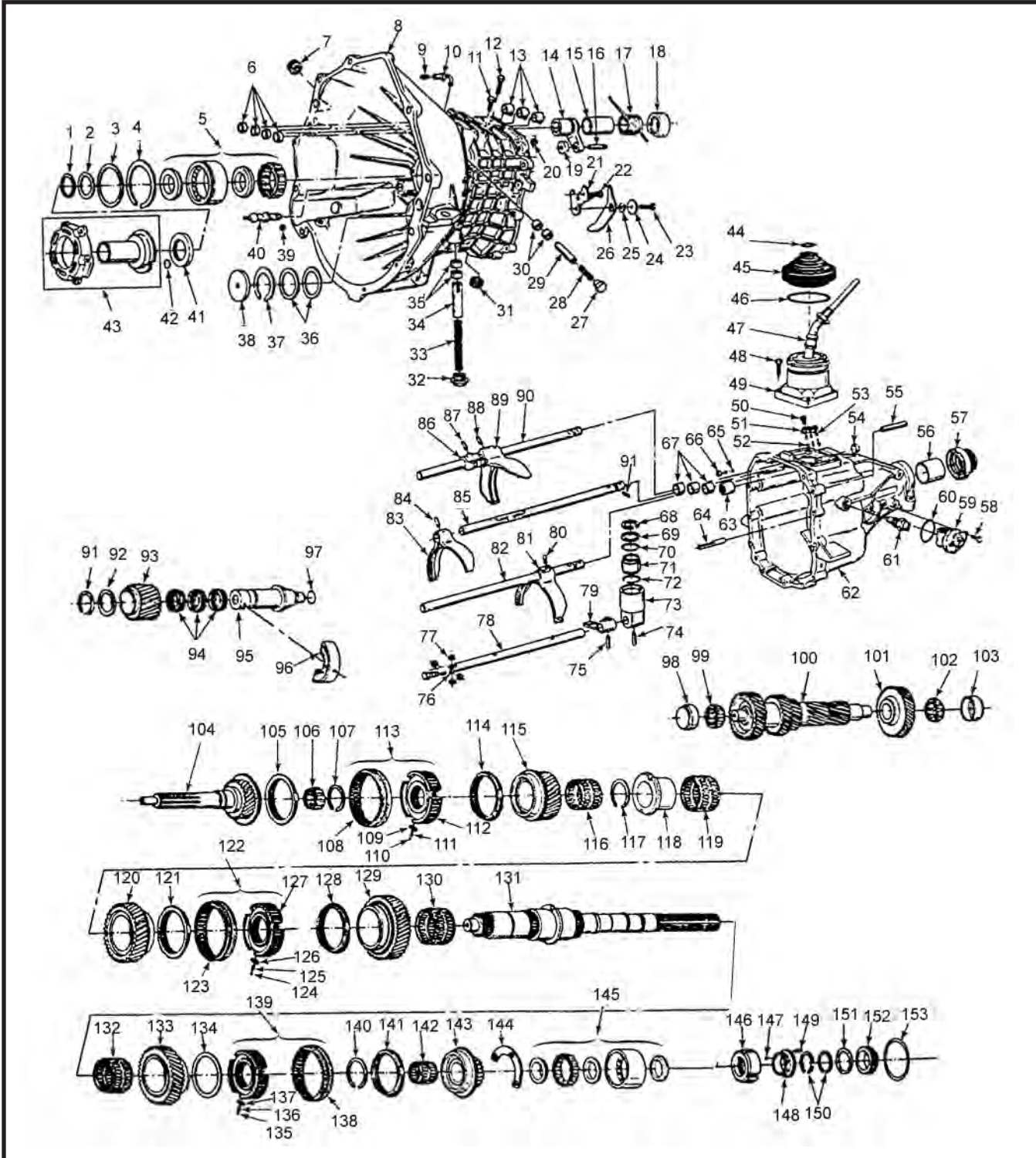

NV3500 STYLE (cont.)

ILL #	MIDWEST #	REF #	REPLACEMENT PART DESCRIPTION
1	8672921		SHIM KIT, INPUT
2	8672645		INPUT BEARING SPACER 1991-92
4	23049936		INPUT BEARING SNAP RING
5	23049494		BEARING, INPUT - EARLY STYLE BALL/ROLLER (THICK 1.3"
		WIDE) - 2 PC.	
5	6307R-8/3BN		BEARING, INPUT - LATE STYLE BAIL ONLY (THIN) - 1 PC.
6	23049549		BUSHING, SHIFT RAIL (3 REQ.)
6	14080573	14080573	SELECTOR RAIL PLUG - FRONT
7	23049841		PLUG - FILL
8	23049610		FRONT CASE - CHEVY FULL SIZE, 1988-90 CASTED (23049844)
8	8672597	12542900	FRONT CASE - CHEVY FULL SIZE, 1991-92
8	NV18355		FRONT CASE - CHEVY FULL SIZE, 1993-95 CASTED (8680834)
8	NV22551		FRONT CASE - CHEVY FULL SIZE, 1996-98 (EXC. BELOW) CASTED (C20841)
8	NV22552	12549374 (C20841)	FRONT CASE - CHEVY FULL SIZE, 1996-98, 5.7L CASTED
8	12473975		FRONT CASE - CHEVY FULL SIZE, 1999-ON, S-10 - 2000-ON
8	8672525		FRONT CASE - CHEVY S-10, 1990
8	8672598		FRONT CASE - CHEVY S-10, 1991-92
8	NV18433	12543765	FRONT CASE - CHEVY S-10, 1993-95 CASTED (8681122)
8	NV18250	4740890	FRONT CASE - DODGE 1994-95 - ALL (C18260)
8	NV24469	4874311	FRONT CASE - DODGE 1996-99 - ALL (C24471)
8	5015187AA		FRONT CASE - DODGE 2000-ON - ALL
9	8672413		BREATHER ASSY - CHEVY FULL SIZE
9	8672242		BREATHER ASSY - S-10, DODGE
11			BOLT
12			BOLT
13	23049549		BUSHING - SHIFT RAIL (3 REQ.)
14	8672244		BIAS LEVER ASSY USED w/o BIAS CAM
15	23049871		SLEEVE - BIAS SPRING
16	8672246		BIAS ROLLER PIN USED w/o BIAS CAM
17	8678655		BIAS SPRING - FULL SIZE - USED w/o BIAS CAM
18	23049866		SEAT - BIAS SPRING SEAT
27	23049887		PLUG, SELECTOR RAIL DETENT
28	NV18120	8672307	SPRING, SELECTOR RAIL DETENT
29	8681415	8681415	PLUNGER, SELECTOR RAIL DETENT
31	NV21041		PLUG, DRAIN
36			SHIM, C/S FRONT
37	8677695		SNAP RING, C/S FRONT
38	8672243		PLUG, C/S FRONT
39	23049545		LUBE FITTING, PIVOT BALL
40	23049797		PIVOT BALL
41	23049814	4741296	SEAL INPUT
43	WT290-6	NV22158	RETAINER, FRONT BEARING, 1988-91 CHEVY
43	WT290-6A	8681609	RETAINER, FRONT BEARING, 1992-95 CHEVY
43	NV24424	4874019	RETAINER, FRONT BEARING, DODGE - ALL
43	NV22142	12549362	RETAINER, FRONT BEARING, 1996-ON CHEVY
44	23049579		CLAMP - LEVER BOOT - UPPER, 1988-92 CHEVY
45	23049489		BOOT - SHIFT LEVER, 1988-92 CHEVY
46	23049580		CLAMP - LEVER BOOT - LOWER, 1988-92 CHEVY
47	NSS		SHIFT LEVER - USE ASSY
48	11513824		BOLT - M6-1-2 X 25 (4 REQ.)
48	NV18383	12542901	FLANGED HEAD BOLT (3 REQ.)
49	8672249		LOWER SHIFT ASSY, S-10, TO 1992
49	8678461		LOWER SHIFT ASSY C/K TO 1992 (NO DETENT)
49	NV18785		LOWER SHIFT ASSY C/K 1994-95 (w/o BIAS SPRING)
49	NV26584		LOWER SHIFT ASSY C/K 1996-ON
49	NV26587		LOWER SHIFT ASSY, S-10 - 1996-ON (w/o BIAS SPRING)
49	NV27874		LOWER SHIFT ASSY (3RD DESIGN) - DETENT
49	NV18877		LOWER SHIFT ASSY - DODGE DAKOTA TO 1994 (EXT. ISOLATOR)
49	NV18878		LOWER SHIFT ASSY - DODGE RAM TO 1994 (EXT. ISOLATOR)
50	11513617		BOLT - SHIFT DETENT COVER (2 REQ.)
51	23049863		COVER - SHIFT DETENT
52	14082035		BALL- SHIFT DETENT (3 REQ.)
53	14082036		SPRING - SHIFT DETENT (3 REQ.)
54	23049820		FREEZE PLUGS FOR RAILS (IN BELL HOUSING) 2 SEQ.
55	11500923		BOLT - M8-1.25 X 50 (11 REQ.)

NV3500 STYLE (cont.)

ILL #	MIDWEST #	REF #	REPLACEMENT PART DESCRIPTION
56	WT290-62	23049620	BUSHING - 2WD - C/K
56	NV18127	8672236	BUSHING - 2WD, S-10
56	2801723		BUSHING - 2WD, DODGE®
57	4532N		SEAL - OUTPUT 4WD - ALL
57	4528N	23049496	SEAL - OUTPUT 2WD, - CHEVY®
57	2465		SEAL - OUTPUT 2WD - DODGE®
58	11503005		SCREW - SPEEDO SENSOR (2WD ONLY)
59	8672237		SPEEDO SENSOR
60			O-RING - SPEEDO SENSOR (2WD ONLY)
61	WT290-71	23049569	SWITCH - REVERSE LIGHTS
62	8672973		REAR CASE, EXTENSION - CHEVY FULL SIZE 2WD, 1988-91
62	8672974		REAR CASE, EXTENSION - CHEVY FULL SIZE 4X4, 1988-91
62	8672602		REAR CASE, EXTENSION - CHEVY FULL SIZE 4WD, 1991-92
62	8672606		REAR CASE, EXTENSION - CHEVY FULL SIZE 2X4, 1991-92
62	8681134		REAR CASE, EXTENSION - CHEVY FULL SIZE 2WD -1993 CAST (8680835)
62	8681136		REAR CASE, EXTENSION - CHEVY FULL SIZE 4X4, 1993 CAST (8680836)
62	NV20823	12547322	REAR CASE, EXTENSION - CHEVY FULL SIZE 2WD - 1994-96 CAST (C20842)
62	NV20825	12547324	REAR CASE, EXTENSION - CHEVY FULL SIZE 4X4 - 1994-96 CASTED (C20843)
62	NV20824	12547323	REAR CASE, EXTENSION - CHEVY FULL SIZE 2WD - 1995 (C20842) (5.7L)
62	NV20837		REAR CASE, EXTENSION - CHEVY FULL SIZE 4X4 - 1996 (C20843) (5.7L)
62	8672232		REAR CASE, EXTENSION - CHEVY S-10, 2WD - 1990
62	8672490		REAR CASE, EXTENSION - CHEVY S-10, 4X4 - 1990 T-TRUCK
62	8672607		REAR CASE, EXTENSION - CHEVY S-10, 2WD - 1991-92
62	8672603		REAR CASE, EXTENSION - CHEVY S-10, 4X4 - 1991-92 T-TRUCK
62	8681137		REAR CASE, EXTENSION - CHEVY S-10, 2WD - 1993 (8681129)
62	8681139		REAR CASE, EXTENSION - CHEVY S-10, 4X4 - 1993, CAST (8681131)
62	NV18567		REAR CASE, EXTENSION - CHEVY S-10, 2WD - 1994-95
62	NV18558		REAR CASE, EXTENSION - CHEVY S-10, 4X4 - 1994-95
62	NV20828	12547326	REAR CASE, EXTENSION - CHEVY S-10, 2WD - 1996-ON CAST (C20844)
62	NV20829	12547327	REAR CASE, EXTENSION - CHEVY S-10, 4X4 - 1996-ON CAST (C20845)
62	NV18258	4740985	REAR CASE, EXTENSION - DODGE RAM, 2WD -TO 1999 CAST (C18264)
62	NV18259		REAR CASE, EXTENSION - DODGE RAM, 4X4 -TO 1999 CAST (C18262)
62	5003287AA		REAR CASE, EXTENSION - DODGE RAM, 2WD -2000
62	5014483AA		REAR CASE, EXTENSION - DODGE RAM, 4X4 - 2000
62	NV18256	4740972	REAR CASE, EXTENSION - DAKOTA, 2WD - TO 1999 (C18263)
62	NV20418	4741272	REAR CASE, EXTENSION - DAKOTA, 4X4 - TO 1999 (C18261)
62	5003286AA		REAR CASE, EXTENSION - DAKOTA, 2WD - 2000
64	23049843		OIL TUBE
65	8681415		SHIFT RAIL DETENT PLUNGER
N.I.	8672307		SHIFT RAIL DETENT SPRING -1991-92
66	23049887		SHIFT RAIL DETENT PLUG
67	F82852	23049817	BEARING, MAIN SHIFT RAIL - REAR
67	14080853	13049549	BUSHING, SHIFT RAIL (3 REQ.)
73	23049485		SELECTOR SOCKET - FULL SIZE CHEVY, 1988-91
73	8672264		SELECTOR SOCKET - S-10, 1988-91
73	8677555		SELECTOR SOCKET - CHEVY - ALL 1992
73	8681147		SELECTOR SOCKET - CHEVY 1993-94 - BIAS SPRING
73	NV23326	12382770	SELECTOR SOCKET - CHEVY 1995-ON w/o BIAS SPRING
73	NV20145	4773949	SELECTOR SOCKET - DODGE® - ALL
74	8672316	4741139	ROLL PIN, SELECTOR SOCKET
75	8672316		ROLL PIN, SELECTOR RAIL
76	14082020		PIN, SELECTOR ROLLER (2 REQ.)
77	23049899		ROLLER, SELECTOR RAIL (4 REQ.)
78	8672310		SELECTOR RAIL - FULL SIZE CHEVY - 1988-92
78	8672277		SELECTOR RAIL - S-10 CHEVY - 1988-92
78	NV22535	4798771	SELECTOR RAIL - CHEVY 1993-ON, DODGE RAM 4X4
78	NV22537	4798770	SELECTOR RAIL - DODGE® - ALL (EXC. ABOVE)
79	8672309		SELECTOR FINGER
80	8672316		ROLL PIN, 5-REV. FORK
81	5672262	WT290-23B	SHIFT FORK, 5-REV. (3 RAIL DESIGN) 1988-92
81	NV20046	NV8681140	SHIFT FORK, 5-REV. FULL SIZE CHEVY/RAM (8" LUG BAR) 1993-ON
81	NV20047	NV8681141	SHIFT FORK, 5-REV., S-10, DAKOTA (5 1/2" LUG BAR) 1993-ON
82	8672263		SHIFT RAIL, 5-REV. (3 RAIL DESIGN) 1988-92
83	WT290-23A	8672260	SHIFT FORK, 3-4 (3 RAIL DESIGN) 1988-92
83	NV25418	NV3500-23A	SHIFT FORK, 3-4 - 1993-ON
84	11513033		ROLL PIN, FORK
85	8672261		SHIFT RAIL, 3-4
86	23049474		SHIFT LUG, 1-2
87	8672316	14092004	ROLL PIN

NV3500 STYLE (cont.)

ILL #	MIDWEST #	REF #	REPLACEMENT PART DESCRIPTION
88	8672316		ROLL PIN
89	8672119		SHIFT FORK, 1-2, 1988-92 CHEVY® - RAIL (3 RAIL DESIGN)
89	NV25420	12382793	SHIFT FORK, 1-2, 1993-ON CHEVY®, DODGE® - ALL
90	NV22535	12549370	SHIFT RAIL, 1-2, (SINGLE RAIL DESIGN) ALL
90	23049640		SHIFT RAIL, 1-2 (3 RAIL DESIGN) - ALL
91	8672316		ROLL PIN, SHIFT RAIL - 1992
91A	23049746		SNAP RING, IDLER GEAR - 1ST AND 2ND DESIGN - 40mm SHAFT DIAMETER
91A	NV18298	12545788	SNAP RING, IDLER GEAR - 3RD DESIGN - 30mm SHAFT DIAMETER
N.I.	NV18296	12545785	SPRING WASHER, IDLER GEAR - 3RD DESIGN - 30mm SHAFT DIAMETER
N.I.	NV18297	12545786	FLAT WASHER, IDLER GEAR - 3RD DESIGN - 30mm SHAFT DIAMETER
N.I.	14080547		BALL, IDLER THRUST WASHER (2 REQ.) 4mm STEEL
92	23049744		THRUST WASHER, USE WITH 1ST DESIGN IDLER (2 REQ.)
92	8672203		THRUST WASHER, USE WITH 2ND DESIGN IDLER - 40mm SHAFT DIAMETER
92	NV18576	12545787	THRUST WASHER, USE WITH 3RD DESIGN IDLER - 30mm SHAFT DIAMETER
93	23049740		REVERSE IDLER GEAR - CHEVY 1988-89 (2.362 WIDE) 1ST DESIGN - 24T
93	8672202		REVERSE IDLER GEAR - CHEVY 1990-93 (2.06 WIDE) 2ND DESIGN - 40mm SHAFT - 24T
93	NV18575	12545784	REVERSE IDLER GEAR - CHEVY® 1994-ON, DODGE® - ALL , (1.38 WIDE) 3RD DESIGN - 30mm SHAFT - 24T
94	23049741		NEEDLE BEARING, IDLER (3 REQ.) 1ST DESIGN
94	8672201		NEEDLE BEARING, IDLER (1 REQ.) 2ND DESIGN
94	FC67757	NV20204	NEEDLE BEARING, IDLER (1 REQ.) 3RD DESIGN
95	23049742		IDLER SHAFT - 1ST DESIGN
95	8672200		IDLER SHAFT - 2ND DESIGN - 40mm SHAFT
95	NV18573		IDLER SHAFT - 3RD DESIGN - 30mm SHAFT
96	23049747		IDLER SUPPORT - CHEVY® 1988-93 - 40mm SHAFT
96	NV18265		IDLER SUPPORT - CHEVY® 1994-ON - 30mm SHAFT, DODGE® - ALL
97	23049743		O-RING, IDLER SHAFT
98/99	FC68009	NV20822	BEARING, C/S FRONT 1996-ON, CHEVY® - 1-5/16" C/S
98/99	FC68336	8677696	BEARING, C/S FRONT 1991-00 CHEVY®, DODGE® - ALL
98/99	23049623		BEARING, C/S FRONT 1988-90 CHEVY®
100	WT290-8E	23049687	CLUSTER GEAR - CHEVY® FULL SIZE, 1988-90, 1" ENDS, 1" GROOVE 34-28-22-14-14-43
100	8672312		CLUSTER GEAR - CHEVY® S-10, 1990 - 34-28-22-14-14-41
100	5LM60-8	8677746	CLUSTER GEAR - CHEVY® FULL SIZE, 1991-93, 1-3/16" ENDS, 1" GROOVE, 34-28-22-14-14-43
100	8677747		CLUSTER GEAR - CHEVY® S-10, 1991-93, 34-28-22-14-14-41
100	5LM60-8A	12545780	CLUSTER GEAR - CHEVY® FULL SIZE & DODGE® 1994-ON & DODGE® 2002-ON w/NV3550, 1-3/16" ENDS, w/o GROOVE, 34-28-22-14
100	NV20911		CLUSTER GEAR - CHEVY® FULL SIZE, 1996 - 5.7L
100	WT290-8ER	12547403	CLUSTER GEAR - CHEVY® FULL SIZE, 1996-ON, 1-3/16" ENDS, 1/4" GROOVE, 34-28-23-15-14-43 - 1-5/16" ENDS
100	WT290-8D	4796807/ NV20985	CLUSTER GEAR - CHEVY S-10, 1994-95, 1-3/16" ENDS, 1/4" GROOVE, 34-28-23-15-14-37 (LONG REVERSE)
100	WT290-8C	12547404	CLUSTER GEAR - CHEVY® S-10, 1996-ON, 1-3/16" ENDS, 1/4" GROOVE, 34-28-23-15-14-37 (SHORT REVERSE)
100	WT290-8F	4874310	CLUSTER GEAR - DODGE® RAM 1997-ON, DAKOTA 4X4 1997-ON, 1-3/16" ENDS, 46-37-22-14-52 (FINE TEETH)
100	NV24467		CLUSTER GEAR - DODGE® DAKOTA, 2WD, 1997-ON
101	23049688		5TH GEAR, C/S - CHEVY® FULL SIZE 1988-90
101	8672312		5TH GEAR, C/S - CHEVY® S-10, 1990
102/103	FC68336	8677696	BEARING, C/S REAR, 1991-00, CHEVY®, DODGE® - ALL
102/103	FC67402	23049623	BEARING, C/S REAR, 1988-90 CHEVY®
102/103	FC68009	NV20822	BEARING, C/S REAR, 1996-ON CHEVY® - 1-5/16" C/S
104	WT290-16E	23049683	INPUT - CHEVY® 1980-90 - STEP (USE 23049494 WIDE BRG)
104	5LM60-16	12540345	INPUT - CHEVY® 1991-95 w/o STEP (USE WITH THIN BEARING)
104	WT290-16C	12547396	INPUT - CHEVY® 1996-ON w/o STEP
104	WT290-16B	4741294	INPUT - DODGE® 1994-ON; ALSO 2001-ON DODGE w/3.9L ENGINE (OE# 5019723AA/NV40119)- NV3550 JEEP®, 26T (2) I.D. GROOVES INPUT - DODGE® 1997-ON, 35T
104	WT290-16F	4883472AA	
105/114	WT290-14	8672050	SYNCHRO RING, 3-4 ALL
106	FC67402	23049686	PILOT BEARING, M/S - INPUT POCKET
107	8677927		SNAP RING, 3-4 SYNCHRO - CALL WITH APP. (DIFFERENT THICKNESSES)
108	WT290-15		SYNCHRO SLEEVE
109	8672123		KEY, 3-4 SYNCHRO (3 REQ.)
110	14082095		BALL, 3-4 SYNCHRO (3 REQ.)
111	14082096		SPRING, 3-4 SYNCHRO (3 REQ.)
112	N/A		SYNCHRO HUB - USE ASSY
113	NV18130	8677859	SYNCHRO ASSY 3-4 - w/o RINGS

NV3500 STYLE (cont.)

ILL #	MIDWEST #	REF #	REPLACEMENT PART DESCRIPTION
115	WT290-11	23049694	3RD GEAR M/S - CHEVY® 1988-90, 30T
115	WT290-11A / 8672632	4741292	3RD GEAR M/S - CHEVY® 1991-96, ALL (EXC. BELOW), DODGE®, 1994-96, 30T
115	NV22352	12549364	3RD GEAR M/S - CHEVY® 1996 - 5.7L, CHEVY® ALL, 1997-ON, 30T
115	NV24485		3RD GEAR M/S - DODGE® 1997-2000
116	8680486	4741874	NEEDLE BEARING, 3RD M/S - 36mm WIDE
117	NV20890	4741288	SNAP RING - 2ND GEAR
118	NV21351	4746070	THRUST WASHER, M/S 2ND (2 REQ.)
119	8680486	4741874	NEEDLE BEARING, 2ND M/S, SINGLE CONE SYNCHRO, 36mm WIDE
119	NV18796	12548468	NEEDLE BEARING, 2ND M/S, DOUBLE CONE SYNCHRO, 27mm WIDE
120	8672629	4741291	2ND GEAR M/S - CHEVY® TO 1994, DODGE DAKOTA TO 1996, RAM TO 2000 - SINGLE CONE - 39T
120	12548443		2ND GEAR M/S - CHEVY® FULL SIZE 1995
120	NV21361	12549352	2ND GEAR M/S - CHEVY® FULL SIZE 1996 - 5.7L - 39T DUAL CONE
120	NV21239 / WT290-21A	12549340	2ND GEAR M/S - CHEVY® FULL SIZE 1996-2000 - 39T DUAL CONE
120	NV21235	12549344	2ND GEAR M/S - CHEVY® S-10 1996-2000 - 38T DUAL CONE
120	NV20982	4796805	2ND GEAR M/S - DODGE® DAKOTA 1995-96, 2WD ONLY - 38T
120	NV33330	4874358AB	2ND GEAR M/S - DODGE® DAKOTA 1997-ON, 4X4 - 39T
121/128	WT290-14	8672050	SYNCHRO RING 1-2 - SINGLE CONE SYNCHRO
121/128	NV18831	12548466	SYNCHRO RING 1-2 - DOUBLE CONE SYNCHRO
N.I.	NV18834	12548367	SYNCHRO RING 1-2 - INTERMEDIATE - DUAL CONE SYNCHRO
N.I.	NV18835	12548368	SYNCHRO RING 1-2 - INNER - DUAL CONE SYNCHRO
122	NV18131	12540389	SYNCHRO ASSY 1-2 w/o RINGS - ALL (USE - SINGLE CONE SYNCHRO)
122	NV18953	12549332	SYNCHRO ASSY 1-2 w/o RINGS - CHEVY® 1995-ON, DUAL CONE SYNCHRO
122	NV20883	12547378	SYNCHRO ASSY 1-2 w/o RINGS - CHEVY® 1996-98 C/K 5.7L, 1997 DAKOTA , DUAL CONE SYNCHRO
123	WT290-15		SYNCHRO SLEEVE 1-2
124	14082095		SYNCHRO BALL, 1-2 (3 REQ.)
125	14082096		SYNCHRO SPRING, 1-2 (3 REQ.)
126	8672123		SYNCHRO KEY, 1-2 (3 REQ.)
127	N/A		SYNCHRO HUB 1-2 - USE ASSY
129	23049701		1ST GEAR M/S CHEVY® 1988-91 - 43T
129	NV18471		1ST GEAR M/S CHEVY® 1992-94, DODGE® RAM - ALL, DAKOTA 1994-96
129	NV21233	12549342	1ST GEAR M/S CHEVY® S-10, 1995-2000, 40T
129	NV21237	12549337	1ST GEAR M/S CHEVY® F/S, 1995, 5.7L, 1999-ON, DAKOTA 4X4, 1997-ON, 43T
129	NV21359	12549350	1ST GEAR M/S CHEVY® F/S, 1995-98
129	NV20980	4796806	1ST GEAR M/S DODGE® DAKOTA, 2WD, 1997-ON
130	F209395	8680487	1ST GEAR M/S NEEDLE BEARING
131	8672971		MAIN SHAFT CHEVY® FULL SIZE, 2WD, 1988-90
131	WT290-2	8672972	MAIN SHAFT CHEVY® FULL SIZE, 4X4, 1988-90
131	WT290-2	8672972	MAIN SHAFT CHEVY® FULL SIZE, 2WD, 1991-93
131	WT290-2A	8672612	MAIN SHAFT CHEVY® FULL SIZE, 4X4, 1991-93
131	NV18581	12545810	MAIN SHAFT CHEVY® FULL SIZE, 4X4, 1994
131	12545773		MAIN SHAFT CHEVY® FULL SIZE, 2WD, 1994
131	NV18800		MAIN SHAFT CHEVY® FULL SIZE, 2WD 1995
131	NV18801	12548229	MAIN SHAFT CHEVY® FULL SIZE - 4X4, 1995
131	WT290-2B	NV20855 /12547352	MAIN SHAFT CHEVY® FULL SIZE - 2WD, 1996-99 (EXC. BELOW)
131	NV20856	12547353	MAIN SHAFT CHEVY® FULL SIZE - 2WD, 1996-99 - 5.7L
131	WT290-2C	NV20857 /12547354	MAIN SHAFT CHEVY® FULL SIZE - 4X4, 1996-99 (EXC. BELOW)
131	NV20858	12547355	MAIN SHAFT CHEVY® FULL SIZE - 4X4, 1996-99 - 5.7L
131	12476306		MAIN SHAFT CHEVY® FULL SIZE - 2WD, 2000
131	12476305		MAIN SHAFT CHEVY® FULL SIZE, 4X4, 2000
131	8672228		MAIN SHAFT CHEVY® S-10, 2WD, 1990
131	8678296		MAIN SHAFT CHEVY® S-10, 4X4, 1990
131	8672613		MAIN SHAFT CHEVY® S-10, 2WD, 1991-93
131	8677614		MAIN SHAFT CHEVY® S-10, 4X4, 1991-92
131	8678297		MAIN SHAFT CHEVY® S-10, 4X4, 1993
131	NV18582	12545801	MAIN SHAFT CHEVY® S-10, 2WD, 1994
131	NV20859	12548224	MAIN SHAFT CHEVY® S-10, 2WD, 1995-2000
131	NV20860	12547357	MAIN SHAFT CHEVY® S-10, 4X4, 1995-2000
131	NV18849	4762051	MAIN SHAFT DODGE® RAM, 2WD, DAKOTA, 1994-96 - 23.63" O.A. 46-42-42-30
131	NV18851	4762053	MAIN SHAFT DODGE®, 4X4, RAM - 17.00" O.A. - 46-42-42-23
131	NV18850	4762052	MAIN SHAFT DODGE®, 4X4, DAKOTA 1994-96 - 15.38" O.A., 46-42-42-23
131	NV24464		MAIN SHAFT DODGE®, 2WD, DAKOTA 1997-2000
131	NV24465		MAIN SHAFT DODGE®, 4X4, DAKOTA 1997-2000
132	23049706		NEEDLE BEARING, M/S REVERSE - CHEVY® 1988-90
132	F209395	8680487	NEEDLE BEARING, M/S REVERSE - CHEVY® 1991-ON, DODGE - ALL

NV3500 STYLE (cont.)

ILL #	MIDWEST #	REF #	REPLACEMENT PART DESCRIPTION
133	23049704		REVERSE GEAR, M/S - CHEVY® 1988-90, 40T
133	WT290-36	8672620	REVERSE GEAR, M/S - CHEVY 1991-92 - 38T
133	NV18472	12543818	REVERSE GEAR, M/S - CHEVY 1993 - 40T w/o LIP SEAL COUNTERBORE
133	NV18590	12545778	REVERSE GEAR, M/S - CHEVY 1994-98 - LIP SEAL BORE - 38T
133	NV18604	4741284	REVERSE GEAR, M/S - CHEVY 1999-2000, DODGE - ALL - 38T
N.I.	NV18773	12547174	LIP SEAL, M/S REV. GEAR
134/141	WT290-14	8672050	SYNCHRO RING, 5-REV.
138	WT290-15		SYNCHRO SLEEVE 5-REV.
139	NV18132	12540387	SYNCHRO ASSY, 5-REV.
139	NV18723	12545777	SYNCHRO ASSY, 5-REV. (USE - LIPPED SEALS)
140	23049724 THRU		SNAP RING, 5-REV. SYNCHRO - CHEVY LARGE (60mm),
		23049728	DODGE® ALL - SELECTIVE 2.20mm THICK TO 2.00mm
140	23049718 THRU		SNAP RING, 5-REV. SYNCHRO - CHEVY SMALL (57mm)
	23049723		SELECTIVE 2.30mm THICK TO 2.00mm
142	23049693		NEEDLE BEARING, M/S 5TH - CHEVY 1989-93 (USE w/o LIP SEALS)
			33mm WIDE
142	NV18588	12545775	NEEDLE BEARING, M/S 5TH - CHEVY 1994-ON, DODGE - ALL (USE LIP SEALS) 28mm WIDE
143	WT290-18	23049690	5TH GEAR M/S - CHEVY FULL SIZE 1988-90, 24T
143	8672208		5TH GEAR M/S - CHEVY S-10, 1990, 26T
143	8672616		5TH GEAR M/S - CHEVY FULL SIZE, 1991-93, 24T
143	8672617		5TH GEAR M/S - CHEVY S-10, 1991-93, 26T
143	WT290-18	NV18584 /12545776	5TH GEAR M/S - CHEVY FULL SIZE, 1994-95, DODGE - ALL, 24T (USE LIP SEALS)
143	WT290-18A	NV20868	5TH GEAR M/S - CHEVY FULL SIZE, 1994-ON, (EXC. BELOW), 24T (USE LIP SEALS)
143	NV20870	12547366	5TH GEAR M/S - CHEVY FULL SIZE, 1996-ON, - 5.7L, 24T, (USE LIP SEALS)
143	WT290-18B	NV18585 /12545802	5TH GEAR M/S - CHEVY S-10, 1994, 26T, (USE LIP SEALS)
143	NV18818	12548225	5TH GEAR M/S - CHEVY S-10, 1995, 22T, (USE LIP SEALS)
143	NV20871	12547367	5TH GEAR M/S - CHEVY S-10, 1996-ON, 22T, (USE LIP SEALS)
N.I.	NV18774	12547144	5TH GEAR M/S - LIP SEAL
144	23049828		BEARING STRAP - CHEVY 1988-90
144	8672265		BEARING STRAP - 2WD, CHEVY 1991-ON, DODGE® - ALL, THREADED HOLES
144	8672266		BEARING STRAP - 4X4, CHEVY 1991-ON, DODGE - ALL, CLEARANCE HOLES
145	23049494		BEARING, M/S REAR - CHEVY 1988-90 (BALL, ROLLER) 2 PC.
145	6307R-8/3BN	NV20867	BEARING, M/S REAR - CHEVY 1991-ON, DODGE - ALL 1 PC.
146	23049751		M/S NUT - INNER
147			BALL, M/S NUT
148	23049752		OUTER BEARING SPACER
149	11512958		ROLL PIN, M/S NUT
150	8672928		SNAP RING KIT, M/S
151	23049716		SPEEDO SPACER - CHEVY 1988-89, 2WD
152	23049717		SPEEDO ROTOR - CHEVY 1988-89, 40T, USE SPACER 2WD
152	8672207		SPEEDO ROTOR - CHEVY 1990-ON, 40T, USE w/o SPACER 2WD
153	NV23824	4864409	M/S SEALING DONUT, 2WD LATE

NV3500 STYLE (cont.)

KITS

T235R	→	BEARING KIT - CHEVY 1988-89 - 2 PC. INPUT AND M/S BEARING
T235RA	→	BEARING KIT - CHEVY 1989-91 - 2 PC. INPUT AND 1 PC. M/S BEARING
T235RB	→	BEARING KIT - CHEVY 1991-ON - 1 PC. INPUT AND M/S BEARING
T235RE	→	BEARING KIT - CHEVY 1996-ON - LARGER C/S BEARINGS, 2000-ON, NV3550, 4.0L, WRANGLER
T235RC	→	BEARING KIT - DODGE 1990-ON, 2002-UP, 6CYL., LIBERTY (W/30MM O.D. C/S BEARING)
T235RMK	→	BEARING MASTER KIT- SEE DESCRIPTIONS ABOVE TO I.D.
T235RAMK	→	BEARING MASTER KIT
T235RBMK	→	BEARING MASTER KIT
T235RCMK	→	BEARING MASTER KIT, NV3550, 2002-UP, 6CYL., LIBERTY (W/300MM O.D. C/S BEARINGS)
T235RDMK	→	BEARING MASTER KIT 95-ON (DODGE) THIN INPUT/OUTPUT BRG (0.9") C/S BRGS I.D. (1.18")
T235REMK	→	BEARING MASTER KIT
T235RFMK	→	BEARING MASTER KIT, NV3550, 2000-UP, WRANGLER
T235RGMK	→	BEARING MASTER KIT 97-ON (DODGE) w/ 3 PC. RINGS ON 1-2 ASSY ALSO SYNCHRONIZED IN REVERSE
SP3500-50	→	SMALL PARTS KIT
RK3500	→	SYNCHRO RING KIT - SINGLE CONE SYNCHRO
RK3500A	→	SYNCHRO RING KIT - DOUBLE CONE SYNCHRO
RK3500D	→	SYNCHRO RING KIT- (DODGE) 1993-96 w/ SYNCHRONIZED REVERSE
RK3500DL	→	SYNCHRO RING KIT- (DODGE) 97- ON w/ 3 PC. RINGS ON 1-2 ASSY ALSO SYNCHRONIZED IN REVERSE

**SEE QUICK REFERENCE SECTION
STARTING ON PG. 54
FOR ASSISTANCE ON IDENTIFYING
INPUTS AND CLUSTER GEARS**

**Motive
Gear®**



OFFROAD DOMINANCE

is achieved with Motive Gear® ring & pinions. The durability, power, and performance of these gears have been trail tested by professional and hard-core offroad enthusiasts.

**Are you ready to
dominate the trail?**

GETRAG STYE

**MIDWEST #
WT290-8E
REPLACES
OE# 23049687**



**88-90 CHEVY, 1" ENDS WITH
1" GROOVE
34-28-22-14-14**

**MIDWEST #
5LM60-8
REPLACES
OE# 8677746**



**91-93 CHEVY & DODGE, 1-3/16" ENDS
WITH 1" GROOVE
34-28-22-14-14**

**MIDWEST #
5LM60-8A
REPLACES OE#
12545780**



**94-ON CHEVY & DODGE, 1-3/16" ENDS -
NO GROOVE
34-28-22-14**

**MIDWEST #
WT290-8C
REPLACES OE#
12547404**



**96-ON CHEVY S10, 1-3/16" ENDS
WITH 1/4" GROOVE
34-28-23-15-14-43**

**MIDWEST #
WT290-8D
REPLACES OE#
12548347**



**94-ON CHEVY & DODGE, 1-3/16" ENDS
WITH 1/4" GROOVE (LONG REV.)
34-28-23-15-14-37**

**MIDWEST #
WT290-8ER
REPLACES OE#
12547403**



**96-ON CHEVY, 1-5/16" ENDS
34-28-23-15-14-43**

GETRAG STYLE (cont.)



**MIDWEST #
WT290-8F
REPLACES OE#
4874310**

**97-ON DODGE®, 1-3/16" ENDS
46-37-22-14-52**



**MIDWEST #
WT290-16E
REPLACES OE#
23049683**

88-90 CHEVY, 26T WITH STEP



**MIDWEST #
5LM60-16
REPLACES OE#
12540345**

**91-95 CHEVY, 26T - NO STEP
1 I.D. GROOVE**



**MIDWEST #
WT290-16B
REPLACES OE#
4741294**

**1994-ON DODGE, 26T
2 I.D. GROOVES**



**MIDWEST #
WT290-16C
REPLACES OE#
12547396**

**96-ON CHEVY, 26T WITH
3 I.D. GROOVES**



**MIDWEST #
WT290-16F
REPLACES
OE#4883472AA**

97-ON DODGE - 35T

NV4500 STYLE
CHEVY® 1991-98 C/K/P SERIES
DODGE® 1992-98, DODGE® / RAM PICK-UPS

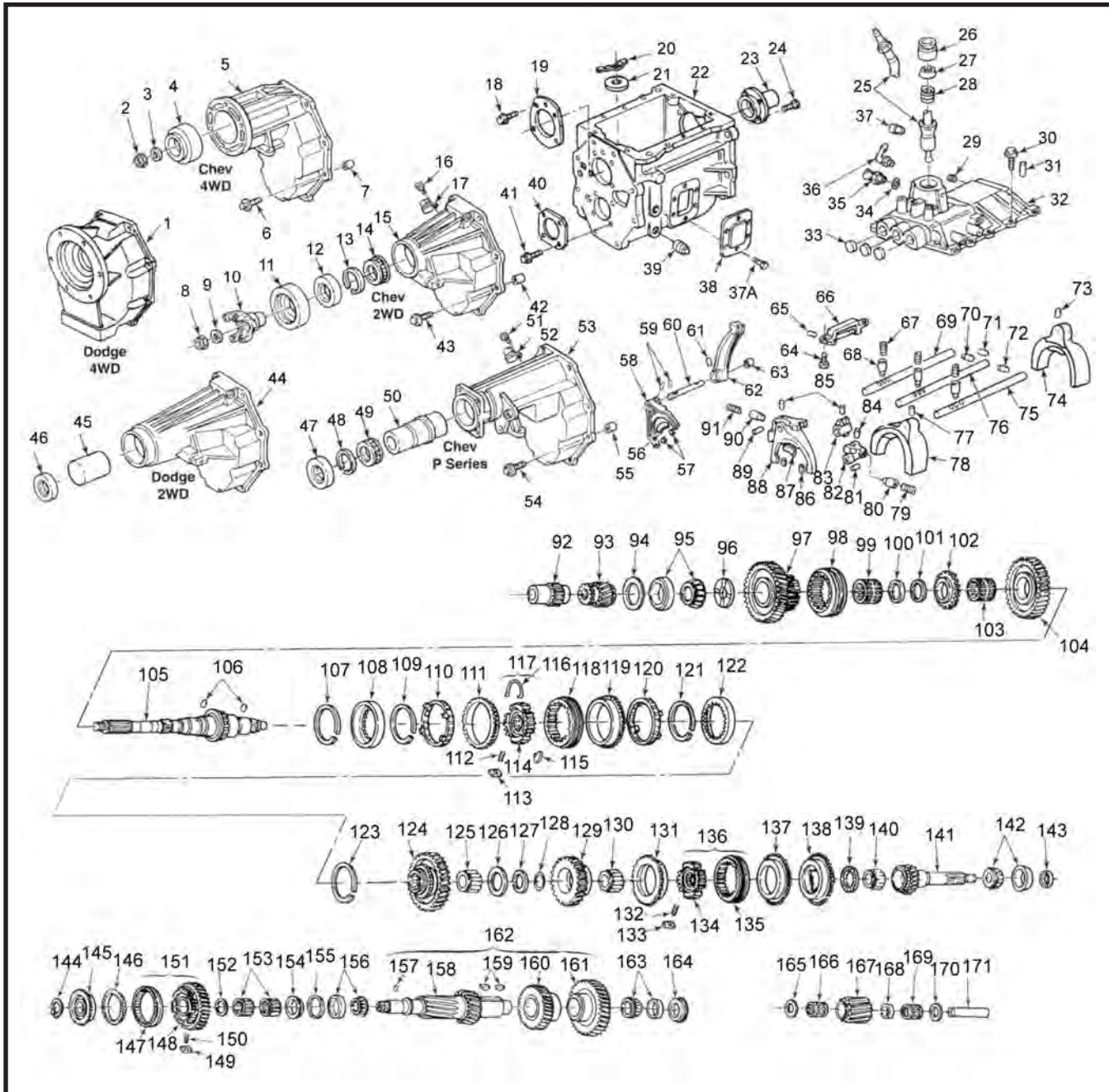

NV4500 STYLE (cont.)

ILL #	MIDWEST #	REF #	REPLACEMENT PART DESCRIPTION
1	NV18106	4723030	EXTENSION, DODGE 4X4 - 1992-93 - CASTED (C18107)
1	NV18169		EXTENSION, DODGE 2WD, DIESEL - CASTED (C 18171)
1	NV17008	4637803	EXTENSION, DODGE 4X4 - 1992-93 - CASTED (C16965)
1	NV26705C	NV18181	EXTENSION, DODGE 4X4 - 1994-2000 - CASTED (C18182) (CAST IRON)
2	NV16899	15635327	NUT M/S, (FOR UNITS W/DAMPER)
2	95203		NUT M/S, GM, 2WD
2/8	NV27133M		NUT KIT - NV4500 - DODGE (UPDATED)
2/8	NV27134		NUT KIT - NV4500 - CHEVY 4x4
3	NV17181	15635326	WASHER M/S - 4WD - DAMPER
4	NV16823	15635329	DAMPER M/S - 4WD CHEVY
4	NV17545	15664907	DAMPER M/S - 4WD CHEVY 6.2L DIESEL
5	NV18305		EXTENSION, CHEVY 4X4 - CASTED (C18306)
6/43/54	NV16862	15635285	BOLT, EXTENSION (8 REQ.)
7/42/55	NV16863	15635284	DOWEL, EXTENSION (2 REQ.)
8	NV16899	15635327	NUT, YOKE
9	NV17181		WASHER, YOKE
9	NV18165		WASHER, YOKE, DODGE, DIESEL
10	NV15999	15635287	YOKE, CHEVY 2WD
10	4741920		YOKE, DODGE 2WD
11	NV17093	15635329	DAMPER, REAR YOKE 2WD
12	NV16781	15635281	REAR SEAL - CHEVY C-SERIES w/o BRAKE
12	NV17137	15635334	REAR SEAL - CHEVY C-SERIES - w/ BRAKE
12/47	NV24982		SEAL, BRAKE DRUM
13/48	NV17165	15635283	SNAP RING - 2WD
14/49	NV18643	12547173	NEEDLE BEARING - 2WD
15	NV16808	15635280	EXTENSION, CHEVY 2WD w/o BRAKE - CASTED (C16808)
15	NV17106	15635333	EXTENSION, CHEVY 2WD - BRAKE TRUCK - CASTED (C17106)
N.I.	NV16965		EXTENSION 4 X 2
16	6501474	15635324	FASTENER, SPEEDO SENSOR
17/52	8672237		SENSOR, SPEEDO - CHEVY - 2WD
18	NV18191	12542559	BOLT, M/S REAR PLATE (4 REQ.)
19	NV16835	15635266	PLATE, M/S REAR BRG.
20	NV11807	2007790	CLIP, MAGNET
21	NV18960	4773012 / 12547191	MAGNET
24	NV16371	15635261	BOLT, FRONT RETAINER (4 REQ.)
22	NV18334	12542903	CASE, MAIN - CHEVY 1992-95 -CASTED (C16812) - REMOTE SLAVE CYLINDER
22	NV22328	12549366	CASE, MAIN - CHEVY 1996-97 -CASTED (C16812) - CONCENTRIC SLAVE CYLINDER
22	NV23165		CASE, MAIN - CHEVY 1997-2000, DODGE 1997-2000 (C23167)
22	NV18156	4741461	CASE, MAIN - CHEVY 1997-2000, DODGE 1997-2000, DODGE 1994-96
22	NV18335	4637683	CASE, MAIN DODGE 1992-93
23	NV17507R	15637295	FRONT RETAINER, CHEVY 1992-95 - CASTED (C17315)
23	NV22414R	12549369	FRONT RETAINER, CHEVY 1996-ON (FLAT STYLE)
23	NV18161R	4741543	FRONT RETAINER, DODGE DIESEL, V10, DIESEL CASTED (C18163)
23	NV18347R	4741542	FRONT RETAINER, DODGE V8, CASTED (C17316)
25	NV17326	15637305	SHIFT LEVER - 1ST DESIGN - GM 1992-93
25	NV17327	4637852	SHIFT LEVER - 1ST DESIGN - DODGE 1992-93
25	NV18465		SHIFT LEVER - 2ND DESIGN - DODGE 1994-95
25	NV18768	4762856	SHIFT LEVER - 2ND DESIGN - DODGE 1994-ON
25	NV20604	12547315	SHIFT LEVER - 2ND DESIGN - CHEVY 1994-96 (EXC. P-SERIES)
25	NV18896		SHIFT LEVER - 2ND DESIGN - CHEVY 1994-96 (P-SERIES)
25	NV25818		SHIFT LEVER - 2ND DESIGN - CHEVY 1997-ON
26	NV17328	15637307	CAP, SPRING (USE w/ SEAT) ROUND TOP
26	NV18453	4741364	CAP, SPRING (USE w/o SEAT) FLAT TOP
27	NV93444	2458324	SEAT - LEVER SPRING - 1ST DESIGN
28	NV17146	4637855 / 15636798	SPRING, SHIFT LEVER (USE w/ SEAT) CYLINDRICAL
28	NV18452		SPRING, SHIFT LEVER (USE w/o SEAT) CONICAL
29	NV9421743	9421743	PLUG - INTERLOCK
30	15635268		BOLT - TOP COVER (10 REQ.)
31	NV16771	4637847 / 15635315	DOWEL PIN (2 REQ.)
32	NV17321	173891 / 15637302	BARE COVER - 1ST DESIGN CHEVY/DODGE #C17321
32	NV18861		BARE COVER - 2ND DESIGN CHEVY (EXC. BELOW) #C18860
32	NV25139	12382804	BARE COVER - 2ND DESIGN CHEVY #C25137
32	NV18607		BARE COVER - 1993-96 DODGE

NV4500 STYLE (cont.)

ILL #	MIDWEST #	REF #	REPLACEMENT PART DESCRIPTION
32	NV25140		BARE COVER - 1996-ON DODGE #C25138
32	NV17389		LOADED COVER - 1ST DESIGN CHEVY/DODGE (CIRCULAR TOP - REVERSE INHIBITOR) #C17321
32	NV26382		LOADED COVER - 2ND DESIGN CHEVY (EXC. BELOW)
32	NV26383		LOADED COVER - 2ND DESIGN CHEVY P-TRUCK, #C25137
32	NV18607		LOADED COVER - 2ND DESIGN DODGE w/o REVERSE INHIBITOR (1993-96)
32	NV25120		LOADED COVER - 2ND DESIGN DODGE (C25138)
32	NV26381		LOADED COVER - 2ND DESIGN DODGE 1997-ON PICK-UP
33	NV17480	4720594 / 15635312	PLUG - SHIFT RAIL (3 REQ.)
34	NV89279	1302807 / 3929530	GASKET - REVERSE LIGHT SWITCH
35	NV14014559	14014559	SWITCH - REVERSE LIGHT
36	NV17465	4741660 / 12542560	BREATHER ASSY, (CHEVY P-SERIES/DODGE)
36	NV17988		BREATHER ASSY, (EXCEPT P-SERIES)
37	NV17376		PIN, TRUNNION - 1ST DESIGN (2 REQ.)
37	NV18737	4762400	PIN, TRUNNION - 2ND DESIGN (2 REQ.)
37A	15595893	9440034	BOLT, PTO COVER (12 REQ.)
38	NV35662	6273213	COVER, PTO (2 REQ.)
39	NV17325	15637304	FILL PLUG
40	NV16954	15635267	PLATE, C/S REAR BRG.
41	NV18191	12542559	BOLT, C/S REAR PLATE (4 REQ.)
44	NV18169	4741559	EXTENSION, DODGE 2WD DIESEL, V10 - CASTED (C18171)
44	NV18293	4741558	EXTENSION, DODGE 2WD GAS - CASTED (C18186)
45	NV18172		EXTENSION HOUSING BUSHING
45	NV23339		EXTENSION HOUSING BUSHING - P SERIES w/ BRAKE
45	NV25086		EXTENSION HOUSING BUSHING - P SERIES w/o BRAKE
46	NV18173	4741920	REAR SEAL - DODGE 2WD DIESEL - V10 - 1994-96 - CAN USE 4741
46	NV3515383	4741119	REAR SEAL - DODGE 2WD - V8
47	NV17062	15636443	REAR SEAL - CHEVY P-SERIES w/o BRAKE
47	NV17063	15635391	REAR SEAL - CHEVY P-SERIES - BRAKE
47	NV19601		REAR SEAL 4X4
50	NV17138	15635332	SPACER - M/S CHEVY 2WD - CALL FOR MORE APPLICATIONS
53	NV23338	12382787	EXTENSION, CHEVY 2WD - BRAKE P-SERIES CASTED (C23337)
53	NV25085	12382810	EXTENSION, CHEVY 2WD P-SERIES w/o PARKING BRAKE CASTED (C23337)
58	NV18937	4773178 / 12547836	FORK 5TH
59	455289		RETAINING PIN
60	NV20231	4778216 / 12548394	SHIFT RAIL, 5TH
61	NV18437	4741362 / 12542972	ROLL PIN
61/73	NV18437	4741362 / 12542972	ROLL PIN (5 REQ.)
62/88	NV18931		FORK REV. DODGE/CHEVY 1ST DESIGN - BIAS PLUNGER
62/88	NV25661		FORK REV. w/o PLUNGER - 2ND DESIGN
63	15635196		BUSHING, 5TH SHIFT RAIL
64	NV16975	4637844 / 15635311	BOLT, REVERSE INHIBITOR
65	9431367		RETAINING PIN
66	NV17119	4637897 / 15635305	REVERSE INHIBITOR ASSY
N.I.	NV16822	4637692 / 15635200	SHIFT LUG, O.D. - CASTED (C16822)
67	NV16768	4637846 / 15635313	DETENT SPRING - 1ST DESIGN - NATURAL COLOR
67	NV20031		DETENT SPRING - 2ND DESIGN - GREEN - ALL EXC. BELOW
67	NV18876		DETENT SPRING - 2ND DESIGN - ORANGE - P-TRUCK
68	NV16841	4637845 / 15635314	DETENT PLUNGER (3 REQ.)
69	NV16816	4637839 / 15635303	SHIFT RAIL REV.
70/71/72	NV35660	2463338 / 2556882	INTERLOCK PLUNGER (2 REQ.)
74	NV18302	4637829 / 12542894	FORK 3-4
75	NV18320	4637831 / 12542864	SHIFT RAIL 3-4
76	NV17288	4637816 / 15637913	SHIFT RAIL 1-2
77/85	NV18437	4741362 / 12542972	ROLL - PIN (5 REQ.)
78	NV18303	4637815 / 12542893	FORK 1/2
79	NV16868	4637813 / 15635295	BIAS SPRING
80	NV16872	46378121 / 15635294	BIAS PLUNGER
81	455289		RETAINING PIN - BIAS SPRING
81/84	NV88397	1265694 / 2462229	INTERLOCK PIN
82	NV18862		SHIFT LUG 1/2 - 1994-ON CHEVY
82	NV18188	4637811	SHIFT LUG 1/2 - DODGE
83	NV16769		SHIFT LUG 3/4 - 1992-93

NV4500 STYLE (cont.)

ILL #	MIDWEST #	REF #	REPLACEMENT PART DESCRIPTION
83	NV18863		SHIFT LUG 3/4 - 1993-96
83	NV16822		SHIFT LUG 3/4 - 1997-ON
86	NV17201	4637838 / 15635276	FORK PADS - REV. (2 REQ.) STRAIGHT
87	NV17202	4637837 / 15635277	FORK PAD, REV. - CENTER (1 REQ.) CURVED
88	SEE #62		
90	NV16872	4637812 / 15635294	DETENT PLUNGER
91	NV16868	4637813 / 15635295	BIAS SPRING
92	NV16798	15635279	SPEEDO ROTOR GM 1991-95, 1.448" I.D. 2WD
92	NV18777	12546679	SPEEDO ROTOR GM 1994-PRESENT, 1.506" I.D. 2WD
92	NV18881	4762963	SPEEDO ROTOR DODGE - V10 DIESEL - GREEN NYLON 13T
N.I.	NV16811A THRU NV16811S		SHIM, M/S REAR BEARING
93	NV16799R	15635278	5TH GEAR M/S, 19T, 31 SPL. - 6.34 RATIO - CHEVY
93	NV16999R	12548339	5TH GEAR M/S, 22T, 31 SPL. - 5.61 RATIO - CHEVY/DODGE
93	NV18164R	4741551	5TH GEAR M/S, 22T, 35 SPL. - 5.61 RATIO - DODGE V10 /DIESEL
95	M804010		RACE, M/S REAR
95	M804049		BEARING, M/S REAR
96	NV16797	15635252 / 14637763	THRUST WASHER, M/S REVERSE
N.I.	NV17299	4637738	KEYS - REVERSE SYNCHRO (3 REQ.)
97	NV17308R	15637292	REV. GEAR M/S - 39T - CHEVY 1992-96
97	NV23267		REV. GEAR M/S - 35T - CHEVY 1997-ON
97	NV17309	4637760	REV. GEAR M/S - 39T - DODGE 1992-96 - CAN USE NV17583
97	NV23271		REV. GEAR M/S - 35T - DODGE 1997-ON
98	NV17306	4637861 / 15637291	SYNCHRO SLEEVE, M/S REVERSE
N.I.	.NV17346	4637740	SPRINGS - REVERSE SYNCHRO (3 REQ.)
99	F86651	NV16803	NEEDLE BEARING, M/S REVERSE
100	NV23195	12382815	SPACER, M/S REVERSE
101	NV15207	4219085 / 14037974	SNAP RING
102	NV18920	/ 12547203	CLUTCH GEAR, M/S REVERSE - GM 1992-98 w/o CONE
102	NV18923	4723009/	CLUTCH GEAR, M/S REVERSE - DODGE/GM 1999-ON
103	NV21503	4798769 / 15635229	NEEDLE BEARING, M/S 1ST
104	NV17290R	15637279	1ST GEAR M/S L39 - S36 - 52T
105	NV27170R	12382816	MAIN SHAFT, CHEVY 4WD 19-3/4"
105	NV25330R	12382817	MAIN SHAFT, CHEVY 2WD 20-1/4" w/o BRAKE
105	NV25332R	12382819	MAIN SHAFT, CHEVY 2WD - BRAKE
105	NV25331R	12382818	MAIN SHAFT, CHEVY P-SERIES w/o BRAKE
105	NV17281	4637711	MAIN SHAFT, DODGE 4X4 - 1992-93 V8, 32 SPL.. 19-1/4" O.A.
105	NV17280	4637714	MAIN SHAFT, DODGE 2WD 1992-93
105	NV27173	NV25328	MAIN SHAFT, DODGE 4X4 DIESEL, V10 - CAN USE 4882318K (SEE KITS)
105	NV27171R	NV25326	MAIN SHAFT, DODGE 4X4 GAS, 23 SPL. 17-1/2" O.A.
105	NV27176	NV25325	MAIN SHAFT, DODGE 2WD DIESEL, V10 - CAN USE 4741468K (SEE KITS)
105	NV27172		MAIN SHAFT, DODGE 2WD GAS - 24.25"
106	NV99086	2952592 / 9431704	PIN, THRUST WASHER
107/109/121	NV16875	4637716 / 15635217	SNAP RING - M/2 1/2 SYNCHRONIZER (4 REQ.)
108/122	NV17084	4637717 / 15635216	SYNCHRO RING, INNER CONE 1/2 (2 REQ.)
110/120	NV17078	4637718 / 15635219	SYNCHRO RING, CENTER FRICTION 1/2 (2 REQ.) (4 TABS)
111/119	NV17284	4637719 / 15637274	SYNCHRO RING, OUTER RING 1/2 (2 REQ.)
114	NV17282	4637709 / 15637273	HUB 1/2 SYNCHRO
112	14082096	4741137	SYNCHRO SPRING (4 REQ.)
113	NV17289	4637721 / 15637275	SYNCHRO KEYS (4 REQ.)
115	NV17144	4637723 / 15635224	BLOCK - INHIBITOR (4 REQ.)
116	NV17286	4637724 / 15637277	INHIBITOR SPRING, 1ST GEAR DOWNSHIFT
116	NV17287	4637725 / 15637278	2ND GEAR DOWNSHIFT
116	NV23677	/ 12382775	2ND GEAR DOWNSHIFT
117	NV23678	12382776	SYNCHRO ASSY 1/2
118	NV17283		SYNCHRO SLEEVE 1/2
123	NV16875		SNAP RING
124	NV17293R	15637281	2ND GEAR, M/S 37T
125	NV21503	4798769 / 15635229	NEEDLE BEARING, M/S 2ND
126	NV16795	4637732 / 15635232	THRUST WASHER, M/S 3RD
127	NV16794	4637733 / 15635233	SNAP RING, M/S 3RD
128	NV23193	12382814	SPACER, 3RD GEAR - BEARING (SINGLE ROW)
129	NV18922	12542867	3RD GEAR M/S 28T, 6.34 RATIO
129	NV23712R	12382792	3RD GEAR M/S 29T, 5.61 RATIO
130	NV21504	4798768	NEEDLE BEARING, 3RD GEAR M/S (SINGLE ROW)
130	NV17194	4637736 /	NEEDLE BEARING, 3RD GEAR M/S (2 REQ.) DOUBLE ROW
131/137	NV17298	4637739 / 15637286	SYNCHRO RING 3/4 (2 REQ.)
134	NV17301		SYNCHRO HUB (USE ASSY) 3/4

NV4500 STYLE (cont.)

ILL #	MIDWEST #	REF #	REPLACEMENT PART DESCRIPTION
132	NV17346	4637740 / 15637912	SYNCHRO SPRING 3/4 (3 REQ.)
133	NV17299	4637738 / 15637285	SYNCHRO KEY 3/4 (3 REQ.)
135	NV18321		SYNCHRO SLEEVE - 3/4
136	NV18412R		SYNCHRO ASSY 3/4 - ALL - HUB & SLIDER
138	NV21313R	4874370	CLUTCH RING, INPUT
139	NV16807	4637755 / 15635245	THRUST BEARING, MAIN SHAFT
140	NV16805	4637774 / 15638007	PILOT BEARING, M/S
141	NV17310R	15637293	INPUT SHAFT 20T - CHEVY, 6.34 RATIO
141	NV20018R	12548483	INPUT SHAFT 22T - CHEVY, 5.61 RATIO
141	NV17311R	4637772	INPUT SHAFT 22T - DODGE®, GAS, 19 SPL.
141	NV25354R	4882357	INPUT SHAFT - DODGE GAS, V8 - 22T
141	NV25356R	4882358	INPUT SHAFT - DODGE DIESEL, V10 - 22T
142	NP728109	NV21298	RACE, INPUT - LATE 1997-ON CHEVY ONLY
142	M802011	4741544 /	RACE, INPUT EARLY - 1996-DOWN CHEVY ONLY
142	M802048	4723145 /	BEARING, INPUT - EARLY & LATE CHEVY & DODGE
143	NV21901	05012115AA	SEAL, INPUT - LATE - 1997-ON
143	NV16780	15635260	SEAL, INPUT - EARLY - 1996-DOWN
144	NV22418	4864472 / 12382766	SNAP RING C/S 5TH CLUTCH RING
145	NV18921	4637792 / 12547204	CLUTCH RING, C/S 5TH - CONE
146	NV17307	4637792 / 15637298	SYNCHRO RING, C/S 5TH
147	NV17306	4637861 / 15637291	SYNCHRO SLEEVE, C/S 5TH
148	NV17317R	15637296	5TH GEAR C/S, 51T ENGAGES - 19T, M/S GEAR 6:34 RATIO
148	NV17318R	12548338	5TH GEAR C/S, 51T ENGAGES - 22T, M/S GEAR 5:61 RATIO
149	NV17299	4637738 / 15637285	SYNCHRO KEY, C/S 5TH (3 REQ.)
150	NV17346	4637746 / 15637912	SYNCHRO SPRING, C/S 5TH (3 REQ.)
151	NV17581	12540300	SYNCHRO ASSY - C/S 5TH - 51T - 6.34 RATIO - 1993-DOWN
151	NV17582	12548337	SYNCHRO ASSY - C/S 5TH - 51T - 5.61 RATIO - 1994-ON
152	NV17200	4637788 / 15635271	SPACER, C/S BEARING (USE - SINGLE ROW ONLY)
153	K40X48X20	NV17195	NEEDLE BEARING, C/S 5TH (SINGLE ROW, 2 REQ.)
153	NV21505	4882541 / 12382813	NEEDLE BEARING, C/S 5TH (DOUBLE ROW, 1 REQ.)
154	NV16874	4637778 / 15635262	THRUST WASHER, C/S 5TH
N.I.	NV16853	4637780 / 15635263	SHIM KIT, C/S
156	LM501310	4637707 / 15637271	RACE, C/S REAR
156	LM501349	4637708 / 15637270	BEARING, C/S REAR
157	NV99086	4773176 / 9431704	PIN, C/S THRUST WASHER
159	NV17499	4637702 / 12542558	KEYS, C/S (2 REQ.)
160	NV17329	15637267	3RD GEAR C/S - 32T - 6.34 RATIO
160	NV17330R	4637703	3RD GEAR C/S - 30T - 5.61 RATIO
161	NV17271R	15637268	DRIVE GEAR, COUNTERSHAFT 39T, 6.34 RATIO
161	NV17272R		DRIVE GEAR, COUNTERSHAFT 38T, 5.61 RATIO
162	NV22608R	12382796	COUNTERSHAFT ASSY - 1 PIECE 1990-96, 5.61 RATIO, 38-30-21-12
162	NV22657R		COUNTERSHAFT ASSY - 1 PIECE 1997-ON, 5.61 RATIO
162	NV17500	12542902	COUNTERSHAFT, CHEVY 6.34 RATIO
163	LM102910	4637691 / 15637265	RACE, C/S FRONT
163	LM102949	4637705 / 15637269	BEARING, C/S FRONT
164	NV16846	4637689 / 15635197	CAP, C/S FRONT BEARING
165/170	NV23211	12382812	THRUST WASHER, REVERSE IDLER (2 REQ.)
166/169	NV16772	4637695 / 15635202	NEEDLE BEARING, REVERSE IDLER (2 REQ.) 1996-DOWN -WIDE GEAR
166/169	NV23265	12382832	NEEDLE BEARING, REVERSE IDLER (2 REQ.) 1977-ON
167	NV16785R	15635201	REVERSE IDLER GEAR 1991-96 (3")
167	NV23266		REVERSE IDLER GEAR 1997-ON (1-1/2")
168	NV16818	46376961 / 15635203	SPACER, REVERSE IDLER BEARING
171	NV18845	4762401 / 12548476	SHAFT, REVERSE IDLER
N.I.	NV18873		SHIFT LEVER ISOLATOR (SPACER) - USES w/ 4 BOLT SQUARE COVER (RUBBER ON SIDE ONE / METAL ON SIDE TWO)

NV4500 STYLE (cont.)

KITS

T308R	→	NV4500 DODGE & CHEVY - NEEDLE
T308RA	→	NV4500 DODGE & CHEVY - w/o NEEDLES
T308RL	→	NV4500 CHEVY LATE - 1996-LATER - NEEDLE
T308RLA	→	NV4500 CHEVY LATE - 1996-LATER - w/o NEEDLE
T308RMK	→	NV4500 DODGE & CHEVY - NEEDLE MASTER KIT
T308RAMK	→	NV4500 DODGE & CHEVY - w/o NEEDLE MASTER KIT
T308RLMK	→	NV4500 CHEVY - 1996-LATER - NEEDLE MASTER KIT
T308RLAMK	→	NV4500 CHEVY - 1996-LATER - w/o NEEDLE MASTER KIT
SP4500-50	→	SMALL PARTS KIT
SP4500-50A	→	THRUST WASHER AND SNAP RING KIT
SP4500-50D	→	SMALL PARTS KIT - COMPLETE DODGE
SP4500-50GM	→	SMALL PARTS KIT - COMPLETE GM
NV16811K	→	SHIM KIT M/S
NV16853	→	SHIM KIT C/S
NV4500-K3	→	3-4-5-REV. SYNCHRO KEY & SPRING KIT - 1 PER ASSY
RK4500	→	SYNCHRO RING KIT
RK4500D	→	DODGE SYNCHRO RING KIT
4882318K	→	DODGE M/S - 4X4 (INCLUDES SNAP RINGS AND HALF MOONS)
4741468K	→	DODGE M/S - 2WD (INCLUDES SNAP RINGS AND HALF MOONS)
5013887AA	→	DODGE DIESEL UPDATED M/S NUT
NK308	→	NEEDLE BEARING KIT, ALL

SM465 STYLE CHEVROLET® 1968-91

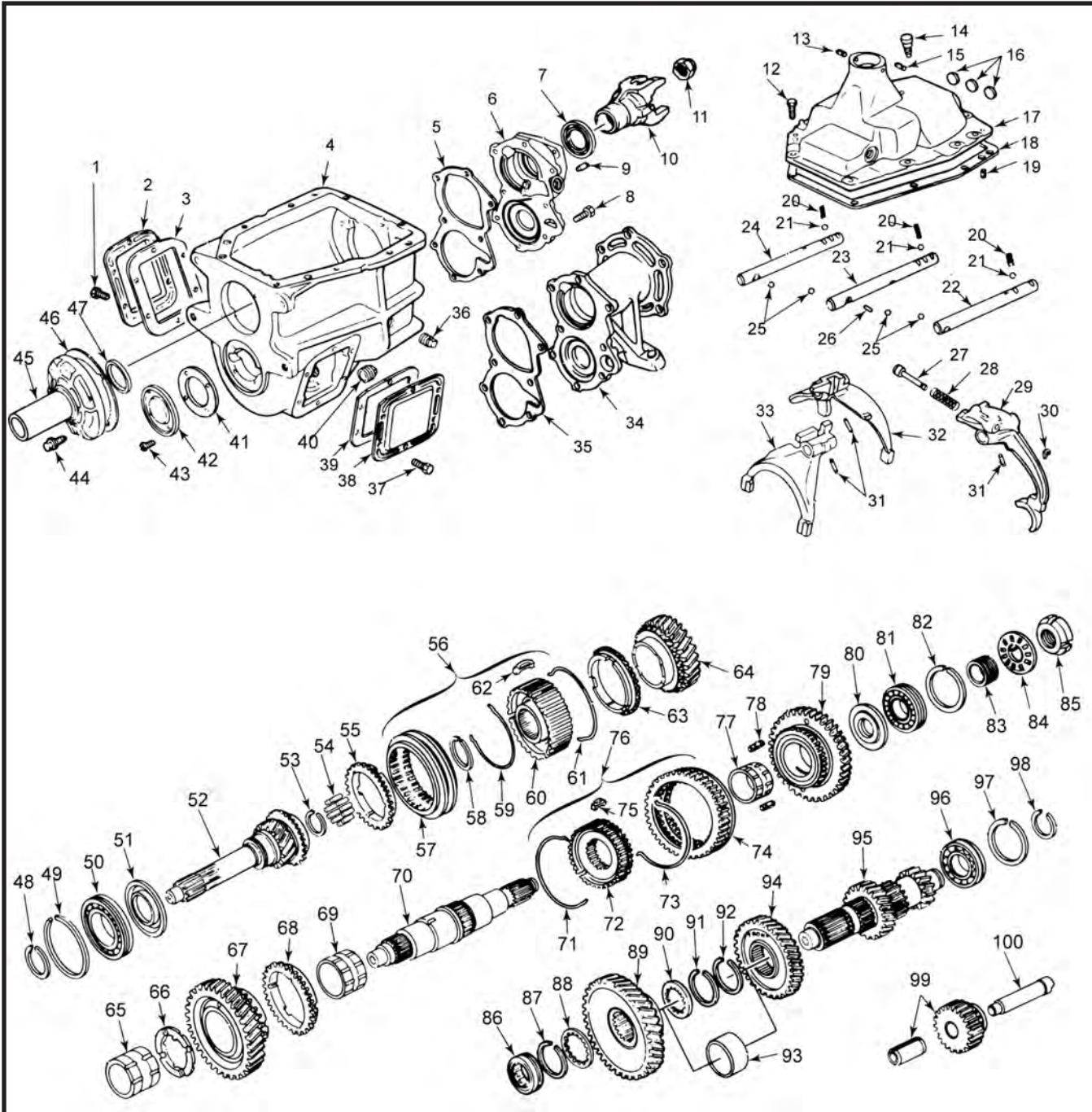

SM465 STYLE (cont.)

ILL #	MIDWEST #	REF #	REPLACEMENT PART DESCRIPTION
1/37	N.A.		BOLT, PTO COVER
2/38	NV35662	6273213	COVER, PTO
3/39/46/ 5/35/41	G5304-55		GASKET SET
4	WT304-1	3901126	CASE ASSY
4	WT304-1A	465453	CASE ASSY - 1987-ON
6	WT304-7A	465214	RETAINER, REAR BEARING w/o SHAFT BRAKE
6	WT304-7C	465217	RETAINER, REAR BEARING - SHAFT BRAKE
7	410085N		SEAL, M/S - ALL
8	2059927		BOLT, REAR RETAINER
9	N.A.		DOWEL PIN 5/16" X 3/4"
10	3915056		YOKE, 2WD
10	3866674		YOKE, 4WD
11	95203		NUT, M/S REAR
12	2059927		BOLT - TOP COVER
13	623-024		SHIFTER PINS
14	N.A.		ALIGNMENT BOLT
16	N.A.		WELCH PLUG
17	8672011		TOP COVER - ALUM.
17	WT304-26	3952668	TOP COVER - IRON
19	N.A.		DOWEL PIN 3/8" X 7/8"
20	N.A.		SPRING, DETENT
21/25	551946		BALL, DETENT
22	WT304-20B	3901132	RAIL, REV. FORK - IRON COVER
22	8672014		RAIL, REV. FORK - ALUM. COVER
23	WT304-20A	3952769	RAIL, 3-4 FORK - IRON COVER
23	8672013		RAIL, 3-4 FORK - ALUM. COVER
24	WT304-20		RAIL, 1-2 FORK - IRON COVER
24	8672012		RAIL, 1-2 FORK - ALUM. COVER
26	3901139		PIN, INTERLOCK
27	WT304-24	3864968	PLUNGER, REVERSE FORK
28	3978731		SPRING, REVERSE PLUNGER
29	WT304-22B	3978730	FORK REV. IRON COVER
29	WT304-22J		FORK REV. ALUM. COVER - LATE STYLE
30	3727182		CLIP, REVERSE FORK
31	N.A.		ROLL PIN
32	WT304-22	3901137	FORK, 1-2 - IRON COVER
32	WT304-22G		FORK, 1-2 - ALUM. COVER - LATE STYLE
33	WT304-22A	3901138	FORK, 3-4 IRON COVER
33	WT304-22H		FORK, 3-4 ALUM. COVER - LATE STYLE
34	WT304-7		RETAINER/ADAPTER - ALL 4X4
36	N.A.		1/2" PIPE PLUG, FILL
40	N.A.		1/2" PIPE PLUG, DRAIN
42	WT304-7	3866347	BEARING CAP - FRONT C/S
43	N.A.		SCREW, FRONT C/S RETAINER
44	3920784		SCREW - FRONT RETAINER
45	WT304-6	39001178	BEARING RETAINER, FRONT - 1-1/6" 10 SPL. INPUT - L.D.
45	WT304-6A	3905403	BEARING RETAINER, FRONT - 1-1/2" 10 SPL. INPUT - H.D.
47	481181N		SEAL, FRONT - ALL
48	3901152		SNAP RING, FRONT BEARING RETAINING
49	3866655		SNAP RING, FRONT BEARING
50	N1211L		BEARING, INPUT EARLY - TO 1990 (NARROW)
50	211FFLE		BEARING, INPUT LATE - TO 1990-ON (WIDE)
51	3901177		SLINGER, FRONT BEARING
52	WT304-16	3901176	INPUT - 10-11/16" - 1-1/2" 10 SPL. H.D.
52	WT304-16A	3901175	INPUT, 9-5/8" - 1-1/16" 10 SPL. L.D.
52	WT304-16C	8672408	INPUT, 9-5/8" - 1-1/16" 10 SPL. L.D. - TMZ11 BEARING - 1988-ON
53	3901166		RETAINING RING, M/S PILOT
54	QAR34604	9422666	BEARING, M/S PILOT (17 REQ.)
55	WT304-14A	3993036	SYNCHRO RING 3-4
56	AWT304-2.5		3-4 SYNCHRO ASSY w/ RINGS
57	WT304-15	3901165	SLEEVE, 3-4 SYNCHRO - CAN USE WT304-11AX
58	3901166		SNAP RING, SYNCHRO RETAINING
59/61	WT304-78	3866359	SPRING, 3-4 SYNCHRO
60	WT304-2.5	3901164	HUB, 3-4 SYNCHRO
62	WT304-77	3932274	KEY, 3-4 SYNCHRO
64	WT304-11	3901161	3RD GEAR, M/S 26T - ALL

SM465 STYLE (cont.)

ILL #	MIDWEST #	REF #	REPLACEMENT PART DESCRIPTION
64	WT304-11AX		3RD GEAR, M/S 26T - UPDATE KIT INCLUDES SLIDER
65	WT304-19A	3932274	BUSHING, 3RD GEAR
66	3932267		THRUST WASHER, 3RD GEAR
67	WT304-21	3901158	2ND GEAR, M/S 35T
68	WT304-83A	3950367	SYNCHRO RING, 2ND GEAR
69	WT304-19	3932253	BUSHING, 2ND GEAR
70	WT304-2A	3932265	MAIN SHAFT - 2WD - 15-11/16" O.A. 33-46 - 36 SPL.
70	WT304-2D	14020859	MAIN SHAFT - 4WD - 19-3/4" O.A. 33-46 - 32 SPL.
70	AWT304-2C	6259663	MAIN SHAFT - 4WD - 13-3/8" O.A. 33-46 -10 SPL.
71	WT304-79	3866646	SPRING, 1-2 SYNCHRO
72	WT304-81	3946776	HUB, 1-2 SYNCHRO
74	WT304-36	3901170	SLIDER, 1-2 SYNCHRO / M/S REVERSE 44T
75	WT304-77	3866358	KEY, 1-2 SYNCHRO
76	AWT304-80		SYNCHRO ASSY 1-2 w/ RINGS
77	WT304-19B	465455	BUSHING, 1ST GEAR
78	WT304-77	3866358	KEY, 1ST GEAR
79	AWT304-12	3932256	1ST GEAR, M/S 39T - ALL
80	465450		THRUST WASHER, 1ST GEAR
81	1308L		BEARING, M/S REAR
82			SNAP RING
83	VARIOUS APPLICATIONS		SPEEDOMETER GEAR (CONTACT MANUFACTURER)
84	335366		LOCK WASHER, M/S REAR
85	WT304-90		LOCK NUT, M/S - 2WD - CAN USE 1227C939
85	12388448		LOCK NUT, M/S - 4X4
86	FC66263.2	5707	BEARING, C/S FRONT
87	3920703		SNAP RING, C/S BEARING
88	3901153		THRUST WASHER, C/S FRONT
89	AWT304-9A	3955570	DRIVE GEAR, COUNTERSHAFT 40T - ALL
90			WASHER
91	3920705		SNAP RING, C/S
92			SNAP RING
93	WT304-17	14020811	SPACER, C/S (REPLACES 123-125)
94	WT304-34	3968038	3RD GEAR, C/S 36T
95	WT304-3	3901146	COUNTERSHAFT - EARLY - 1.34 FRONT C/S BEARING SURFACE
95	WT304-3A	14053671	COUNTERSHAFT- LATE - 1.40 FRONT C/S BEARING SURFACE
96	1308L		BEARING, C/S REAR
97			SNAP RING
98	3866346		SNAP RING, C/S BEARING RETAINING
99	WT304-10	3901141	REVERSE IDLER GEAR, 23T - ALL
100	WT304-35	3901144	SHAFT, REV. IDLER
N.I.	6259656R		COUPLER 10 SPL. 205 T/C
N.I.	6273964R		COUPLER 27 SPL. 205 T/C
N.I.	8640496		VENT

SM465 STYLE (cont.)

KITS

T157R	→ BEARING KIT - 1968-78
T157RL	→ BEARING KIT - 1979-ON
T157RMK	→ BEARING KIT - SMALL PARTS - SYNCHRO KEYS & SPRINGS, SYNCHRO RINGS 1968-7
T157RLMK	→ BEARING KIT - SMALL PARTS - SYNCHRO KEYS & SPRINGS, SYNCHRO RINGS 1979-ON
K157	→ GASKET & SEAL KIT
SP304-50	→ SMALL PARTS KIT
GS304-55	→ GASKET SET
WT304K1	→ KEY & SPRING KIT - 1-2 SYNCHRO
WT304K3	→ KEY & SPRING KIT - 3-4 SYNCHRO
WT304-11AX	→ 3RD GEAR KIT - UPDATE - TORQUE-LOCK SYNCHRO TEETH - ANTI-JUMP-OUT
WT304-28	→ SHIFT STICK - IRON COVER
WT304-28A	→ SHIFT STICK - ALUM. COVER
E8TZ7220D	→ SHIFT STICK RETAINER

We supply a full line of clutches for both light duty and heavy duty transmissions.



T10 STYLE
AMC®, FORD®, GM®, DODGE®
REAR WHEEL DRIVE CAR - 1957 - 1984

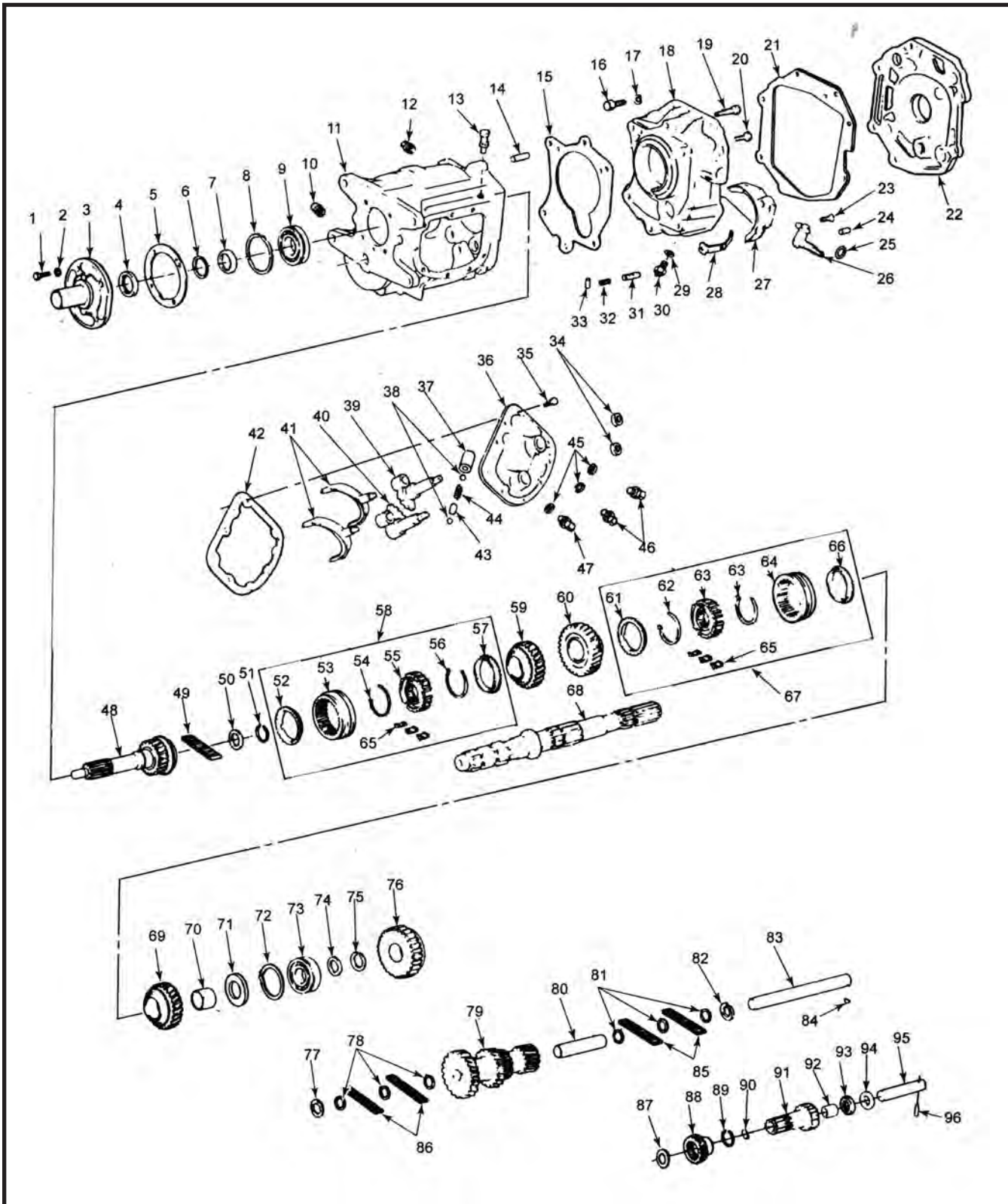

T10 STYLE (cont.)

ILL #	MIDWEST #	REF #	REPLACEMENT PART DESCRIPTION
3	T89C-6A	360806	RETAINER
4	7412S		SEAL FRONT - 1974-82
N.I.	9613S		SEAL REAR - 1974-82
9	1307L		BEARING FRONT - 1974-82
11			CASE - CALL FOR AVAILABILITY
18			REAR HOUSING - CALL FOR AVAILABILITY
27	T10-24		FORK REVERSE - 1974-82
34	T90A-108		SHIFTER SEALS
41	T10-23		MS 1-2-3-4 SHIFT FORK - ALL - 1957-74
41	T10W-23	360088	MS 1-2-3-4 SHIFT FORK - ALL - 1974-82
53/64	T10-15		SYNCHRO SLIDER (TORQUE LOCK DESIGN)
	T10S-15		SYNCHRO SLIDER (CUT- BACK DESIGN)
70	T10-33	GM3743439	MS 1ST GEAR SLEEVE - ALL - 1-7/8 X 2-1/16, HEK, FORD* - 7-65
		C2AZ7C115A	
70		1553076	MS 1ST GEAR SLEEVE
70	T10W-33	GM6260712	MS 1ST GEAR SLEEVE, 1-13/16 X 1-13/16, 1974-82
48	T10-16	3743447	MAIN DRIVE, 9" w/o THREAD, 2.20, S36-L27 - 1957-62
48	T10B-16	C2AZ7017D	MAIN DRIVE, 8-1/2", S36-L26 - 1962
48	T10A-16	GM3783316	MAIN DRIVE, 9", S36-L25T - 1962-65
48	T10E-16	GM1358578	MAIN DRIVE, 9" NICKEL, S26-L25T - 1963
48	T10C-16A	GM3819118	MAIN DRIVE, 9" THREAD, 2.20 1ST, S36-L25 - 1963
48	T10D-16	3792695	MAIN DRIVE, 9" THREAD, 2.54 1ST, S36-L25 - 1963
48	T10G-16	Dod 2400874	MAIN DRIVE, 11", S36-L25 - 1963
48	T10F-16	2400436	MAIN DRIVE, 11", S36-L27 - 1963
48	T10B-16A	C3AZ7017F	MAIN DRIVE, 8-1/2", S36-L26 - 1963
48	T10L-16	C3AZ7017G	MAIN DRIVE, 8-1/2" NICKEL, S36-L26 - 63-64
48	T10H-16	C30Z701E	MAIN DRIVE, 8-7/8", S36-L24 -1963-65
48	T10K-16	GM9771377	MAIN DRIVE, 9" NICKEL, S36-L27T - 1964-65
48	T10J-16	C30Z7017E	MAIN DRIVE, 8-7/8", S36-L26 - 1965
48	T10Q-16	C6ZZ7017A	MAIN DRIVE, 8-7/8", S36-L20T - 1966
48	T10P-16B	AMC3182320	MAIN DRIVE, 12-15/16", S36-L21T - 1965-66
48	T10P-16C	AMC3185638	MAIN DRIVE, 10-7/8", S36-L21T - 1966-67
48	T10T-16	AMC3189056	MAIN DRIVE, 2.64 RATIO, 10-7/8", S36-L20T - 1967-68
48	T10V-16B	AMC3199595	MAIN DRIVE, 2.23 RATIO, 10-7/8", S36-L22T - 1968-74 (4) I.D'S, 10 SPL.
48	T10W-16CH	360807	MAIN DRIVE, 9", 2.43 CLOSE RATIO, S36-L21T - 1974-79
48	T10W-16G	360814	MAIN DRIVE, 9", 2.64 WIDE RATIO, S36-L20T, 26 SPL. 1974-79
48	T10U-16B	14024319	MAIN DRIVE, 3:42 RATIO, S36-L17T - 26 SPL. 1980-82
48	T10Y-16B	14024318	MAIN DRIVE, 2:88 RATIO, S36-L19T, 10 SPL. 1982
52/57	T10W-14A	360812	1-2 RINGS, 3-4 RINGS - S-36
61/66			
53	T10-15		SYNCHRO SLIDER (TORQUE LOCK)
	T10S-15		SYNCHRO SLIDER (WIDE KEY / CUTBACK)
54/56/62/64	4682AN		SYNCHRO SPRING
58	AT16-2.5	1560752	MS 3RD & 4TH SYNCHRO - w/ RINGS
58	AT16-2.5	Dod 2408096	MS 3RD & 4TH SYNCHRO - w/ RINGS
58	AT16-2.5	AMC3182304	MS 3RD & 4TH SYNCHRO - w/ RINGS
58	AT16-2.5	GM3870789	MS 3RD & 4TH SYNCHRO - w/ RINGS, INT S6 SPL, S36T - 1957-67
58	AT16-2.5	C2AZ7124C	MS 3RD & 4TH SYNCHRO - w/ RINGS, INT S6 SPL, S36T
58	AT10-2.5CH		MS 3RD & 4TH SYNCHRO - w/ RINGS, 4-1/8 O.D., S6 SPL, S36T - 1974-82
59	AT10-11	GM3743452	MS 3RD, S36-L29T - GM* - BUSHING - 1957-60
59	T10H-11A	C30Z7B340B	MS 3RD, S36-L28T - 1960-65
59	T10E-11	1358576	MS 3RD, S36-L29T, NICKEL GM - C3AZ7B340A - 1960-65
59	T10J-11	387181	MS 3RD, S36-L29 w/o BUSHING - 1961-65
59	T10M-11	C3AZ7B340C	MS 3RD, S36-L27T, NICKEL - 1964
59	T10P-11	C6ZZ7B340A	MS 3RD, S36-L24T - MUSTANG - 1965-66
59	T10P-11	3182321	MS 3RD, S36-L24T - AMC* 8 CYL., 1965-74
59	T10T-11	3189055	MS 3RD, S36-L23T - AMC 8 CYL., 1967-68
59	T10S-11	474034	MS 3RD, S36-L22 - GM - 1974-79
59	T10U-11	3931524	MS 3RD, 3.42 RATIO, S36-L20T - 1979-85
59	T10X-11	14024322	MS 3RD, 2.88 RATIO, S36-L21T - CORVETTE - 1980-85
60	T10-31	C2AZ102A	MS 2ND, S36-L32T - 1957-62
60	T10-31	3743455	MS 2ND, S36-L30, NICKEL - 1957-63
60	T10M-31	C3AZ7102G	MS 2ND, S36-L29, NICKEL - 1963-65
60	T10E-31	C3AZ7102E	MS 2ND, S36-L30 NICKEL - 1963-66
60	T10H-31	C3AZ7102H	MS 2ND, S36-L30 - 1963-66
60	T10P-31	3182329	MS 2ND, S36-L26 - AMC 8 CYL., 1965-68
60	T10Q-31	3186012	MS 2ND, S36-L27 - AMC - 1/8" M/S - 1967-72
60	T10Q-31A	AMC3218972	MS 2ND GEAR, S36-L27 - AMC* - 1/4" M/S - 1973-74
		1358579	

T10 STYLE (cont.)

ILL #	MIDWEST #	REF #	REPLACEMENT PART DESCRIPTION
60	T10S-31A	360802	MS 2ND GEAR, S36-L25T - 1974-82
64	SEE #53		
65	T85B-13		SYNCHRO KEYS - ALL - CAST STRUTS
65	T16-13		SYNCHRO KEYS - ALL - STAMPED STRUTS
67	AT10-80CH	360801	1-2 SYNCHRONIZER w/o RINGS - CAST STRUTS - 1974-82
67	AT10-80	C2AZ7124N 1553071 2408105	1-2 SYNCHRONIZER - w/ RINGS, 10 SPL. 57-66
68	T10-2	3743450	MAIN SHAFT GM*, 21-5/16, S6-10-6-16, 3RD GEAR 1-3/8 O.D. - 1957-60
68	T10B-2	C2AZ7061A	MAIN SHAFT FORD*, 27-1/2, S6-10-6-28 - 1960-64
68	T10A-2	3783314	MAIN SHAFT GM, 21-5/16, S6-10-6-16, 3RD GEAR 1-1/2 O.D. - 1961-63
68	T10A-2A	535784	MAIN SHAFT, 24-17/32, S6-10-6-16, 1961-64
68	T10A-2C	1351894	MAIN SHAFT GM, 21-5/16, S6-10-6-23 BUICK - 1962-63
68	T10F-2	2400439	MAIN SHAFT DODGE*, 27-3/8, S6-10-10-23 - 1963
68	T10E-2	1355461	MAIN SHAFT GM, 21-5/16, S6-10-6 21 SPL. - BUICK* - 1963-65
68	T10H-2	C30Z7061C	MAIN SHAFT FORD, 25-9/16, S6-10-6-28 - 1963-65
68	T10D-2	1363459	MAIN SHAFT GM, 21-1/16, S6-10-6 27 SPL. - BUICK - 1964-65
68	T10H-2A	C3DZ7061B	MAIN SHAFT EARLY - 65, 23-5/8, S6-10-6-25, HEK-P - 1964-65
68	T10H-2B	C5DZ7061A	MAIN SHAFT FORD 8 CYL. 23-5/8, S6-10-6-28, HEK-U - 1965
68	T10P-2B	3182319	MAIN SHAFT AMC, 23-3/4, S6-10-6, 16 SPL., 1965-66
68	T10Q-2	C6ZZ7061A	MAIN SHAFT FORD, 23-5/8, S6-10-6-28 - 1966
68	T10P-2C	3185639	MAIN SHAFT AMC, 23-3/4, S6-10-6 28 SPL., 1967
68	T10S-2D	3218973	MAIN SHAFT AMC, 22-11/16, S6-10-10 28 SPL., 1973-74
68	T10W-2	6260713	MAIN SHAFT GM, 21-5/16, S6-10-32-32, 1974-75
68	T10A-2B	535872	MAIN SHAFT GM, 21-5/16, 6-10-6-16
68	T10W-2	6260713	MAIN SHAFT GM, 21-5/16, S6-10-32-32, 1974-82
68	T10W-2A	1403394	MAIN SHAFT GM, 21, S6-10-32-27, 1982
69	T10H-12	GM3743458 C2AZ72100C	MS 1ST GEAR GM, FORD, S36-L36T - 1957-66
69	T10E-12	C3AZ7100F	MS 1ST GEAR, S36-L3T NICKEL - GM, FORD - 1963-65
69	T10P-12	3182323 C6ZZ7A029C	MS 1ST GEAR, S36-L34T, FORD, AMC - 1965-74
69	T10W-12	GM360803	MS 1ST GEAR - 2.88 RATIO, S36-L34 - 1304080004 - 74-82
69	T10U-12	14013082	MS 1ST GEAR - 3.42 RATIO, S36-L30T - 1980-82
73	307L	N/A	BEARING REAR - 1974-82
76	T10-46A	C2AZ71003	MS REVERSE GM, FORD - 1-1/2 O.A., S-6 SPL. S39 - 1957-66
76	T10W-46	14024321	MS REVERSE GM, 1-1/2 O.A., S-32 SPL. S39 - 1974-82
79	T10-8	3746271	COUNTERSHAFT CLUSTER GEAR, R28-23-20-17, GM 2:20 RATIO
79	T10A-8	3783317	COUNTERSHAFT CLUSTER GEAR, R30-23-17, GM 2:54 RATIO
79	T10B-8	C2AZ7113C	COUNTERSHAFT CLUSTER GEAR, 6 & 8 CYL. 2:36 RATIO R29-23-20-17 - 1962 FORD
79	T10K-8	9771378 2408082	COUNTERSHAFT CLUSTER GEAR, 28-23-19-17, 2:20 RATIO 9310 STEEL - 1962-66
79	T10E-8	9771379	COUNTERSHAFT CLUSTER GEAR, 2:54 RATIO, 30-23-19-17 - 9310 STEEL - 1962-66
79	T10D-8	3817379 2408079	COUNTERSHAFT CLUSTER GEAR, 30-23-19-17 - 2:54 RATIO 8620 STEEL - 1962-66
79	T10J-8A	C3AZ7113L	COUNTERSHAFT CLUSTER GEAR, 8 CYL., 2:36 RATIO -29-23-19-17, 1963
79	T10L-8	C3AZ7113H	COUNTERSHAFT CLUSTER GEAR, 8 CYL., 3.90, 3RD GEAR, .830" NICKEL, 2:36 RATIO, 23-29-19-17, 1964
79	T10M-8	C3AZ7113K	COUNTERSHAFT CLUSTER GEAR, 8 CYL., 4.27, 2:36 RATIO NICKEL, R29-25-20-17T - 1964
79	T10H-8A	C30Z7113C	COUNTERSHAFT CLUSTER GEAR, 8 CYL., FORD HEK, GH 3RD GEAR (.830") - R31-24-19-17T, 2:74 RATIO - 1964-65
79	T10P-8	3182326	COUNTERSHAFT CLUSTER GEAR, AMC 2:43 RATIO, R27-21-19-8T 8 CYL., 1965-67
79	T10Q-8	C6ZZ7113A	COUNTERSHAFT CLUSTER GEAR, 8 CYL., FORD R28-21-18-18T - 1966
79	T10W-8B	1304077008 360810	COUNTERSHAFT CLUSTER GEAR, WIDE RATIO 2:64, 8 CYL., R28-23-20-18, 1974-75
79	T10W-8CH	1304077009	COUNTERSHAFT CLUSTER GEAR, CLOSE RATIO 2:43, R27-23-20-18, 1974-79
79	T10CC-8		COUNTERSHAFT CLUSTER GEAR - 1980-85
79	T10Y-8B	14024317	COUNTERSHAFT CLUSTER GEAR, 2.88 RATIO, R29-24-20-18T, 8 CYL. CORVETTE - 1980-85
83	T85B-3	GM3709300	COUNTERSHAFT, ALL - .8780" X 9-7/16, 1957-74
83	T10W-3	6260711	COUNTERSHAFT, ALL - .997 X 9-7/16, 1974-82
88	T10T-10	GM3936254	REVERSE IDLER, FRONT, S27 SPL. - L16 OR L17 - 1965-79
88	T10U-10	14013083	REVERSE IDLER, FRONT, S27 SPL. - L15 - 1980-82

T10 STYLE (cont.)

ILL #	MIDWEST #	REF #	REPLACEMENT PART DESCRIPTION
91	AT10-34C	AMC3132603	REVERSE IDLER, REAR, 28 SPL., L19 - 1960-82
93	T10W-79	14013087	THRUST BEARING - 1980-82
N.I.	WT297-90		INPUT NUT
N.I.	WT259-62		REAR BUSHING (SMALL)
N.I.	WT297-62		REAR BUSHING (LARGE)

KITS

T10R	➔	BEARING, SEAL & GASKET KIT - T10 - EARLY - 1973-DOWN
T10RMK	➔	BEARING, SEAL & GASKET MASTER KIT - EARLY 1973-DOWN
T10WR	➔	BEARING, SEAL & GASKET KIT - SUPER T10, 1974-ON
T10WRMK	➔	BEARING, SEAL & GASKET MASTER KIT - SUPER 10, 1974-ON
K10	➔	SEAL & GASKET KIT
K10W	➔	SEAL & GASKET KIT
GS10-55	➔	GASKET KIT
SP10-50	➔	SMALL PARTS KIT
SP10P-50	➔	SMALL PARTS KIT - 1965-74
SP10W-50	➔	SMALL PARTS KIT - 1974-82
T10-K	➔	KEY AND SPRING KIT (1-2, 3-4, STAMPED STEEL KEYS, NARROW HUMP)
T10-KS	➔	KEY AND SPRING KIT (1-2, 3-4, CAST IRON KEYS, WIDE HUMP)

T56 STYLE

**FORD® SVT MUSTANG, COBRA, CHEVY CORVETTE,
CAMARO, FIREBIRD, GTO, DODGE® VIPER, ASTON MARTIN,
DB7 VANTAGE, HOLDEN COMMODORE, AND MONARO**

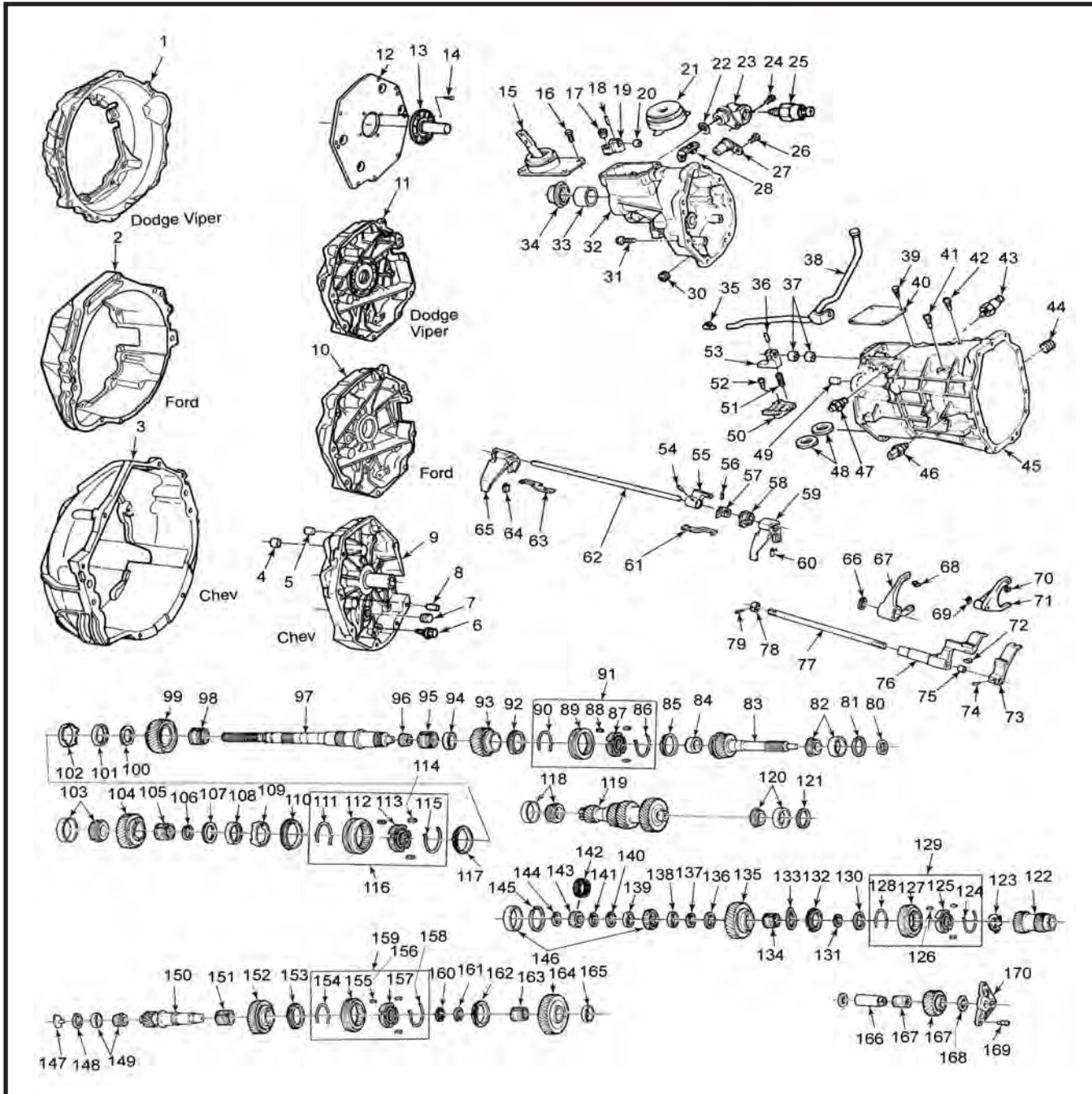

T56 STYLE (cont.)

ILL #	MIDWEST #	REF #	REPLACEMENT PART DESCRIPTION
1	1386212002		CLUTCH HOUSING, VIPER
2	1386212004		CLUTCH HOUSING, FORD*
3	1386212005		CLUTCH HOUSING, F-BODY - CHEVY LT2
3	1386712001		CLUTCH HOUSING, CHEVY F-BODY - CHEVY LT1
4	1386127001		BUSHING, TOP SHIFT RAIL
5	141199		DOWEL, CASE TO ADAPTER
6	1386183001		BOLT, FRONT ADAPTER
N.I.	1386034001		QUILL TUBE, THROWOUT BEARING, F-CAR
N.I.	1386034006		QUILL TUBE, THROWOUT BEARING, MUSTANG
7	1300052007		PLUG, INSPECTION
8	1300043009		DOWEL, ADAPTER TO CLUTCH HOUSING
9	1386672007		ADAPTER ASSY, CORVETTE
9	1386672008		ADAPTER ASSY, F-CAR - LS-1 - TAG # 017
9	1386672003		ADAPTER ASSY, F-CAR/HOLDEN - TAG# 009, 013, 016
9	1386672001		ADAPTER ASSY, F-CAR - TAG# 006, 007
10	1386672005		ADAPTER ASSY, FORD AFTERMARKET
11	1386672002		ADAPTER ASSY, VIPER
12	1386672006		ADAPTER PLATE, F-CAR AFTERMARKET
13	1352027007		RETAINER - FRONT BEARING, F-CAR CHEVY AFTERMARKET
13	1386034006		RETAINER - FRONT (FORD*)
14	1300183009		BOLT, FRONT RETAINER
15	1386598023		SHIFTER ASSY, F-CAR, HOLDEN
15	1386598031		SHIFTER ASSY, F-CAR, MUSTANG AFTERMARKET
15	1386598021		SHIFTER ASSY, VIPER
16	1351183001		BOLT, SHIFTER
17	1352127009		ISOLATOR CUP, REAR OFFSET LEVER
18	1332043004		ROLL PIN, OFFSET LEVER
19	1386098016		OFFSET LEVER, REAR
20	CONTACT VEHICLE MANUFACTURER		
21	CONTACT VEHICLE MANUFACTURER		
22	1300141120		O-RING, REV. LOCKOUT
23	1386097001		HOUSING, REV. LOCKOUT (ALL EXC. TAG# 003)
23	1386097003		HOUSING, REV. LOCKOUT - TAG# 003
N.I.	1386640002		REV. LOCKOUT ASSY (ALL EXC. TAG# 003)
N.I.	1386640003		REV. LOCKOUT ASSY - TAG# 003
24	1300183009		BOLT, REV. LOCKOUT
25	1386640008		SOLENOID, REV. LOCKOUT
26	11505117		BOLT - SPEED SENSOR
27	1386140006		SPEED SENSOR - F-CAR
27	1386140004		SPEED SENSOR - VIPER - TAG# 003, 005
27	1386140010		SPEED SENSOR - VIPER - TAG# 014, 018
28	CONTACT VEHICLE MANUFACTURER		
30	1300052007		PLUG, DRAIN
31	1386183001		BOLT, EXTENSION HOUSING
32	1386566018		EXTENSION HOUSING - MUSTANG AFTERMARKET - TAG# 012
32	1386566009		EXTENSION HOUSING - F-CAR, HOLDEN - TAG# 006, 007, 009, 013
32	1386566016		EXTENSION HOUSING - F-CAR AFTERMARKET - TAG# 011
32	1386566024		EXTENSION HOUSING - F-CAR - LS-1 - TAG# 016, 017
32	1386566011		EXTENSION HOUSING - VIPER - TAG# 003
32	1386566012		EXTENSION HOUSING - VIPER - TAG# 005, 014
32	1386566023		EXTENSION HOUSING - VIPER - TAG# 018
32	1386566019		EXTENSION HOUSING - CORVETTE - TAG# 015, 019
33	R10H-77M		BUSHING, EXTENSION HOUSING, F-CAR
33	1386127003		BUSHING, EXTENSION HOUSING - FORD, VIPER
34	1300044019		SEAL, OUTPUT - F-CAR
34	1300044020		SEAL, OUTPUT - MUSTANG
34	1300044017		SEAL, OUTPUT - VIPER
34	1300044022		SEAL, OUTPUT - CORVETTE INNER
34	1300044024		SEAL, OUTPUT - CORVETTE
35	1300072004		BREATHER
36	1332043004		ROLL PIN, FRONT OFFSET LEVER
37	1386127001		BUSHING, TOP RAIL
38	1386572002		VENT PIPE, CORVETTE AND VIPER
38	1386572005		VENT PIPE, ALL OTHERS
39	1351183001		BOLT, FRONT SHIFTER COVER PLATE
40	1386039001		COVER PLATE, FRONT SHIFTER
40	1386039002		COVER PLATE, FRONT SHIFTER, CORVETTE
41/42	1386183003		BOLT - SHIFT LEVER GUIDE
44	1300052007		PLUG, FILL

T56 STYLE (cont.)

ILL #	MIDWEST #	REF #	REPLACEMENT PART DESCRIPTION
45	1386565002		MAIN CASE ASSY: CHEVY F-CAR, HOLDEN AFTERMARKET - TAG# 006, 007, 011, 013, 029
45	1386565003		MAIN CASE ASSY: DODGE VIPER - ALL
45	1386565005		MAIN CASE ASSY: CHEVY CORVETTE, F-CAR -TAG# 009, 015, 016, 017
45	1386565007		MAIN CASE ASSY: FORD AFTERMARKET
46			CONTACT VEHICLE MANUFACTURER
47	1386640007		SOLENOID - SKIP SHIFT
48	4915E		MAGNET (2 REQ.)
49	141199		DOWEL PIN
50	1386014008		GUIDE PLATE
51	1386156004		SPRING, DETENT
52	1386183002		BOLT, GUIDE PLATE
53	1386098025		OFFSET LEVER, FRONT
54	1386043004		PIN, SELECTOR ARM
55	1386596011		SELECTOR ARM
56	1332043004		ROLL PIN
57	1386014007		SHIFT SHAFT SOCKET
58	1386096011		SHIFT SHAFT BLOCK
59	TNEC0843		UPDATED FORK 3-4 (OLD # 1386596014)
60	1386235001		FORK PAD 3-4 (2 REQ.)
61	1386190001		PLATE, SHIFT 3-4
62	1386100007		SHIFT RAIL, F-CAR
62	1386100008		SHIFT RAIL
62	1386100012		SHIFT RAIL, F-CAR & MUSTANG AFTERMARKET - TAG# 011, 012
62	1386100013		SHIFT RAIL, CORVETTE
63	1386190001		PLATE, SHIFT 1-2
64	1386235001		FORK PAD 1-2 (2 REQ.)
65	1386596013		FORK 1-2
66	1386139007		SNAP RING
67	1386596003		FORK 5-6 STAMPED 1386096903
68	1386235002		FORK PAD - REV.
69	1300139001		S-RING
70	1386235002		FORK PAD 5-6
71	1386596009		FORK, REV. STAMPED 1386096909
72	1386235002		FORK PAD
73	1386098010		SHIFT LEVER, REV.
74	1332043004		ROLL PIN
75	1386127001		BUSHING
76	1386598020		LEVER ASSY 5-6
77	1386100004		SHIFT RAIL, REV.
78	1386103003		COLLAR, REV. RAIL
79	1332043004		ROLL PIN
80	7412S		SEAL INPUT
81	1386037005 -037		SHIMS, INPUT (33 SIZES)
82	M88010/M88048		BEARING - INPUT CUP/CONE
83	1386585003		INPUT SHAFT - CHEVY - 29T, 1993 "LT1" w/ R 9-1/4"
83	1386585004		INPUT SHAFT - VIPER - 31T, 11.5"
83	1386585005		INPUT SHAFT - F-CAR, HOLDEN - TAG# 009, 013, 016 - 31T, 9-1/4" CHEVY LT1 - 1993-97
83	1386585007		INPUT SHAFT - CHEVY, 29T - AFT UNIT, 11-1/8"
83	1386585008		INPUT SHAFT - FORD AFTERMARKET - TAG# 012 - 9-3/4"
83	1386585009		INPUT SHAFT - CORVETTE - TAG# 015, 019 - 31T, CLOSE RATIO
83	1386585010		INPUT SHAFT - CHEVY LS1 1998-2000, 31T, 10-3/4" O.A.
84	LM12711		INPUT POCKET BEARING
86/90	1386156003		SYNCHRO SPRING 3-4
87	1386090004		SYNCHRO HUB 3-4 - 1 PC. RING
88	1351093001		SYNCHRO KEY 3-4
89	1386089002		SYNCHRO SLEEVE 3-4 - 1 PC. RING
91	1386590002		SYNCHRO ASSY 3-4 - ALL EXC. CORVETTE
91	1386590006		SYNCHRO ASSY 3-4 - CORVETTE
92/85	1386591003		SYNCHRO RING 3-4 - 1 PC. LINED DESIGN
92/85	1381591001		SYNCHRO RING 3-4 - TAG# 017 ONLY
92/85	1386091009		SYNCHRO BLOCKING RING 3RD GEAR - 3 PC. DESIGN
92/85	1386091011		SYNCHRO BLOCKING RING 4TH GEAR/INPUT - 3 PC. DESIGN
N.I.	1386525009		SYNCHRO RING 3RD GEAR DOUBLE LINED - 3 PC. DESIGN
N.I.	1386525010		SYNCHRO RING 4TH GEAR/INPUT DOUBLE LINED - 3-PC. DESIGN
N.I.	1386025002		SYNCHRO CONE - 3RD GEAR - 3 PC. DESIGN
N.I.	1386025003		SYNCHRO CONE - 4TH GEAR/INPUT - 3 PC. DESIGN
93	1386083006		3RD GEAR, M/S, F-CAR, CHEVY & FORD AFTERMARKET

T56 STYLE (cont.)

ILL #	MIDWEST #	REF #	REPLACEMENT PART DESCRIPTION
93	1386083007		2.97 RATIO - TAG# 007, 011, 012 - 37T STAMPED 906 3RD GEAR, M/S, F-CAR, VIPER - TAG# 003, 005, 009, 013, 014, 016, 017, 018 - 37T STAMPED 907
93	1386083008		3RD GEAR, M/S, CORVETTE - TAG# 015, 019
93	1386083005		3RD GEAR, M/S, F-CAR, 3.36 RATIO - TAG# 006
N.I.	1386053008		SPACER, 3RD GEAR NEEDLE BEARING - 1 PC. SYNCHRO RING
N.I.	1386193010		WASHER, 3RD GEAR NEEDLE BEARING - 3 PC. SYNCHRO RING
94	1386053008		3RD GEAR SPACER
95	1300132009		NEEDLE BEARING, 3RD GEAR
96	LM12749		BEARING CONE, INPUT POCKET
97	1386171003		MAIN SHAFT - CHEVY F-CAR, CHEVY AFTERMARKET - 27 SPL.
97	1386171004		MAIN SHAFT - DODGE VIPER
97	1386171005		MAIN SHAFT - FORD AFTERMARKET UNIT
97	1386171007		MAIN SHAFT - CORVETTE
98	1300132009		NEEDLE BEARING, 2ND GEAR
100	1386053006		SPACER, 2ND GEAR NEEDLE BEARING - 3 PC. SYNCHRO RING
99	1386082004		2ND GEAR, M/S, F-CAR, MUSTANG & F-CAR AFTERMARKET - TAG# 006, 007, 011, 012 - 41T
99	1386082005		2ND GEAR, M/S, VIPER, F-CAR, HOLDEN AFTERMARKET - TAG# 003, 005, 009, 013, 014, 016, 017, 018 - 43T
99	1386082006		2ND GEAR, M/S, CORVETTE - TAG# 015, 019
N.I.	1386193002		THRUST WASHER, 1ST & 2ND GEAR
101/108	1386091001		SYNCHRO CONE 1-2, 3 PC. DESIGN - EXC. CORVETTE
101/108	1386525008		SYNCHRO CONE 1-2, 3 PC. DESIGN - CORVETTE
102/109	1386525006		SYNCHRO RING, DOUBLE LINED 1-2 - (EXC. BELOW)
102/109	1386525007		SYNCHRO RING, DOUBLE LINED 1-2 - CORVETTE
102/109	1381525001		SYNCHRO RING, DOUBLE LINED 1-2 - TAG# 017
103	25520/25572		BEARING CUP/CONE - M/S CENTER
104	1386081005		1ST GEAR M/S, F-CAR, 3.36 RATIO - TAG# 006
104	1386081006		1ST GEAR, M/S, F-CAR, CHEVY & FORD AFTERMARKET - 2.97 RATIO - TAG# 007, 011, 012
104	1386081007		1ST GEAR, M/S, F-CAR, VIPER - TAG# 003, 005, 009, 013, 014, 016, 017, 018
104	1386081008		1ST GEAR, M/S, CORVETTE - TAG# 015, 019
105	1386132002		NEEDLE BEARING - 1ST GEAR
N.I.	1386053005		SPACER - 1ST GEAR NEEDLE BEARING
106	1300139015		SNAP RING 1-2 SYNCHRO HUB
111	1386156013		SYNCHRO SPRING 1-2 - CORVETTE
111/115	1386156001		SYNCHRO RING 1-2 - EXC. CORVETTE
112	1386089001		SYNCHRO SLEEVE 1-2
113	1386090001		SYNCHRO HUB 1-2
114	1386093001		SYNCHRO KEY 1-2 - EXC. CORVETTE
114	1386093002		SYNCHRO KEY 1-2 - CORVETTE
116	1386590001		SYNCHRO ASSY 1-2 (ALL EXC. CORVETTE)
116	1386590008		SYNCHRO ASSY 1-2, CORVETTE
117/110	1386091001		SYNCHRO BLOCKER RING 1-2 - EXC. CORVETTE
117/110	1386091008		SYNCHRO BLOCKER RING 1-2 - CORVETTE
118	32008		BEARING, COUNTERSHAFT REAR
119	1386077005		CLUSTER GEAR - F-CAR, 3.36 RATIO - TAG#006
119	1386077006		CLUSTER GEAR - F-CAR, CHEVY & FORD AFTERMARKET 2.97 RATIO - TAG# 007, 011, 012 - 37TH STAMPED 906
119	1386077008		CLUSTER GEAR - CORVETTE, F-CAR, VIPER - TAG# 003, 005, 009, 013, 019 - 37TH STAMPED 907
120	A5		COUNTER SHAFT BEARINGS - FRONT
122	1386070001		GEAR M/S 5-6 - .62 6TH GEAR - TAG# 006, 007, 011,012
123	1386040002		RETAINER, REV. STRUT
125	1386090003		HUB, REV. SYNCHRO
126	1351093001		KEY, REV. SYNCHRO (3 REQ.)
127	1386089003		SLEEVE, REV. SYNCHRO
128/124	1386156002		SPRING, REV. SYNCHRO (2 REQ.)
129	1386590004		SYNCHRO ASSY, REV.
130	1386193005		THRUST WASHER
131	1386139001		SNAP RING
132	1386091007		SYNCHRO RING, REV.
133	1386156005		WAVE RING, M/S REV.
134	1386132003		NEEDLE BEARING, M/S REV.
135	1386088003		REV. GEAR, M/S - 35T
136	1386193004		THRUST WASHER, REV.
137	1386139001		SNAP RING, M/S REV.

T56 STYLE (cont.)

ILL #	MIDWEST #	REF #	REPLACEMENT PART DESCRIPTION
137	1386090006		SYNCHRO HUB 3-4 - 3 PC. RING
138	1386193006		SPACER, M/S BEARING (EXC. BELOW)
138	1386193006		SPACER, M/S BEARING (CORVETTE/F-BODY- LS-1) TAG# 015, 016, 017, 019
140	1386139005		SNAP RING
141	1386139001		SNAP RING
142	1352110013		SPEEDO ROTOR - 17T
142	1386110002		SPEEDO ROTOR - 11T
142	1386110003		SPEEDO ROTOR - 10T
143	1386110004		SPEEDO GEAR - 7T - FORD
143	1351110002		SPEEDO GEAR - 7T - CHEVY
144	1000139031		SNAP RING - SPEEDO
145	1386139005		SNAP RING - M/S RACE
146	1386134001		BEARING, M/S REAR (RT5305S)
147	1386034002		FUNNEL, COUNTERSHAFT EXTENSION
148	1386037106-138		SHIMS, COUNTERSHAFT EXTENSION (33 SIZES)
149	LM12711/LM12749		BEARING, COUNTERSHAFT EXTENSION REAR
150	1386077007		COUNTERSHAFT EXTENSION - ALL EXC. CORVETTE
150	1386077009		COUNTERSHAFT EXTENSION - CORVETTE
151	1000132046		NEEDLE BEARING - 5TH GEAR
152	1386086003		5TH GEAR, C/S, F-CAR, MUSTANG & F-CAR AFTERMARKET - TAG# 006, 007, 011, 012
152	1386086004		5TH GEAR, C/S, VIPER, F-CAR, HOLDEN AFTERMARKET - TAG# 003, 005, 009, 013, 014, 016, 017, 018
152	1386086005		5TH GEAR, C/S - CORVETTE - TAG# 015, 019
155	1386089003		SLEEVE 5-6 SYNCHRO - 1 PC. RINGS
155	1386089004		SLEEVE 5-6 SYNCHRO - 3 PC. RINGS
156	1351093001		KEY, SYNCHRO (3 REQ.)
157	1386090007		HUB, 5-6 SYNCHRO - 3 PC. RINGS
157	1386090003		HUB, 5-6 SYNCHRO - 1 PC. RINGS
158/154	1386156002		SPRING, SYNCHRO (2 REQ.) - TAG# 015, 016, 017, 019)
159	1386590003		SYNCHRO ASSY 5-6 - (EXC. BELOW)
159	1386590007		SYNCHRO ASSY 5-6 - CORVETTE - 3-PC. RINGS
160	1386193001		SNAP RING 5-6 HUB
160	1386070602		GEAR M/S 5-6 - .50 6TH GEAR - (ALL OTHERS)
161	1386193008		THRUST WASHER, 6TH GEAR
162/153	1386591005		SYNCHRO RING 5-6 - 1 PC. DESIGN
N.I.	1386525010		SYNCHRO RING 5-6 - DOUBLE CONE - 3 PC. DESIGN
N.I.	1386025003		SYNCHRO RING 5-6 - INNER CONE - 3 PC. DESIGN
N.I.	1386193012		SPLINED WASHER 5-6 HUB - 3 PC. SYNCHRO RINGS
163	1386132005		NEEDLE BEARING - 6TH GEAR
164	1386087003		6TH GEAR C/S - .62 6TH GEAR - TAG# 006, 007, 011, 012 - (CAST - 903)
164	1386087004		6TH GEAR C/S - .50 6TH GEAR (EXC. CORVETTE) - CAST - 904
164	1386087005		6TH GEAR C/S - .50 6TH GEAR CORVETTE - TAG# 015, 019
165	1386053001		SPACER, 6TH GEAR NEEDLE BEARING (EXC. BELOW)
165	1386053007		SPACER, 6TH GEAR NEEDLE BEARING (CORVETTE - 2 REQ.)
166/170	1386193003		WASHER, THRUST WASHER
167	1386068001		SHAFT, REV. IDLER (EXC. BELOW)
167	1386068002		SHAFT, REV. IDLER (CORVETTE, F-BODY - LS-1) TAG# (015, 016, 017, 019)
168	1386132006		NEEDLE BEARING, REV. IDLER
169	1386084001		REVERSE IDLER GEAR
171	1386183002		BOLT, REV. IDLER BRACKET (3 REQ.)
172	1386185001		BRACKET, REV. IDLER (EXC. BELOW)
172	1386185002		BRACKET, REV. IDLER (CORVETTE, F-BODY - LS-1)

T56 STYLE (cont.)

KITS

T56R	→	BEARING, GASKET & SEAL KIT
T56RMK	→	BEARING MASTER KIT - EXCEPT CORVETTE
T56RAMK	→	BEARING MASTER KIT - CORVETTE
RK56	→	SYNCHRO RING KIT - EXCEPT CORVETTE
RK56A	→	SYNCHRO RING KIT - CORVETTE
SP56-50	→	SMALL PARTS KIT
SP56-56A	→	SMALL PARTS KIT
1386000011	→	TRANS ASSY - RETROFIT F-BODY - REPLACES T5
1386000012	→	TRANS ASSY - RETROFIT MUSTANG - REPLACES T5

G360 STYLE

DODGE® 1988-93, RAM 3500, D250/350

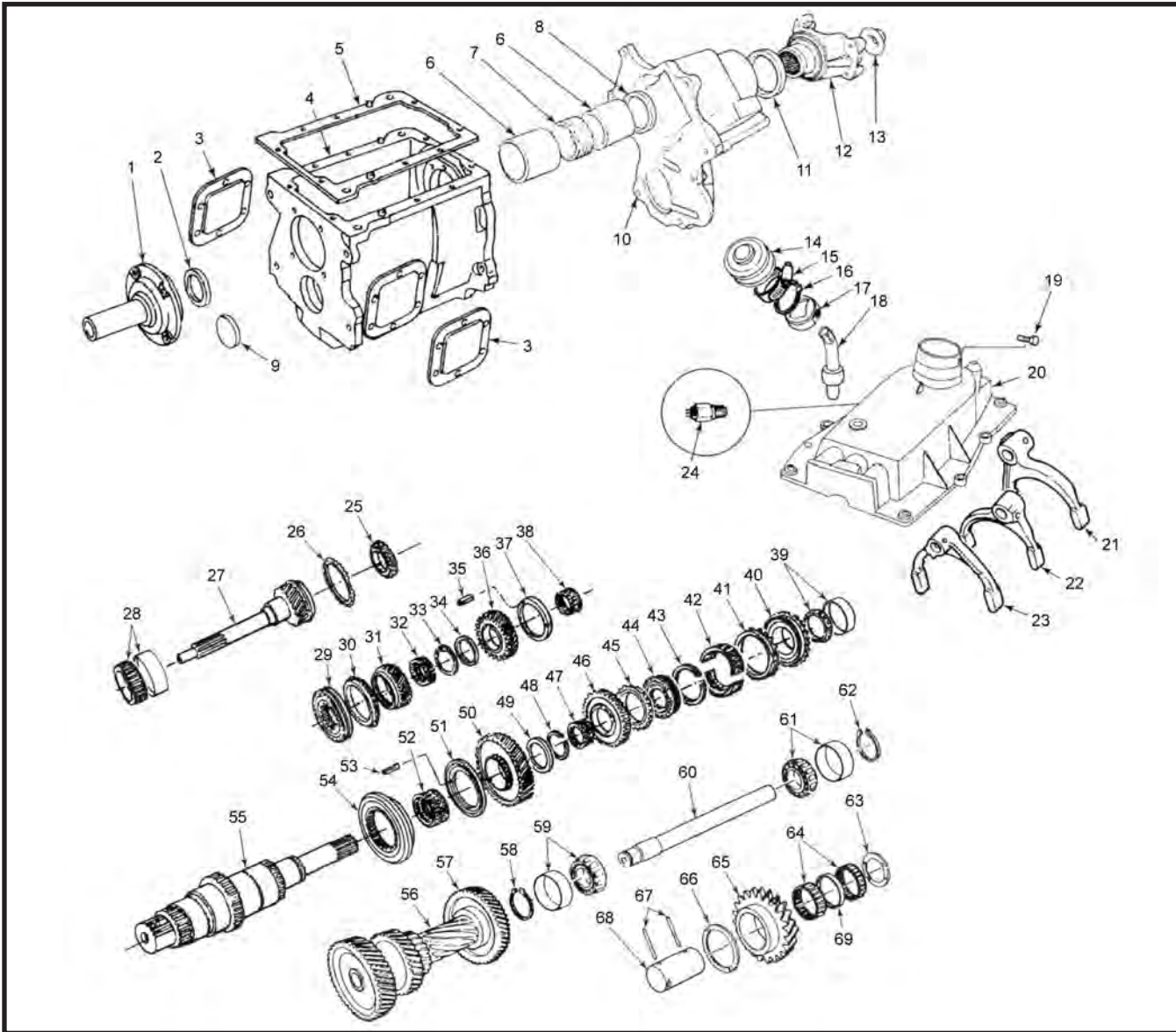

ILL #	MIDWEST #	REF #	REPLACEMENT PART DESCRIPTION
1	G360-6	4740145	FRONT BEARING RETAINER
2	F145B		FRONT SEAL
3	4740228		PTO COVER (2 REQ.)
4	4740733		MAIN CASE (IRON)
5	G360-TOP		GASKET - TOP COVER
6	4740164		SPACER (2 REQ.)
7	4549212		SPEEDOMETER GEAR
8	4728616		SEAL, EXTENSION HOUSING
9	5152		CAP - FRONT COUNTER BEARING
10	4740167		EXTENSION HOUSING 4X4
10	4740165		EXTENSION HOUSING 2WD
11	471424	4504583	REAR SEAL 2WD
11	E2132	MD703743	REAR SEAL 4X4
12	4504584		YOKE
13	4504585		NUT - M/S REAR
19	G360-P1		SHIFTER PIN

G360 STYLE (cont.)

ILL #	MIDWEST #	REF #	REPLACEMENT PART DESCRIPTION
20	4740035		SHIFT COVER - LOADED
21	G360-23B		SHIFT FORK 5-REV.
22	G360-23		SHIFT FORK 1-2
23	G360-23A		SHIFT FORK 3-4
24	4504586		SWITCH, BACKUP LIGHT
25	32008AX		BEARING - INPUT POCKET
26			SEE ITEM #30
27	G360-16	4728615	INPUT SHAFT - 25T
28	JM205110		INPUT BEARING CUP
28	JM205149		INPUT BEARING RACE
29	G360-2.5	4740151	SYNCHRO ASSY - 3-4
30/26	WT290-14		SYNCHRO RING 3-4
31	G360-11	4740150	3RD GEAR M/S - 30T
32	K55X63X29.5		NEEDLE BEARING - M/S 3RD GEAR
34	4740149		SPACER - M/S 2ND GEAR
36	G360-21	4740148	2ND GEAR - M/S
37	G360-83		SYNCHRO RING 1-2
39	25572		BEARING CONE - M/S REAR
39	25528		BEARING CUP - M/S REAR
40	G360-18	4740163	5TH GEAR M/S - 21T
41			SEE #45
42	K43X48X37.5		NEEDLE BEARING - M/S 5TH
44	4740161		SYNCHRO ASSY - 5/REV.
45/41	WT290-14	4741277	SYNCHRO RING - 5/REV.
46	4740160		REV. GEAR - M/S
47			NEEDLE BEARING - M/S REV. GEAR
49	4740159		SPACER - M/S 1ST GEAR
50	4740156		1ST GEAR M/S
51/37	G360-83		SYNCHRO RING 1-2
52			NEEDLE BEARING - M/S 1ST GEAR
54	G360-80	4740152	SYNCHRO HUB / SLEEVE 1-2
55	G360-2	4740146	MAIN SHAFT 2WD
55	G360-2A	4740147	MAIN SHAFT 4X4
56	G360-8	4740137	CLUSTER GEAR (INCLUDES 5TH GEAR) 44-33-21-14-48
57	G360-19		5TH GEAR C/S - 48T
58	G360-97		SNAP RING
59/61	30305JR		BEARING - C/S FRONT/REAR
60	G360-3	4740741	COUNTERSHAFT
61			SEE #59
62	G360-97		SNAP RING
64	4741342		NEEDLE BEARING - REV. IDLER
65	4740144		REV. IDLER GEAR
66	4740139		THRUST WASHER - REV. IDLER
68	4740138		REV. IDLER SHAFT

KITS

G360K	➔	1-2 SYNCHRO SPRINGS & BALLS KIT
T261R	➔	BEARING KIT
RK360	➔	SYNCHRO RING KIT
PTO-55	➔	PTO COVER GASKET
WT290K	➔	3-4, 5-REV. SYNCHRO KEYS AND SPRING KIT

NP535 STYLE DODGE® D100/150, 1987-92 DAKOTA

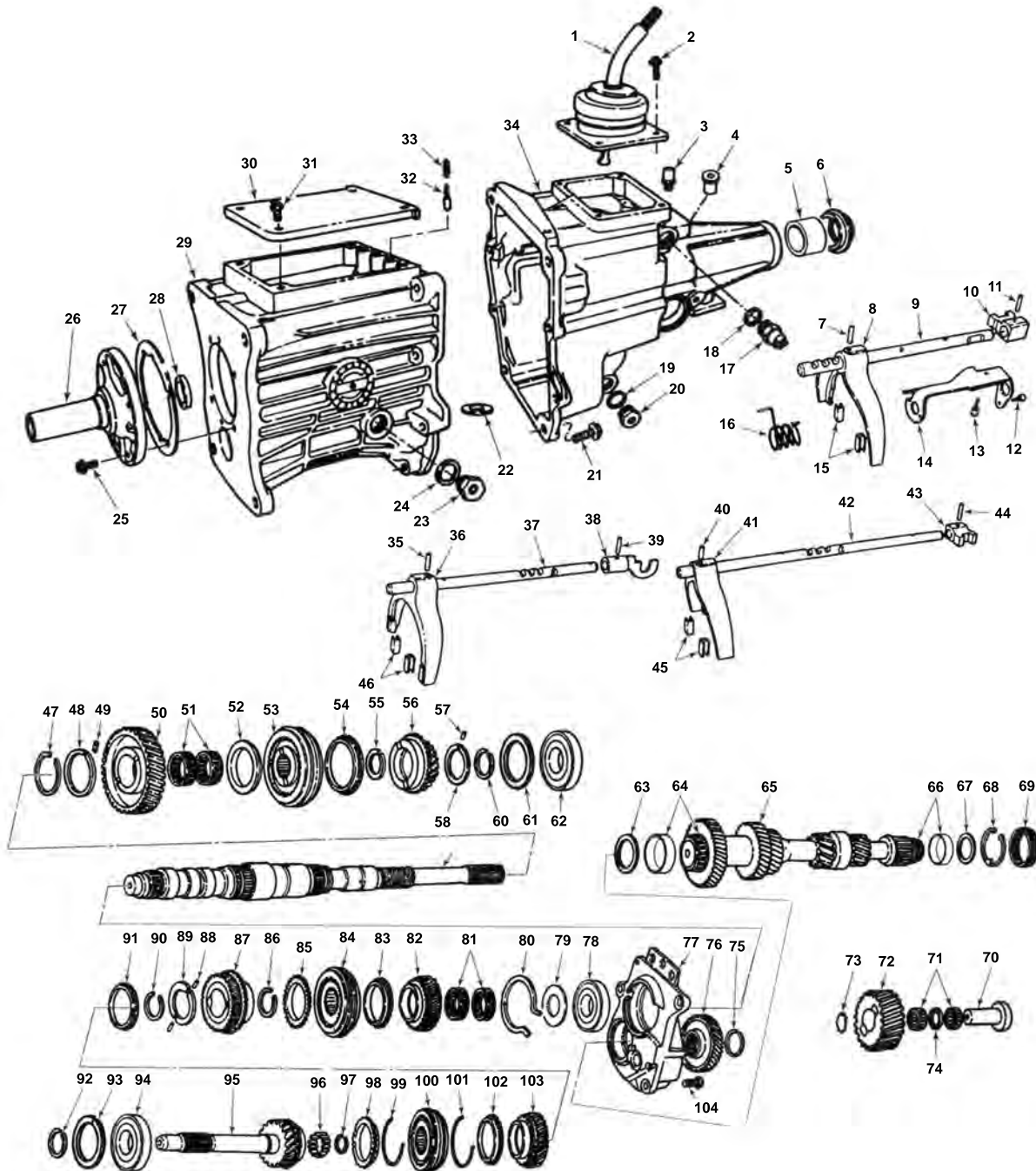

ILL #	MIDWEST #	REF #	REPLACEMENT PART DESCRIPTION
1	4338332		SHIFTER ASSY - B VAN
1	4338145		SHIFTER ASSY - DAKOTA
1	4338331		SHIFTER ASSY - D1500 TRUCK
3	2124715		BREATHER
5	WT243-62B	2801726	EXT. HOUSING BUSHING
6	2506	4058047	REAR SEAL 2WD
6	NV4269956	4269956	REAR SEAL 4WD
7	442934		ROLL PIN - SHIFTER FORK - ALL (3 REQ.)

NP535 STYLE (cont.)

ILL #	MIDWEST #	REF #	REPLACEMENT PART DESCRIPTION
8	4338027		SHIFT FORK - WITH PADS 5-REV.
9	4338210		SHIFT RAIL - 5-REV.
10	4338146		SHIFT LUG 1-2 - 5-REV. RAIL
11	442931		ROLL PIN - SHIFT LUG - ALL (3 REQ.)
12	4338244		BUMPER - 5-REV. BLOCKER
13	4338244		BUMPER - 5-REV. BLOCKER
14	4338292		BLOCKER - 5-REV. RAIL
15	4295519		FORK PADS - ALL (6 REQ.)
16	4505490		SPRING - 5-REV. RETURN
17	4373814		SWITCH - REV. LIGHT
18	NV89279	1302807	GASKET - REV. LIGHT SWITCH
19/20	4202535		PLUG w/ WASHER
21	6501566		BOLT
22	3681601		MAGNET
23/24	4202535		PLUG w/ WASHER
25	6500318		BOLT
26	4338298	535-6	FRONT BEARING RETAINER
27	4338302		GASKET - FRONT RETAINER
28	9376	2801692	SEAL - INPUT SHAFT
29	4338261		MAIN CASE
30	4338230		TOP COVER - MAIN CASE
31	6500318		BOLT - TOP COVER (4 REQ.)
32	4338071		PLUNGER - SHIFT RAIL POPPET
33	53006657		SPRING - SHIFT RAIL POPPET
34	4338264		EXTENSION HOUSING 2WD
34	4338236		ADAPTER HOUSING 4WD
35	442934		ROLL PIN - SHIFT FORK - ALL (3 REQ.)
36	4338027		SHIFT FORK w/ PADS - 5-REV.
37	4338209		SHIFT RAIL 3-4
38	4338246		SHIFT LUG 3-4
40	442934		ROLL PIN - SHIFT FORK - ALL (3 REQ.)
41	4338013		SHIFT FORK w/ PADS 1-2
42	4338208		SHIFT RAIL 1-2
43	4338146		SHIFT LUG 1-2 RAIL
44	442931		ROLL PIN - SHIFT LUG - ALL (3 REQ.)
45	4295519		FORK PADS - ALL (6 REQ.)
46	4295519		FORK PADS - ALL (6 REQ.)
47	6501206		SNAP RING
48	4338098		THRUST WASHER
49	4338009		PIN
50	4338132R	535-36	REVERSE GEAR M/S - 38T
51	K40X45X17	4338058	NEEDLE BEARING - REV. GEAR M/S (2 REQ.)
52	4338180		RETAINING RING
53	4338225R	535-2.5	5-REV. HUB & SLEEVE ONLY
54	4446061	T1102-14	SYNCHRO RING 5TH GEAR
55	6025755		SNAP RING
56	4338129	535-18	5TH GEAR M/S - 23T
57	2952592	99086	PIN - 5TH GEAR THRUST WASHER
58	4338068		THRUST WASHER
59	4338194R	535-2	MAIN SHAFT 4X4
59	4338192		MAIN SHAFT 2WD
60	6025755		SNAP RING
61	6501246		SNAP RING
62	207L	163371B	BEARING - M/S REAR
63	4338306		O-RING - FRONT C/S BEARING
64	LM67010BCE	4338304	BEARING FRONT C/S CUP
64	LM67048	4338305	BEARING FRONT CS CONE
65	4504567R	4504567	KIT C/S WITH 5TH GEAR - KEYED STYLE (UPDATE)
65	4338375R		COUNTERSHAFT - 1989-92 - KEYED STYLE - USE 4504567R
66	LM11910 / LM11949	4338311 / 4338312	BEARING REAR C/S CUP AND CONE

NP535 STYLE (cont.)

ILL #	MIDWEST #	REF #	REPLACEMENT PART DESCRIPTION
67			WASHER
68	6033129		SNAP RING
69	BH3312	4338228	NEEDLE BEARING - C/S CENTER
70	4504576		REV. IDLER GEAR SHAFT - 1987-88
70	4505408		REV. IDLER GEAR SHAFT - 1989-92 - USE 4504576
71	K20X26X13A	4338079	NEEDLE BEARING - REV. IDLER GEAR (2 REQ.)
72	4338131		IDLER GEAR - 22T
73	6501152		SNAP RING - 1987-88
73	6501149		SNAP RING - 1989-92
74	4338159		SPACER - REV. IDLER NEEDLE BEARINGS
75	6501207		SNAP RING - 1987 DAKOTA
75	6501206		SNAP RING - 1988-92
76	4338374R		5TH GEAR C/S - KEYED STYLE - 1989-92 - USE 4504567R
77	4504576		MID-PLATE - 1987-88
77	4338373		MID-PLATE - 1989-92
78	208L	4338254	MAIN SHAFT BEARING
79	4338032		THRUST WASHER
80	6501168		RETAINING RING
81	4338031		NEEDLE BEARING 1ST GEAR M/S (2 REQ.)
82	4338152	535-12	1ST GEAR M/S - 37T
83	4446060	T1102-14B	SYNCHRO RING 1-2
84	4338224	535-80	SYNCHRONIZER ASSY 1-2 - LESS RINGS
85	4446060	T1102-14B	SYNCHRO RING 1-2
86	6024131	6024131	SNAP RING
87	4338202	4338202	2ND GEAR M/S - 36T
88	4443193	4443193	PIN AND THRUST WASHER PACKAGE
89	4338234		THRUST WASHER - SPLIT
90	6025755		SNAP RING
91	5222749		THRUST WASHER
92	6025755		SNAP RING - INPUT BEARING - SMALL
93	2124518		SNAP RING - INPUT BEARING - LARGE
94	307L	4338272	BEARING - INPUT SHAFT
95	4338190R	535-16	INPUT SHAFT - ALL
96	QBR23549	1949834	POCKET BEARING - INPUT (16 REQ.)
97	6025755		SNAP RING
98	4446061	T1102-14	SYNCHRO RING 3-4
99	4202124		SYNCHRO SPRING 3-4 (2 REQ.)
100	4338225R	535-2.5	SYNCHRO 3-4 - HUB + SLEEVE ONLY
103	4338017	535-11	3RD GEAR - MAIN SHAFT

KITS

T535R	→	BEARING, SEAL & GASKET KIT
T535RMK	→	BEARING, SEAL & GASKET MASTER KIT - RINGS
RK535	→	RINGS - ALL
SP535-50	→	SMALL PARTS KIT
4338302	→	FRONT GASKET
WT535-K	→	KEY AND SPRING KIT, 3,4,5/R

NV5600 STYLE

DODGE® R3500 - 1998 & UP

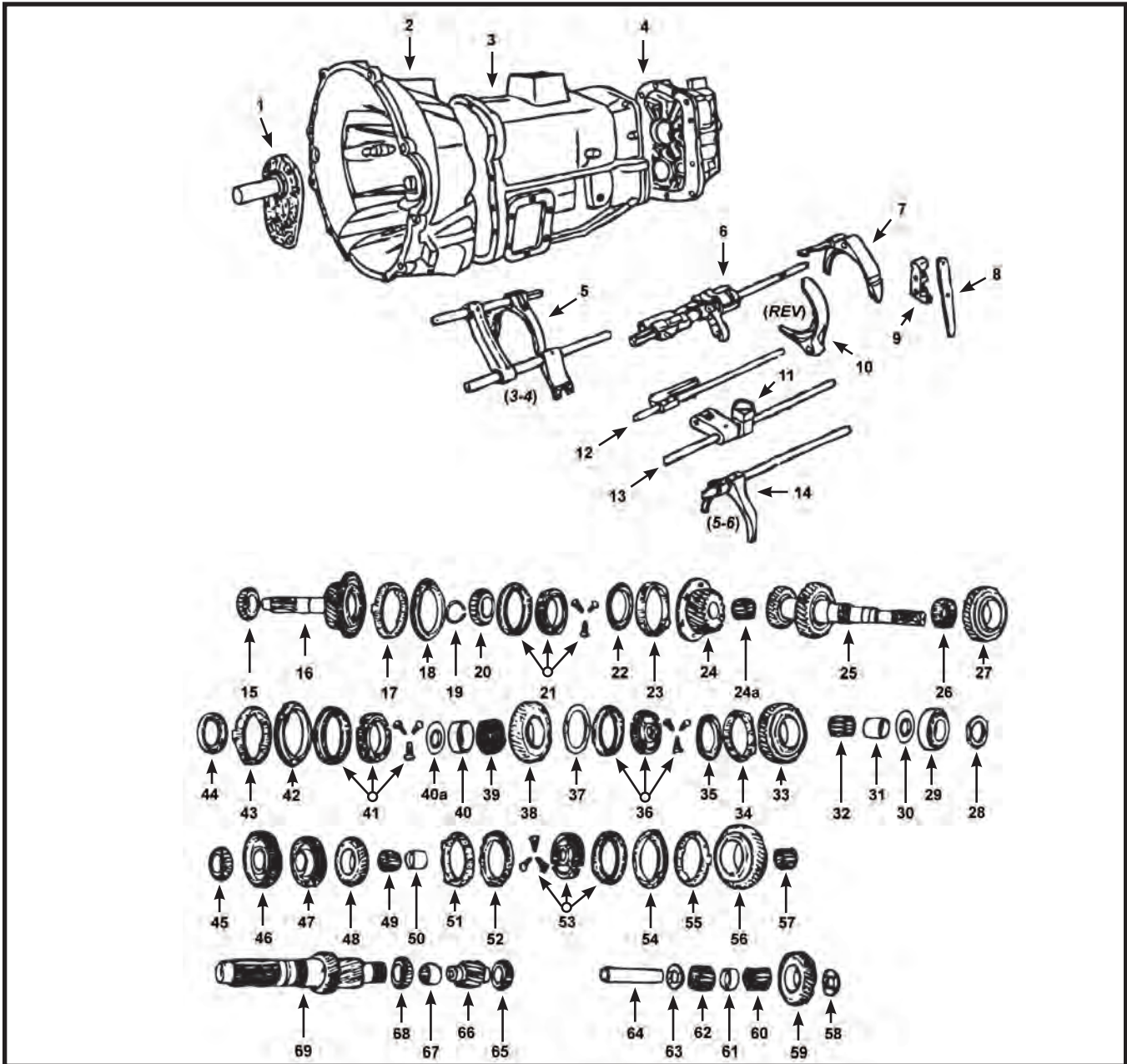

ILL #	MIDWEST #	REF #	REPLACEMENT PART DESCRIPTION
1	NV22863	5066016AA	FRONT BEARING RETAINER
2	NV22732	5003582AA	BELL HOUSING ASSY
3	NV22725	5003578AA	MAIN CASE ASSY
N.I.	NV21041	4882280 / 12540348	DRAIN PLUG
4	NV22737		REAR EXTENSION HOUSING ASSY
4	NV22738		REAR EXTENSION HOUSING ASSY
4	NV23078		REAR EXTENSION HOUSING ASSY
4	NV23079		REAR EXTENSION HOUSING ASSY
5	NV26702	5010090AA	SHIFT FORK & RAIL ASSY 3-4
N.I.	NV22728		BUSHING
6	NV27846	5010079AA	RAIL 1-2
7	NV26703	5010091AA	SHIFT FORK 1-2
10	NV22884	5012128AA	SHIFT FORK, REVERSE
11	NV22813	5010086AA	SOCKET - SHIFT SHAFT
12	NV25413	5010097AA	RAIL - REV.
13	NV27843	5010078AA	RAIL - 3-4

NV5600 STYLE (cont.)

ILL #	MIDWEST #	REF #	REPLACEMENT PART DESCRIPTION
14	NV26704	5010093AA	SHIFT FORK & RAIL ASSY 5TH
N.I.	NV35662		COVER, PTO
15	HM804810 / HM804849	5010047AA	BEARING, INPUT CUP/CONE
16	NV22748	5010045AA	INPUT SHAFT 5TH GEAR - 1-3/8" SPLINE - LATE
16	NV38179	5066027AA	INPUT SHAFT - 1-1/4" SPLINE - EARLY
17/23/34/ 43/55/51	NV44548	5083021AA	1-6 REV. MIDDLE SYNCHRO RING (FIBER)
18/22/35/	NV22761	5083021AA	1-6 REV. OUT SYNCHRO RING (METAL)
20	32305	5010057AA	BEARING, INPUT POCKET CUP/CONE
21	NV22762	5010055AA	SYNCHRO ASSY, 5TH
24	NV22756	5066015AA	6TH GEAR, M/S
24A	NV22759		6TH GEAR, NEEDLE BEARINGS
25	NV26222	5010049AA	MAIN SHAFT 2WD
25	NV26221	5010050AA	MAIN SHAFT 4X4
26	45220 / 45290	5010059AA	BEARING, M/S CENTER CUP/CONE
27	NV22720	5066010AA	2ND GEAR, M/S
28	NV27663		NUT, 2WD
29	209L	5012132AA	BEARING, M/S REAR
30	NV22889	5012131AA	WASHER - REV. THRUST
31	NV27340	5012129AA	RACE, M/S REV. NEEDLE BEARING
32	5017924AA		NEEDLE BEARING, M/S REV.
33	NV22886	5012130AA	REV. GEAR ASSY, M/S
36	NV22880	5012125AA	SYNCHRO ASSY, REV.
36A	NV22881		HUB, REV
36B	NV45140		SLIDER, REV
38	NV22784	5066009AA	1ST GEAR, M/S
39		5010059AA	1ST GEAR NEEDLE BEARING
40	NV27341	5010077AA	1ST GEAR SLEEVE
40A	NV22787		1-2 THRUST WASHER
41	NV22777	5010062AA	SYNCHRO ASSY, 1-2
44	NV32470	5015202AA	1-2 SYNCHRO BLOCKING RING
45	LM102910/LM102949	5010075AA	BEARING, C/S FRONT CUP/CONE
46	NV26164	5010073AA	DRIVE GEAR, C/S 5TH GEAR
47	NV26165	5010074AA	6TH GEAR, C/S
48	NV22803	5010072AA	4TH GEAR, C/S
49			NEEDLE BEARING, C/S 4TH GEAR
50			SLEEVE, NEEDLE BEARING, C/S 4TH GEAR
53	NV22799	5010070AA	SYNCHRO ASSY 3-4
56	NV22794	5010069AA	3RD GEAR, C/S
57			NEEDLE BEARING, C/S 3RD GEAR
58		5012118AA	IDLER GEAR WASHER
59	NV22873	5012121AA	REV. IDLER GEAR
61	NV22872	5012120AA	SPACER - REV. IDLER
62/60		5012119AA	IDLER GEAR BEARING
63	NV22870	5012118AA	WASHER - REV. IDLER
64	NV22869	5012117AA	SHAFT, REV. IDLER
65	A5	5012124AA	BEARING, C/S REAR CUP/CONE
66	NV22876	5012122AA	COUNTER REV. GEAR
67		5010123AA	REV. SLEEVE
68	25520/25590	4798769	BEARING, C/S CENTER CUP/CONE
69	NV26166	5010066AA	COUNTERSHAFT
N.I.	710058		4X4 REAR SEAL
N.I.	38X50X7		INPUT SEAL
N.I.	4741		2WD REAR AXLE
N.I.	22759		6TH GEAR NEEDLE BEARING
N.I.	NV22789		1ST GEAR SNAP RING KIT

KITS

T492R	→ BEARING GASKET & SEAL KIT
T492RAMK	→ BEARING GASKET & SEAL MASTER KIT WITH RINGS - EARLY DESIGN
T492RMK	→ BEARING GASKET & SEAL MASTER KIT WITH RINGS
NV5600-SK	→ INPUT SHIM KIT

FM145 / FM146 / FM132 STYLE MITSUBISHI®, FORD® BRONCO II, RANGER 1986-92

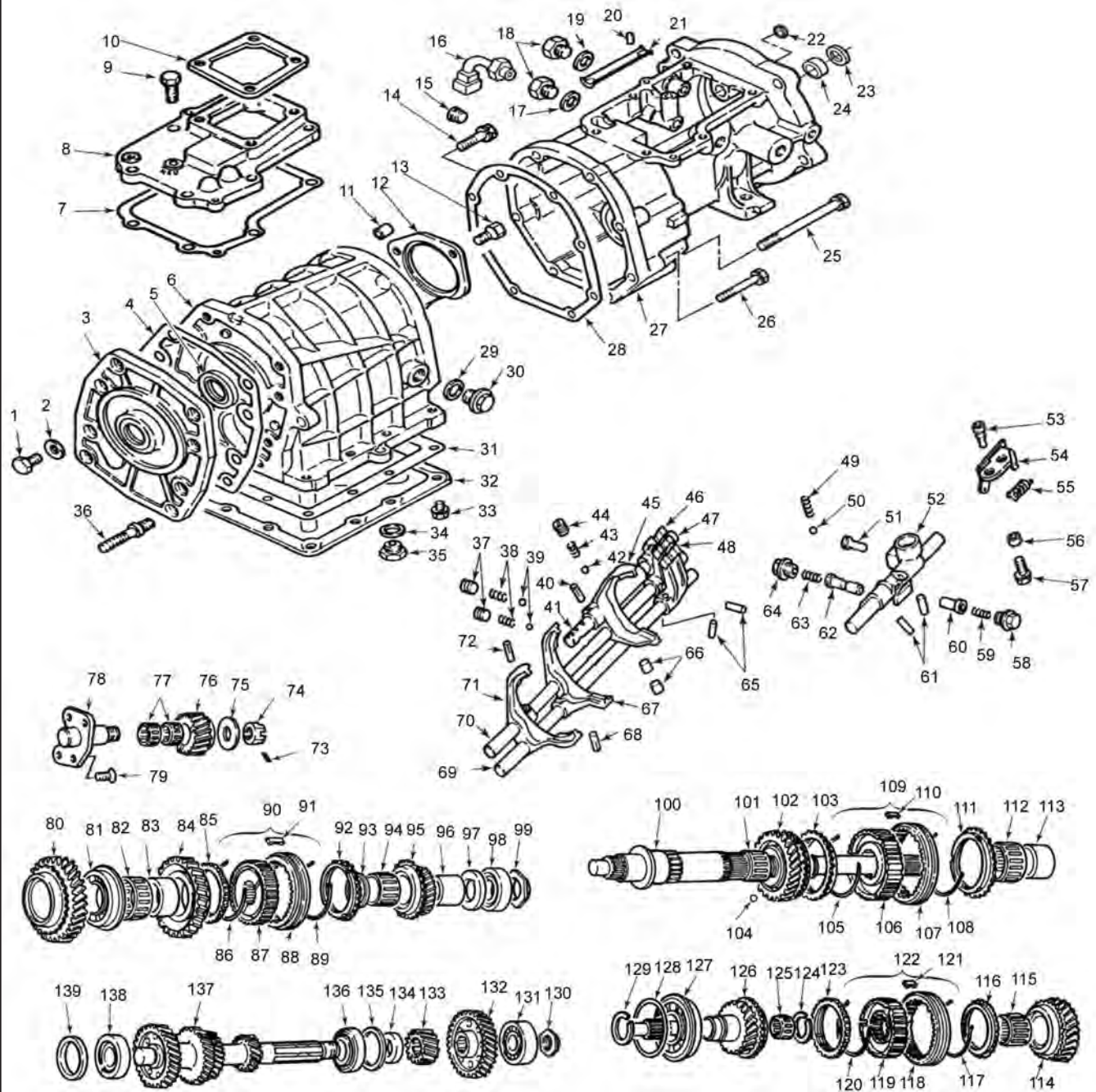

ILL #	MIDWEST #	REF #	REPLACEMENT PART DESCRIPTION
1	E5TZ7A443G		BOLT - FRONT COVER
2	E5TZ7D448A		WASHER
3	E5TZ7050A		FRONT BEARING RETAINER - FM145
3	E8TZ7050A		FRONT BEARING RETAINER - FM146
3	E8TZ7050C		FRONT BEARING RETAINER, FM146
4	E5TZ7051A		BEARING RETAINER, FRONT GASKET 1985-92
5	1981	E5TZ7052A	SEAL, FRONT INPUT
5	11615	E5TZ7052D	SEAL, FRONT INPUT
6	E5TZ7005A		MAIN CASE FM145
6	E8TZ7005E		MAIN CASE FM146

FM145 / FM146 / FM132 STYLE (cont.)

ILL #	MIDWEST #	REF #	REPLACEMENT PART DESCRIPTION
7	E5TZ7185A		TOP COVER GASKET - 1986-87 BRONCO II, RANGER 1988-89 -E67A-FB
7	E8TZ7185A		TOP COVER GASKET - 1988-89 BRONCO II, RANGER - E87A-AEA, 1990 BRONCO II, 1990-92 RANGER 4WD
7	F0TZ7185A		TOP COVER GASKET - 1990 BRONCO II, 1990-91 RANGER 2WD
8	E5TZ7203A		TOP COVER - BRONCO II, RANGER FM145 - 357A-KB
8	E5TZ7203B		TOP COVER - FM146 - E57A-KC, E67A-FA, E67A-FB
8	E5TZ7118A		BEARING - MAIN SHAFT CENTER
8	E8TZ7203A		TOP COVER - E87A-AEA - 1990 BRONCO II 4WD, 1990-92 RANGER 4WD
8	F0TZ7203A		TOP COVER - 1990 BRONCO II, 1990-91 RANGER 2WD
9	E5TZ7A443E		TOP COVER BOLT
10	E8TZ7207A		GASKET - SHIFTER
11	E5TZ7D362A		BUSHING
12	E5TZ7085A		REAR BEARING RETAINER
12	F0TZ7085A		REAR BEARING RETAINER
13	E5TZ7C2104		BOLT - REAR BEARING RETAINER
14	E5TZ7A443A		BOLT EXTENSION HOUSING - SHORT
14	E5TZ7A443B		BOLT EXTENSION HOUSING - MEDIUM
14	E5TZ7A443C		BOLT EXTENSION HOUSING - LONG
15	35305557		PLUG
16	E5TZ7G072A		SWITCH - NEUTRAL SAFETY
17	E5TZ7L101C		GASKET - NEUTRAL SAFETY SWITCH
18	E5TZ7306A		PLUG - SHIFT INDICATOR 9/16 X 18 THD
18	E5TZ7306B		PLUG - NEUTRAL SWITCH 5/8 X 18 THD
18	E5TZ7306C		PLUG - NEUTRAL SWITCH
19	E5TZ7B426A		GASKET - SHIFT INDICATOR SWITCH
21	E5TZ74174A		GUTTER
22	E8TZ7K381A		CUP PLUG
23	1987	E8TZ7052F	REAR SEAL
24	E8TZ7B317A		SLEEVE - REAR SEAL
27	E5TZ7A039A		EXTENSION HOUSING 1986-89 BRONCO II, RANGER - E57A-KB
27	E8TZ7A039G		EXTENSION HOUSING 1986-89 BRONCO II, RANGER - E87A-AEA
27	E5TZ7A039J		EXTENSION HOUSING 1986-89 BRONCO II, RANGER - E57A-KC, E67A-FA, E67A-FB
27	E8TZ7A039M		EXTENSION HOUSING 1990 BRONCO II, RANGER 1990-92 4X4
27	F0TZ7A039C		EXTENSION HOUSING 1990 BRONCO II, RANGER 2WD
28	E5TZ7086A		EXTENSION HOUSING GASKET
28	E5TZ7B353A		EXTENSION HOUSING GASKET
29	E5TZ7L101A		GASKET - PLUG
30	E5TZ7A010A		FILL PLUG
31	E5TZ7166A		OIL PAN GASKET
32	E5TZ7165A		OIL PAN
32	F0TZ7165A		OIL PAN
33	E5TZ7A443D		BOLT - OIL PAN (12 REQ.)
34	E5TZ7L101A		GASKET - DRAIN PLUG
35	E5TZ7A010A		DRAIN PLUG
36	E5TZ7C207A		STUD - BELL HOUSING 43mm LONG
36	E8TZ7C207A		STUD - BELL HOUSING 55mm LONG
37			SEE ITEM #42
38			SEE ITEM #43
39			SEE ITEM #44
41	E5TZ7242A		SHIFT RAIL ASSY - 5-REV. - 1986-87 BRONCO II, 1988-92 RANGER - 367A-FB
41	E8TZ7241C		SHIFT RAIL ASSY - 5-REV. 1988-92 - E87A-AEA
42/37	E8TZ7235C		PLUG - SHIFT PLUNGER
43/38	E5TZ7234A		POPPET SPRING - FM145
43/38	E8TZ7234D		POPPET SPRING - FM145
44/39	3530815		STEEL BALL - FM145
44/39	3727205		STEEL BALL - FM146
45	D50-31A	E5TZ7231A	SHIFT FORK 5-REV.
46	E8TZ7243G		SHIFT CONTROL SHAFT - 1986-89 BRONCO II AND RANGER - E87A-AEA - 1990 BRONCO II AND 1990-92 RANGER 4X4

FM145 / FM146 / FM132 STYLE (cont.)

ILL #	MIDWEST #	REF #	REPLACEMENT PART DESCRIPTION
46	F0TZ7243A		SHIFT CONTROL SHAFT - 1990 BRONCO II, 1990-91 RANGER, 2WD
47	E5TZ7243B		SHIFT CONTROL SHAFT - 1986-89 BRONCO II AND RANGER - E57A-KC, E67A-FB, E67A-FA
48	E5TZ7243A		SHIFT CONTROL SHAFT - 1988-89 BRONCO II AND RANGER - E57A-KB
53	E5TZ7034B		VENT FM145
53	E8TZ7034A		VENT FM146
54			
55	E5TZ7219A		SPRING
56	E5TZ70362A		BUSHING
58/64	E5TZ7032A		PLUG - SHIFT PLUG
59/63	E5TZ7B192A		SPRING - NEUTRAL RETURN
60	E5TZ7L003A		PLUNGER - NEUTRAL RETURN
61/65	E5TZ7B096A		PIN - SHIFT CONTROL LOCK (2 REQ.)
62	E5TZ7K132A		PLUNGER - SHIFT INTERLOCK
67	E5TZ7230A		SHIFT FORK 1-2, 1986-87 BRONCO II, 1988-92 RANGER - E67A-FB
67	E8TZ7230C		SHIFT FORK 1-2, 1988-92 - E87A-AEA
68/40	99222-0525		PIN
69	E5TZ7240A		SHIFT RAIL 1-2, 1986-87 BRONCO II, 1988-92 RANGER - E67A-FB
69	E8TZ7240D		SHIFT RAIL 1-2 FM146
70	E5TZ7241A		SHIFT RAIL 3-4 FM145
70	E8TZ7241C		SHIFT RAIL 3-4 FM146
71	D50-89A	E5TZ7289A	SHIFT FORK 3-4, 1986-92 - ALL
74	N801825-5100		NUT - REV. IDLER SHAFT
75	E5TZ7N037A		WASHER - NEW IDLER
76	E5TZ7141A		REV. IDLER GEAR - 17T
77	E5TZ7E139A		NEEDLE BEARING - REV. IDLER (2 REQ.)
79	E5TZ7C210A		BOLT - REV. IDLER SHAFT
80	F0TZ7100B		1ST GEAR MAIN SHAFT - 35T - 42 SPL.
82	E5TZ7127A		BEARING - MAIN SHAFT REV. GEAR
83	E5TZ7173D		SLEEVE - REV. GEAR BEARING (EXC. BELOW)
83	E5TZ7173A		SLEEVE - REV. GEAR BEARING - E57A-KB
84	E5TZ7142C		REV. GEAR M/S FM145, 34T - 36 SPL.
84	E8TZ7142D		REV. GEAR M/S FM146
85	MIT-14A		REV. RING
86	E5TZ7109C		SYNCHRO SPRING 1-2 (2 REQ.)
90	MIT-15	E8TZ7124G	SYNCHRO ASSY 5-REV., 36T - 29 SPL.
91	E5TZ7A044A		SYNCHRO KEY 5-REV. - FM146 (3 REQ.)
91	E5TZ7A044B		SYNCHRO KEY 5-REV. (3 REQ.)
92	MIT-14A	E5TZ7107A	SYNCHRO RING 5-REV. - FM145 - 5-REV. 36T - 1/2" KEY WIDTH
92	MIT-14H	E8TZ7107H	SYNCHRO RING REVERSE - FM146
93	E5TZ7071A		SPACER - NEEDLE BEARING
94	MW990006	E5TZ7121A	NEEDLE BEARING - M/S 5TH (REPAIR BRG KIT w/ SLEEVE)
95	MIT-5	F2TZ7C391A	5TH GEAR SET - UPDATED (INCLUDE #132)
96	E5TZ7173C		SLEEVE - M/S 5TH BEARING
97	E5TZ7119A		SPACER - M/S 5TH BEARING
98	206L	E5TZ7R205A	BEARING - REAR MAIN SHAFT
99	D50-148	E5TZ7045A	MAIN SHAFT NUT
100	E5TZ7061B		MAIN SHAFT - FM145 - 17-7/8" O.A., 25 SPL.
100	E8TZ7061G		MAIN SHAFT - FM146 - 2WD - 20.5" O.A., 25 SPL.
100	F0TZ7061C		MAIN SHAFT - FM146 - 4WD - 1990-92
101	E5TZ7133A		NEEDLE BEARING - 2ND GEAR
102	E5TZ7102A		2ND GEAR FM145 - 29T
102	E8TZ7102C		2ND GEAR FM146 - 30T
103/111	MIT-14B	E5TZ7107B	SYNCHRO RING 2ND GEAR - 42T - 1/2" KEY WIDTH
103/111	MIT-14C	E5TZ7107C	SYNCHRO RING 1ST GEAR - 42T - 15/16" KEY WIDTH
105/108	E5TZ7109C		SYNCHRO SPRING 1-2 - FM145
105/108	E8TZ7109C		SYNCHRO SPRING 1-2 - FM146
109	E5TZ7124A		SYNCHRO ASSY 1-2, 42T - 40 SPL.
110	E5TZ7A044C		SYNCHRO KEY 1-2 FM145 (3 REQ.)
110	E8TZ7A044B		SYNCHRO KEY 1-2 FM146 (3 REQ.)

FM145 / FM146 / FM132 STYLE (cont.)

ILL #	MIDWEST #	REF #	REPLACEMENT PART DESCRIPTION
111			SEE ITEM #103
112	E5TZ7133A		NEEDLE BEARING - 1ST GEAR
113	E5TZ7173B		SLEEVE - 1ST GEAR BEARING
114	MIT-11	E5TZ7101A	3RD GEAR FM145 - 24T
114	E8TZ7101C		3RD GEAR FM146 - L26-536
115	E5TZ7121A		NEEDLE BEARING - 3RD GEAR FM145
115	E8TZ7121C		NEEDLE BEARING - 3RD GEAR FM146
116			SEE ITEM #123
117/120	E5TZ7109A		SYNCHRO SPRING 3-4 (2 REQ.)
121	E5TZ7A044A		SYNCHRO KEY 3-4 (3 REQ.)
122	E5TZ7124B		SYNCHRO ASSY 3-4, 36T - 32 SPL.
123/116	MIT-14A	E5TZ7107A	SYNCHRO RING 3-4
124	E5TZ7N252A		SNAP RING - 2.15mm THICK, SELECTIVE
125	KMJ20X28X19-8	E8TZ7120D	BEARING - INPUT POCKET
126	MIT-16D	E8TZ7017D	INPUT - FM146 - 20T
126	MITF-16F	E5TZ7017A	INPUT - FM145 - 19T
127	TMSCO788NRCS40	E5TZ7025A	BEARING - INPUT SHAFT
128	E5TZ7029A		SNAP RING - .84mm THICK
129	E5TZ7030A		SNAP RING
130	E5TZ7N170A	D50-156	NUT - COUNTERSHAFT REAR
131	63122XN	35TZ7D283A	REAR CLUSTER BEARING
132	MIT-5	F2TZ7C391A	5TH GEAR SET - UPDATED (INCLUDES #95)
133	E5TZ7N040A		REVERSE GEAR - COUNTERSHAFT
134	E9TZ7115B		SPACER - COUNTERSHAFT REVERSE
135	E5TZ7N112A		SHIM - 1.84mm THICK
136	4T-30205	E5TZ7065A	BEARING - COUNTERSHAFT CENTER
137	MIT-8	E5TZ7113A	CLUSTER GEAR 28-26-20-13 FM145
137	MIT-8A	E8TZ7113C	CLUSTER GEAR 28-24-19-13 FM146
138	4T-30205	E5TZ7065A	BEARING - COUNTERSHAFT FRONT
139	E5TZ7052A		SPACER - COUNTERSHAFT FRONT

KITS

T50R	→	BEARING, SEAL & GASKET KIT - FM145 / FM146
T50RMK	→	BEARING, SEAL & GASKET MASTER KIT WITH RINGS - FM145
T50RAMK	→	BEARING, SEAL & GASKET MASTER KIT - FM146
T50RB	→	BEARING, SEAL & GASKET KIT - FM132
T50RBMK	→	BEARING, SEAL & GASKET MASTER KIT W/ RINGS - FM132
MIT-55	→	GASKET KIT
RK50	→	SYNCHRO RING KIT FM145
RK50A	→	SYNCHRO RING KIT FM146
K50	→	GASKET & SEAL KIT

UNMATCHED

durability • power • performance

“...We had run 3 UROC Pro National events, featuring the most grueling obstacles in rock crawling history, without a drop of fluid in the diffs...When we found the problem we only had time to add oil. They continued to work so well that we completed the rest of the 2005 UROC Pro National Series and Super Crawl IV in Las Vegas! **Motive Gears have got to be THE TOUGHEST GEARS available, I wouldn't run anything else!**”

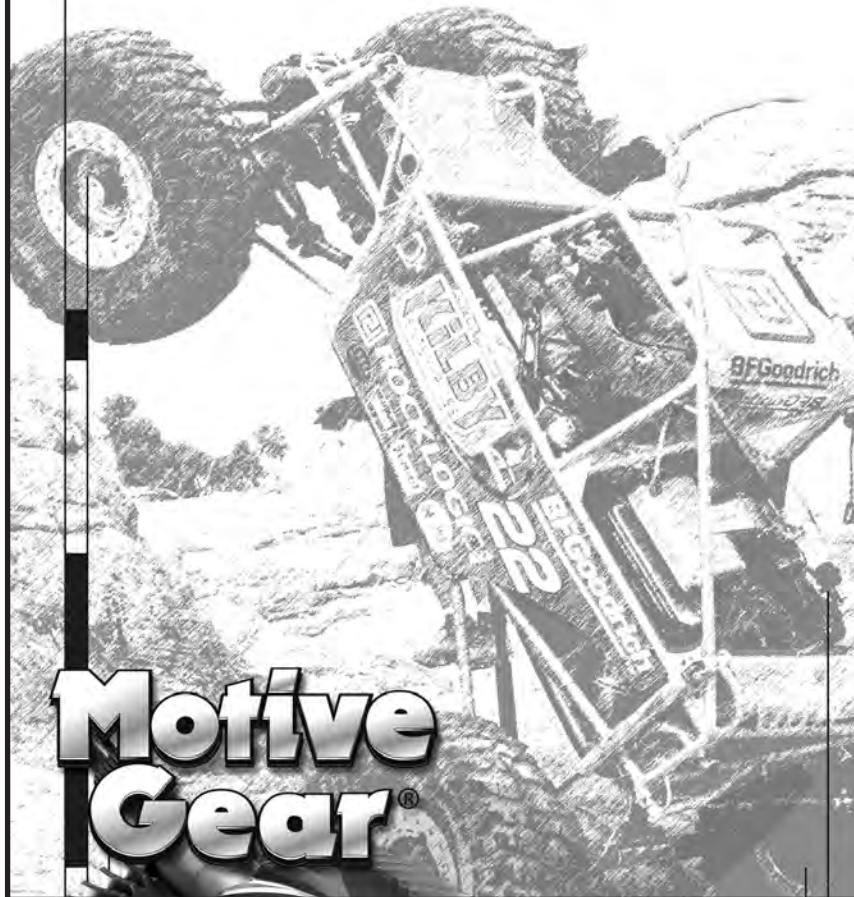

**Motive
Gear®**

M5R1 STYLE

FORD® AEROSTAR 1985-95, EXPLORER 1991 & UP, BRONCO II 1988-90, RANGER 1988 & UP, EXPLORER SPORT, EXPLORER SPORT TRAC 2001-02

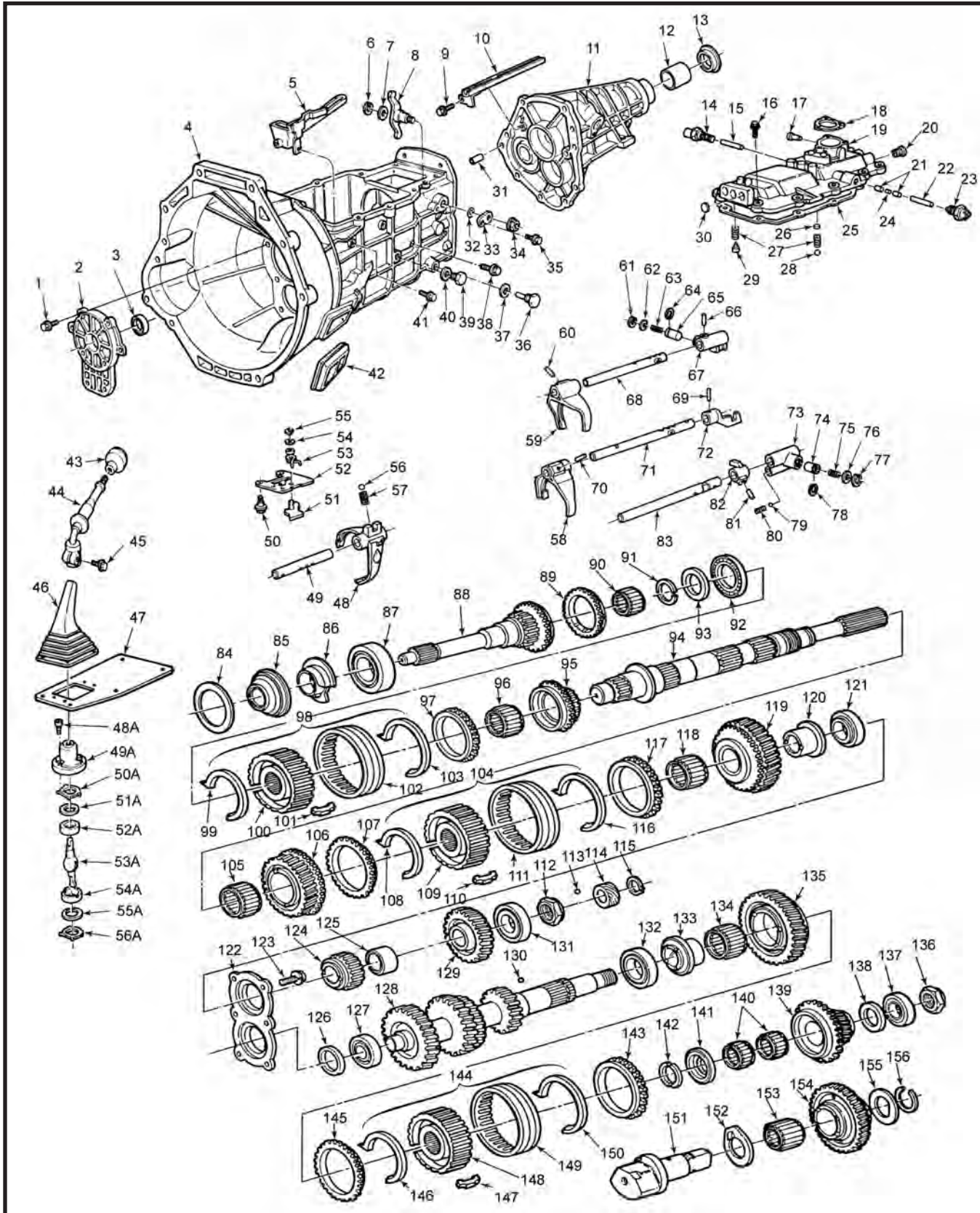

M5R1 STYLE (cont.)

ILL #	MIDWEST #	REF #	REPLACEMENT PART DESCRIPTION
1	99796-0825		BOLT - FRONT RETAINER
2	M5R1-6	E8TZ7050A	RETAINER, FRONT BEARING
3	1990		SEAL - INPUT
4	VARIOUS APPLICATIONS		MAIN CASE - CALL - APPLICATION
5	M5R1-63	E8TZ7A174C	OIL TROUGH - FRONT
6	99573-1600		RETAINING RING
7	E8TZ70448A		WASHER, LEVER
8	F1TZ7243A		LEVER ASSY - 5-REV.
9			BOLT - REAR OIL TROUGH
10	E8TZ74174C		OIL TROUGH - REAR
11	VARIOUS APPLICATIONS		EXTENSION HOUSING - CALL - APPLICATION
12	M5R1-62	E8TZ7A039A	BUSHING - REAR OUTPUT
13	2245	E8TZ7052C	SEAL - OUTPUT 2WD
13	1981	E8TZ7052D	SEAL - OUTPUT 4WD
14	F4TB15520AA		SWITCH - REVERSE LIGHT
15	E3TZ7392A		PIN - REVERSE LIGHT SWITCH
16	99796-0825		BOLT - TOP COVER
17	MP50-P1		PIN - SHIFT LEVER
18	E8TZ7207B		GASKET - SHIFT CAP
19	CALL - APPLICATION		COVER - SHIFT TOP
20	555-108		WELCH PLUG - SHIFT RAIL - REAR
21	E8BZ7C316B		PIN - INTERLOCK (2 REQ.)
22	CALL - APPLICATION		PIN - NEUTRAL SWITCH - CALL - APPLICATION
23	E8TZ79072A		SWITCH - SHIFT LEVER POSITION
24	E8TZ7235A		PIN - INTERLOCK
25	M5R1-55		GASKET - TOP COVER
27	CALL - APPLICATION		SPRING - DETENT
28/56/79	99611-2500		BALL - DETENT
29	E8TZ7D210A		SEAT - DETENT SPRING
30	219-1135		WELCH PLUG - TOP COVER RAIL HOLE
31	N/A		DOWEL - CASE ALIGNMENT
32	99541-02001		O-RING, SEAL - SHIFT LEVER
33	E8TZ7C277A		LOCK PLATE - SHIFT LEVER
34	E8TZ7N428A		NUT - SHIFT LEVER
35	99796-0612		BOLT - SWITCH RETAINING
36	E8TZ7A010A		PLUG - DRAIN
37/40	99564-1800		GASKET - PLUG (2 REQ.)
39	E8TZ7A010B		PLUG - FILL
38	E8TZ7214A		BOLT - REVERSE IDLER
41	99796-0620		BOLT
42	E8TZ7564A		PLUG - CLUTCH INSPECTION HOLE
46	CALL - APPLICATION		VEHICLE SPECIFIC
47	N/A		N/A - CONTACT VEHICLE MANUFACTURER
48A	M5R1-111		BOLT - SHIFT BOOT
48	F1TZ7289B		SHIFT FORK, 5-REV. - UPDATED
49A	E8TZ7277A		RETAINER - BOOT
49	F1TZ7242A		SHIFT RAIL, 5-REV. LOWER
50	E9S27A443A		BOLT, DETENT PLATE
51			REVERSE GATE
51A	M5R1-109		SHIFTER STUB SPACER
52	E8TZ7K201C		PLATE - SHIFT INTERLOCK
52A	M5R-28A		RUBBER SHIFTER SEAT
53A	M5R1-105		SHIFTER STUB
54	E8TZ7E201A		WASHER, REVERSE GATE
54A	M5R-28A		RUBBER SHIFTER SEAT
55	99576-0800		LOCK RING, REVERSE GATE
50A/56A	M5R1-109		SHIFTER STUB SPACER
57/26			
58	M5R1-23A	E8TZ7231A	SHIFT FORK, 3-4
59	M5R1-23	E8TZ7230A	SHIFT FORK, 1-2
60/66/69/	99222-0525		ROLL PIN, FORK & SHIFT LUGS
70/81			
61/77	99574-1300		LOCK RING
63/75/80	CALL - APPLICATION		SPRING, SHIFT DETENT - CALL - LENGTH
64/78	E8TZ7064A		LOCK RING, SHIFT DETENT
65/74	E8TZ7247B		PLUNGER, SHIFT DETENT, 5-REV.
67	E8TZ7279C		RAIL END 3-4
68	E8TZ7240A		SHIFT RAIL 1-2
71	E8TZ7241A		SHIFT RAIL 3-4

M5R1 STYLE (cont.)

ILL #	MIDWEST #	REF #	REPLACEMENT PART DESCRIPTION
72	E8TZ7232B		GATE, SHIFT RAIL 3-4
73	E8TZ7411D		GATE, ASSY, SHIFT RAIL 5-REV.
76	E8TZ7L015A		WASHER, SHIFT DETENT
82	E8TZ7K003A		GATE, SHIFT RAIL 5-REV.
83	E8TZ7334A		SHIFT RAIL 5-REV.
84	M5R1-SK		SHIM KIT - INPUT
85	3541		BAFFLE SEAL - INPUT
86	M5R1-46A	E8TZ7046A	OIL RING - INPUT SLINGER
87	30207/80	E8TZ7025A	BEARING, INPUT
88	M5R1-16	F0TZ7017B	INPUT SHAFT - 2.3/2.9/3.0 - 23T - MATES - M5R1-8
88	M5R1-16A	F0TZ7017A	INPUT SHAFT - 4.0L - 23T - MATES - M5R1-8A
89	M5R2-14E	F1TZ7107E	SYNCHRO RING - 4TH GEAR
89	1L2Z7107AA		4TH GEAR SYNCHRO RING - USED WITH 3 PC. DESIGN
90	K25X33X24	F0TZ7120A	BEARING, INPUT POCKET NEEDLE
91	E8TZ7030A		SNAP RING
92	E8TZ7C096A		BEARING, INPUT THRUST
93	E8TZ7N112B		SPACER - INPUT REAR TO 1992
93	E8TZ7N112A		SPACER - INPUT REAR 1993-ON
94	M5R1-2	E8TZ7061B	MAIN SHAFT, 4WD
94	M5R1-2A		MAIN SHAFT, 2WD
94	1L5Z7061BA		MAIN SHAFT, 2WD - 1994-ON
95	M5R1-11	E8TZ7101A	3RD GEAR, MAIN SHAFT - EXC. 4.0L - 29T
95	M5R1-11A	F0TZ7101A	3RD GEAR, MAIN SHAFT - 4.0L - 27T
96	E8TZ7127A		NEEDLE BEARING, 3RD GEAR M/S
97	M5R2-14E	F1TZ7107E	SYNCHRO RING - 3RD GEAR
97	XL3Z710AA		3RD GEAR SYNCHRO RING - (FIBER LINED)
98	M5R1-2.5	F2TZ7124C	SYNCHRO HUB & SLEEVE ONLY, (3-4)
98	M5R1-2.5A		SYNCHRO ASSY, (3-4) TO - COMPLETE
99/103	E8TZ7109B		SPRING, SYNCHRO - CAN USE M5R1-K3
100	N.S.S.		SEE #98
101	1L5Z7A044BA		KEY, SYNCHRO - CAN USE M5R1-K3
104	F1TZ7124A		SYNCHRO ASSY 1-2
105	E8TZ7133A		NEEDLE BEARING, 2ND GEAR M/S
106	M5R1-21	E8TZ7102A	2ND GEAR, M/S - EXC. 4.0L - 32T - (1) I.D. GROOVE
106	M5R1-21A	F0TZ7102A	2ND GEAR, M/S - 4.0L - 31T - NO I.D. GROOVE
107	M5R2-14E	F1TZ7107E	SYNCHRO RING - 2ND GEAR
107	XL3Z7107BA		1-2 SYNCHRO RINGS - 3 PC. DESIGN, 2002-ON (FIBER LINED)
108/116	E8TZ7109B		SPRING, SYNCHRO - CAN USE M5R1-K3
109	N.S.S.		SEE #104
110	1L5Z7A044BA		KEY, SYNCHRO
111	N.S.S.		
112	M5R1-149	E8TZ7B364A	NUT, M/S REAR
113/130	99611-2000		BALL - SPEEDO
114	M5R1-169G		GEAR - SPEEDO DRIVE - GREEN
114	M5R1-169W		GEAR - SPEEDO DRIVE - WHITE
115	E8TZ7059A		SNAP RING
117	M5R2-14E	F1TZ7107E	SYNCHRO RING - 1ST GEAR
117	XL3Z7107BA		1-2 SYNCHRO RINGS - 3 PC. DESIGN, 2002-ON (FIBER LINED)
118	E8TZ7133A		NEEDLE BEARING - 1ST GEAR M/S
119	E8TZ7100D		1ST GEAR, MAIN SHAFT - EXC. 4.0L
119	F3TZ7100A		1ST GEAR, MAIN SHAFT - 4.0L
120	E8TZ7173C		SLEEVE, 1ST GEAR NEEDLE BEARING TO 1992
120	E8TZ7173A		SLEEVE, 1ST GEAR NEEDLE BEARING 1993-ON
121	30207JR	E8TZ7118A	BEARING, M/S CENTER
122	M5R1-144	E8TZ7085A	RETAINER PLATE, M/S AND C/S REAR BEARINGS
123	99784-0820B		BOLT - RETAINER PLATE
124	M5R1-18A	F0TZ7112A	5TH GEAR, M/S - 4.0L - UPDATED
124	E8TZ7112A		5TH GEAR, M/S - EXC. 4.0L
125	E8TZ7072A		SPACER - M/S - 5-REV.
128	M5R1-8	E8TZ7113D	CLUSTER GEAR, ALL - 2.3/2.9/3.0 - 38-32-24-16
128	M5R1-8A	F0TZ7113A	CLUSTER GEAR - 4.0 - 38-34-25-17
129	M5R1-36		REVERSE GEAR, M/S
129	M5R1-36A		REVERSE GEAR, M/S - UPDATED (30T)
131	6207/33A1C3		BEARING, M/S REAR
132	RUS206/NJ206	E8TZ7121A	BEARING, C/S CENTER
133	E8TZ7173D		SLEEVE, C/S 5TH RACE
134	E8TZ7R130A		NEEDLE BEARING, C/S 5TH GEAR
135	M5R1-19A	F1TZ7158B	5TH GEAR, C/S - 4.0L - UPDATED
135	F1TZ7158A		5TH GEAR, C/S - 2.3/2.9/3.0 - UPDATED

M5R1 STYLE (cont.)

ILL #	MIDWEST #	REF #	REPLACEMENT PART DESCRIPTION
136	M5R1-167	E8TZ7N170A	NUT, C/S REAR
138	E8TZ7L324B		THRUST WASHER - C/S REV.
139	M5R1-36		REVERSE GEAR, C/S - NON-UPDATED
139	M5R1-36A	F1TZ7N040C	REVERSE GEAR, C/S - UPDATED
140	K24X28X16.5	E8TZ7N270A	NEEDLE BEARING - C/S REV.
141	E8TZ70340D		THRUST WASHER - C/S REV.
142	E8TZ7R482A		THRUST WASHER - SPLIT
143	M5R1-14	E8TZ7107C	SYNCHRO RING - REV. - NON-UPDATED 36T
143	M5R1-14C	F1TZ7107C	SYNCHRO RING - REV. - UPDATED 30T
143	XL3Z7107CA		REVERSE GEAR SYNCHRO RING - (FIBER LINED)
144	M5R1-40		SYNCHRO ASSY 5-REV. - UPDATED, NLA: USE M5R1-15A
145	M5R1-14B	F1TZ7107B	SYNCHRO RING - 5TH GEAR - UPDATED 30T
146/150	E8TZ7109B		SYNCHRO SPRING - 5-REV. - CAN USE M5R1-K3
147	1L5Z7A044BA		SYNCHRO KEY - 5-REV. - NON-UPDATED
148	N.S.S.		
149	M5R1-15		SYNCHRO SLEEVE, 5-REV. NON-UPDATED - 36T
149	M5R1-15A		SYNCHRO SLEEVE, 5-REV. UPDATED - 30T
151	1L5Z7140AA		SHAFT, REV. IDLER
152	E8TZ7N037A		THRUST WASHER, REV. IDLER FRONT
153	38TZ7E139A		NEEDLE BEARING, REV. IDLER
154	1L5Z7141AA		REVERSE IDLER GEAR - 2.3/2.9/3.0
154	1L5Z7141BA		REVERSE IDLER GEAR - 4.0L
155	E8TZ7N037B		THRUST WASHER, REV. IDLER REAR
156	E8TZ7156A		SNAP RING, REV. IDLER RETAINING
N.I.	MAZ-14A		SYNCHRO RING - 5TH GEAR - NON-UPDATED 36T

KITS

T247R	→	BEARING, GASKET & SEAL KIT
T247RMK	→	MASTER BEARING KIT - SYNCHRO RINGS, NON-UPDATED
T247RAMK	→	MASTER BEARING KIT - SYNCHRO RINGS, UPDATED
K247	→	GASKET & SEAL KIT
M5R1-K3	→	SYNCHRO KEY & SPRING KIT 1-2, 3-4
M5R1-SK	→	INPUT SHAFT SHIM KIT
M5R1-REVKIT	→	REVERSE GEAR KIT - NON-UPDATED (INCLUDES REV. GEAR, SLIDER, SYNCHRO RING)
RKL-M5R1	→	REVERSE GEAR KIT - UPDATED (INCLUDES REVERSE GEAR, SLIDER, SYNCHRO RING)
RK247	→	SYNCHRO RING KIT - NON-UPDATED
RK247A	→	SYNCHRO RING KIT - UPDATED
FK-M5R1	→	FRONT REPAIR KIT
FKT-M5R1	→	FK-M5R1 - PLUS TOP COVER SHIFT PINS, RAIL PLUGS, SHIFTER SEATS
F0TZ7C391D	→	5-REV. SYNCHRO UPDATE KIT (GENUINE FORD PARTS) - 4.0 ENGINE
F0TZ7C391C	→	5-REV. SYNCHRO UPDATE KIT (GENUINE FORD PARTS) - 2.9/3.0 ENGINE

M5R2 STYLE

FORD® FULL SIZE PICK-UP 1988 & UP
BRONCO 1988-92, ECONOLINE 1988-89

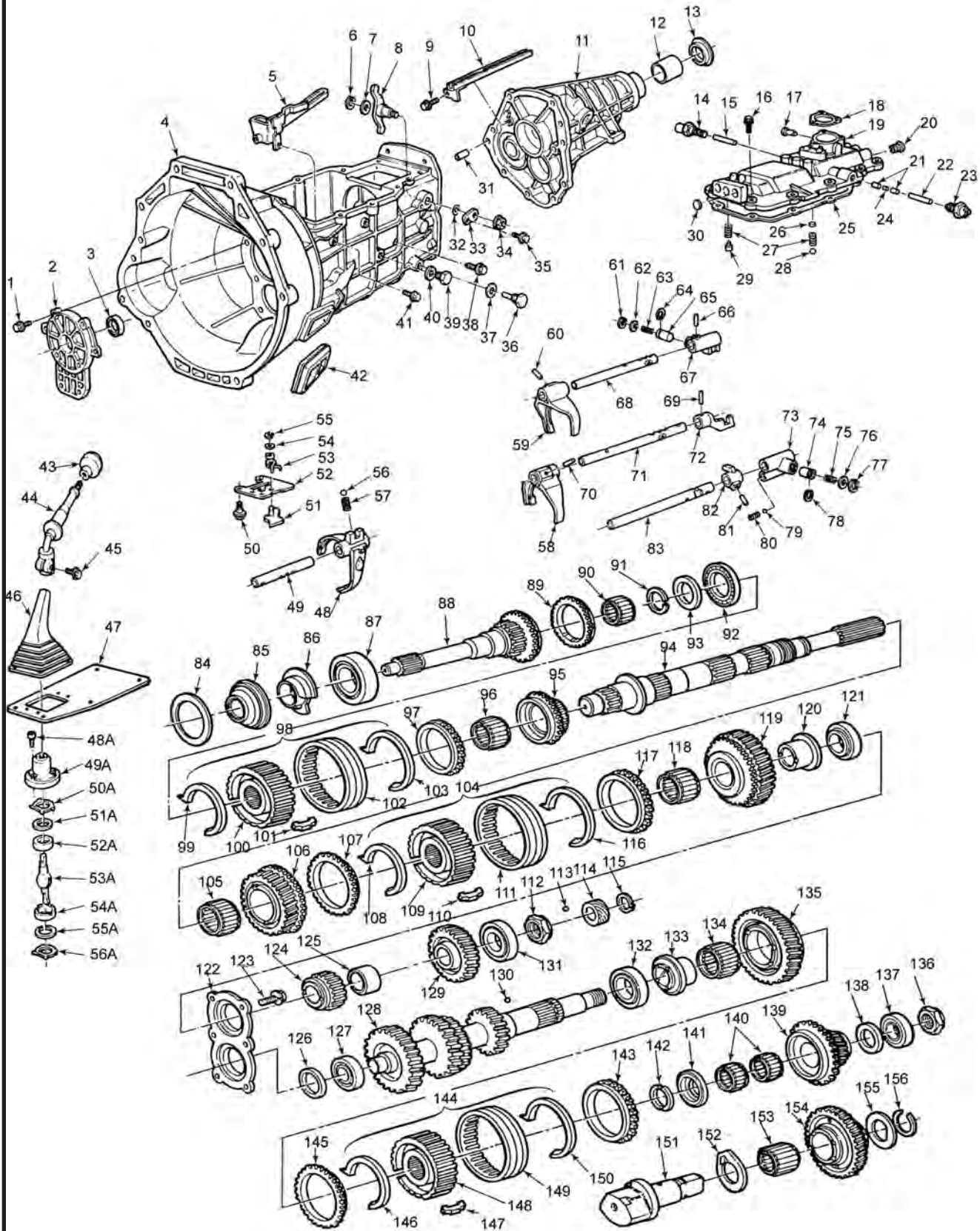

M5R2 STYLE (cont.)

ILL #	MIDWEST #	REF #	REPLACEMENT PART DESCRIPTION
1	99796-0825		BOLT - FRONT RETAINER
2	E8TZ7050B		RETAINER - FRONT BEARING
4	CALL		MAIN CASE ASSY - CALL - APPLICATION
3	223012		SEAL - FRONT INPUT
5	M5R2-63	E8TZ7A174D	OIL TROUGH - FRONT
6	99573-1600		RETAINING RING - REVERSE PIVOT ARM
7	E8TZ70448A		WASHER - SHIFT LEVER
8	F1TZ7243B		LEVER ASSY - REVERSE SHIFT
9			BOLT - REAR OIL TROUGH
10	E8TZ7A174B		OIL TROUGH - REAR
11	VARIOUS APPLICATIONS		EXTENSION HOUSING - CALL - APPLICATION
12	M5R1-62	E8TZ7A039A	BUSHING - REAR EXTENSION 2WD
13	2245	E8TZ7052C	SEAL - OUTPUT 2WD
13	E2132	MD703743	SEAL - OUTPUT 4WD
14	E8TZ7G072A		SWITCH - NEUTRAL SAFETY
15			PIN - NEUTRAL SAFETY SWITCH
16	99796-0825		BOLT - TOP COVER TO CASE
17	MP50-P1		SHIFT LEVER ALIGNMENT PIN
18	E8TZ7207B		GASKET - SHIFT LEVER
19	VARIOUS APPLICATIONS		SHIFT COVER ASSY - CALL - APPLICATION
20	555-108		PLUG - TOP COVER/SHIFT RAIL
21	E8BZ7C316B		PIN - SHIFT INTERLOCK
22	E8TZ7392A		PIN - REVERSE LIGHT SWITCH
23			SWITCH - REVERSE LIGHT
24	E8TZ7235A		PIN - SHIFT INTERLOCK
25	M5R2-55		GASKET - TOP COVER TO CASE
26			
27/57	D2TZ7234C		SPRING - SHIFT LOCK DETENT
28/56/79	99611-2500		BALL - SHIFT LOCK DETENT
29	E8TZ7D210A		SEAT - SHIFT DETENT SPRING
30	219-1135		PLUG - TOP COVER-FRONT
31			DOWEL - CASE ALIGNMENT
32	99541-02001		O-RING - SHIFT LEVER SHAFT
33	E8TZ7C277A		LOCK PLATE - SHIFT LEVER
34	E8TZ7N428A		NUT - SHIFT LEVER SHAFT
35	99796-0612		BOLT - SHIFT LEVER RETAINER
36/39	E8TZ7A010C		PLUG - DRAIN/FILL
37/40	99564-1800		GASKET - DRAIN/FILL PLUG
38	IL5Z7214AA		BOLT - REVERSE IDLER RETAINER
41	99796-0620		BOLT - FRONT OIL TROUGH
42	IL5Z7564AA		COVER - CLUTCH INSPECTION
43			SHIFT KNOB
44	E8TZ7210R		SHIFT LEVER
45			BOLT - SHIFT LEVER
46			VEHICLE SPECIFIC - REF ONLY
47			VEHICLE SPECIFIC - REF ONLY
48	F1TZ7289C		SHIFT FORK 5-REV.
48A	M5R1-111	E8TZ7A443A	BOLT - SHIFT STUB 20mm LONG (3 REQ.)
49	F1TZ7142B		SHIFT RAIL, 5-REV. SHIFT
49A	E8TZ7277A		SHIFT STUB RETAINER - BOOT
50	E8TZ7A443A		BOLT - 20mm LONG
50	E95Z7A443A		BOLT - 12mm LONG
51A	E8TZ7E018A		SHIM - SHIFT STUB
52	E8TZ7K201D		PLATE - SHIFT INTERLOCK
52A	M5R-28A		SHIFTER SEAT - RUBBER
53A	M5R2-105		SHIFTER STUB
54A	M5R-28A		SHIFTER SEAT - RUBBER
55	99576-0800		BOLT - SHIFT INTERLOCK PLATE
55A	E8TZ7E018A		SHIM - SHIFT STUB
56A	E8TZ7Z120A		WAVE WASHER - SHIFT STUB
N.I.	E8TZ72120A		WAVE WASHER - SHIFT STUB
58	M5R2-23D	F75Z7231AA	3-4 FORK, 1997-ON ALUMINUM
58	M5R2-23A	F1TZ7231A	SHIFT FORK 3-4, 1988-95
58	M5R2-23AB	F65Z7231AA	SHIFT FORK 3-4, 1996-ON
59	M5R2-23C	F75Z7230BA	1-2 FORK, 97-ON ALUMINUM
59	M5R2-23	F1TZ7230A	SHIFT FORK 1-2, 1988-95
59	M5R2-23AA	F65Z7230AA	SHIFT FORK 1-2, 1996-ON
60/66/69	99222-0525		ROLL PIN - SHIFT FORK TO RAIL

M5R2 STYLE (cont.)

ILL #	MIDWEST #	REF #	REPLACEMENT PART DESCRIPTION
61/77	99574-1700		LOCK RING - SHIFT DETENT
62/76	FOTZ7L015A		WASHER - 13mm O.D.
62/76	E8TZ7L015B		WASHER - 17mm O.D.
63/75/80	E8TZ7N120C		SPRING - DETENT 34mm LONG
63/75/80	E8TZ7N120F		SPRING - DETENT 26mm LONG
64/78	E8TZ7064A		LOCK RING - SHIFT PLUNGER
65/74	E8TZ7247A		PLUNGER - SHIFT DETENT
68	E8TZ7240B		SHIFT RAIL, 1-2 SHIFT
70/81	99222-0525		ROLL PIN - SHIFT FORK TO RAIL
71	F1TZ7241A		SHIFT RAIL, 3-4 SHIFT
82	E8TZ7K003D		SHIFT GATE, 5-REV. RAIL
83	E8TZ7334B		SHIFT RAIL, 5-REV. SHIFT
84	M5R2-SK		SHIM KIT - INPUT
85	3421	E8TZ7040B	BAFFLE SEAL - INPUT
86	M5R2-46B	E8TZ7046B	OIL SLINGER - INPUT
87	NTFR37Z-2AG5U4	E8TZ7025B	BEARING - INPUT
88	M5R2-16	E8TZ7017E	INPUT SHAFT - 1988-95, 11" O.A., 24T
88	M5R2-16A	F65Z7017AA	INPUT SHAFT - 1996-ON, 11-3/8" O.A. - O.H.C. ENGINE
89	M5R2-14G	F1TZ7107G	SYNCHRO RING - 4TH GEAR
90	PK31X43X23.8X	E8TZ7120B	NEEDLE BEARING - INPUT POCKET
91	E8TZ7030A		LOCK RING - INPUT POCKET BEARING
92	E8TZ7C096B		THRUST BEARING - INPUT
93	E8TZ7N112B		SPACER - INPUT THRUST BEARING
94	M5R2-2	E8TZ7061D	MAIN SHAFT - 4X4, 1988-93
94	F65Z7061AA		MAIN SHAFT - 4X4, 1994-ON
94	E8TZ7061C		MAIN SHAFT - 2WD, 1988-97 - 21-3/4" O.A.
94	F2TZ7061E		MAIN SHAFT - 2WD, 1994-ON
95	M5R2-11	E8TZ7101B	3RD GEAR, M/S 30T
96	E8TZ7127B		NEEDLE BEARING - 3RD GEAR M/S
97	M5R2-14G	F1TZ7107G	SYNCHRO RING, 3RD GEAR
97	XL3Z7107AA		SYNCHRO RING, 3RD GEAR (FIBER LINED)
98	M5R2-2.5	F1TZ7124H	SYNCHRO HUB & SLEEVE 3-4
98	M5R2-2.5A	F1TZ7124M	SYNCHRO ASSY 3-4, COMPLETE WITH RINGS
98	M5R2-2.5B		3-4 SYNCHRO WITH KEYS & SPRINGS - 1996-ON
99/103	F1TZ7124CB		SPRING - SYNCHRO
100	N.S.S.		MUST PURCHASE ITEM #98
101	IL5Z7A044BA		SYNCHRO KEY
102	N.S.S.		MUST PURCHASE ITEM #98
104	F1TZ7124G		SYNCHRO ASSY 1-2, 1988-96
104	F75Z7124DD		SYNCHRO ASSY 1-2, 1997-2000
104	XL3Z7124AA		SYNCHRO ASSY 1-2, 2000-ON
105	IL5Z7133AA		NEEDLE BEARING - 2ND GEAR M/S
106	E8TZ7102D		2ND GEAR, M/S 1988-99 (35T)
106	XL3Z7102AA		2ND GEAR, M/S 2000-ON
107	M5R2-14G	F1TZ7107G	SYNCHRO RING, 2ND GEAR
108/116	F1TZ7124CB		SPRING - SYNCHRO
109	N.S.S.		MUST PURCHASE ITEM #104
110	IL5Z7A044BA		SYNCHRO KEY
111	N.S.S.		MUST PURCHASE ITEM #104
112	M5R2-149		NUT - MAIN SHAFT REAR
113/130	99611-2000		BALL - SPEEDO RETAINER
114	M5R1-169G	E8TZ17285A	GEAR - SPEEDO DRIVE - 6T - PURPLE
114	M5R1-169W	E8TZ17285B	GEAR - SPEEDO DRIVE - 7T
114	E8TZ17285C		GEAR - SPEEDO DRIVE - 8T
115	E8TZ7059A		SNAP RING - SPEEDO GEAR
117	M5R2-14G	F1TZ7107G	SYNCHRO RING, 1ST GEAR
118	IL5Z7133AA		NEEDLE BEARING - 1ST GEAR M/S
119	E8TZ7100E		1ST GEAR, M/S
120	E8TZ7173C		SLEEVE - 1ST GEAR NEEDLE BEARING
124	M5R2-18	E8TZ7112B	5TH GEAR, M/S 27T
125	E8TZ7072B		SPACER - MAIN SHAFT REVERSE
126	E8TZ7C434T		SPACER - C/S FRONT BEARING
127	05NJ0620VHCS43	E8TZ7065B	BEARING - C/S FRONT
128	M5R2-8	E8TZ7113B	CLUSTER GEAR - 37-31-24-15
129	E8TZ7142B		REV. GEAR, M/S
131	6208/37A1		BEARING - MAIN SHAFT REAR
132	NJK207C3	E8TZ7121B	BEARING - C/S CENTER
133	E8TZ7173D		SLEEVE - C/S 5TH GEAR

M5R2 STYLE (cont.)

ILL #	MIDWEST #	REF #	REPLACEMENT PART DESCRIPTION
134	E8TZ7R130A		NEEDLE BEARING, C/S 5TH GEAR
135	M5R2-19		5TH GEAR, C/S NON-UPDATED (42 SYNCHRO TEETH)
135	M5R2-19A	F1TZ7158C	5TH GEAR, C/S UPDATED
136	E8TZ7N170A		NUT, C/S REAR
137	6304N		BEARING, C/S REAR
138	E8TZ7L324B		THRUST WASHER, C/S REVERSE - REAR
139	M5R2-36		REV. GEAR, C/S - NON-UPDATED, 42 SYNCHRO TEETH
139	M5R2-36A	XL3Z7N040AA	REV. GEAR, C/S - UPDATED
140	K25X30X20S	E8TZ7N270B	NEEDLE BEARING, C/S REVERSE
141	E8TZ7C340D		THRUST WASHER, C/S REVERSE
142	E8TZ7R482A		THRUST WASHER, SPLIT
143	M5R2-14		SYNCHRO RING, REV. NON-UPDATED 42T
143	M5R2-14D	F1TZ7107D	SYNCHRO RING, REV. UPDATED 33T
143	XL3Z7107BA		SYNCHRO RING, REV. (FIBER LINED)
144	M5R2-40	F1TZ7124F	SYNCHRO ASSY, 5-REV. - UPDATED - NLA - USE M5R2-15A
145	M5R2-14A	F1TZ7107A	SYNCHRO RING, 5TH GEAR - UPDATED 33T
145	M5R2-14E	F1TZ7107E	SYNCHRO RING, 5TH GEAR - NON-UPDATED 42T
145	XL3Z7107FA		SYNCHRO RING, 5TH GEAR (FIBER LINED)
146/150	F1TZ7124CB		SYNCHRO SPRING, 5-REV.
147	F1TZ7A044A		SYNCHRO KEY, 5-REV.
148	N.S.S.		SYNCHRO HUB - MUST PURCHASE ITEM #144
149	M5R2-15	E8TZ7124N	SLEEVE, 5-REV. SYNCHRO - NON-UPDATED 42T
149	M5R2-15A		SLEEVE, 5-REV. SYNCHRO - UPDATED 33T
151	E8TZ7140B		SHAFT, REVERSE IDLER
152	E8TZ7N037C		THRUST WASHER, REVERSE IDLER - FRONT
153	E8TZ7E139B		NEEDLE BEARING, REVERSE IDLER
154	M5R2-10	XL3Z7141AA	REVERSE IDLER GEAR
155	E8TZ7N037D		THRUST WASHER, REVERSE IDLER - REAR
156	E8TZ7156B		SNAP RING, REVERSE IDLER

KITS

T248R	➔	BEARING, GASKET & SEAL KIT
T248RMK	➔	BEARING KIT - SYNCHRO RINGS - NON-UPDATED 5-REV.
T248RAMK	➔	BEARING KIT - SYNCHRO RINGS - UPDATED 5-REV.
K248	➔	GASKET & SEAL KIT
RK248	➔	SYNCHRO RING KIT - NON-UPDATED 5-REV.
RK248A	➔	SYNCHRO RING KIT - UPDATED 5-REV.
M5R2-K3	➔	SYNCHRO KEY & SPRING KIT 1-2 & 3-4
M5R2-REVKIT	➔	REVERSE GEAR KIT (INCLUDES REVERSE GEAR, SLIDER, RING) NON-UPDATED
RKL-M5R2	➔	REVERSE GEAR KIT (INCLUDES REVERSE GEAR, SLIDER, RING) UPDATED
FK-M5R2	➔	FRONT REPAIR KIT
FKT-M5R2	➔	SAME AS ABOVE - TOP COVER SHIFTER BUSHINGS AND WELCH PLUGS
F0TZ7C391E	➔	5-REV. UPDATED KIT (GENUINE FORD® PARTS)
M5R2-SK	➔	INPUT SHIM
NK248	➔	NEEDLE BEARING KIT

ZF® S5-42 / S5-47 STYLE

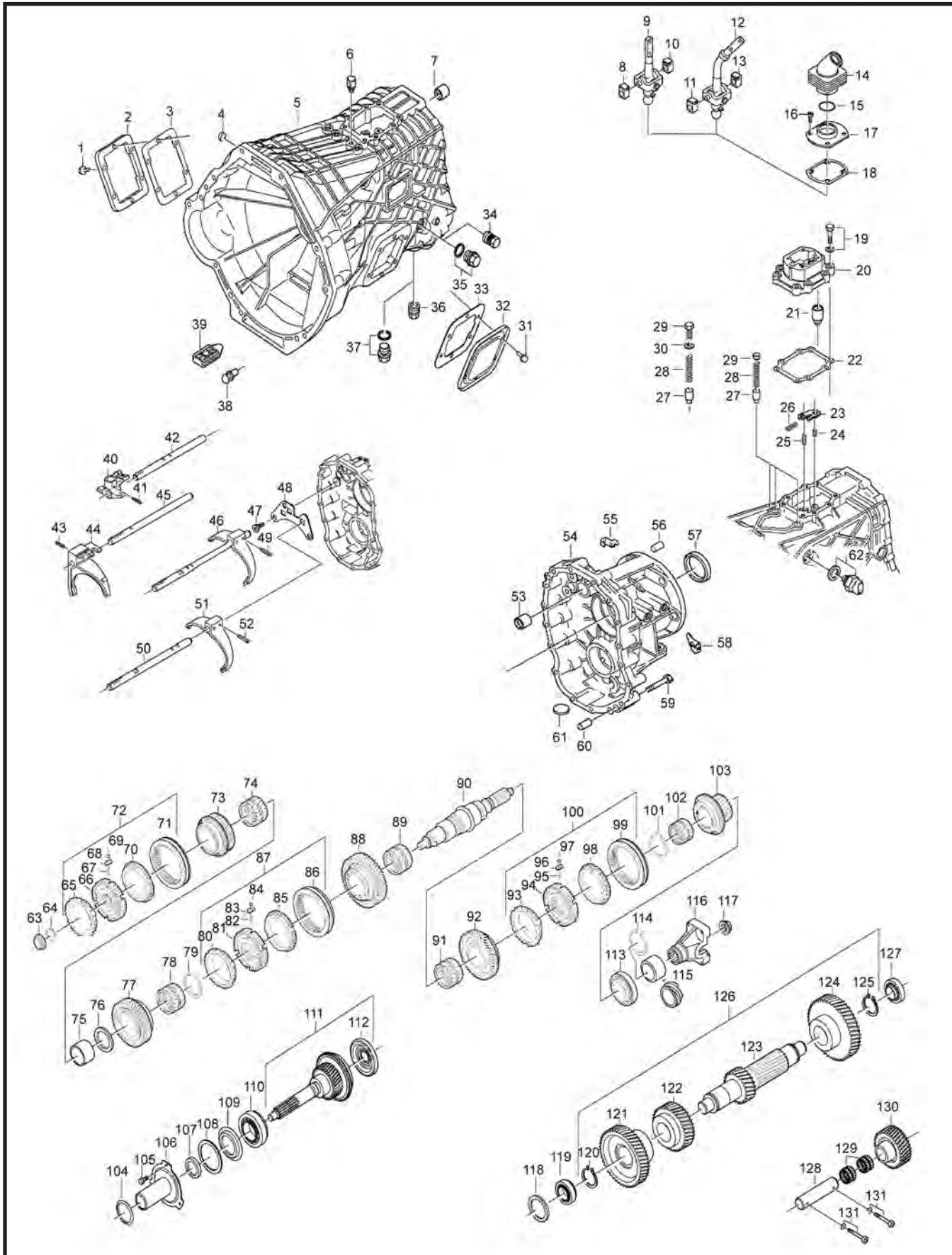

ZF® S5-42 / S5-47 STYLE (cont.)

ILL #	MIDWEST #	REF #	REPLACEMENT PART DESCRIPTION
1	0736617043		HEXAGON SCREW
2	1304301035		COVER
3	1290301140		GASKET
4	0630361077		SEALING CAP
5	1307201005		MAIN HOUSING - S5-42 GAS (4.9/5.8)
	1307201076		MAIN HOUSING - S5-42 DIESEL
	1307201080		MAIN HOUSING - S5-42 GAS (7.5)
	1317201014		MAIN HOUSING - S5-47 GAS (4.9/5.8)
	1317201015		MAIN HOUSING - S5-47 DIESEL
	1317201016		MAIN HOUSING - S5-47 GAS (7.5)
6	0501202797		BREATHER
7	0750115238		BALL SLEEVE
8/10/11/13	1307306154		GUIDE PIECE
9/12	1307218006		GEAR SHIFT LEVER - S5-42
	1307218007		GEAR SHIFT LEVER - S5-42 (WITH TAG# 064 OR 103)
	1317218002		GEAR SHIFT LEVER - S5-47
14	1307306236		INNER TRANS BOOT - S5-42
	1317306014		INNER TRANS BOOT - S5-47
15	0730505093		SNAP RING
16	0636101679		CAP SCREW M6X16 (4 REQ.)
17	1307306035		COVER
18	1249306426		GASKET
19	0630302090		SPRING WASHER
19	0636015277		HEXAGON SCREW M8X35
20	1307306046		GEAR SHIFT HOUSING
21	0501206040		GEAR SHIFT DETENT - S5-42/47
	0501206818		GEAR SHIFT DETENT - S5-42 (WITH TAG# 064 OR 103)
22	1307306034		GASKET
23	1307306229		STOP PLATE
24	0631330006		SLOT PIN M5X16
25	0631330131		SLOT PIN M8X22
26	0732041947		COMPRESSION SPRING
27	1307306170		DETENT PIN
28	0732041946		COMPRESSION SPRING
29	0636304047R		PLUG M12X1.5
29	E7TZ7L013A	0630361077	SEALING CAP - (3 REQ.) - S5-42
29	F4TZ7L013A	0630361099	PLUG SEALING 14mm - (3 REQ.) - S5-47
30	0634801027		WASHER
31	0736617043		HEXAGON SCREW
32	1304301035		COVER
33	1290301140		GASKET
34	0501209879		SCREW PLUG M22X1.75
35	0636304049		SCREW PLUG M24X1.5
35	0736304150		SCREW PLUG M24X1.5
35	0501314040		USIT RING
35	0634801206		USIT RING
36	0501209879		SCREW PLUG M22X1.75
37	0636304049		SCREW PLUG M24X1.5
37	0736304150		SCREW PLUG M24X1.5
37	0501314040		USIT RING
37	0634801206		USIT RING
38	1307301011		PIN
39	1307301072		RUBBER CAP
40	1307306062		GEAR SHIFT FINGER
	1317306055		
41	0631329069		SLOT PIN M6X30
42	1307306146		GEAR SHIFT SHAFT
	1317306004		
43	0631329069		SLOT PIN M6X30
44	ZF42-23A	1307206003	3-4 GEAR SHIFT FORK
45	1307306169		3-4 GEAR SHIFT RAIL - S5-42
	1317306006		3-4 GEAR SHIFT RAIL - S5-47
46	ZF42-23	1307298933	1-2 SHIFT FORK ASSEMBLY - S5-42
	ZF47-23	1317298001	1-2 SHIFT FORK ASSEMBLY - S5-47
47	1307306121		COLLAR SCREW
48	1307306230		SHIFTER INTERLOCK

ZF® S5-42 / S5-47 STYLE (cont.)

ILL #	MIDWEST #	REF #	REPLACEMENT PART DESCRIPTION
49	0631329069		SLOT PIN M6X30
50	1307306219		5-REV. GEAR SHIFT RAIL - S5-42
	1317306005		5-REV. GEAR SHIFT RAIL - S5-47
51	ZF42-23B	1307306019	5-REV. GEAR SHIFT FORK
52	0631329069		SLOT PIN M6X30
53	0750115238		BALL SLEEVE
54	1307301015		REAR HOUSING 4X2 - S5-42 GAS (7.5) DIESEL (056, 057, 059)
54	1307301041		REAR HOUSING 4X2 - S542 GAS (4.9/5.8)
54	1307301093		REAR HOUSING 4X4 - S5-42 DIESEL
54	1307301094		REAR HOUSING 4X4 - S5-42 GAS (WITH TAG# 118)
54	1307301136		REAR HOUSING 4X4 - S5-42 (WITH TAG# 108 AND 110)
54	1317301004		REAR HOUSING 4X2 - S5-47 GAS (7.5) DIESEL
54	1317301005		REAR HOUSING 4X4 - S5-47 GAS (4.9/5.8)
54	1317301009		REAR HOUSING 4X2 - S5-47 GAS (4.9/5.8)
54	1317301034		REAR HOUSING 4X4 - S5-47 GAS (7.5) DIESEL
55	1307301148		FIXING PLATE
56	0750101028		CYLINDRICAL PIN
57	19606	0734319609	OUTPUT SEAL 4X2
57	15803	0734310377	OUTPUT SEAL 4X4
58	1307301148		FIXING PLATE
59	0636010374		HEXAGON SCREW M8X55
60	0631306154		CYLINDRICAL PIN M6X25
61	1048301010		MAGNET
62	0501209492		SWITCH
62	0634801260		SEALING RING
63	JH13349	0750117251	POCKET BEARING
64	0730501260 THRU 0730501301		SNAP RING (VARIOUS SIZES - ALSO SOLD IN KIT 1307SRK)
65	ZF42-14	1307304182	3-4-5 SYNCHRONIZER RING - S5-42
	ZF47-14C	1317304150	3-4-5 SYNCHRONIZER RING - S5-47
66	ZF42-111	1307304168	3-4 SYNCHRONIZER BODY - S5-42
	1317304026		3-4 SYNCHRONIZER BODY - S5-47
67	0732041571		COMPRESSION SPRING - (3 REQ.) - S5-42 - CAN USE S542-K, (ONE KIT PER ASSY) OR 1307PPK (ONE KIT FOR ALL ASSY)
	0732042510		COMPRESSION SPRING - (3 REQ.) - S5-47 - CAN USE 1317PPK
68	1307304156		PRESSURE PIECE - (3 REQ.) - S5-42 - CAN USE S542-K, (ONE KIT PER ASSY) OR 1307PPK (ONE KIT FOR ALL ASSY)
	1317304159		PRESSURE PIECE - (3 REQ.) - S5-47 - CAN USE 1317PPK
69	0635460010		BALL - (3 REQ.) - CAN USE S542-K, (ONE KIT PER ASSY) OR 1307PPK (ONE KIT FOR ALL ASSY)
70	ZF42-14	1307304182	3-4-5 SYNCHRONIZER RING - S5-42
	ZF47-14C	1317304150	3-4-5 SYNCHRONIZER RING - S5-47
71	ZF42-116	1307304371	3-4 SLIDING SLEEVE - S5-42
71	ZF47-136A	1317304158	3-4-5-REV. SLIDING SLEEVE - S5-47
72	ZF42-2.5	1307204244	3-4 SYNCHRONIZER ASSEMBLY - S5-42 (HUB & SLIDER ONLY)
	ZF47-2.5	1317204056	3-4 SYNCHRONIZER ASSEMBLY - S5-47 (HUB & SLIDER ONLY)
73	ZF42-11	1307204321	3RD SPEED GEAR - S5-42 (30T) GAS
	ZF42-11A	1307204322	3RD SPEED GEAR (40T) DIESEL
	ZF47-11	1317204007	3RD SPEED GEAR - S5-47 (31T)
73	1317204006		S5-47 3RD GEAR (30T)
74	F206756	0735320871	NEEDLE BEARING 2-3
75	0730162428		BUSHING 3RD GEAR
76	0730106561		WASHER
77	ZF42-21A	1307204319	2ND SPEED GEAR - S5-42 GAS (37T)
	ZF42-21	1307204320	2ND SPEED GEAR - S5-42 DIESEL (51T)
	ZF47-21	1317204024	2ND SPEED GEAR - S5-47 (37T)
78	F206756	0735320871	NEEDLE BEARING 2-3
79	0730501264 THRU 0630531315		SNAP RING (VARIOUS SIZES) - ALSO SOLD IN KIT 1307SRK
80	ZF42-14A	1307304181	1/2 SYNCHRONIZER RING - S5-42
	ZF47-14D	1317304149	1/2 SYNCHRONIZER RING - S5-47
81	ZF42-123	1307304166	1/2 SYNCHRONIZER BODY - S5-42
	1317304031		1/2 SYNCHRONIZER BODY - S5-47
82	0732041571		COMPRESSION SPRING - (3 REQ.) - S5-42 - CAN USE S542-K
	0732042510		COMPRESSION SPRING - (3 REQ.) - S5-47
83	1307304156		PRESSURE PIECE - (3 REQ.) - S5-42 - CAN USE S542-K
	1317304159		PRESSURE PIECE - (3 REQ.) - S5-47

ZF[®] S5-42 / S5-47 STYLE (cont.)

ILL #	MIDWEST #	REF #	REPLACEMENT PART DESCRIPTION
84	0635460010		BALL - (3 REQ.) - CAN USE S542-K
85	ZF42-14A	1307304181	1/2 SYNCHRONIZER RING - S5-42
	ZF47-14D	1317304149	1/2 SYNCHRONIZER RING - S5-47
86	ZF42-128	1307304370	1/2 SLIDING SLEEVE - S5-42
	1317304157		1/2 SLIDING SLEEVE - S5-47
87	ZF42-80	1307204243	1/2 SYNCHRONIZER ASSEMBLY - S5-42 (HUB & SLIDER ONLY)
	1317204055		1/2 SYNCHRONIZER ASSEMBLY - S5-47 (HUB & SLIDER ONLY)
88	1307204298		1ST SPEED GEAR - S5-42
	1317204032		1ST SPEED GEAR - S5-47
89	F206755	0735320873	NEEDLE CAGE, MAIN SHAFT 1/REV.
90	ZF42-2	1307304352	MAIN SHAFT 4X4 - S5-42, 18-3/4"
90	1307304353		MAIN SHAFT 4X4 - S5-42 (118 ONLY)
90	ZF42-2A	1317304066	MAIN SHAFT 4X2 - S5-47, 16-3/8"
91	F206755	0735320873	NEEDLE CAGE, MAIN SHAFT 1/REV.
92	ZF42-36	1307204297	GEAR, MAIN SHAFT REV. - S5-42
	ZF47-36A	1317204015	GEAR MAIN SHAFT REV. - S5-47
93	ZF42-14B	1307304175	REV. SYNCHRONIZER RING - S5-42
	ZF47-14C	1317304038	REV. SYNCHRONIZER RING - S5-47
94	ZF42-131	1307304167	5/4 SYNCHRONIZER BODY - S5-42
	1317304035		5/4 SYNCHRONIZER BODY - S5-47
95	0732041571		COMPRESSION SPRING - (3 REQ.) - S5-42 - CAN USE S542-K
	0732042510		COMPRESSION SPRING - (3 REQ.) - S5-47
96	1307304156		PRESSURE PIECE - (3 REQ.) - S5-42 - CAN USE S542-K
	1317304159		PRESSURE PIECE - (3 REQ.) - S5-47
97	0635460010		BALL - (3 REQ.) - CAN USE S542-K
98	ZF42-14	1307304268	3/4/5 SYNCHRONIZER RING - S5-42
	ZF47-14C	1317304150	3/4/5 SYNCHRONIZER RING - S5-47
99	ZF42-136	1307304372	5/R SLIDING SLEEVE - S5-42
	ZF47-136A	1317304158	5/R SLIDING SLEEVE - S5-47
100	ZF42-40	1307204239	5/R SYNCHRONIZER ASSEMBLY - S5-42 (HUB & SLIDER ONLY)
	1317204057		5/R SYNCHRONIZER ASSEMBLY - S5-47 (HUB & SLIDER ONLY)
101	0630531258 THRU		SNAP RING (VARIOUS SIZES) - ALSO SOLD IN KIT 1307SRK
	0630531315		
102	F209031	0735321010	NEEDLE CAGE, MAIN SHAFT 5TH
103	ZF42-18	1307204323	5TH SPEED GEAR - S5-42 (26T) GAS
	ZF47-18	1317204019	5TH SPEED GEAR - S5-47
	ZF42-18A	1307204324	5TH GEAR - DIESEL
104	0634313136		O-RING
105	0636015299		HEXAGON SCREW M8X20
106	1307302060		QUILL TUBE - S5-42
	1317302010		QUILL TUBE - S5-47
107	3771	0734310378	INPUT SEAL S5-42/47
107	225020	0734319596	INPUT SEAL S5-47M
108	0730105763 THRU		SHIM (VARIOUS SIZES) - ALSO SOLD IN KIT 1307SMK
	0730106689		
109	0501309612		NILOS RING
110	28580-28521	0769170525	INPUT BEARING
111	ZF42-16B	1307202126	INPUT SHAFT - S5-42 GAS (4.9/5.8) 27T, 11-3/4"
	ZF42-16	1307202127	INPUT SHAFT - S5-42 GAS (7.5) 27T, 9-1/2"
	ZF42-16A	1307202128	INPUT SHAFT - S5-42 DIESEL (34T) 9-5/8"
	1317202015		INPUT SHAFT - S5-47 GAS (4.9/5.8)
	ZF47-16B	1317202016	INPUT SHAFT - S5-47 DIESEL (29T) 9-1/2"
	1317202017		INPUT SHAFT - S5-47 GAS (7.5)
112	0501316778		OIL DAM
113	28521-57508	0769170524	OUTPUT BEARING
114	0630501157 THRU		SNAP RING (VARIOUS SIZES) - ALSO SOLD IN KIT 1307SRK
	0630501210		
115	1307204047		SPEEDO GEAR 7T (WHITE)
115	1307204048		SPEEDO GEAR 8T (BLACK)
115	1307304489		SPACER
116	1307304073		YOKE - S5-42
	1317304057		YOKE - S5-47
117	1317304117		LOCKING NUT
118	0730004829 THRU		SHIM (VARIOUS SIZES) - ALSO SOLD IN KIT 1307SMK
	0730006221		
119	0769170314		COUNTERSHAFT BEARING
120	0630501033		SNAP RING 1.75mm

ZF® S5-42 / S5-47 STYLE (cont.)

ILL #	MIDWEST #	REF #	REPLACEMENT PART DESCRIPTION
121	ZF42-9	1307303014	4TH COUNTER GEAR - S5-42 (45T)
	ZF42-9A	1307303015	4TH COUNTER GEAR - S5-47 (41T)
	ZF42-9B	1307303060	4TH COUNTER GEAR - S5-42/S5-47 (43T)
122	1307303109		3RD COUNTER GEAR - S5-42 DIESEL
	1307303110		3RD COUNTER GEAR - S5-42 GAS
	1317303012		3RD COUNTER GEAR - S5-47 GAS
	1317303013		3RD COUNTER GEAR - S5-47 DIESEL
123	1307303115		1-2-REV. COUNTERSHAFT DIESEL
	1317303011		1-2-REV. COUNTERSHAFT GAS
124	1307303112		5TH COUNTER GEAR - GAS
	1307303113		5TH COUNTER GEAR - DIESEL
	1317303016		5TH COUNTER GEAR - S5-47 DIESEL
125	0630501031		SNAP RING 1.75mm
126	ZF42-8	1307203036	COUNTERSHAFT ASSEMBLY - S5-42 GAS
	ZF42-8A	1307203037	COUNTERSHAFT ASSEMBLY - S5-42 DIESEL
	1317203010		COUNTERSHAFT ASSEMBLY - S5-47 GAS
	1317203012		COUNTERSHAFT ASSEMBLY - S5-47 DIESEL
127	0769170314		COUNTERSHAFT BEARING
128	1307305003		IDLER SHAFT PIN
129	0750115233		IDLER NEEDLE CAGE - (2 REQ.)
130	1317305004		IDLER GEAR
131	0636101663		USIT RING - (2 REQ.)
	9639959916		

KITS

T300ZR	→ BEARING, SEAL & GASKET KIT WITH NEEDLES
T300ZRA	→ BEARING, SEAL & GASKET KIT WITHOUT NEEDLES
RK1307/RK1317	→ S5-42/47 RING KIT (GENUINE)
ZF42-SK/ZF47-SK	→ S5-42/47 RING KIT (BRONZE AFTERMARKET)
ZF42-SKS/ZF47-SKS	→ S5-42/47 RING KIT (STEEL WITH BRASS REV. AFTERMARKET)
1307PPK	→ S5-42 PRESSURE PIECE KIT
1317PPK	→ S5-47 PRESSURE PIECE KIT
1307RBK	→ S542/47 SMALL PARTS KIT
1307SRK	→ S5-42/47 SNAP RING KIT
1307SMK	→ S5-42/47 SHIM KIT

**Motive
Gear®**

ZF® S5-47M STYLE

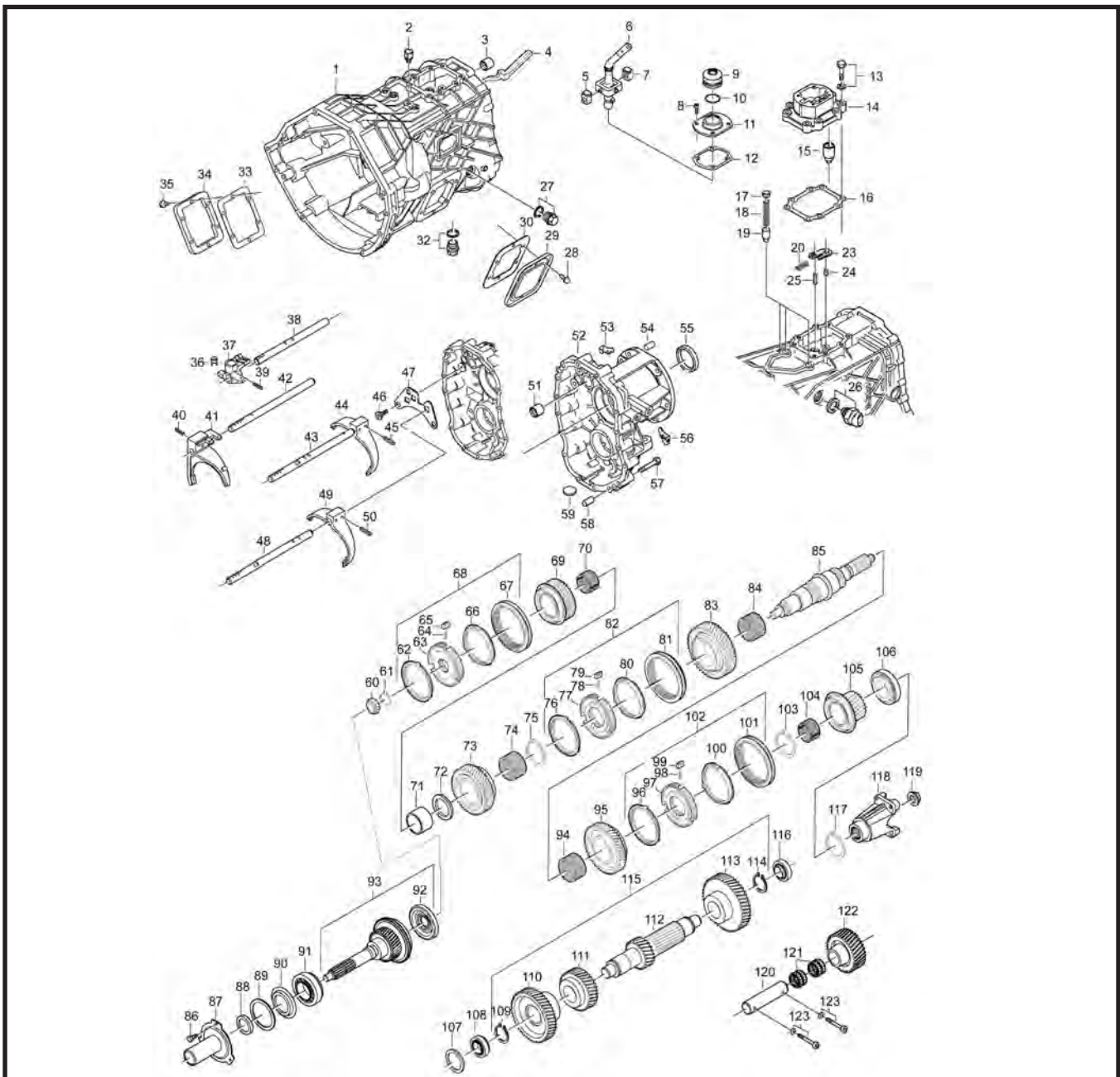

ILL #	MIDWEST #	REF #	REPLACEMENT PART DESCRIPTION
1	1317301016		MAIN HOUSING
2	0501202797		BREATHER
3	0750115238		BALL SLEEVE
4	1319301012		OIL FEEDER
5	1307306154		GUIDE PIECE
6	1317218005		GEAR SHIFT LEVER
	1317218006		
8	0636101679		CAP SCREW M6X16
9	1319306061		INNER TRANS BOOT
10	0730505093		SNAP RING
11	1307306035		COVER
12	1249306426		GASKET
13	0630302090		SPRING WASHER
	0636015277		
14	1307306046		GEAR SHIFT HOUSING
15	0501209895		GEAR SHIFT DETENT

ZF® S5-47M (cont.)

ILL #	MIDWEST #	REF #	REPLACEMENT PART DESCRIPTION
16	1307306034		GASKET
17	0630361077		SEALING CAP - (3 REQ.)
17A	0630361099		PLUG SEALING 14mm - (3 REQ.)
18	0732041946		COMPRESSION SPRING
19	1307306170		DETENT PIN
20	0732041947		COMPRESSION SPRING
23	1307306229		STOP PLATE
24	0631330006		SLOT PIN M5X16
25	0631330131		SLOT PIN M8X22
26	0501209492		SWITCH
26A	0634801260		SEALING RING
27	0501209879		SCREW PLUG
27A	0501314040		USIT RING
	0634801206		
28	0736617043		HEXAGON SCREW
29	1304301035		COVER
30	1290301140		GASKET
32	0501209879		SCREW PLUG
32A	0501314040		USIT RING
	0634801206		
33	1290301140		GASKET
34	1304301035		COVER
35	0736617043		HEXAGON SCREW
36	1317206004		SHIFT ISOLATOR
37	1317306053		GEAR SHIFT FINGER
	1317306055		
38	1317306004		GEAR SHIFT SHAFT
39	0631329069		SLOT PIN M6X30
40	0631329069		SLOT PIN 6X30
41	ZF42-23A	1307206003	GEAR SHIFT FORK 3-4
42	1317306006		GEAR SHIFT RAIL 3-4
44	ZF47-23	1317298001	1-2 SHIFT FORK ASSEMBLY
45	0631329069		SLOT PIN
46	1307306121		COLLAR SCREW
47	1307306230		SHIFT INTERLOCK
48	1317306005		GEAR SHIFT RAIL 5-REV.
49	ZF42-23B	1307306019	GEAR SHIFT FORK 5-REV.
50	0631329069		SLOT PIN 6X30
51	0750115238		BALL SLEEVE
52	1317301017		REAR HOUSING 4X2
	1317301034		REAR HOUSING 4X4
53	1307301148		FIXING PLATE
54	0750101028		CYLINDRICAL PIN
55	19606		OUTPUT SEAL 4X2
	15802		OUTPUT SEAL 4X4
56	1307301148		FIXING PLATE
57	0736010262		HEXAGON SCREW
58	0631306154		DOWEL PIN
59	1048301010		MAGNET
60	0750117251		POCKET BEARING
61	0730501260 THRU 0730501301		SNAP RING (VARIOUS SIZES) - ALSO SOLD IN KIT 1307SRK
62/66	ZF47-14C	1317304150	SYNCHRONIZER RING
63	1317304026		SYNCHRONIZER BODY 3-4
64	0732042510		COMPRESSION SPRING - (3 REQ.)
65	1317304159		PRESSURE PIECE - (3 REQ.)
67	ZF47-136A	1317304158	SLIDING SLEEVE 3-4
68	1317204056		SYNCHRONIZER ASSEMBLY 3-4
69	1317204006		3RD SPEED GEAR
70	F206756	0735320871	NEEDLE BEARING 2-3 GEAR
71	0730162428		BUSHING 3RD GEAR
72	0730106561		WASHER
73	ZF47-21	1317204024	2ND SPEED GEAR
74	F206756	0735320871	NEEDLE BEARING 2ND GEAR
75	0730501264 THRU 0630531315		SNAP RING (VARIOUS SIZES) - ALSO SOLD IN KIT 1307SRK
76	ZF47-14D	1317304149	SYNCHRONIZER RING 1-2

ZF® S5-47M (cont.)

ILL #	MIDWEST #	REF #	REPLACEMENT PART DESCRIPTION
77	1317304031		SYNCHRONIZER BODY 1-2
76	0732042510		COMPRESSION SPRING - (3 REQ.)
79	1317304159		PRESSURE PIECE - (3 REQ.)
80	ZF47-14D	1317304149	SYNCHRONIZER RING 1-2
81	1317304157		SLIDING SLEEVE 1-2
82	1317204055		SYNCHRONIZER ASSEMBLY 1-2
83	1317204032		1ST SPEED GEAR
84	F206755	0735320873	NEEDLE CAGE, MAIN SHAFT 1-REV.
85	ZF42-2A	1317304066	MAIN SHAFT 4X2 - 16-3/8"
	ZF42-2	1307304352	MAIN SHAFT 4X4 - 18-3/4"
86	0636015545		HEXAGON SCREW
87	1317302041		QUILL TUBE
88	3771	0734310378	INPUT SEAL S5-42/47
88	225020	0734319596	INPUT SEAL S5-47M
89	0730105763 THRU 0730106689		SHIM (VARIOUS SIZES) - ALSO SOLD IN KIT 1307SMK
90	0501309612		NILOS RING
91	28580 / 28521	0769170525	INPUT BEARING - CUP & CONE
92	0501316778		OIL DAM
93	1317202033		INPUT SHAFT
94	F206755	0735320873	NEEDLE CAGE, MAIN SHAFT 1-REV.
95	ZF47-36A	1317204015	GEAR, MAIN SHAFT REV.
96	ZF47-14E	1317304038	REV. SYNCHRONIZER RING
97	1317304035		SYNCHRONIZER BODY 5-REV.
98	0732042510		COMPRESSION SPRING - (3 REQ.)
99	1317304159		PRESSURE PIECE - (3 REQ.)
100	ZF47-14C	1317304150	SYNCHRONIZER RING 5-REV.
101	ZF47-136A	1317304158	SLIDING SLEEVE 5-REV.
102	1317204057		5-REV. SYNCHRONIZER ASSEMBLY
103	0630531258 THRU 0630531315		SNAP RING (VARIOUS SIZES) - ALSO SOLD IN KIT 1307SRK
104	F209031	0735321010	NEEDLE CAGE, MAIN SHAFT 5TH
105	1317204018		5TH SPEED GEAR
106	28521-57508	0769170524	OUTPUT BEARING
107	0730004829 THRU 0730006221		SHIM (VARIOUS SIZES) - ALSO SOLD IN KIT 1307SMK
108/116	2580-2520	0769170314	COUNTERSHAFT BEARING
109	0630501033		SNAP RING 1.75mm
110	ZF42-9	1307303014	4TH COUNTER GEAR (45T)
111	1317303012		3RD COUNTER GEAR
112	1317303011		1-2-REV. COUNTERSHAFT
113	1307303112		5TH COUNTER GEAR
114	0630501031		SNAP RING 1.75mm
115	1317203010		COUNTERSHAFT ASSEMBLY
117	0630501157 THRU 0630501210		SNAP RING (VARIOUS SIZES) - ALSO SOLD IN KIT 1307SRK
118	1317304152		FLANGE
119	1317304117		LOCKING NUT
120	1307305003		IDLER SHAFT PIN
121	0750115233		IDLER NEEDLE CAGE - (2 REQ.)
122	1317305004		IDLER GEAR
123	0636101663		CAP SCREW M8X50
123A	0630050016		USIT RING

KITS

T300ZR	→	BEARING, SEAL & GASKET KIT w/ NEEDLES
T300ZRA	→	BEARING, SEAL & GASKET KIT w/o NEEDLES
RK1317	→	SYNCHRO RING KIT (GENUINE)
ZF47-SK	→	SYNCHRO RING KIT (BRONZE/AFTERMARKET)
ZF47-SKS	→	SYNCHRO RING KIT(STEEL WITH BRASS REV. /AFTERMARKET)
1317PPK	→	PRESSURE PIECE KIT
1307RBK	→	SMALL PARTS KIT
1307SRK	→	SNAP RING KIT
1307SMK	→	SHIM KIT

ZF® S6-650 STYLE 6 SPEED

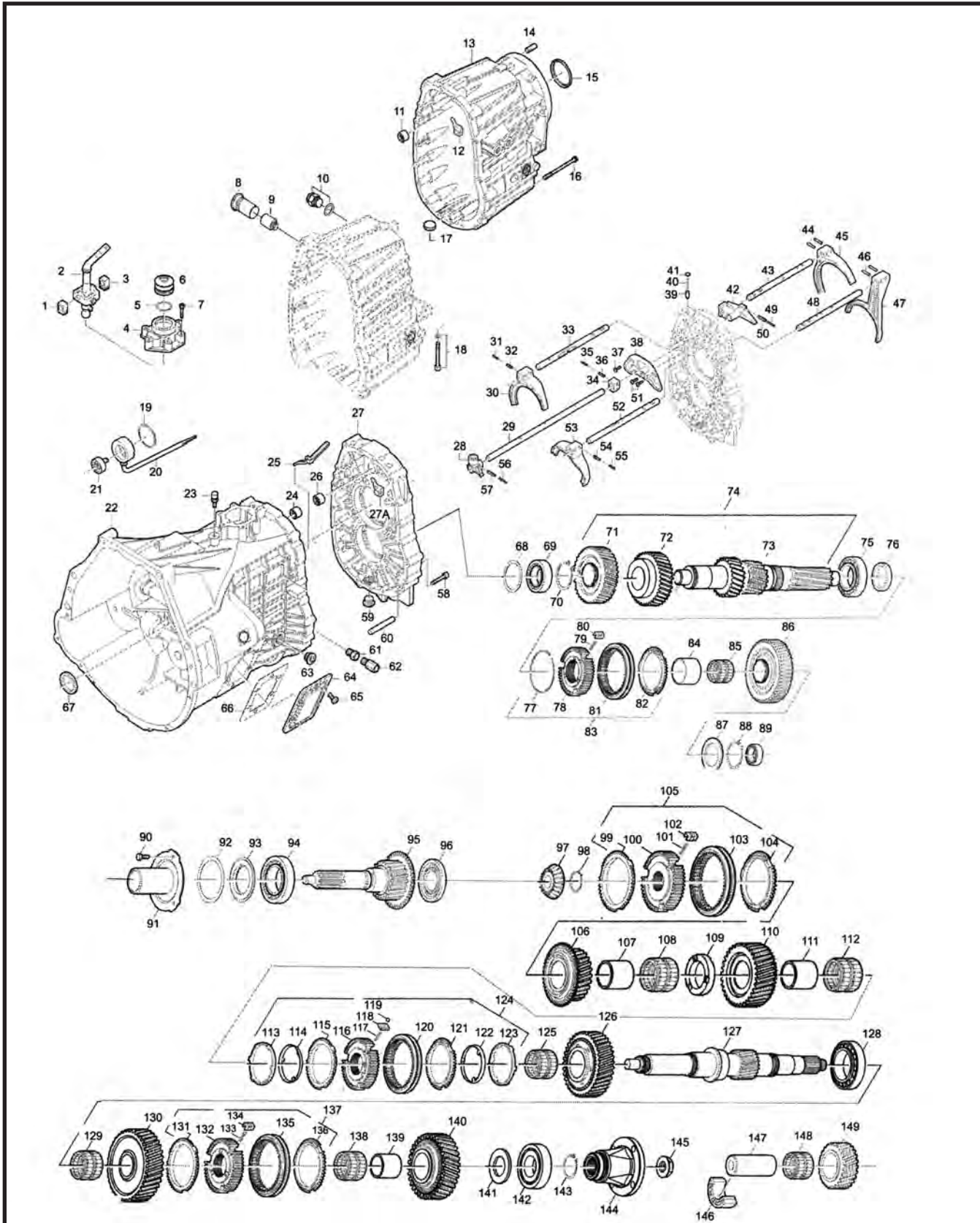

ZF® S6-650 STYLE (cont.)

ILL #	MIDWEST #	REF #	REPLACEMENT PART DESCRIPTION
2	1319218004		GEAR SHIFT LEVER
1/3	1307306154		GUIDE PIECE
4	1319306043		GEAR SHIFT HOUSING
5	0730505093		SNAP RING
6	1319306061		INNER TRANS BOOT
7	0636101356		CAP SCREW M8X35
8	1319306080		MAIN DETENT GUIDE BUSHING
9	0501206040		GEAR SHIFT DETENT
10	0501209492		SWITCH
10	0634801260		SEALING RING
11	0750115238		BALL SLEEVE
12	1307301148		FIXING PLATE
13	1319301021		REAR HOUSING 4X2
13	1319301022		REAR HOUSING 4X4
14	0750101028		CYLINDRICAL PIN
15	0734319677		OUTPUT SHAFT SEAL 4X2
15	0734319598		OUTPUT SHAFT SEAL 4X4
16	0736010258		SCREW
17	1048301010		MAGNET
18	0636101664		CAP SCREW
18	0630050016		USIT RING
19	0630532128		SNAP RING
20	1319220008		PUMP HOUSING
21	0501211188		PUMP SHAFT
22	1319201001		MAIN HOUSING
23	0501202797		BREATHER
24	0750115238		BALL SLEEVE
25	1319301012		OIL FEEDER
26	0750115238		BALL SLEEVE
27	1319301047		INTERMEDIATE HOUSING
27A	1307301148		FIXING PLATE
28	1319306022		SHIFT FINGER FRONT
29	1319306057		MAIN SHIFT RAIL
30	ZF42-23B	1307306019	SHIFT FORK 3-4
31	0631329028		SLOT PIN 3.5X30
32	0631329069		SLOT PIN 6X30
33	1319306051		SHIFT RAIL 3-4
34	1319306034		SHIFT FINGER REAR
34	1319306058		SHIFT DRIVER
35	0631329017		ROLL PIN 3X24
36	0631329050		SLOT PIN 5X24
37	1319306060		COLLAR SCREW
38	1319306048		INTERLOCKING PLATE
39	1307306170		DETENT PIN
40	0732041946		DETENT SPRING
41	0630361099		PLUG SEALING - (4 REQ.)
43	1319306044		CREEPER/REV. SHIFT RAIL
44	0631329069		SLOT PIN 6X30
45	1319306045		CREEPER/REV. SHIFT FORK
46	0631329069		SLOT PIN 6X30
47	1319306047		5TH GEAR SHIFT FORK
48	1319306046		5TH GEAR SHIFT RAIL
49	0631329028		SLOT PIN 3.5X30
50	0631329069		SLOT PIN 6X30
52	1319306050		SHIFT RAIL 1-2
53	ZF42-23B	1307306019	SHIFT FORK 1-2
54	0631329069		SLOT PIN 6X30
55	0631329028		SLOT PIN 3.5X30
56	0631329028		SLOT PIN 3.5X30
57	0631329069		SLOT PIN 6X30
58	0636101663		CAP SCREW
59	0501209879		SCREW PLUG
60	0631306719		CYLINDRICAL PIN
61	0501209815		STOP SCREW
62	0501210762		STOP SCREW
63	0501209879		SCREW PLUG
64	1304301035		COVER

ZF® S6-650 STYLE (cont.)

ILL #	MIDWEST #	REF #	REPLACEMENT PART DESCRIPTION
65	0736617043		HEXAGON SCREW
66	1290301140		GASKET
67	0734319600		INPUT SHAFT SEAL
68	0730005506 THRU 0730005522		SHIM (VARIOUS SIZES) - ALSO SOLD IN KIT 1319SMK
69	1319203021		ROLLER BEARING
70	0630501039		SNAP RING 2.00mm
71	ZFS6-9	1319303049	4TH COUNTER GEAR
72	1319303050		3RD COUNTER GEAR
73	1319303048		1-2 REV. COUNTERSHAFT
74	ZFS6-8	1319203024	COUNTERSHAFT ASSEMBLY (1 PC.)
75	1319203020		INTERM. COUNTERSHAFT BEARING
76	1319303046		SPACER
77	0501317729		SNAP RING
78	1319303047		SYNCHRONIZER BODY
79	0732042510		COMPRESSION SPRING - (3 REQ.)
80	1317304159		PRESSURE PIECE - (3 REQ.)
81	ZF47-136A	1317304158	3-4-5-REV. SLIDING SLEEVE
82	ZF47-14C	1317304150	3-4-5 SYNCHRONIZER RING
83	1319203029		5TH SYNCHRONIZER ASSEMBLY
84	0730162731		BUSHING
85	0735321453		NEEDLE CAGE
86	ZFS6-18	1319303052	5TH SPEED GEAR (54T)
87	1319303045		THRUST WASHER
88	0730501193 THRU 0630501266		SNAP RING (VARIOUS SIZES) - ALSO SOLD IN KIT 1319SRK
89	0735450077		REAR COUNTERSHAFT BEARING
90	0636015545		HEXAGON SCREW
91	1319302009		QUILL TUBE
92	07350005480 THRU 0730005502		SHIM (VARIOUS SIZES) - ALSO SOLD IN KIT 1319SMK
93	1308302029		NILOS RING
94	1319202013		INPUT BEARING
95	ZFS6-16	1319202026	INPUT SHAFT (23T) 10-3/8"
96	0501316778		OIL DAM
97	JH13349	0750117251	POCKET BEARING
98	0630531049 THRU 0630531050		SNAP RING (VARIOUS SIZES) - ALSO SOLD IN KIT 1319SRK
99	ZF47-14C	1317304150	SYNCHRONIZER RING
100	1319304018		SYNCHRONIZER BODY
101	0732042510		COMPRESSION SPRING - (3 REQ.)
102	1317304159		PRESSURE PIECE - (3 REQ.)
103	ZF47-136A	1317304158	SLIDING SLEEVE 3-4
104	ZF47-14C	1317304150	SYNCHRONIZER RING 3-4
105	ZFS6-2.5	1319204025	SYNCHRONIZER ASSEMBLY 3-4 - (HUB & SLIDER ONLY)
106	ZFS6-11	1319204011	3RD SPEED GEAR (27T)
107	0730162812		BUSHING 2-3
108	0735321480		NEEDLE CAGE
109	0730162813		THRUST WASHER
110	1319204013		2ND SPEED GEAR
111	0730162812		BUSHING 2-3
112	0735321480		NEEDLE CAGE
113	1319304075		1-2 INTERMEDIATE RING
114	1319304032		1-2 INTERNAL RING
115	1319304053		1-2 OUTER RING
116	1319304068		SYNCHRONIZER BODY
117	0732042701		COMPRESSION SPRING - (3 REQ.)
118	1319304093		PRESSURE PIECE - (3 REQ.)
119	0635460010		BALL 6mm - (3 REQ.)
120	1319304092		1-2 SLIDING SLEEVE
121	1319304053		1-2 OUTER RING
122	1319304032		1-2 INTERNAL RING
123	1319304075		1-2 INTERMEDIATE RING
124	1319204008		1-2 SYNCHRONIZER ASSEMBLY
125	0735321480		NEEDLE CAGE
126	1319304077		1ST SPEED GEAR
127	1319304070		MAIN SHAFT 4X4 DIESEL WITH TAG# 006

ZF® S6-650 STYLE (cont.)

ILL #	MIDWEST #	REF #	REPLACEMENT PART DESCRIPTION
127	1319304069		MAIN SHAFT 4X2 DIESEL WITH TAG# 005
127	1319304094		MAIN SHAFT 4X4 HIGH TORQUE DIESEL WITH TAG # 025
127	1319304095		MAIN SHAFT 4X2 HIGH TORQUE DIESEL WITH TAG# 024
128	1319204021		ROLLER BEARING
129	0735321404		NEEDLE CAGE, CREEPER/REV. - (2 REQ.)
130	ZFS6-48	1319204027	CREEPER SPEED GEAR (41T)
131	ZFS6-14D	1317304149	CREEPER/REV. SYNCHRONIZER RING
132	1319304019		CREEPER/REV. SYNCHRONIZER BODY
133	0732042510		COMPRESSION SPRING - (3 REQ.)
134	1317304159		PRESSURE PIECE - (3 REQ.)
135	1317304157		CREEPER/REV. SLIDING SLEEVE
136	ZF47-14D	1317304149	CREEPER/REV. SYNCHRONIZER RING
137	ZFS6-40	1319204024	CREEPER/REV. SYNCHRONIZER ASSEMBLY - HUB & SLIDER ONLY
138	0735321404		NEEDLE CAGE, CREEPER/REV. - (2 REQ.)
139	0730162730		REVERSE BUSHING
140	ZFS6-36	1319204026	REVERSE SPEED GEAR
141	0730109432		THRUST WASHER 5.0mm
142	0735330284		OUTPUT BEARING
143	0630531058 THRU 0730501499		SNAP RING (VARIOUS SIZES) - ALSO SOLD IN KIT 1319SRK
144	1319204030		CIRCULAR FLANGE
145	1317304117		LOCKING NUT
146	1319305006		SUPPORT
147	1319305007		REV. IDLER SHAFT
148	0735321455		NEEDLE BEARING BUSHING - (2 REQ.)
149	1319305010		IDLER GEAR
N.I.	0501212997		CHECK VALVE (IN CASE)

KITS

T1319R	→ BEARING, SEAL & GASKET KIT w/ NEEDLES
T1319RA	→ BEARING, SEAL & GASKET KIT w/o NEEDLES
1319PPK	→ PRESSURE PIECE KIT
1319SK	→ SYNCHRO RING KIT (GENUINE)
ZFS6-SKS	→ SYNCHRO RING KIT (STEEL w/ BRASS REV. AFTERMARKET)
1319RBK	→ SMALL PARTS KIT
1319SMK	→ SHIM KIT
1319SRK	→ SNAP RING KIT

**Motive
Gear®**

T45 STYLE

1996-1999 FORD® MUSTANG COBRA

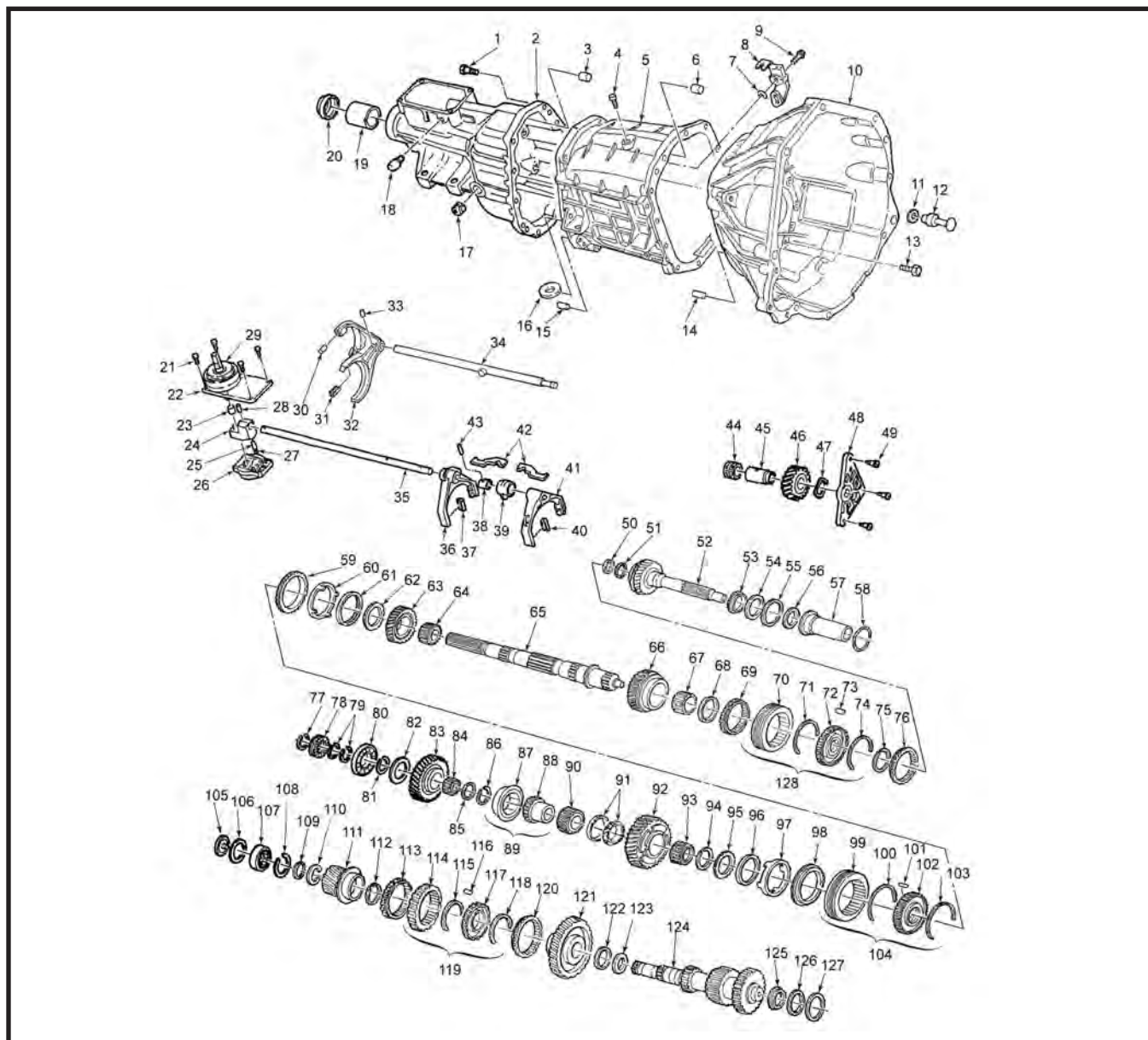

ILL #	MIDWEST #	REF #	REPLACEMENT PART DESCRIPTION
1/13	1381183001		BOLT
2	1381566003		EXTENSION HOUSING ASSY - MUSTANG GT
2	1381566004		EXTENSION HOUSING ASSY - MUSTANG, COBRA
2	1381566012		EXTENSION HOUSING ASSY - MUSTANG - ALL, 1999-ON
2	1381566001		EXTENSION HOUSING ASSY & BUSHING - GT
2	1381566002		EXTENSION HOUSING ASSY & BUSHING - COBRA
2	1381566011		EXTENSION HOUSING & BUSHING - ALL, 1999-ON
3/6	1900127006		BUSHING - SHIFT RAIL
4	1386183003		BOLT, INTERLOCK
5	1381565001		MAIN CASE ASSY
7	1332139003		REVERSE LEVER RETAINER
8	1381098001		REVERSE LEVER
9	1352183002		BOLT, PIVOT
10	1381172001		CLUTCH HOUSING
10	1381172003		CLUTCH HOUSING - 1999-ON
10	1381672001		CLUTCH HOUSING ASSY - INCLUDES TUBE, SEAL, DOWEL
10	1381672003		CLUTCH HOUSING ASSY - 1999-ON - INCLUDES TUBE, SEAL, DOWEL
11			WASHER

T45 STYLE (cont.)

ILL #	MIDWEST #	REF #	REPLACEMENT PART DESCRIPTION
12	1381146001		CLUTCH ARM PIVOT STUD
14/15	1381043001		DOWEL
16	4915-E		MAGNET
17	1300052007		PLUG - FILL/DRAIN
18	1300072005		BREATHER
19	1381127002		BUSHING - EXTENSION
20	1300044020	710431	SEAL - REAR OUTPUT
21	1351183001		BOLT - SHIFTER
22	1352598107		SHIFTER ASSY
23	1352127009		BUSHING
24	1351098009		OFFSET LEVER
25	1351156001		SPRING - DETENT
26	1352014005		GUIDE PLATE
27	453593		BALL
28	1000043016		ROLL PIN
29	1386021001		SHIFTER BOOT
30	1356235001		FORK PAD
31	1352127008		FORK PAD
32	1381596003		SHIFT FORK ASSY - PADS 5-REV.
32	1381096003		SHIFT FORK 5-REV.
33/43	1332043004		PIN
34	1381600001		RAIL, PIN & ROLLER ASSY
35	1381100001		MAIN SHAFT RAIL
36	1381596001		SHIFT FORK ASSY - PADS 1-2
36	1381096001		SHIFT FORK 1-2
37/40	1386235001		FORK PADS 1-2, 3-4
38	1352096016		SELECTOR
39	1381014001		INTERLOCK
41	1381596004		SHIFT FORK ASSY - PADS 3-4
41	1381096004		SHIFT FORK 3-4
42	1381190001		SHIFT PLATE
44	1381132001		BEARING - REVERSE IDLER
45	1381068001		SHAFT - REVERSE IDLER
46	1381084001		REVERSE IDLER GEAR
47			THRUST WASHER
48	1381185001		BRACKET - REVERSE IDLER
49	1386183002		BOLT - IDLER BRACKET
50/94	LM11749		BEARING - M/S PILOT
51	LM11710		RACE - M/S PILOT
52	1381085001		INPUT SHAFT
53	M88048		BEARING - INPUT
54	M88010		RACE - INPUT
55/127	1386037005 THRU 1386037005		SHIM - INPUT (VARIOUS THICKNESS)
56	7412S	1300044015	SEAL - INPUT
57	1386034006		GUIDE TUBE
57	1381034001		GUIDE TUBE - 1999-ON
58	1300141134		O-RING
59/98	1386091001		BLOCKER RING 1-2 SYNCHRO
60/97	1381525001		DOUBLE DONE 1-2 SYNCHRO
61/96	1386025001		INNER CONE 1-2 SYNCHRO
62/95	1386193002		THRUST WASHER - 1-2 SYNCHRO
63	1381082001		GEAR - 2ND M/S - 35T
64			NEEDLE BEARING, 2ND GEAR
65	1381171001		MAIN SHAFT - 24-3/4" O.A., 31 SPL.
66	1381083001		GEAR - 3RD M/S - 32T
67	1300132009		NEEDLE BEARING, 3RD GEAR
68	1386053008		SPACER, 3RD GEAR BEARING
69/120	1381591002		SYNCHRO RING 5-REV.
70	1386089002		SYNCHRO SLEEVE 3-4
71/103	1386156003		SYNCHRO SPRING 3-4
72	1386090004		SYNCHRO HUB 3-4
73/116	1351093001		SYNCHRO KEY 3-4
74/113	1352156018		SYNCHRO SPRING 5-REV.
75/77			SNAP RING
76	1381591001		SYNCHRO RING 3-4
78	1381110001		SPEEDOMETER DRIVE GEAR
79/81/86			SNAP RING

T45 STYLE (cont.)

ILL #	MIDWEST #	REF #	REPLACEMENT PART DESCRIPTION
80	207		BEARING, M/S REAR
82	1386193004		THRUST WASHER REV. - M/S
83	1381088001		GEAR REV. M/S
84			NEEDLE BEARING
85	1386053001		SPACER REV. - M/S
87	1381089001		SYNCHRO COLLAR - REV.
88	1381090002		SYNCHRO HUB - REV.
89	1381590002		SYNCHRO ASSY - REV.
90	1381070001		GEAR - 5TH M/S - 31T
91	25520		RACE - REAR M/S BEARING
91	25572		BEARING - REAR M/S BEARING
92	1381081001		GEAR - 1ST M/S - 37T
93	1386132002	FC67379	NEEDLE BEARING - 1ST BEARING
99	1386089001		SYNCHRO COLLAR 1-2
100/115/118	1386156001		SYNCHRO SPRING 1-2
101	1386093001		SYNCHRO KEY 1-2
102	1386090001		SYNCHRO HUB 1-2
104	1386590001		SYNCHRONIZER 1-2
105	1386034002		FUNNEL
106			THRUST WASHER
107	F92214.3		BEARING, C/S EXTENSION
108			SNAP RING
109			THRUST WASHER
110			SNAP RING
111	1381088002		REVERSE GEAR, C/S 14T
112	1300139043		SNAP RING, C/S REAR BEARING
114	1352089003		SYNCHRO SLEEVE 5-REV.
117	1381090001		SYNCHRO HUB 5-REV.
119	1381590001		REV. SYNCHRO ASSY (ON M/S)
121	1381086001		GEAR - 5TH C/S
124	1381077001		CLUSTER GEAR
128	1386590002		SYNCHRO ASSY 3-4
122	1381110002		ROTOR - SPEEDO SENSOR 1999-ON
122/126	LM11910		RACE - FRONT AND REAR C/S BEARING
123/125	LM11949		BEARING - FRONT AND REAR C/S BEARING

KITS

T520R	→ BEARING KIT - ALL
T520RMK	→ BEARING MASTER KIT - INCLUDES RINGS
RK45	→ SYNCHRO RING KIT
SP45-50	→ SMALL PARTS KIT
K520	→ GASKET & SEAL KIT

TREMEC® T150 STYLE

3 SPEED

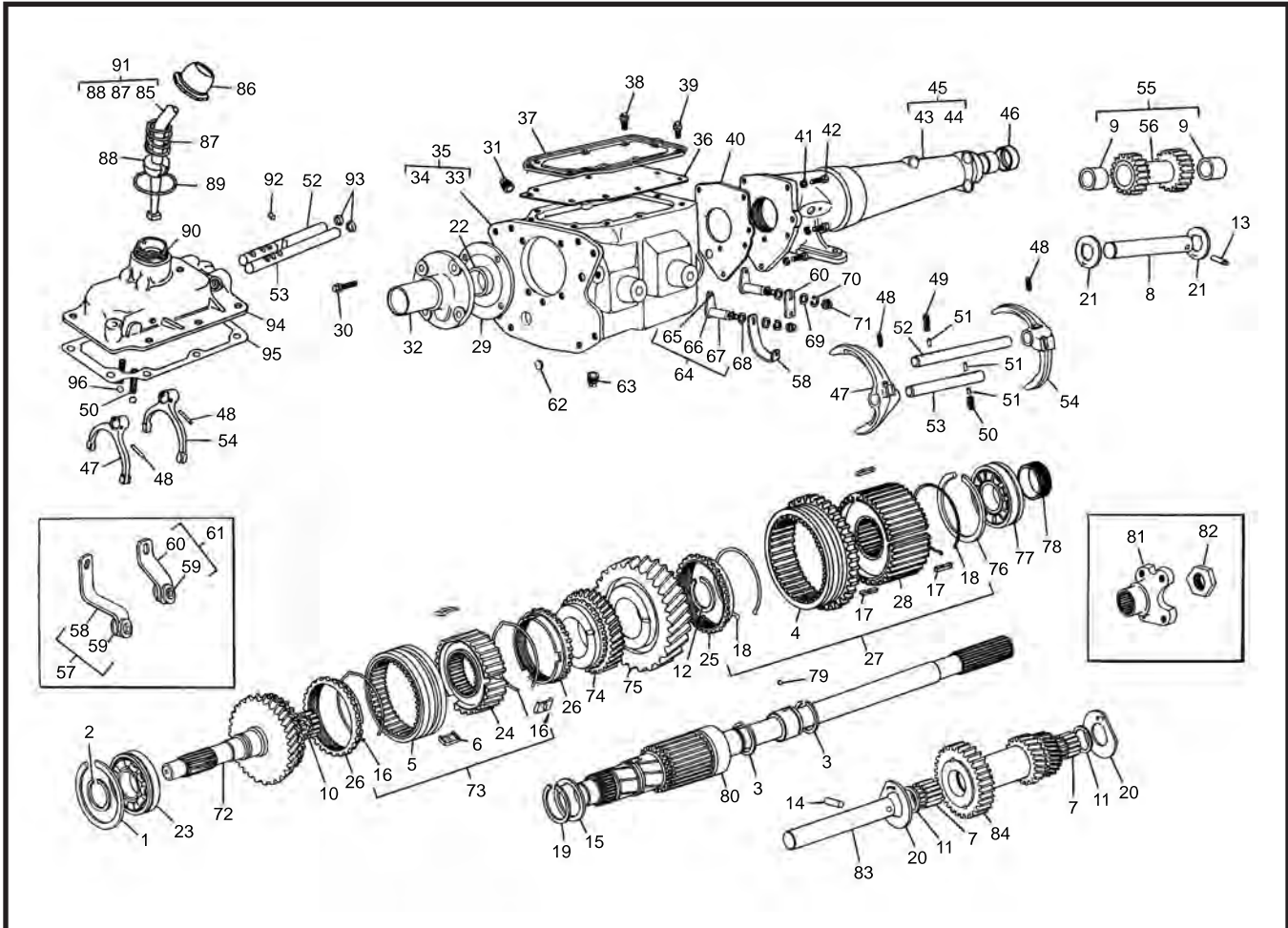

ILL #	MIDWEST #	REF #	REPLACEMENT PART DESCRIPTION
-------	-----------	-------	------------------------------

4	2601166		1ST & REVERSE SYNCHRO SLIDING GEAR
5	2601170		2ND & 3RD SYNCHRO SLIDING GEAR
6	2601178	8124895 / C3AZ7A044A	2ND & 3RD SYNCHRO INSERT
8	2601183	8124912 / C3AZ7140A	REVERSE IDLER SHIFT
16	2602703	8124896 / B8AZ7109B	2ND & 3RD SYNCHRO SPRING
17	2602831	8124904 / C3AZ7A044B	1ST & REVERSE SYNCHRO INSERT
18	2602832	8124905 / C3AZ7109D	1ST & REVERSE SYNCHRO SPRING
22	482208		FRONT SEAL - AMC*
	482208		FRONT SEAL - FORD*
23	208L		INPUT BEARING - AMC
23	208L		INPUT BEARING - FORD
24	2603545		2ND & 3RD SYNCHRO HUB
25	2603658	8132381	1ST & REVERSE SYNCHRO RING
26	2603659	8124897 / C4A27107B OR C	2ND & 3RD SYNCHRO RING
27	2670085	8126234 / C6AZ7124B	1ST & REVERSE SYNCHRO RING
32	2603001	8124880 / C5AZ7050E	FRONT BEARING RETAINER
32	2602553	C5AZ7050F	FRONT BEARING RETAINER
32	2603771	D8BZ7050A	FRONT BEARING RETAINER
33	2603983	8126808	MAIN CASE - 4X4
33	2603268	8124890	MAIN CASE - ALL
33	2603203	D2ZZ7005B	MAIN CASE
37	2603027	8124884 / C3AZ7222B	TRANSMISSION CASE COVER
46	410059		REAR SEAL EXT. FORD*
46	482267		REAR SEAL EXT. AMC*
47	2603353	8124920 / C3AZ7230B	2ND & 3RD SHIFT FORK - AMC, FORD
47	2602544	C3AZ7230C	2ND & 3RD SHIFT FORK - FORD
47	2602765	C80Z7230A	2ND & 3RD SHIFT FORK - FORD

TREMEC® T150 STYLE (cont.)

ILL #	MIDWEST #	REF #	REPLACEMENT PART DESCRIPTION
48	2601227	8124918 / 377888-S	SHIFT FORK ROLL PIN
49	2602557	8124923 / C8AZ7234A	FORK SPRING
50	2602448	8124924 / C7AZ7234A	FORK SPRING
51	2602894	8124925 / C0AZ7C316A	PLUNGER
51	2603058	D3T27C316A	PLUNGER
52	2602890	D0AZ7240E	1ST & REVERSE SHIFT RAIL, 3-3/4 X 9/16 O.D.
52	2603286	D3TZ7240F	1ST & REVERSE RAIL, 6-3/4 X 9/16 O.D.
52	2603056	D3TZ7240E	1ST & REVERSE RAIL, 6-3/4 X 9/16 O.D.
52	2603350	8126823	1ST & REVERSE SHIFT RAIL, AMC TOP SHIFT
52	2602889	8124922 / D0AZ7240D	1ST & REVERSE SHIFT RAIL, 5-9/16 X 9/16 O.D.
53	2602987	8124921 / D2AZ7240A	2ND & 3RD SHIFT RAIL
53	2603185	D2OZ7241A	2ND & 3RD SHIFT RAIL, AMC ALL, SIDE SHIFT
53	2603351	8126824	2ND & 3RD SHIFT RAIL, TOP SHIFT
54	2601193	8124919 / C3AZ7231A	1ST & REVERSE FORK, 1963-78 FORD, 1976-79 AMC
54	2603352	8126825	1ST & REVERSE FORK, AMC ALL, SIDE SHIFT
54	2602543	C3AZ7231D	1ST & REVERSE FORK - FORD
55	2601184	8124913 / 210080 / C5A7141C	REVERSE IDLER GEAR, FORD*, S19-L17
57	2603397	D5BZ7285A	2ND & 3RD RELAY LEVER ASSY - FORD
58	2602839	D0ZZ7285B	2ND & 3RD RELAY LEVER - FORD
58	2603049	D3TZ7285A	2ND & 3RD RELAY LEVER - FORD
61	2603395	D5BZ7290B	1ST & REV. RELAY LEVER ASSY - COL. SHIFT
61	2603808	D8BZ7290A	1ST & REV. RELAY LEVER ASSY - COL. SHIFT - 6 CYL. PASS FL SHIFT F SERIES
61	2603048	D3TZ290A	1ST & REV. RELAY LEVER ASSY - COL. SHIFT - 6 CYL. PASS FL SHIFT E SERIES
61	2603508	D5UZ7290A	1ST & REV. RELAY LEVER ASSY - COL. SHIFT - 6 CYL. PASS FL SHIFT F SERIES.
61	2604845	E2TZ7290A	1ST & REV. RELAY LEVER ASSY - COL. SHIFT - 6 CYL. PASS FL SHIFT E SERIES.
61	2604804	E2UZ7290A	1ST & REV. RELAY LEVER ASSY - COL. SHIFT - 6 CYL. PASS FL SHIFT E SERIES.
64	2602571	8124916 / C3AZ7C124A	GEAR SHIFT LEVER ASSY
70	2605108		LEVER SHAFT LOCK WASHER - ALL
71	2D-06	3878192 / 33800-58	NUT - ALL
72	2603158	8126106	MAIN DRIVE - AMC* TOP SHIFT, 9-5/8, L20-S33
72	2601151	C5AZ7017B	MAIN DRIVE, 8-3/4, 20-33
72	2602762	C8AZ7017A	MAIN DRIVE, 8-5/16, 20-33
72	2602522	C8AZ7017B	MAIN DRIVE, 8-5/16, 22-36
72	2602762	D5TZ7017A	MAIN DRIVE, 8-15/16, 20-33
72	2603639	D7TZ7017A	MAIN DRIVE, 8-15/16, 19-33
72	2603620	D7BZ7017A	MAIN DRIVE, 8-3/4, 18-33
72	2603776	D8BZ7017A	MAIN DRIVE, 9-27/64, 18-33
73	2670091	8122635 / D5OZ7124A	2ND & 3RD SYNCHRO ASSY, TOP SHIFT, 33-32, 3-9/16 O.D.
73	2604399	C8TZ7124H	2ND & 3RD SYNCHRO ASSY, 3-15/16 O.D., 36T 32 SPL.
74	2603199	8124899 / D5AZ7102F	2ND GEAR, L25-33T
74	2603443	C5TZ7102D	2ND GEAR, 25-34 OR 36
74	2602534	C4AZ7102G	2ND GEAR, 27-36
74	2603129	C8AZ7102A	2ND GEAR, 25-33
74	2603628	D7BZ7102A	2ND GEAR CAR, 24-33
75	2603200	8124902 / C5AZ7A029A OR C	1ST GEAR, L32-S36
75	2602535	C5AZ7A029B	1ST GEAR, 2.03 WIDE, 32-36
77	307L		M/S REAR BRG - AMC*
77	207L		M/S REAR BRG - FORD*
78	2603777	D8BZ7061A	MAIN SHAFT ASSY, 32-37-28, 23-11/16L
80-ON	2604355	E0TZ7061F	MAIN SHAFT ASSY, S32-37-28, 23-1/2L
ALL	2603039		MAIN SHAFT NUT
80	2602876	8126804	MAIN SHAFT ASSY - AMC, S32-36-6, 11-1/4L
80	2602872	8124889	MAIN SHAFT ASSY - AMC*, w/o O.D., S32-37-28, 23-11/16L
80	2603324	8126044	MAIN SHAFT ASSY - AMC, w/ O.D., S32-37-25, 20-5/8L
80	2602872	D0DZ7061A	MAIN SHAFT ASSY - PASS CAR, S32-37-28, 23-11/16L
80	2602873	D0TZ7061A	MAIN SHAFT ASSY - S32-37-28, 16-9/32L
80	2603018	D0AZ7061A	MAIN SHAFT ASSY - S32-37-28, 23-11/16L
80	2602769	D0TZ7061B	MAIN SHAFT ASSY - 32-37-28, 17-7/16L
80	2603217	C5TZ061C / D0TZ7061C	MAIN SHAFT ASSY - 32-37-28, 16-19/32L
80	2603218	D0TZ7061D	MAIN SHAFT ASSY - 32-37-28, 17-3/4L
80	2670116	C5UZ7061A	MAIN SHAFT ASSY - 32-37-28, 13-9/16L

TREMEC® T150 STYLE (cont.)

ILL #	MIDWEST #	REF #	REPLACEMENT PART DESCRIPTION
80	2602883	D0AZ7061C	MAIN SHAFT ASSY - 32-37-28, 23-1/2L
83	2601175	8124911 / C3AZ7111B	COUNTER SHAFT, 6-9/32, .8685
83	2603184	C7ZZ7111A	COUNTER SHAFT, 6", .8685
83	2602540	C3AZ7111C	COUNTER SHAFT, 7", .8685
84	2603201	8124907	CLUSTER GEAR, R28-20-15
84	2602764	C5TZ7113H	CLUSTER GEAR, R28-20-15
84	2603641	D7TZ7113A	CLUSTER GEAR, R29-20-15
84	2603629	D7BZ7113A	CLUSTER GEAR, PASS, R30-21-15
92	2602870	D0AZ7235A OR D / 2100502	LOCK PLUNGER - ALL
94	2603349		TOP COVER - AMC

KITS

NI	→	SMALL PARTS KIT
NI	→	GASKET KIT - AMC*, ALL
NI	→	GASKET KIT - FORD*

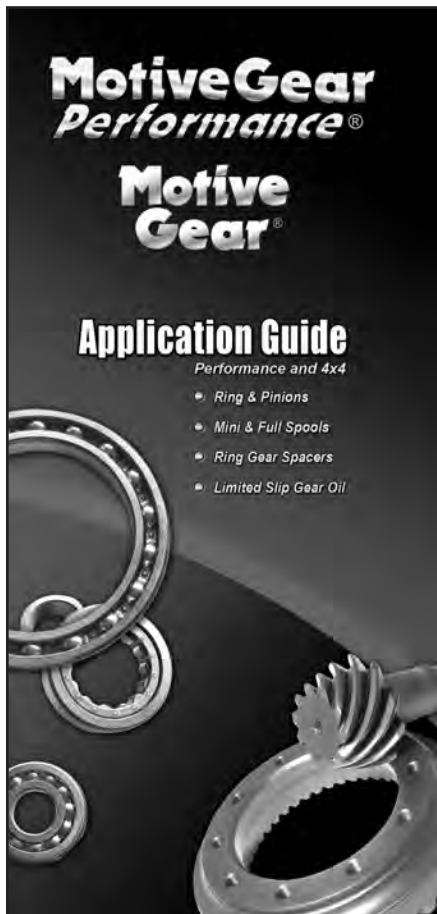

Light Duty & Performance Application Guide

This catalog features stock performance and high performance ring and pinions for street, track, and off road applications; as well as installation components: axles, hubs, gear oils, posi units, lockers, spools, ring gear spacers, bearing kits, gaskets, and more!

TREMEC® T170 STYLE 4 SPEED

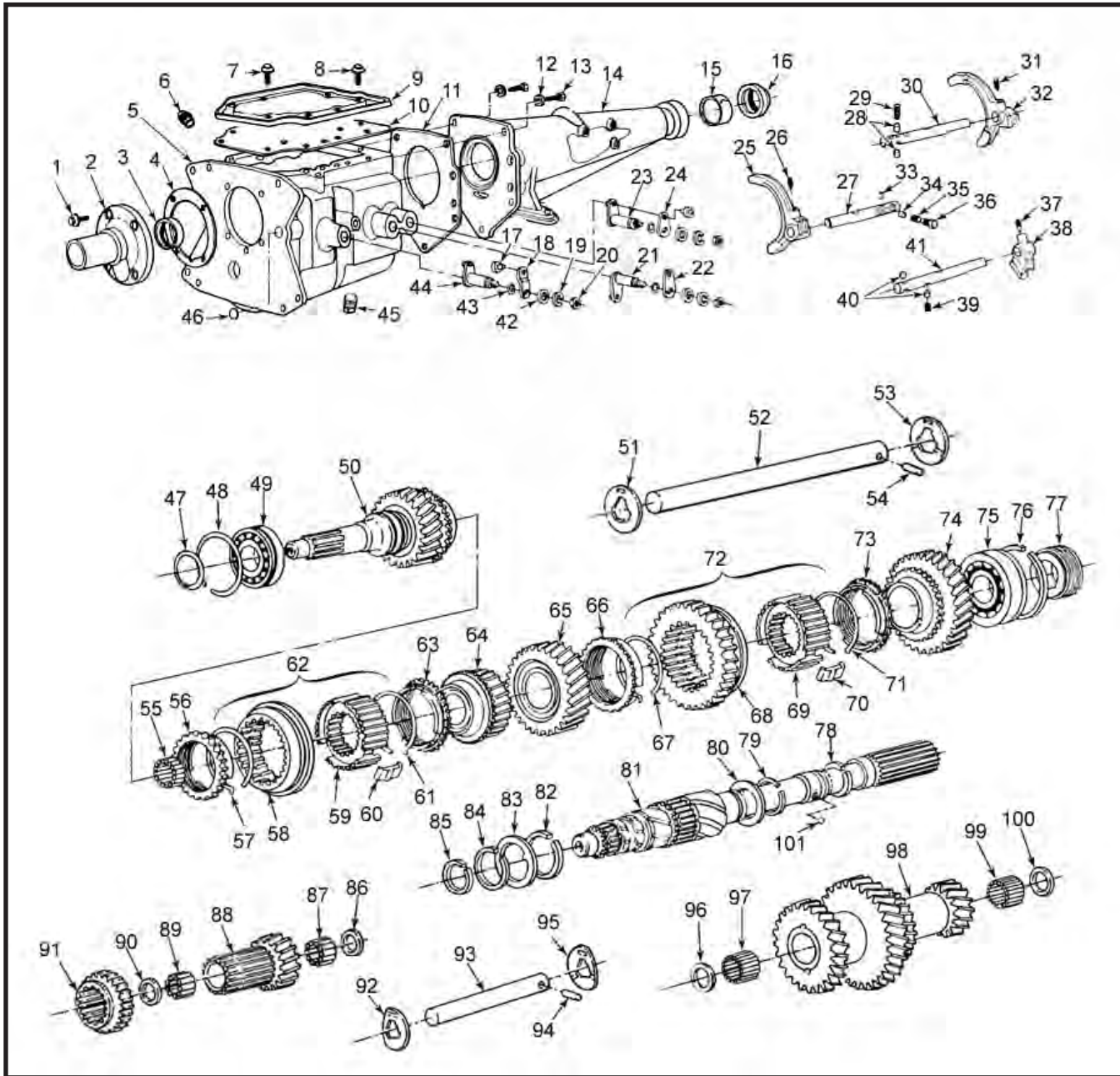

TREMEC® T170 STYLE (cont.)

ILL #	MIDWEST #	REF #	REPLACEMENT PART DESCRIPTION
2	2605314	E0TZ7050A / WT170-6C	RETAINER - FRONT BEARING FORD TRUCK
2	2602885	8132372 / WT170-6G	RETAINER - FRONT BEARING JEEP - 9-5/8" INPUT FORD CAR - 8-7/8" INPUT - 4-7/8" O.D.
2	2604215	8132373 / T170-6H	RETAINER - FRONT BEARING JEEP - 13-1/2" INPUT
2		C4AZ7050A	RETAINER - FRONT BEARING FORD CAR - 8-3/8" OR 8-15/16" INPUT - 4-11/16" O.D.
2		C5AZ7050J	RETAINER - FRONT BEARING FORD CAR - 8-3/8" OR 8-15/16" INPUT - 4-7/8" O.D.
2		C4AZ7050B	RETAINER - FRONT BEARING FORD CAR - 7/16" INPUT - 4-1/16" O.D.
2	WT296-6A	C5AZ7050K	RETAINER - FRONT BEARING FORD CAR - 8-7/16" INPUT - 4-7/8" O.D.
2	2603901	D9DZ7050A / WT170-6G	RETAINER - FRONT BEARING FORD CAR - 8-7/8" INPUT - 1979-83 SROD
2	2603828	D9BZ7050A WT170-6A	RETAINER - FRONT BEARING FORD CAR - 9-9/16" INPUT - 1979-83 SROD 4-7/8" O.D. 4-7/8" O.D.
2	2603900	D9ZZ7050A	RETAINER - FRONT BEARING FORD CAR - 11" INPUT -1979-83 SROD
3	3638	11123	FRONT SEAL - ALL
5	WT170-1F	E4TZ7005B	MAIN CASE - FORD TRUCK/BRONCO 1984-86 ALUM. CASE O.D.
5	WT170-1D	E0TZ7005C	MAIN CASE - FORD TRUCK/BRONCO 1980-83 ALUM. CASE O.D.
5	WT170-1B	D8OZ7005A	MAIN CASE - FORD VAN 1980-83 CAST IRON O.D.
5	WT170-1E	8132375	MAIN CASE - JEEP 1980-83
5	WT170-1A	D9BZ7005A	MAIN CASE - FORD CAR ALL - ALUM. O.D.
15	1000127017	WT259-62	BUSHING FORD 1.50" I.D.
16	9613S	15041	REAR SEAL FORD TRUCK/CAR 1.50" I.D.
16	473234	16871	REAR SEAL FORD CAR 31 SPL. 1.69" I.D.
16	472439	18580	REAR SEAL JEEP - ALL
32	2604954	8132411 / WT170-23E	FORK 1-2 JEEP - ALL
32	2604159	8132412 / WT170-23F	FORK 3-4 JEEP - ALL
32	2604160	8132413 / WT170-23G	FORK REV. JEEP - ALL
32	2607667	C4AZ7230B / WT296-23	FORK 1-2 FORD CAR/TRUCK - IRON CASE
32	2604761	E1TZ7230A / WT170-23	FORK 1-2 FORD CAR/TRUCK - ALUM. CASE
32	2602666	C4AZ7230A / WT296-23A	FORK 3-4 FORD CAR/TRUCK - IRON CASE
32	2604663	E1ZZ7230B / WT170-23A	FORK 3-4 FORD CAR/TRUCK - ALUM. CASE
32	2602668	T170-22C / C4AZ7231B	FORK REV. FORD CAR/TRUCK - IRON CASE
32	2603860	D9BZ7231A / WT170-23B	FORK REV. FORD CAR/TRUCK - ALUM. CASE
43	A5111		O-RING - SHIFT SHAFT - IRON CASE
43	313156	5510	SHIFT SHAFT SEAL - ALUM. CASE
49	209L		INPUT BEARING - JEEP - ALL
49	308L4		INPUT BEARING - FORD TRUCK
49	209L		INPUT BEARING - FORD CAR
50	2604201	8132369 / T170-16Q	INPUT SHAFT JEEP 20T - 9-5/8" O.A.
50	2604214	8132370 / T170-16R	INPUT SHAFT JEEP 22T - 13-1/2" O.A.
50	2604209	8132401 / T170-16S	INPUT SHAFT JEEP 19T - 9-5/8" O.A.
50	2604692	8133434 / T170-16T	INPUT SHAFT JEEP 20T - 13-1/2" O.A.
50	2604484	T170-16F / T170-16N / D8UZ7017A / E0TZ7017B	INPUT SHAFT FORD TRUCK 21T - 8-7/8" O.A. - CAN USE 2604484
50	2603806	T170-16G / D8UZ7017B	INPUT SHAFT FORD TRUCK 22T - 8-7/8" O.A.
50	WT296-16	C4AZ7017G	INPUT SHAFT FORD CAR 23T - 8-3/8" O.A. CLOSE RATIO 2.32 TO 1 - 390
50	WT296-16A	C4AZ7017H	INPUT SHAFT FORD CAR 23T - 8-7/16" O.A. CLOSE RATIO 2.32 TO 1 - 427/428/429
50	2602612	C4DZ7017A / WT296-16B	INPUT SHAFT FORD CAR 23T - 8-15/16" O.A. WIDE RATIO 2.78 TO 1
50	WT296-16C	C4OZ7017A	INPUT SHAFT FORD CAR 23T - 8-5/16" O.A. CLOSE RATIO 2.32 TO 1
50	WT296-16D	C4MY7017A	INPUT SHAFT FORD CAR 23T - 8-3/8" O.A. WIDE RATIO 2.78 TO 1 - 390
50	2603596	T170-16E / D7DZ7017A	INPUT SHAFT FORD CAR 24T - 8-7/8" O.A. GRANADA/MONARCH, 1977-78
50	2603827	T170-16H / D9BZ7017A	INPUT SHAFT FORD CAR 24T - 9-5/8" O.A. 1979-83 - 6 CYL.
50	2603926	T170-16J / D9BZ7017B	INPUT SHAFT FORD CAR 25T - 9-5/8" O.A. 1979-83 - 8 CYL.
50	2603899	T170-16K / D9DZ7017A	INPUT SHAFT FORD CAR 24T - 8-7/8" O.A. GRANADA/MONARCH, 1979-83 6 CYL.
50	2603925	T170-16L / D9DZ7017B	INPUT SHAFT FORD CAR 25T - 8-7/8" O.A. GRANADA/MONARCH, 1979-83 8 CYL.
50	2603898	T170-16M / D9ZZ7017A	INPUT SHAFT FORD CAR 24T - 11-1/16" O.A. MUSTANG/CAPRI - 1979-83 6 CYL.
52	2602657	WT296-3	COUNTERSHAFT - ALL
55	C417Q		INPUT PILOT ROLLERS (15 REQ.)
56	T170-14A	2605123/2605124	SYNCHRO RINGS - 1-2-3-4 - IRON CASE
56	WT287-83	T91L-14A/2603658	SYNCHRO RINGS 1-2-3-4 - ALUM. CASE
57	2605117	WT296-78	SYNCHRO SPRINGS - ALL
58	2605141	WT296-15	SYNCHRO SLEEVE - ALL
60	2601178	WT150-77	SYNCHRO KEYS 3-4 - ALL
62	2670166	1AT170-2.5A	3-4 SYNCHRO ASSY. - RINGS - USE WITH IRON CASE
62	2670162	1AT170-2.5B	3-4 SYNCHRO ASSY. - RINGS - USE WITH ALUM. CASE

TREMEC® T170 STYLE (cont.)

ILL #	MIDWEST #	REF #	REPLACEMENT PART DESCRIPTION
64	2604250	T170-11M / 8132429	3RD GEAR JEEP® - 22T
64	2604149	T170-11K / 8132379	3RD GEAR JEEP - 23T
64	2604253	T170-11L / 8132380	3RD GEAR JEEP - 25T
64	WT296-11	C4AZ7B340C	3RD GEAR FORD® CAR 25T - 3.78 O.D. - 1964-73 CLOSE RATIO 2.32 TO 1, NON O.D.
64	2602643	WT296-11A / C4DZ7B340B	3RD GEAR FORD CAR 25T - 3.57 O.D. - 1964-73 WIDE RATIO 2.78 TO 1, NON-O.D.
64	2603884	T170-11B / D7DZ7B340A	4TH GEAR (O.D.) FORD CAR 21T - 1977-78
64	2603924	T170-11G / D9BZ7B340B	4TH GEAR (O.D.) FORD CAR 20T - 1979-83 8 CYL.
64	2604181	T170-11F / D9BZ7B340A	4TH GEAR (O.D.) FORD CAR 20T - 1979-83 6 CYL.
64	2603744	T170-11D / D8UZ7B340B	4TH GEAR (O.D.) FORD TRUCK 19T - 1978-84 IRON CASE
64	2603737	T170-11C / D8UZ7B340A	4TH GEAR (O.D.) FORD TRUCK 18T - 1978-84 IRON CASE
64	2604242	T170-11J / E0TZ7B340B	4TH GEAR (O.D.) FORD TRUCK 18T - 1980-85 ALUM. CASE
64	2605212	T170-11H / E0TZ7B340A	4TH GEAR (O.D.) FORD TRUCK 20T - 1980-85 ALUM. CASE
65	2604150	T170-21G / 8132382	2ND GEAR JEEP 33T
65	2604252	T170-21H / 8132383	2ND GEAR JEEP 34T
65	2604249	T170-21J / 8132384	2ND GEAR JEEP 32T
65	2603738	T170-21C / D8UZ7102A	2ND GEAR FORD TRUCK 29T - 1978-84 IRON CASE
65	2604232	T170-21F / E0TZ7102A	2ND GEAR FORD TRUCK 29T - 1980-85 ALUM. CASE
65	WT296-21	C4DZ7102D	2ND GEAR FORD CAR 28T - 1964-73 CLOSE RATIO 2.32 TO 1, NON-O.D.
65	2602644	C4DZ7102A / WT296-21A	2ND GEAR FORD CAR 31T - 1964-73 WIDE RATIO 2.78 TO 1, NON-O.D.
65	2603612	T170-21B / D7DZ7102A	2ND GEAR FORD CAR 31T - 1977-78
65	2603894	T170-21E / D9BZ7102A	2ND GEAR FORD CAR 31T - 1979-83
66	WT287-83	T91L-14A/2603658	SYNCHRO RING 1-2-3-4 IRON CASE
66	T170-14A	2605123 / 2605124	SYNCHRO RING 1-2-3-4 ALUM. CASE
67	2605117	WT296-78	SYNCHRO SPRINGS - ALL
68	WT296-81	2605139	SYNCHRO SLEEVE 1-2, M/S REV. GEAR - ALL
70	2602648	T16-13	SYNCHRO KEYS 1-2 - ALL
72	AT170-80A		SYNCHRO ASSY. 1-2 - IRON CASE
72	2670167	AT170-80B	SYNCHRO ASSY. 1-2 - ALUM. CASE
74	2604300	T170-12B / D9BZ7A029B	1ST GEAR - ALL
75	308L		OUTPUT BEARING - JEEP
75	307L		OUTPUT BEARING - FORD CAR
75	308L4		OUTPUT BEARING - FORD TRUCK
81	2604211	8132374 / T170-2L	MAIN SHAFT - JEEP 4X4 11-5/8" O.A. 32-37, 23 SPL.
81	2602692	C8AZ7061B / WT296-2G	MAIN SHAFT - FORD CAR FULL SIZE 27-7/32" 1968-73, 32-37 28 SPL.
81	2603666	D7DZ7061A / T170-2G	MAIN SHAFT - FORD CAR 23-11/32" - 1977-78, 32-37-28 SPL. SPEEDO 5-1/2" BEHIND REAR BRG.
81	2603829	D9BZ7061A / T170-2J	MAIN SHAFT - FORD CAR 23-11/32" - 1979-83, 32-37-28 SPL. SPEEDO 1-1/4" BEHIND REAR BRG.
81	2604483	E0TZ7061C / T170-2K	MAIN SHAFT - FORD TRUCK 23-11/32" - 1980-85, 32-37-28 SPL. SPEEDO 1-1/4" BEHIND REAR BRG 2WD
81	2603719	D8UZ7061A / T170-2H	MAIN SHAFT - FORD TRUCK 23-1/32" - 1978-84, 32-37-28 SPL. SPEEDO 5-1/2" BEHIND REAR BRG 2WD
81	2604466	E1TZ7061C / T170-2M	MAIN SHAFT - FORD TRUCK 19.34", 32-37, 31 SPL. 4X4
81	2603719	D8UZ7061A / T170-2H	MAIN SHAFT - FORD® TRUCK 23-1/32" - 1978-84, 32-37-28 SPL. SPEEDO 5-1/2" BEHIND REAR BRG 2WD
81	2604466	E1TZ7061C / T170-2M	MAIN SHAFT - FORD TRUCK 19.34 O.A. - 32-37-31 SPL. 4X4
81	WT296-2	C4AZ7061F	MAIN SHAFT - FORD CAR 27-7/32" - 1964-67 FULL SIZE 8 CYL. 32-37-28 SPL. - SPEEDO 9-1/4" BEHIND REAR BRG.
81	WT296-2D	C6AZ7061B	MAIN SHAFT - FORD CAR 27-7/32" - 1964-67 FULL SIZE 8 CYL. 32-37-31 SPL. SPEEDO 9-1/4" BEHIND REAR BRG.
81	2670099	C8AZ7061A / WT296-2F	MAIN SHAFT - FORD CAR 27-7/32" - 1968-73 FULL SIZE 8 CYL. 32-37-31 SPL. SPEEDO 5-1/8" BEHIND REAR BRG.
81	2602615	C5ZZ7061C / WT296-2C	MAIN SHAFT - FORD CAR 23-13/16" - 1965-73, 8 CYL. EXC. FULL SIZE, 32-37-28 SPL.
81	WT296-2E	C70Z7061A	MAIN SHAFT - FORD CAR 23-13/16" - 1965-73, 8 CYL. EXC. FULL SIZE, 32-37-31 SPL.
88	2603617	WT170-10B	REV. IDLER GEAR - REAR
89	C407Q		NEEDLE ROLLER - REV. IDLER (44 REQ.)
91	2605066	WT170-10C / 81324021/ D9BZ7D223A / WT296-10	REVERSE IDLER SLIDING GEAR - ALL
93	2602658	WT296-35	REV. IDLER SHAFT
97	QAR33724		NEEDLE ROLLERS - COUNTERSHAFT (42 REQ.)
98	2604151	8132391 / T170-8K	CLUSTER GEAR - JEEP® R33-26-24-15
98	2604251	8132392 / T170-8L	CLUSTER GEAR - JEEP R31/24-23-15
98	2604248	8132393 / T170-8M	CLUSTER GEAR - JEEP R34-27-25-15
98	2603740	T170-8C / D8UZ7113A	CLUSTER GEAR - FORD® TRUCK R32-35-23-15 O.D.
98	2603745	T170-8D / D8UZ7113B	CLUSTER GEAR - FORD TRUCK R31-34-23-15 O.D.

TREMEC® T170 STYLE (cont.)

ILL #	MIDWEST #	REF #	REPLACEMENT PART DESCRIPTION
98	2604234	T170-8H / E0T27113A	CLUSTER GEAR - FORD TRUCK R32-43-23-15 O.D. (CAN USE 2603740 CLUSTER AND 2603737 HEAD GEAR TO UPDATE O.D.)
98	2603243	E0T27113B / T170-8J	CLUSTER GEAR FORD TRUCK R31-35-23-15 O.D.
98	WT296-8	C4AZ7113B	CLUSTER GEAR FORD CAR R25-21-18-15 - 1964-73 CLOSE RATIO 2.32 TO 1 - NON-O.D.
98	2602653	C4DZ7113B / WT296-8A	CLUSTER GEAR FORD CAR R30-24-21-15 - 1964-73 WIDE RATIO 2.78 TO 1 - NON-O.D.
98	2603885	D7DZ7113A / T170-8B	CLUSTER GEAR FORD CAR R37-40-26-15, 1977-78 FORD GRANADA/MONARCH 6 CYL. O.D.
98	2604182	D9BZ7113A / T170-8F	CLUSTER GEAR FORD CAR R37-40-26-15, 1979-83 6 CYL., O.D.
98	2603927	D9BZ7113B / T170-8G	CLUSTER GEAR FORD CAR 436-41/26-15, 1979-83 8 CYL., O.D.

KITS

T170R	→ BEARING KIT - FORD CAR
T174R	→ BEARING KIT - FORD TRUCK
T175R	→ BEARING KIT - JEEP
GS170-55	→ GASKET SET FORD CAR / FORD TRUCK / JEEP
GS173-55	→ GASKET SET
GS296-55	→ GASKET SET - HEH FORD CAR
K170	→ GASKET/SEAL KIT - FORD CAR
K174	→ GASKET/SEAL KIT - FORD TRUCK
K175	→ GASKET/SEAL KIT - JEEP
SP170-50	→ SMALL PARTS KIT - FORD CAR/TRUCK
SP176-50	→ SMALL PARTS KIT - JEEP
SP296-50	→ SMALL PARTS KIT - HEH FORD CAR
T170K1	→ KEY/SPRING KIT 1-2 SYNCHRO
T170K3	→ KEY/SPRING KIT 3-4 SYNCHRO



Motive
Gear®

TK5[®] STYLE

RANGER/BRONCO II - 1983-87, AEROSTAR - 1986-87, (5 SPEED)

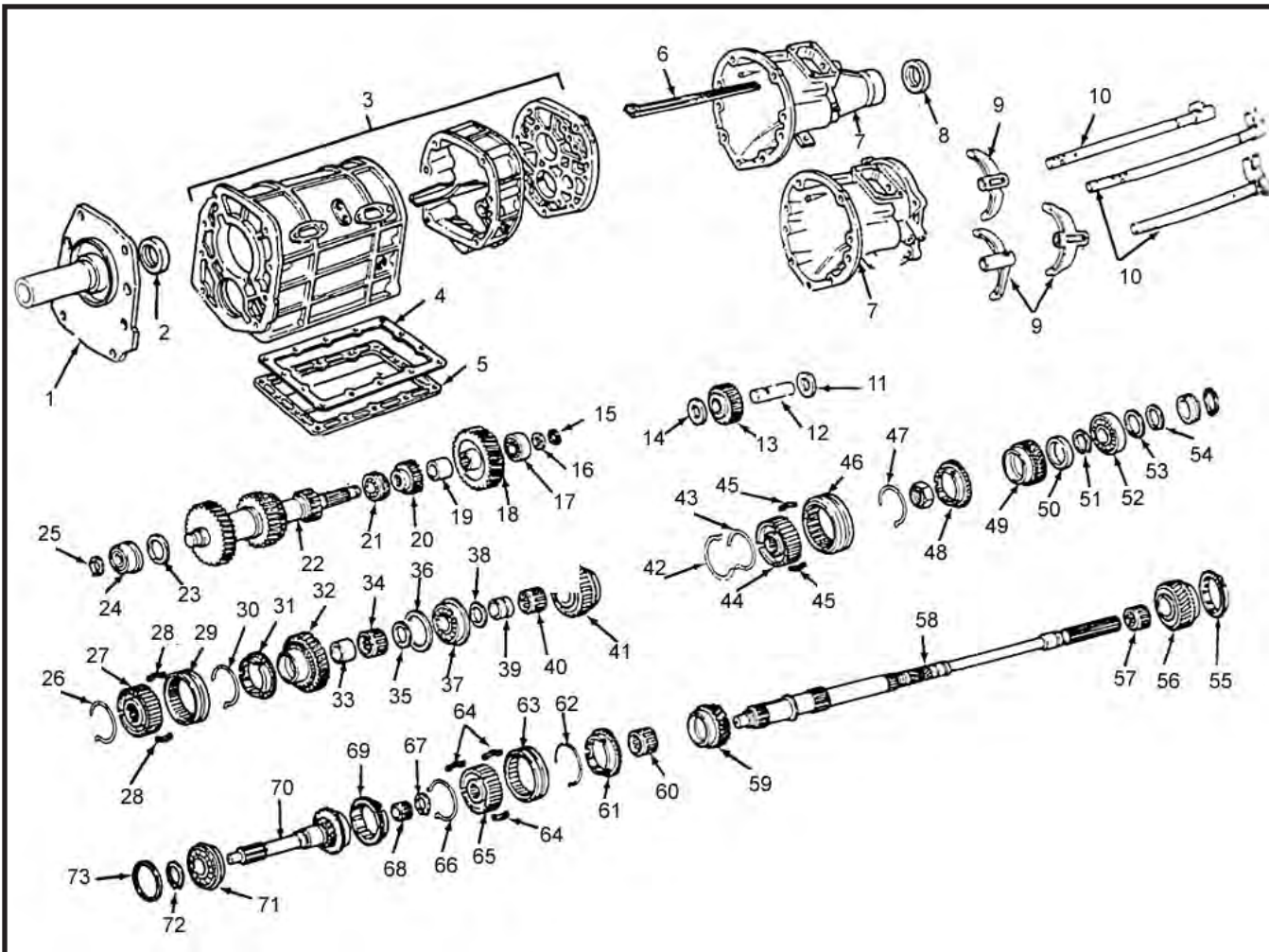

TK5® STYLE (cont.)

ILL #	MIDWEST #	REF #	REPLACEMENT PART DESCRIPTION
1	E3TZ7050A		RETAINER - FRONT BEARING 1983-84 - BRONCO II & RANGER
1	E5TZ7050B		RETAINER - FRONT BEARING 1985-87 (INCLUDING AEROSTAR)
2	1990	D27Z7052A	SEAL - INPUT
3	E7TZ7005A		MAIN CASE - AEROSTAR 1986-87, BRONCO II 1984 - 4WD, V6, E37E-LA, 1985-86 4WD - EDE574-PA, RANGER 1984, 4WD, V6, E37E-LA & 2WD, V6 1985-87 4WD - EDE574-PA
3	E3TZ7005D		MAIN CASE - 1984 BRONCO II, 4WD, V6 - E37A-JE, 1983 RANGER, 1984 4WD, V6, 4 CYL.
3	E69Z7005A		MAIN CASE - 1985 BRONCO II, 4WD - E57A-PA, 1985 RANGER, 2/4WD - 357A-PA
4	D67Z7166A		OIL PAN GASKET - ALL (BOTTOM)
N.I.	D67Z7166B		OIL PAN GASKET - ALL (SIDE)
5	D77Z7165A		OIL PAN, (BOTTOM)
N.I.	D77Z7165B		OIL PAN, ALL (SIDE)
6	E3TZ7A174B		OIL TROUGH
7	E69Z7A039A		EXTENSION HOUSING - 1986-87 AEROSTAR 2WD, 1986 BRONCO II 2WD, 1985-87 RANGER 2WD
7	E3TZ7A039M		EXTENSION HOUSING - 1984 BRONCO II, 4WD, 1983-84 RANGER 4WD
7	E3TZ7A039P		EXTENSION HOUSING - 1983 RANGER 2WD, 1984 RANGER 2WD
7	E6TZ7A039A		EXTENSION HOUSING - 1985-86 BRONCO II 4WD
7	E3TZ7A039K		EXTENSION HOUSING - 1984 RANGER 2WD, V6
8	1623	E3TZ7052C	REAR SEAL, 2WD EARLY 1983-84
8	2655	E5TZ7052B	REAR SEAL, 2WD LATE 1985-87
9	E3TZ7230A		FORK 1-2, 1984 BRONCO II, 1983-85 RANGER
9	E3TZ7230B		FORK 3-4, 1984 BRONCO II, 1983-85 RANGER
9	E3TZ7230D		FORK 5-REV., 1984 BRONCO II, 1983-84 RANGER, 1985 - E37A-JE
9	E69Z7230A		FORK 1-2, 1986 - ALL
9	E7TZ7230A		FORK 1-2, 1987 AEROSTAR AND RANGER
9	E69Z7230C		FORK 3-4, 1986-87 - ALL
9	E5TZ7230E		FORK 5-REV., 1986-87 - ALL
17	63/22XN	D27Z7025B	BEARING, C/S REAR
18	E7TZ7142B		REV. GEAR, C/S
18	D67Z7109A		SPRING, SYNCHRONIZER
19	E0TZ7115B		SPACER, C/S
20	E3TZ7144A		5TH GEAR, C/S
21	K25X58X20	E8TZ7121AA	BEARING, C/S CENTER
22	TK5-8	E3TZ7113F	CLUSTER GEAR, 31-27-22-14
22	E7TZ7113A		CLUSTER GEAR 1986-87
23	D67Z7030A		C/S SPACER, FRONT
24	25BJ05NRNC2	D67Z7025B	BEARING, C/S FRONT
25	D67Z7030A		SNAP RING
25	D67Z7030B		SNAP RING - INPUT 1983-86
25	E7TZ7030A		SNAP RING - INPUT 1987
27	D67Z7124B		SYNCHRO HUB 1-2, 1983-85
27	E7TZ7124A		SYNCHRO HUB 1-2, 1986-87
28	D67Z7173A		SLEEVE, M/S - ALL
28	D69Z7A044A	L5Z7A044BA	KEY, SYNCHRONIZER 1986-87, 1-4
29	D67Z7183A		SYNCHRO SLEEVE - 1984 BRONCO II, 1983-84 RANGER - WILL FIT 1-2 AND 3-4 ASSY
29	E69Z7183A		SYNCHRO SLEEVE - 1986-87 AEROSTAR, 1986 BRONCO II, 1986-87 RANGER - WILL FIT 1-2 AND 3-4 ASSY
29	E5TZ7183A		SYNCHRO SLEEVE - 1985 BRONCO II - WILL FIT 1-2 AND 3-4 ASSY
32	E7TZ7100A		1ST GEAR M/S, 1983-85 BRONCO II, RANGER
32	E69Z7100B		1ST GEAR M/S, 1986-87 - ALL
34	D67Z7059A		RETAINING RING
35	D6TZ7062A		THRUST WASHER, SELECTIVE, 2.5mm THICK
37	63/32RZNA1	E69Z7118A	BEARING, M/S CENTER
37	D67Z7072A		SPACER
37	077Z7119A		THRUST WASHER, SELECTIVE 2.0mm THICK
38	D27Z7030B		C/S SPACER, REAR
38	E3TZ7030B		SNAP RING
41	E6TZ7158A		5TH GEAR M/S, 1983-85 - ALL
41	E69Z7158A		5TH GEAR M/S, 1986 - ALL
41	E69Z7158B		5TH GEAR M/S, 1987 AEROSTAR, RANGER
44	D67Z7124C		SYNCHRO HUB 5-REV. ALL
45	D27Z7A044B		KEY, SYNCHRONIZER 1983-85 ALL, 1986-87 - 5-REV.
46	E5TZ7187A		5TH & REVERSE SLEEVE, 1986-87 AEROSTAR, 1985-87 BRONCO II, RANGER
46	D67Z7187A		5TH & REVERSE SLEEVE, 1983-84 BRONCO II & RANGER

TK5® STYLE (cont.)

ILL #	MIDWEST #	REF #	REPLACEMENT PART DESCRIPTION
48	MAZ-14B	D67Z7107B	SYNCHRO RING 5TH
48	D67Z7030C		SNAP RING
49	D67Z7141A		REVERSE GEAR M/S
50	D67Z7140A		SHAFT, REVERSE IDLER
52	63/28N	E3TZ7065A	BEARING, M/S REAR
56	E3TZ7102B		2ND GEAR M/S, 1983-85 BRONCO II, RANGER
56	E69Z7102A		2ND GEAR M/S, 1986-87 - ALL
58	E7TZ7061A		MAIN SHAFT 1986-87 AEROSTAR, 1986 BRONCO II, 1983-87 RANGER 2WD
58	E6TZ7061D		MAIN SHAFT 1984-86 BRONCO II - E67A-CA, CB, CC, 1983-86
58	E6TZ7061G		MAIN SHAFT 4X4, 1986-87 LATE - E67A-PA
59	E69Z7101A		3RD GEAR, M/S
60	D67Z7121A		NEEDLE BEARING, M/S 3RD
63			SEE ITEM #29
65	D87Z7124A		SYNCHRO HUB 3-4, 1983-85
65	E69Z7124A		SYNCHRO HUB 3-4, 1986-87
67	D27Z7064A		SNAP RING
68	K20/28/20	D6TZ7120A	POCKET BEARING, M/S PILOT
69/61/55/31	MAZ-14C	D67Z7107C	SYNCHRO RING 3-4, 1-2
70	TK5-16	E3TZ7017E	INPUT - 11-1/2" O.A. - 19T - 2" PILOT
70	TK5-16A	E3TZ7017A	INPUT - 10-1/4" O.A. - 19T - 3/4" PILOT
70	TK5-16B	E69Z7017A	INPUT - 10-1/4" O.A. - 19T LATE
71	307L	E69Z7025A	INPUT BEARING - ALL
73	D67Z7029E		SPACER, SELECTIVE, .1mm THICK
73	D27Z4109A		SHIM - INPUT .1mm THICK

KITS

T12R	→ BEARING, GASKET & SEAL KIT
T12RMK	→ BEARING, GASKET, SEALS, AND RING KIT
T12RAMK	→ BEARING, GASKET, SEALS, AND LATE RING KIT
K12	→ GASKET & SEAL KIT

TREMEC® TR3550 / TKO STYLE

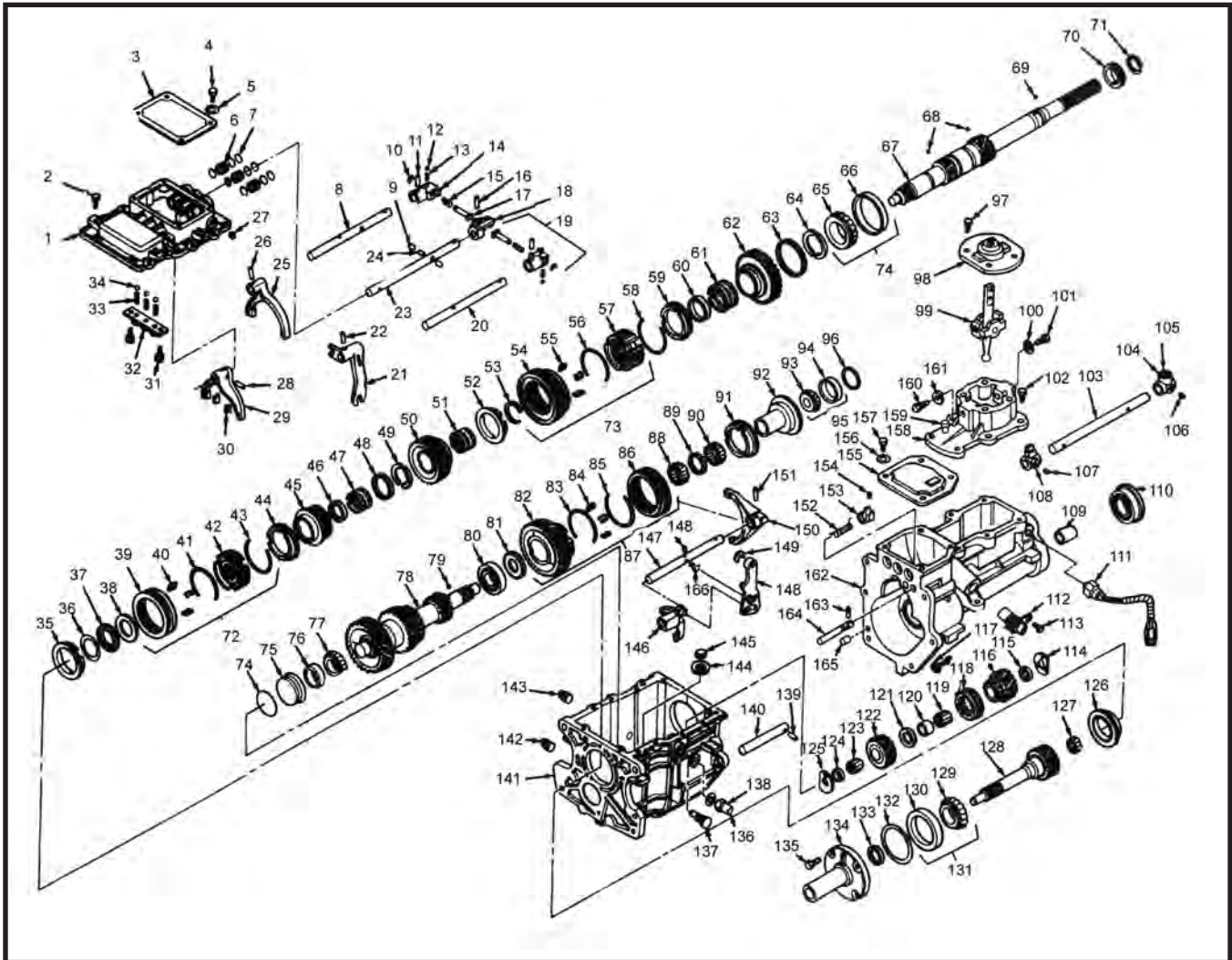

ILL #	MIDWEST #	REF #	REPLACEMENT PART DESCRIPTION
-------	-----------	-------	------------------------------

1	2605803		TOP COVER w/o GUIDE PINS
1	2605802		TOP COVER - GUIDE PINS
1	TCBR-0001		TOP COVER ASSY - LATE DESIGN
2	25603968		BOLT - TOP COVER (10 REQ.)
3	2605866		INSPECTION COVER
4	2604902		BOLTS (4 REQ.)
5	2604899		WASHER (4 REQ.)
6	2605811		GUIDES - SHIFT RAIL (3 REQ.)
7	2605812		O-RING - SHIFT RAIL GUIDES (9 REQ.)
8	2605804		SHIFT RAIL - 1-2 EARLY DESIGN
8	TCBR-0004		SHIFT RAIL - 1-2 LATE DESIGN
9	2604895		SHIFT INTERLOCK PIN (2 REQ.)
10	2605817		E-CLIP SNAP RING (2 REQ.)
11	2604154		SHIFT LUG ROLL PIN (2 REQ.)
12	10J000008		POPPET BALL
13	2606264		SPRING
14	2606212		SHIFT LUG 1-2 AND 5-REV. (2 REQ.)
15	2606263		PISTON SPRING (2 REQ.)
16	14J1822		ROLL PIN - SHIFT LUG ROLL PIN
17	2605815		PISTON (2 REQ.)
18	2606293		SHIFT LUG 3-4
19	2606265		SHIFT LUG ASSY 1-2 AND 5-REV.
20	2605806		SHIFT RAIL - 5-REV. EARLY DESIGN

TREMEC® TR3550 / TKO STYLE (cont.)

ILL #	MIDWEST #	REF #	REPLACEMENT PART DESCRIPTION
20	TCBR-0003		SHIFT RAIL - 5-REV. LATE DESIGN
21	2606214		SHIFT LEVER - 5-REV.
23	2605805		SHIFT RAIL 3-4 EARLY DESIGN
23	TCBR-0002		SHIFT RAIL 3-4 LATE DESIGN
24	2604832		CENTER INTERLOCK PIN
25	2605808		SHIFT FORK 1-2
27	2605083		ALLEN SCREW - INTERLOCK PLUG
28/26/22	2604154		ROLL PIN - SHIFT RAIL (3 REQ.)
29	2605996		SHIFT FORK 3-4
30	2605922		FORK PADS
31	2605829		BOLT - INTERLOCK BRACKET (2 REQ.)
32	2605810		BRACKET - INTERLOCK SPRING
33	2601082		INTERLOCK SPRING (3 REQ.)
34	10J000012		POPPET BALL (3 REQ.)
36	2705766		THRUST WASHER/RACE
37	FA35688	235382	THRUST BEARING
38	2905767		THRUST WASHER/RACE
39	2605764		SYNCHRO SLEEVE 3-4
42	2606083		SYNCHRO HUB 3-4
45	2606262		3RD GEAR
46	2606081		SPACER - 3RD GEAR - EARLY DESIGN
46	2606339		SNAP RING - 3RD GEAR - LATE DESIGN
48	2606077		RETAINER - THRUST WASHER
49	2606076		SPLIT RING THRUST WASHER
50	2606074		2ND GEAR
51/47	F93934	2606075	ROLLER BEARING ASSY
51/91/52/ 44/35	T170-14A	2605124	SYNCHRO RING - 1-2-3-4 AND 5TH
53	2602650		SNAP RING
54	2606073		SYNCHRO SLEEVE 1-2/REV.
55	2602648		SYNCHRO KEYS 1-2 (3 REQ.)
57	2606072		SYNCHRO HUB
60	2606110		SPACER - 1ST GEAR - EARLY DESIGN
60	2602650		SNAP RING - 1ST GEAR - LATE DESIGN
61	FC662662	2606109	ROLLER BEARING
62	2606070		1ST GEAR
63	2605708		RETAINER - THRUST WASHER
64	2605707		SPLIT RING THRUST WASHER
65	2605706		M/S BEARING CONE
66	2605701		M/S BEARING CUP
67	2606242		MAIN SHAFT - STANDARD 28 SPL.
67	2606413		MAIN SHAFT - TKO 31 SPL.
69	10J000006		STEEL BALL
70	2601215		SPEEDOMETER DRIVE GEAR
71	2604502		SNAP RING
72/43	2606082		SYNCHRO ASSY 3-4
73	2670739		SYNCHRO ASSY - REV. GEAR 1-2
73A	2605700		M/S BEARING ASSY
74	2606258		O-RING
75	2606288		CASE PLUG
78	2606261		COUNTERSHAFT - 1 PC. - EARLY DESIGN
78	2606225		COUNTERSHAFT - INTEGRAL 1ST AND 2ND GEAR - LATE DESIGN
78	2602232		DRIVE GEAR - COUNTERSHAFT - LATE DESIGN
78	2606233		3RD GEAR - COUNTERSHAFT - LATE DESIGN
78	5J001008		WOODRUFF KEYS - COUNTERSHAFT - LATE DESIGN
78	2602645		SNAP RING - COUNTERSHAFT - LATE DESIGN
79/68	10J000006		STEEL BALL (2 REQ.)
81	2606118		THRUST WASHER
82	2606089		5TH GEAR - COUNTERSHAFT - SYNCHRO HUB
84/40	2604372		SYNCHRO KEYS 3-4 (3 REQ.)
85/83/58/41	2605117		SYNCHRO SPRING 3-4 (2 REQ.)
86	2605780		SYNCHRO SLEEVE - 5TH GEAR
87	2606088		SYNCHRO ASSY - 5TH GEAR
89	2606092		SPACER - NEEDLE BEARINGS
90/88	2602661		NEEDLE BEARINGS (86 REQ.)
92	2606091		SYNCHRO CONE - 5TH GEAR
93/77	2605788		COUNTERSHAFT BEARING CONE

TREMEC® TR3550 / TKO STYLE (cont.)

ILL #	MIDWEST #	REF #	REPLACEMENT PART DESCRIPTION
94/76	2605787		COUNTERSHAFT BEARING CUP
95/77A	2605786		COUNTERSHAFT BEARING ASSY
96	2605789		SHIM - COUNTERSHAFT REAR BEARING
97	2604025		DUST COVER BOLTS (4 REQ.)
98	2606240		DUST COVER
99	2606237		SHIFT LEVER ASSY - LONG THROW
99	2670945		SHIFT LEVER ASSY - SHORT THROW (HP & TKO)
102	2603968		BOLT - TURRET ASSY (6 REQ.)
103	2606247		SHIFT LINK - EARLY DESIGN
103	2606464		SHIFT LINK - LATE DESIGN
104	7606247		SHIFT LEVER SOCKET - EARLY DESIGN
104	2606463		SHIFT LEVER SOCKET - LATE DESIGN
105	2606246		SHIFT LEVER SOCKET BUSHING
106	2601227		ALLEN SCREW - SHIFT LEVER SOCKET - EARLY DESIGN
106	1411822		ALLEN SCREW - SHIFT LEVER SOCKET - LATE DESIGN
107	2601227		ALLEN SCREW - SELECT FINGER - EARLY DESIGN
107	1411822		ALLEN SCREW - SELECT FINGER - LATE DESIGN
108	2605855		SELECT FINGER
109	2603891		BUSHING - EXTENSION HOUSING - STANDARD
109	2606417		BUSHING - EXTENSION HOUSING - TKO
110	7692S	2603979	OUTPUT SEAL - STANDARD
110	2606416		OUTPUT SEAL - TKO
111	2606244		SWITCH - NEUTRAL SAFETY
112	17271T		SPEEDOMETER DRIVEN GEAR
113	99796-0616		SCREW - SPEEDOMETER CABLE RETAINER
116	2606093		REVERSE IDLER GEAR
117	5E000007		WASHER (6 REQ.)
118	2605800		REVERSE SELECTOR SLEEVE
120	2605798		SPACER - ROLLER BEARING - EARLY DESIGN
120	2606466		SPACER - ROLLER BEARING - LATE DESIGN
121	2605795		THRUST WASHER
122	2606094		REVERSE GEAR
123/119	C407Q	2602661	NEEDLE BEARING - REV. IDLER - LATE DESIGN (44 REQ.) (USE 22-2605797)
123/119	2605797		NEEDLE BEARING - REV. IDLER - EARLY DESIGN (44 REQ.)
123/119	2605797		NEEDLE BEARING - REV. IDLER - LATE DESIGN (22 REQ.)
124/115	2606465		SPACER - ROLLER BEARING - LATE DESIGN (3 REQ.)
124/115	2605799		SPACER - ROLLER BEARING - EARLY DESIGN (2 REQ.)
125/114	2603695		THRUST WASHER - REVERSE IDLER (2 REQ.)
126	2605768		SYNCHRO CONE - INPUT SHAFT
127	QBR 23549	2601210	NEEDLE BEARING - INPUT POCKET (17 REQ.)
128	2606241		INPUT SHAFT - STANDARD 10 SPL.
128	2606412		INPUT SHAFT - TKO 26 SPL.
129	2606065		INPUT BEARING CONE
130	2605686		INPUT BEARING CUP
131	2606064		INPUT BEARING ASSY
132	2606066-069		SHIM - INPUT BEARING
133	2603865		SEAL - INPUT SHAFT
134	2606243		FRONT BEARING RETAINER
135	2603698		BOLTS - FRONT RETAINER (4 REQ.)
136	2606249		SWITCH - BACKUP LIGHTS
137	2604720		PIVOT PIN
138	2605032		GASKET - BACKUP LAMP SWITCH
139	1412524		LOCKING PIN - REVERSE SHAFT
140	2605793		REVERSE SHAFT
141	2606106		MAIN CASE - MAGNET
142	13F000008		DRAIN PLUG
143	13F000008		FILL PLUG
144	2602631		MAGNET (N.S.S.)
145	2603939		MAGNET RETAINER (N.S.S.)
145	1C000728		BOLT - EXTENSION HOUSING (6 REQ.)
146	2606216		FORK - REVERSE
147	2605823		RAIL - 5-REV. SHIFT
148	2605948		LEVER 5-REV.
148A	2604342		ROLL PIN 5-REV. ACTUATING PIN
149	2603965		WAVE E-CLIP
150	2606111		SHIFT FORK - 5TH FORK
151	2604154		ROLL PIN - 5TH FORK
152	2605832		SPRING REVERSE LOCK-OUT
153	2606259		REVERSE LOCK-OUT

TREMEC® TR3550 / TKO STYLE (cont.)

ILL #	MIDWEST #	REF #	REPLACEMENT PART DESCRIPTION
154	2603897		ROLL PIN
155	2606248		EXTENSION COVER
156	2604899		WASHER (4 REQ.)
157	2604902		BOLT (4 REQ.)
158	2671061		SHIFT TURRET ASSY
159	2124715		BREATHER
160/101	2605984		LATERAL SUPPORT PIVOT (2 REQ.)
161/100	2605949		LOCKING TAB WASHER (2 REQ.)
162	2606223		EXTENSION HOUSING ASSY
162	2606414		EXTENSION HOUSING ASSY - TKO - BUSHING
162	2606415		EXTENSION HOUSING - TKO w/o BUSHING
163	6501095		ALLEN SCREW - REV. - LOCK-OUT SHAFT
164	2606095		REVERSE LOCK-OUT SHAFT
165	2604636		ALIGNMENT DOWEL (EXT. HOUSING TO CASE)
166	2605824		ACTUATING PIN - 5-REV.

KITS

T3550R	→	BEARING KIT
T3550RMK	→	MASTER BEARING KIT
2671136	→	FRONT SHIFT CONVERSION KIT
2671127	→	MID-SHIFT CONVERSION KIT
M6392R58	→	BELL HOUSING - FORD® MUSTANG APPLICATION - ALUM.
M6392C	→	SCATTERSHIELD 1979-93 MUSTANG APPLIC. - STEEL
M5059A	→	ADJUSTABLE CROSS MEMBER 1979-93 MUSTANG
8625	→	MCLEOD BELLHOUSING 289, 302, 351 - TREMEC 3550 ADAPT.
8655	→	MCLEOD BELLHOUSING SB CHEVY, BUICK®, OLDSMOBILE®, PONTIAC® V8 - 1962-92 - TREMEC 3550 ADAPTER (NO HYD. SLAVE CYL. BRACKET)
8610	→	MCLEOD ADAPTER TREMEC 3550 TRANS TO 17 DEGREES, T-5 BELLHOUSING
8607	→	MCLEOD ADAPTER TREMEC 3550 TO STANDARD CHEVY BELLHOUSING
5055	→	PRO 5.0 SHORT THROW SHIFTER - 3550 ADAPTER
RK3550	→	SYNCHRO RING KIT



**Motive
Gear®**

TREMEC® TR3650 STYLE

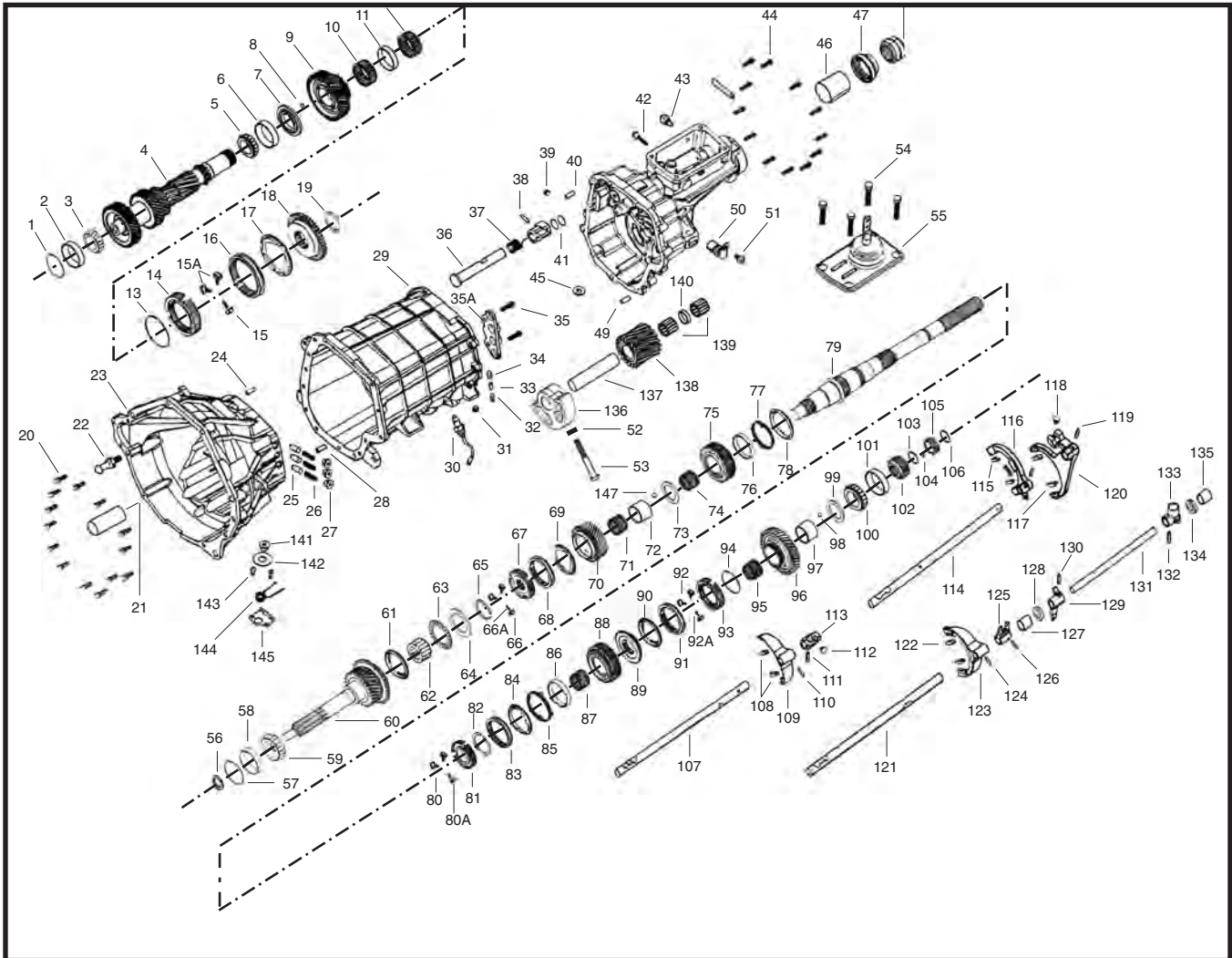

ILL #	MIDWEST #	REF #	REPLACEMENT PART DESCRIPTION
1	TCMS0695, 96, 97, 98		COUNTERSHAFT BEARING SHIMS
2	TCBA0700		COUNTERSHAFT BEARING CUP, FRONT
3	TCBA0767		COUNTERSHAFT CONE BEARING, FRONT
4	TCCF1848		COUNTERSHAFT CLUSTER GEAR (TCET1265, 1789)
4	TCCF1848		COUNTERSHAFT CLUSTER GEAR (TCET1858, 1903, 1925, 1986)
5	TCBA0778		COUNTERSHAFT CONE BEARING, REAR
6	TCBA0777		COUNTERSHAFT BEARING CUP / RACE, REAR
7	TCRA1433		COUNTERSHAFT 5TH GEAR, THRUST WASHER
8	10J0006		BALL (1 REQ.)
9	TCEN1650		COUNTERSHAFT 5TH GEAR (USED w/TAG# TCET1265, 1858)
9	TCEN1785		COUNTERSHAFT 5TH GEAR(USED w/TAG# TCET1789, 1903,1925)
9	TCEN1381		COUNTERSHAFT 5TH GEAR (USE w/TAG# TCET 1986)
10	TCBA0715		COUNTERSHAFT 5TH GEAR ROLLER BEARING
11	TCSP0781		COUNTERSHAFT 5TH GEAR ROLLER BEARING SPACER
12	TCBA0715		COUNTERSHAFT 5TH GEAR ROLLER BEARING
13,14,	TCES1285		COUNTERSHAFT 5TH GEAR SYNCHRO ASSY (USED w/TAG# TCET1265, 1858)
15,16	TCES1786		COUNTERSHAFT 5TH GEAR SYNCHRO ASSY (USEDw/TAG# CET1789,1903,1925)
	TCES2012		COUNTERSHAFT 5TH GEAR SYNCHRO ASSY (USED w/TAG# TCET1986)
13	TCMS0686		COUNTERSHAFT 5TH GEAR SYNCHRO SNAP RING
14	TCMZ1535		COUNTERSHAFT 5TH GEAR SYNCHRO HUB
15	TCNS1438		COUNTERSHAFT 5TH GEAR SYNCHRO KEYS (3 REQ.)
15A	TCRE0664		COUNTERSHAFT 5TH GEAR SYNCHRO KEY SPRINGS (3 REQ.)
16	TCCL1287		COUNTERSHAFT 5TH GEAR SYNCHRO SLIDER
17	TCAS1289		COUNTERSHAFT 5TH GEAR SYNCHRO RING

TREMEC TR3650 STYLE (cont.)

ILL #	MIDWEST #	REF #	REPLACEMENT PART DESCRIPTION
18	TCCN1323		COUNTERSHAFT 5TH GEAR CLUTCH CONE
19	TCMS1382, 83, 84, 85		COUNTERSHAFT SNAP RING (1382 = 2.4MM, 1383 = 2.5MM, 1384 = 2.6MM, 1385 = 2.3MM)
20	1386183004		BELL HOUSING BOLTS (14 REQ.)
21	1381034001		BELL HOUSING TUBE RETAINER
22	1381146001		BELL HOUSING CLUTCH RELEASE LEVER STUD
23	TCEP1268		BELL HOUSING ASSY (USED w/TAG# TCET1265, 1789, 1903, 1925, 1986)
23	TCEP1859		BELL HOUSING ASSY (USED w/ TCET1858)
24	1381043001		BELL HOUSING DOWEL PIN
25	T CSP1305		BELL HOUSING DETENT (3 REQ.)
26	TCRE1306		BELL HOUSING DETENT SPRING (3 REQ.)
27	TCTA1304		BELL HOUSING DETENT PLUG (3 REQ.)
28	1381043001		MAIN CASE DOWEL PIN
29	TCEP1270		MAIN CASE ASSY
30	TCEM1728		MAIN CASE BACKUP LAMP SWITCH ASSY
31	1300052007		MAIN CASE FILLER PLUG
32	2604895		INTERLOCK SHIFTER
33	2604832		INTERLOCK CENTER PIN
34	2604895		INTERLOCK SHIFTER
35	TCTN0613		INTERLOCK SUPPORT BOLTS (2 REQ.)
35A	TCPT1427		INTERLOCK SUPPORT
36	TCBR1404		REVERSE INHIBITOR RAIL
37	2605156		REVERSE INHIBITOR SPRING
38	1332043004		REVERSE INHIBITOR ROLL PIN
38A	TCTP1633		REVERSE INHIBITOR
39	1300052007		TAIL HOUSING DRAIN PLUG
40	1381043001		TAIL HOUSING DOWEL PIN
41	TCSJ0725		REVERSE INHIBITOR O-RINGS (2 REQ.)
42	TCTN1407		TAIL HOUSING PIN INHIBITOR RETAINER BAR
43	2124715		TAIL HOUSING BREATHER
44	TCTN0614		TAIL HOUSING BOLTS (12 REQ.)
45	4915		TAIL HOUSING MAGNET
46	1381127002		TAIL HOUSING BUSHING
47	NV3515383		TAIL HOUSING SEAL
48	1386016002		TAIL HOUSING SEAL OUTPUT SPLINE
49	1381043001		TAIL HOUSING DOWEL PIN
50	4400640019		TAIL HOUSING SPEEDO SENSOR (ALL EXCEPT TAG# TCET1858)
51	1300183038		TAIL HOUSING SPEEDO SENSOR HEX HEAD SCREW
52	TCSJ1437		O-RING
53	TCTN1653		BOLT
54	1351183001		BOLT (4 REQ.) (ALL EXCEPT TAG# TCET1858)
54	TCTN1857		BOLT (4 REQ.) (USED w/TAG# TCET1858)
55	TCEC1310		TAIL HOUSING SHIFT LEVER ASSY
56	74125		TUBE RETAINER OIL SEAL
57	1386037005		BEARING SHIM (.55MM) AS REQUIRED
57	1386037006		BEARING SHIM (.61MM) AS REQUIRED
57	1386037007		BEARING SHIM (.66MM) AS REQUIRED
57	1386037008		BEARING SHIM (.71MM) AS REQUIRED
57	1386037009		BEARING SHIM (.76MM) AS REQUIRED
57	1386037012		BEARING SHIM (.86MM) AS REQUIRED
57	1386037016		BEARING SHIM (.96MM) AS REQUIRED
57	1386037019		BEARING SHIM (1.04MM) AS REQUIRED
58	1300133005		INPUT GEAR BEARING CUP/RACE
59	1300133006		INPUT GEAR TAPERED ROLLER BEARING
60	TCFM1279		INPUT GEAR
61	TCAS1289		INPUT GEAR SYNCHRO RING - 3RD/4TH
62	TCBA0653		INPUT GEAR POCKET BEARING
63	TCBA0655		INPUT GEAR THRUST BEARING
64	TCRA0656		INPUT GEAR THRUST WASHER
65	TCMS0658		SNAP RING (2.3MM) AS REQUIRED
65	TCMS0659		SNAP RING (2.4MM) AS REQUIRED
65	TCMS0660		SNAP RING (2.5MM) AS REQUIRED
65	TCMS0661		SNAP RING (2.6MM) AS REQUIRED
66, 66A	TCE51315		MAINSHAFT 3RD/4TH GEAR SYNCHRO ASSY
67, 68			
66	TCNS1438		MAINSHAFT 3RD/4TH GEAR SYNCHRO KEYS (3 REQ.)
66A	TCRE0664		MAINSHAFT 3RD/4TH GEAR SYNCHRO KEY SPRINGS (3 REQ.)
67	TCMZ1534		MAINSHAFT 3RD/4TH GEAR SYNCHRO HUB
68	TCCL1316		MAINSHAFT 3RD/4TH GEAR SYNCHRO SLIDER

TREMEC TR3650 STYLE (cont.)

ILL #	MIDWEST #	REF #	REPLACEMENT PART DESCRIPTION
69	TCAS1289		MAINSHAFT 3RD/4TH GEAR SYNCHRO RING
70	TCEE1462		MAINSHAFT 3RD GEAR ASSY (GEAR AND CLUTCH CONE)
71	1300132009		MAINSHAFT 3RD GEAR NEEDLE BEARING ASSY
72	TCSP1249		MAINSHAFT 3RD GEAR BUSHING
73	TCRA1314		MAINSHAFT 3RD GEAR THRUST WASHER
74	1300132009		MAINSHAFT 2ND GEAR NEEDLE BEARING ASSY
75	TCEE1282		MAINSHAFT 2ND GEAR ASSEMBLY (GEAR AND CLUTCH CONE)
76	TCAS0673		MAINSHAFT 1ST/2ND GEAR INNER SYNCHRO RING
77	TCAS0674		MAINSHAFT 1ST/2ND GEAR MIDDLE SYNCHRO RING w/FRICTION LINING
78	TCAS0675		MAINSHAFT 1ST/2ND GEAR OUTER SYNCHRO RING
79	TCFP1275		MAINSHAFT (USED w/TAG# TCET1265, 1789, 1903, 1925, 1986)
79	TCFP1869		MAINSHAFT (USED w/TAG# TCET1858)
80, 80A, 81	TCE1317		MAINSHAFT 1ST/2ND GEAR SYNCHRO ASSY
82, 83			
80	TCNS1438		MAINSHAFT 1ST/2ND GEAR SYNCHRO KEYS (3 REQ.)
80A	TCRE0664		MAINSHAFT 1ST/2ND GEAR SYNCHRO KEY SPRINGS (3 REQ.)
81	TCMZ1533		MAINSHAFT 1ST/2ND GEAR SYNCHRO HUB
82	TCMS0679		MAINSHAFT 1ST/2ND GEAR SYNCHRO HUB SNAP RING
83	TCCL1319		MAINSHAFT 1ST/2ND GEAR SYNCHRO SLIDER
84	TCAS0675		MAINSHAFT 1ST/2ND GEAR OUTER SYNCHRO RING
85	TCAS0674		MAINSHAFT 1ST/2ND GEAR MIDDLE SYNCHRO RING w/FRICTION LINING
86	TCAS0673		MAINSHAFT 1ST/2ND GEAR INNER SYNCHRO RING
87	1300132009		MAINSHAFT 1ST GEAR NEEDLE BEARING ASSY
88	TCEE1088		MAINSHAFT 1ST GEAR ASSY (GEAR AND CLUTCH CONE) (USED w/TAG# TCET1265, 1789)
88	TCEE1846		MAINSHAFT 1ST GEAR ASSY (GEAR AND CLUTCH CONE) (USED w/TAG# TCET1858, 1903)
89	TCCN1322		REVERSE CLUTCH CONE
90	TCAS1289		MAINSHAFT REV. GEAR SYNCHRO RING
91, 92,	TCE1300		MAINSHAFT REV. GEAR SYNCHRO ASSY
92A, 93, 94	TCE1882		MAINSHAFT REV. GEAR SYNCHRO ASSY
91	TCCL1287		MAINSHAFT REV. GEAR SYNCHRO SLIDER
92	TCNS1438		MAINSHAFT REV. GEAR SYNCHRO KEYS (3 REQ.)
92A	TCRE0664		MAINSHAFT REV. GEAR SYNCHRO KEY SPRINGS (3 REQ.)
93	TCMZ1534		MAINSHAFT REV. GEAR SYNCHRO HUB
94	TCMS0686		MAINSHAFT REV. GEAR SYNCHRO HUB SNAP RING
95	1300132009		MAINSHAFT REV. GEAR NEEDLE BEARING ASSY
96	TCEN1432		MAINSHAFT REV. GEAR (USED w/TAG# TCET1265, 1789)
96	TCEC1849		MAINSHAFT REV. GEAR (USED w/TAG# TCET1858, 1903, 1925, 1986)
97	TCSP1249		MAINSHAFT REV. GEAR BUSHING
98	10J00006		BALL (1 REQ.)
99	TCRA1314		MAINSHAFT REV. GEAR THRUST WASHER
100, 101	TCBA1765		MAINSHAFT CUP/CONE BEARING ASSY - REAR
100	TCBA1897		MAINSHAFT CONE BEARING - REAR
101	TCBA1896		MAINSHAFT BEARING CUP/RACE - REAR
102	TCEN1651		MAINSHAFT 5TH GEAR (USED w/TAG# TCET1265, 1868)
102	TCEN1787		MAINSHAFT 5TH GEAR (USED w/TAG# TCET1789, 1903, 1925)
102	TCEN2011		MAINSHAFT 5TH GEAR (USED w/TAG# TCET1986)
103	1386139001		MAINSHAFT 5TH GEAR SNAP RING
104	10J000008		SPEEDO GEAR BALL
105	TCEV1276		SPEEDO GEAR (ALL EXCEPT TAG# TCET1858)
106	26004502		SPEEDO GEAR SNAP RING
107	TCBR1290		SHIFT RAIL - 1ST/2ND
108, 109	TCEC1297		SHIFT FORK - 1ST/2ND ASSY
108	1386235001		SHIFT FORK - 1ST/2ND PADS (2 REQ.)
109	TCHR1298		SHIFT FORK - 1ST/2ND (MINUS PADS)
110	1000043016		SHIFT FORK - 1ST/2ND ROLL PIN
111	1000043016		GATE - 1ST/2ND ROLL PIN
112, 113	TCEC1295		GATE - 1ST/2ND ASSY
112	TCNS0627		GATE - 1ST/2ND NYLON STOP
113	TCTP1296		GATE - 1ST/2ND
114	TCBR1292		SHIFT RAIL - 5TH/REV.
115, 116	TCEC1307		SHIFT FORK REVERSE ASSY
115	1386235001		SHIFT FORK REVERSE PADS (3 REQ.)
116	TCHR1308		SHIFT FORK REVERSE (MINUS PADS)
N.I.	1000043016		SHIFT FORK REVERSE ROLL PIN
117	1386235001		SHIFT FORK - 5TH PADS (2 REQ.)
118	TCNS0627		SHIFT FORK - 5TH NYLON STOP
119	1000043016		SHIFT FORK - 5TH ROLL PIN

TREMEC TR3650 STYLE (cont.)

ILL #	MIDWEST #	REF #	REPLACEMENT PART DESCRIPTION
120	TCHR1294		SHIFT FORK - 5TH
121	TCBR1291		SHIFT RAIL - 3RD/4TH
122, 123	TCEC1299		SHIFT FORK - 3RD/4TH ASSY
122	1386235001		SHIFT FORK - 3RD/4TH PADS (2 REQ.)
123	TCHR1300		SHIFT FORK - 3RD/4TH (MINUS PADS)
124	1000043016		SHIFT FORK - 3RD/4TH ROLL PIN
125	TCTP1309		GATE - 3RD/4TH
126	1000043016		GATE - 3RD/4TH ROLL PIN
127	2605858		SELECTOR ARM ROLLER BEARING
128	TCSP12311		SELECTOR ARM SPACER
129	TCTP1302		SELECTOR ARM
130	1000043016		SELECTOR ARM ROLL PIN
131	TCBR1301		SELECTOR RAIL (ALL EXCEPT TAG# TCET1858)
131	TCBR1866		SELECTOR RAIL (USED w/TAG# TCET1858)
132	1000043016		SEAT SELECTOR GATE ROLL PIN
133	TCTP1303		SEAT SELECTOR GATE
134	TCSP12311		SEAT SELECTOR GATE SPACER
135	2605858		SEAT SELECTOR GATE ROLLER BEARING
136	TCPT1436		REVERSE SHAFT SUPPORT
137	TCBR1434		REVERSE SHAFT RAIL
138	TCEN0784		REV. IDLER GEAR (USED w/TAG# TCET1265, 1789)
138	TCEN1850		REV. IDLER GEAR (USED w/TAG# TCET1858, 1903, 1925, 1986)
139	TCBA0721		REV. IDLER GEAR ROLLER BEARING (2 REQ.)
140	TCSP0722		REV. IDLER GEAR ROLLER BEARING SPACER
141	TCTA1304		DETENT PLUG
142	TCRA1429		SPRING WASHER
143	1386183002		BOLT (2 REQ.)
144	1386156014		SPRING CENTERING SHIFT CONTROL
145	TCPA1403		SPRING BASE TURRET
147	10J00006		BALL (1 REQ.)
N.I.	1000043016		SHIFT FORK REVERSE ROLL PIN

KITS

T255R	→ BEARING & SEAL KIT
T255RMK	→ MASTER BEARING, SEAL & GASKET KIT w/RINGS

ZF PARKING BRAKE STYLE

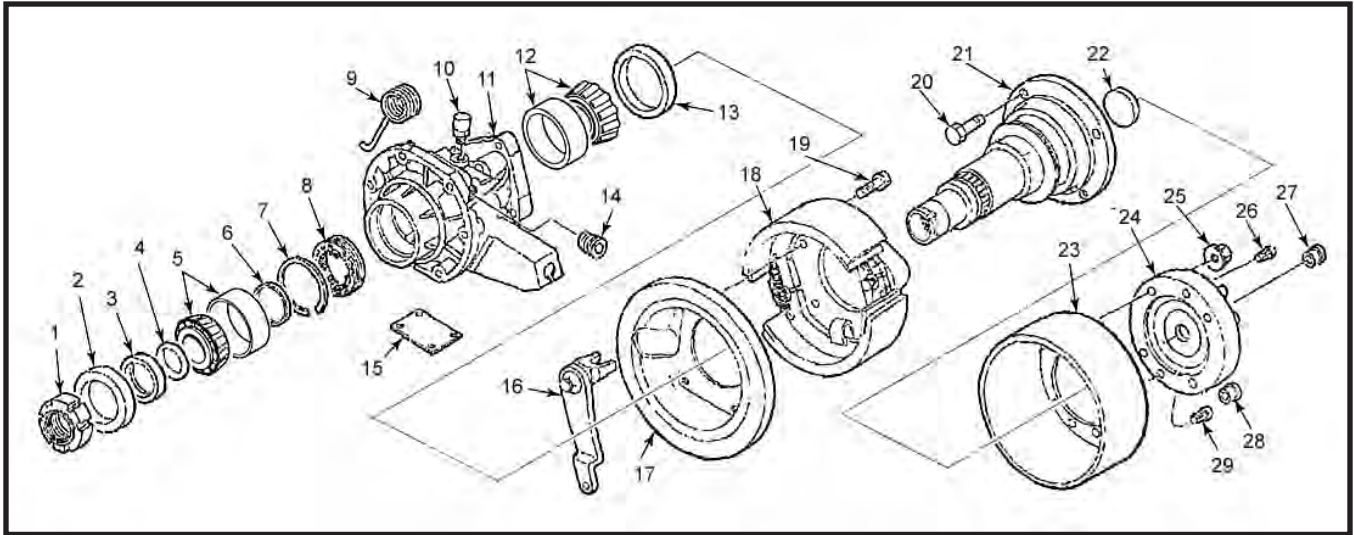

ILL #	MIDWEST #	REF #	REPLACEMENT PART DESCRIPTION
1	E8T22L616A		NUT
2	E8T22L607A		SEAL, OIL (SMALL)
3	E8T22L601A		BUSHING
4	AS72-88B	E7TZ7288B	O-RING
5	JLM704610		BEARING RACE
5	JLM704649		BEARING
6	E8T22L613A		WASHER
7	E8T22R598A		SNAP RING - SPEEDO
8	ZFBD-169	E8T22N598A	SPEEDO GEAR - GREEN
9	E8T22M598A		SPRING, LEVER
10	E8T22L605A		FITTING, BREATHER
11	ZFBD-164	E8T22K598A	HOUSING - SPEEDO HOLE
12	JLM508710		BEARING RACE
12	JLM508748		BEARING
13	E8T22L606A		SEAL, OIL (BIG)
14	E7TZ7A010C		PLUG, FILL
15	N/A		I.D. TAG
16	E8T22A710A		LEVER, BRAKE ACTIVATING
17	E8T22A703A		SHIELD, DUST
18	2086	F3TZ2K598A	SHOE/LINING
19	E8T22L618A		SCREW, LOCK
21	ZFBD-175		BRAKE DRUM SHAFT (9" SHAFT - ACCEPTS SPEEDO GEAR)
20	E8T22L617A		HEX SCREW
22			PLUG - SPINDLE
23	E8T22C598B		BRAKE DRUM & YOKE ASSY
24			FLANGE, END YOKE
25	E8T22L611A		LOCK NUT
26/29	E8T22L614A		STUD
27/28	E8T22L610A		PLUG

KITS

T300BDR	➔ BEARING & SEAL KIT
6051001035	➔ ELECTRIC SPEEDO / NO HOLE
6051001036	➔ MECHANICAL SPEEDO - HOLE

HONDA® A2Q6 STYLE

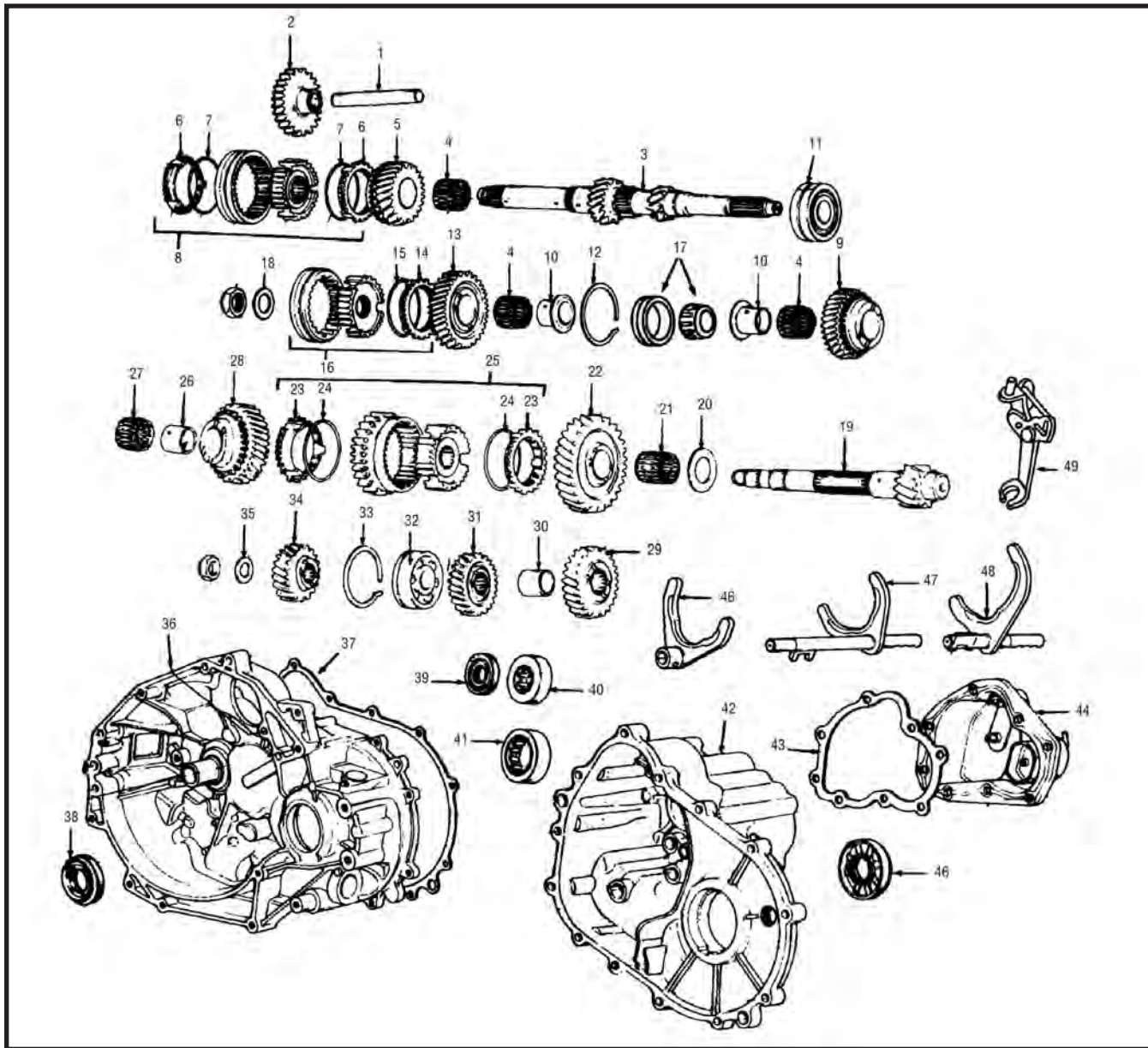

ILL #	MIDWEST #	REF #	REPLACEMENT PART DESCRIPTION
13/34	HON-5		KIT - 5TH GEAR SET - 36T/25T
16	HON-40		SYNCHRO ASSY - 5TH
23	HON-14		SYNCHRO RING 1-2, 36T, 2.97" O.D.
6	HON-14A		SYNCHRO RING 3-4, 30T, 2.5" O.D.
14	HON-14B		SYNCHRO RING 5TH, 21T, 2.27" O.D.
14	HON-14C		SYNCHRO RING, 33T, 2.21" O.D.
14	HON-14D		SYNCHRO RING, 27T, 2.74" O.D.

KITS

T238R → BEARING, GASKET & SEAL KIT - 8 BOLT COVER, 5TH GEAR

MSG-5ET, MSG-5F STYLE ISUZU® 4x4 TRUCK (MSG-5ET: 84-87), (MSG-5F: 6/87-ON)

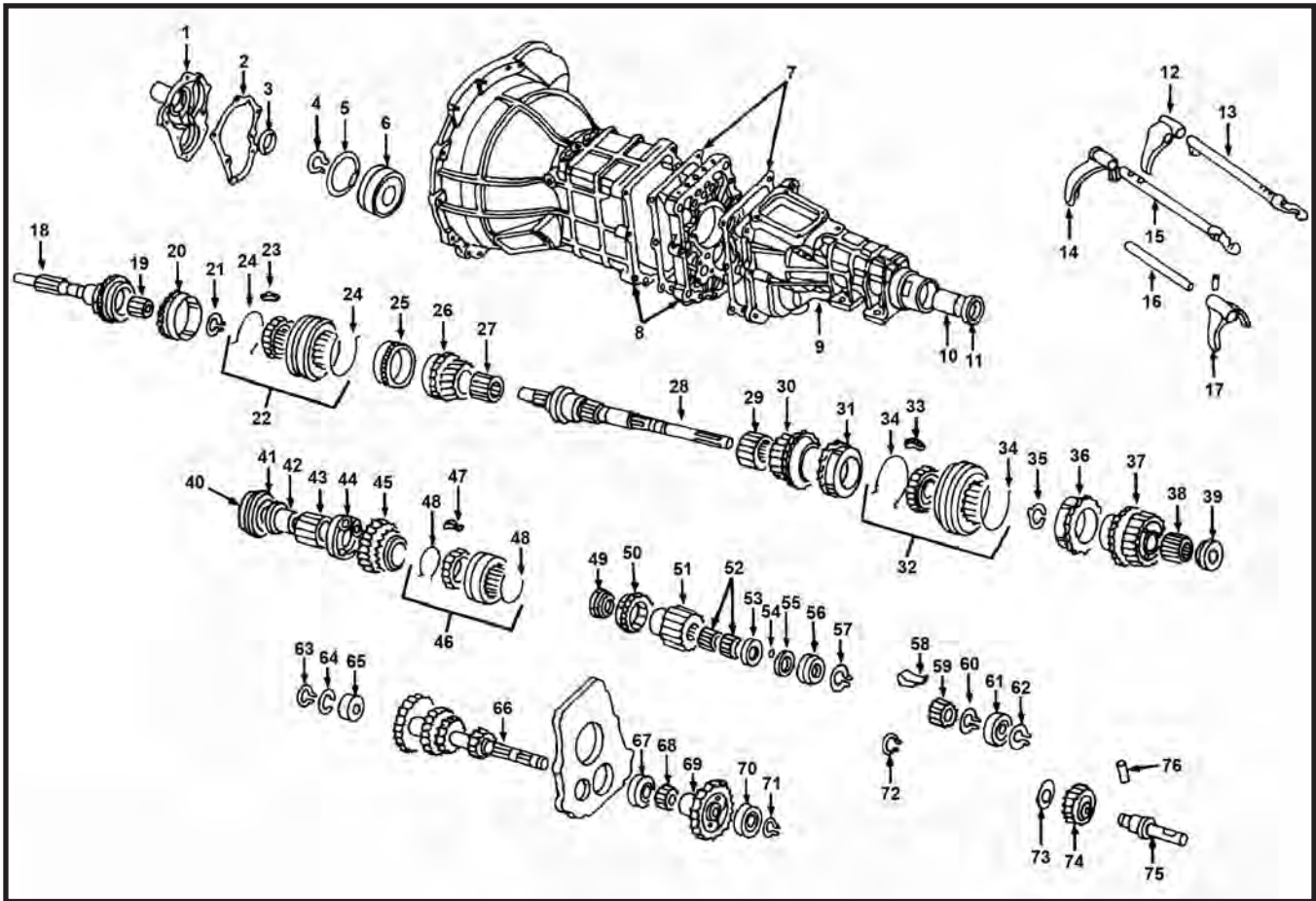

ILL #	MIDWEST #	REF #	REPLACEMENT PART DESCRIPTION
18	ISUZU-16		INPUT 23T - MSG-5ET, 1984-6/87
18	ISUZU-16A		INPUT 25T - MSG-5F, 9-1/4" O.A., 6/87-ON
18	ISUZU-16B		INPUT 25T - MSG-5F, 9-3/4" O.A., 6/87-ON
66	ISUZU-8		CLUSTER GEAR - MSG-5ET, 37-33-20-17, 1984-6/87
66	ISUZU-8A		CLUSTER GEAR - MSG-5F, 46-38-31-21, 6/87-92
66	ISUZU-8B		CLUSTER GEAR - MSG-5F, 46-38-27-21, 1992-95
20/25/50	ISUZU-14		SYNCHRO RING - MSG-5ET, 3-4-5, 1984-6/87
31/36	ISUZU-14A		SYNCHRO RING - MSG-5ET, 1-2, 1984-6/87
20/25	ISUZU-14B		SYNCHRO RING - MSG-5F, 3-4, 6/87-ON
31/36	ISUZU-14D		SYNCHRO RING - MSG-5F, 1-2, 6/87-ON
20/25/50	ISUZU-14G		SYNCHRO RING - MSG-5F, 5/4, 6/87-ON
2/7	LUV-55		GASKET SET - MSG-5ET, 1984-6/87
2/7	ISUZU-55		GASKET SET - MSG-5F, 196/87-ON

KITS

T220R	→	BEARING, SEAL AND GASKET KIT 7/87-92
T220RA	→	BEARING, SEAL AND GASKET KIT 92-ON - 3-PC., 5-REV. SYNCHROS HAVE DIFFERENT INSIDE TAPER
T220RB	→	BEARING, SEAL AND GASKET KIT 98-ON - 1-2 RINGS, 3-PC., 5-REV. SYNCHROS HAVE SAME INSIDE TAPER

MITSUBISHI® D50 STYLE

REPLACES 81-ON, 2WD, 4WD

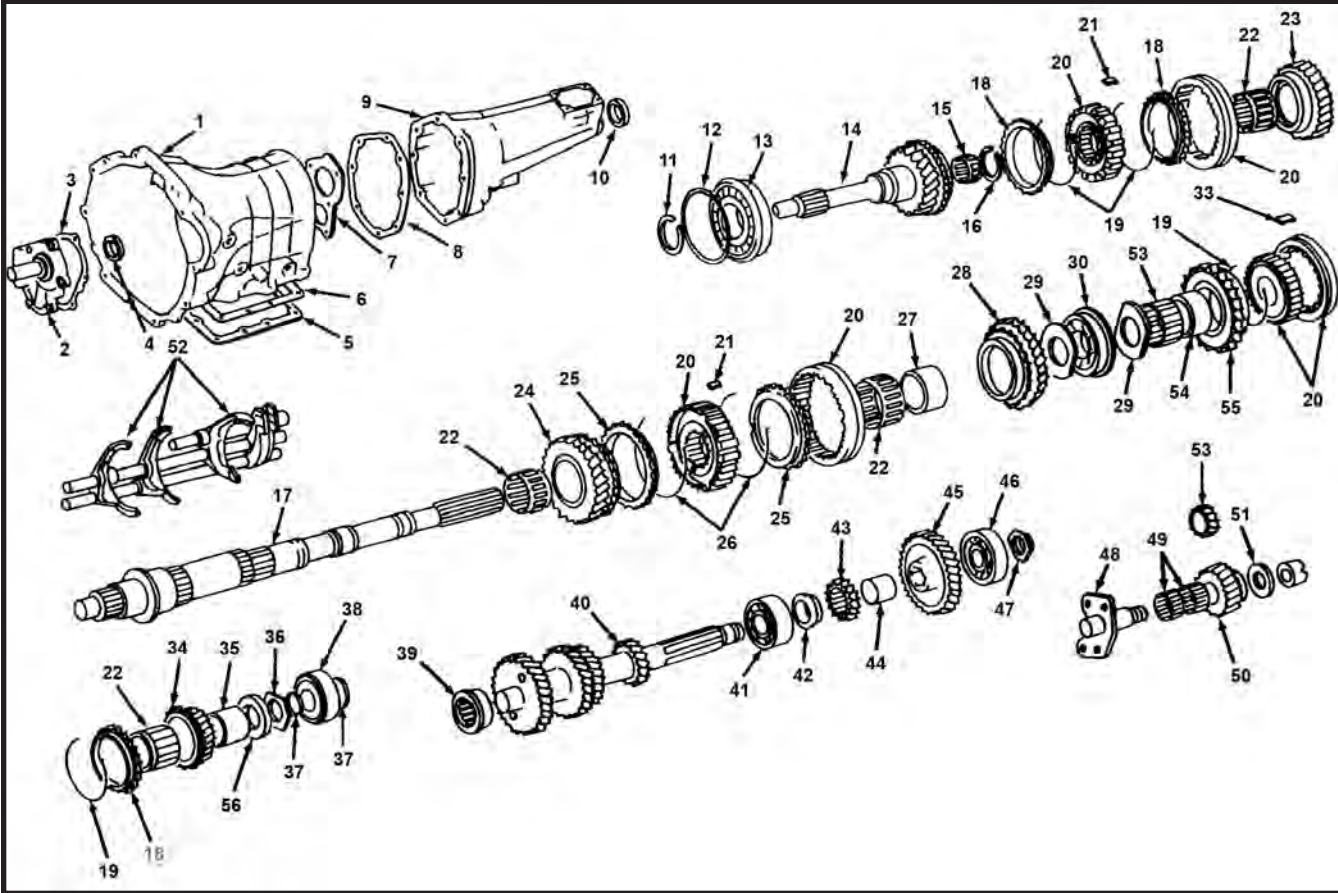

ILL #	MIDWEST #	REF #	REPLACEMENT PART DESCRIPTION
14	D50-16		INPUT 19T, 6307N BEARING
14	D50-16A		INPUT 19T, F6307X BEARING
14	D50-16B		INPUT 19T, TMSC0788N BEARING
18	MIT-14A		SYNCHRO RING 3-4-5
19	MIT-2.5		SYNCHRO ASSY 3-4
20	FM145-40		SYNCHRO ASSY 5-REV.
25	MIT-14B		SYNCHRO RING 2ND
25	MIT-14C		SYNCHRO RING 1ST
28	MIT-14H		SYNCHRO RING REVERSE
40	D50-8		CLUSTER 28-26-20-13 - ROLLER BEARINGS
40	D50-8A		CLUSTER 28-26-20-13 - TAPERED BEARINGS
52	D50-30A		FORK 1-2
52	D50-89A		FORK 3-4
52	D50-31A		FORK 5-REV.

KITS

T189R	→ BEARING, SEAL & GASKET KIT - INPUT BEARING TMSC0788N
T304R	→ BEARING, SEAL & GASKET KIT - V6 - 10/91-ON
T310R	→ BEARING, SEAL & GASKET KIT - INPUT F6307X-1-1
T415R	→ BEARING, SEAL & GASKET KIT - INPUT BEARING 307L - DOUBLE BALL ON M/S
T510R	→ BEARING, SEAL & GASKET KIT - INPUT 307L - SINGLE BALL ON M/S
D50-55	→ GASKET SET

PLEASE CALL WITH INPUT BEARING NUMBER FOR BEARING KIT

NISSAN® RS5F30A, 31A STYLE

REPLACES PULSAR, SENTRA, STANZA

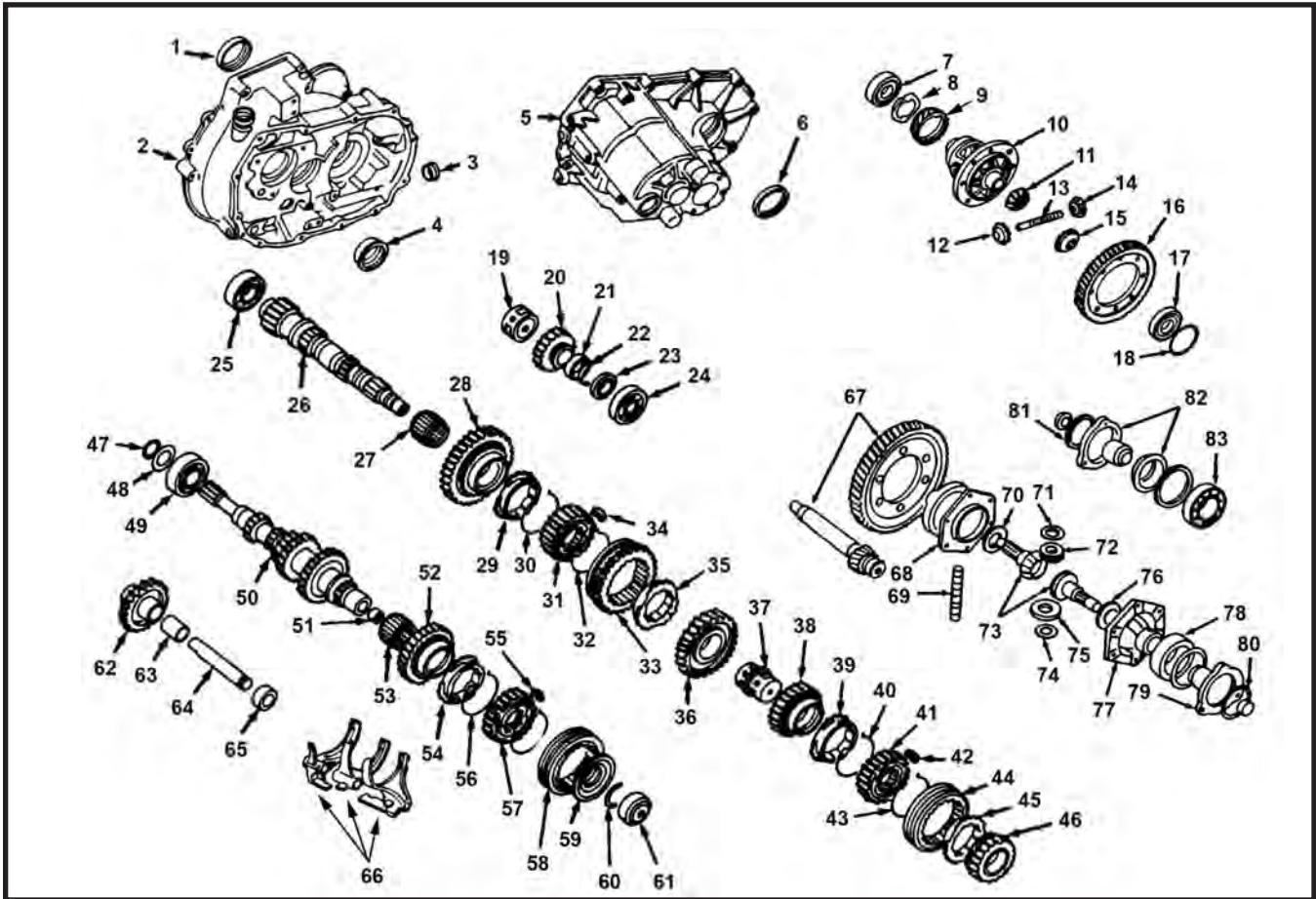

ILL #	MIDWEST #	REF #	REPLACEMENT PART DESCRIPTION
20	SEN-5	32341-M8800	5TH GEAR, 45T - 1 I.D. GROOVE, 3.15" O.D., 82-86 (RS5F30A)
20	SEN-5A	32341-53A00	5TH GEAR, 45T - 3.18" O.D., 87-90 (RS5F31A)
57/58	SEN-40	32610-M8012	SYNCHRO HUB/SLEEVE, 5TH, ALL
29/35/39/ 45/54	SEN-14	32607-M8001	SYNCHRO RING, ALL 82-87
29	SEN-14A	32607-D0100	SYNCHRO RING 1ST, 88-92

KITS

BEARING SEAL & GASKET KIT

T714R	→	- PULSAR:	82-86 RS5F30A (1.6L)
		- SENTRA:	82-83 RN4F30A/RN5F30A (1.5L) 82-87 RN4F30A/RN5F30A (1.6L) 82-86 RN4G30/RN5F30A (1.7L) DIESEL
T213R	→	-PULSAR:	82-86 RS5F31C (1.5L) 87-90 RS5F31A (1.6L)
		-SENTRA:	88-90 RN4F31A (1.6L) 86-90 RS5F31A (1.6L)
		-STANZA:	81-86 RS5F31A (2.0L)

NISSAN® FS5R30A STYLE

(V6): 300ZX, FRONTIER, HARDBODY, PATHFINDER

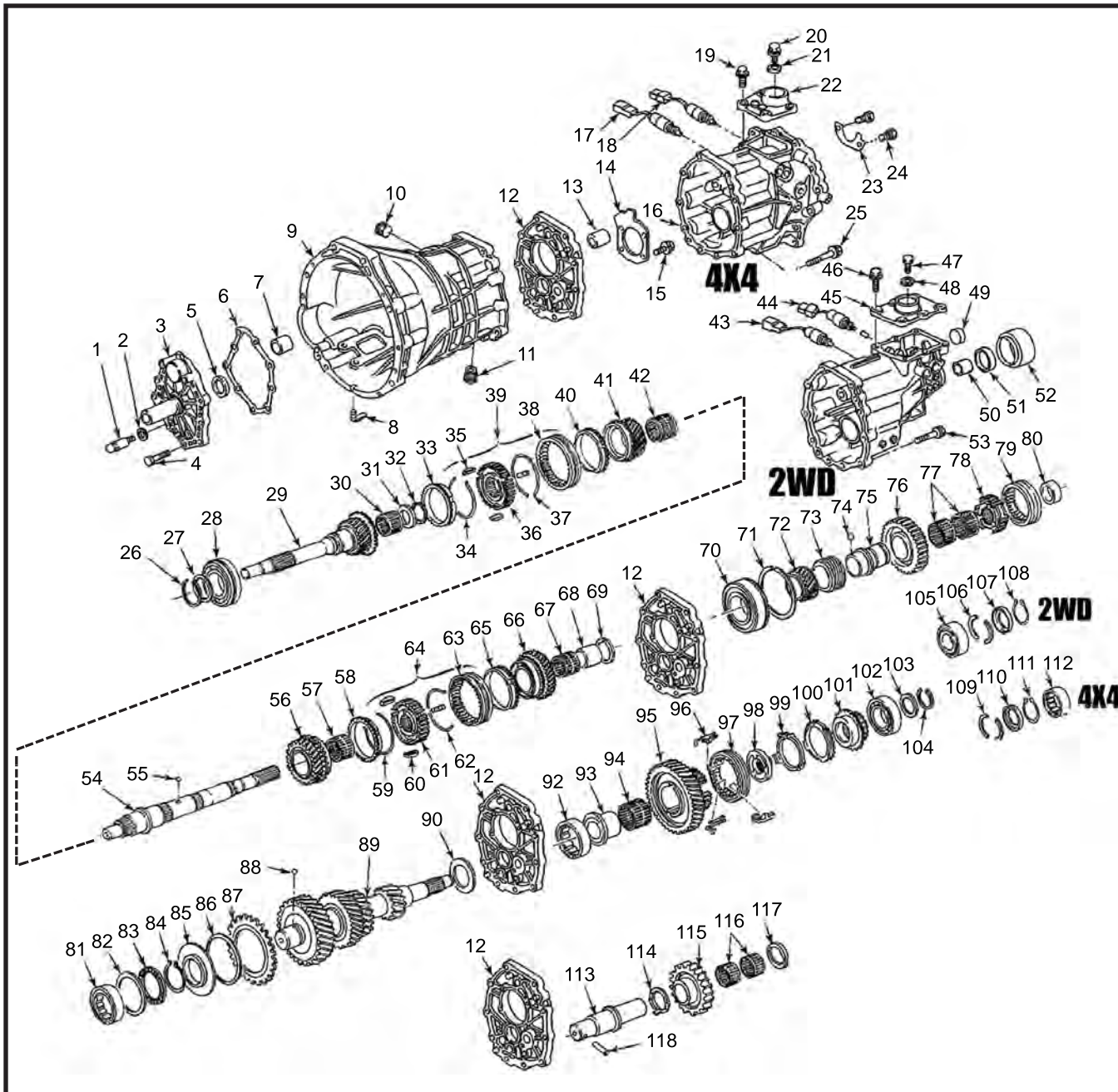

NISSAN® FS5R30A STYLE (cont.)

ILL #	MIDWEST #	REF #	REPLACEMENT PART DESCRIPTION
5	1981		INPUT - FRONT SEAL
15	6308N		INPUT - FRONT BEARING
29	NISV6-16		INPUT - 4X4, 3/87-95
33	NIS-14M		SYNCHRO RING - 4TH, 3/87-1/92
40	NIS-14M		SYNCHRO RING - 3RD, 3/87-1/92
58	NIS-14K		SYNCHRO RING - 2ND, 3/87-1/92
65	NIS-14L		SYNCHRO RING - 1ST, 3/87-ON
70	6308N		MAINSHAFT - MIDDLE BEARING
89	NISV6-8		COUNTERSHAFT, 33-31-21-13, 4X4
99	NIS-14H		SYNCHRO RING - 5TH, ALL
100	NIS-14J		SYNCHRO RING - REVERSE, ALL
102	63/22		COUNTERSHAFT - RR. BEARING
105	62-32		MAINSHAFT - RR. BEARING, 4X2

KITS

BEARING, SEAL & GASKET KIT

T240R	→	-PATHFINDER: 86-ON FS5R30A (3.0L, 3.3L, 3.5L) -FRONTIER: 2000-ON FS5R30A (3.3L) -HARDBODY: 86-95 FS5R30A (3.0L) -300ZX: 87-96 FS5R30A (3.0L) (ALL)
-------	---	---

BEARING, SEAL & GASKET KIT WITH RINGS

T240WX	→	-PATHFINDER: 86-87 FS5R30A (3.0L) (1-2 RING = 42T) -HARDBODY: 86-87 FS5R30A (3.0L) (1-2 RING = 42T)
T240RLMK	→	-PATHFINDER: 87-92 FS5R30A (3.0L) (1-2 RING = 54T) -HARDBODY: 87-92 FS5R30A (3.0L) (1-2 RING = 54T) -300ZX: 86-89 FS5R30A (TURBO) (1-2 RING = 54T)
T240RCMK	→	-PATHFINDER: 92-98 FS5R30A (3.0L, 3.3L) (2-3 RING = MULTIPIECE) -HARDBODY: 92-95 FS5R30A (3.0L) (2-3 RING = MULTIPIECE) -300ZX: 89-96 FS5R30A (3.0L) (TWIN & NON-TURBO) (2-3 RING = MULTIPIECE)
T240RDMK	→	-PATHFINDER: 98-02 FS5R30A (3.3L, 3.5L) (3-4 RING = 74.95mm I.D.) -FRONTIER: 00-ON FS5R30A (3.3L NON-SUPERCHARGED) (3-4 RING = 74.95mm I.D.)

Bearing Kits Heavy Duty, Light Duty & Performance

MIDWESTTM
TRUCK & AUTO PARTS INC.

MotiveGear Performance WORLD AMERICAN Motive Gear

Bearing Kits
Heavy Duty, Light Duty & Performance

- OE Quality Replacement Parts
- Backed by Warranty
- Centralized Distribution Locations Means Quick Delivery

Bearing Kits

This catalog has all of our O.E. quality bearing kits associated with manual transmission, transfer case & axle/differential applications. A must have for distributors and rebuilders alike.

NISSAN® FS5W71 STYLE

(4 CYL. TRUCK/CAR, V6 CAR)

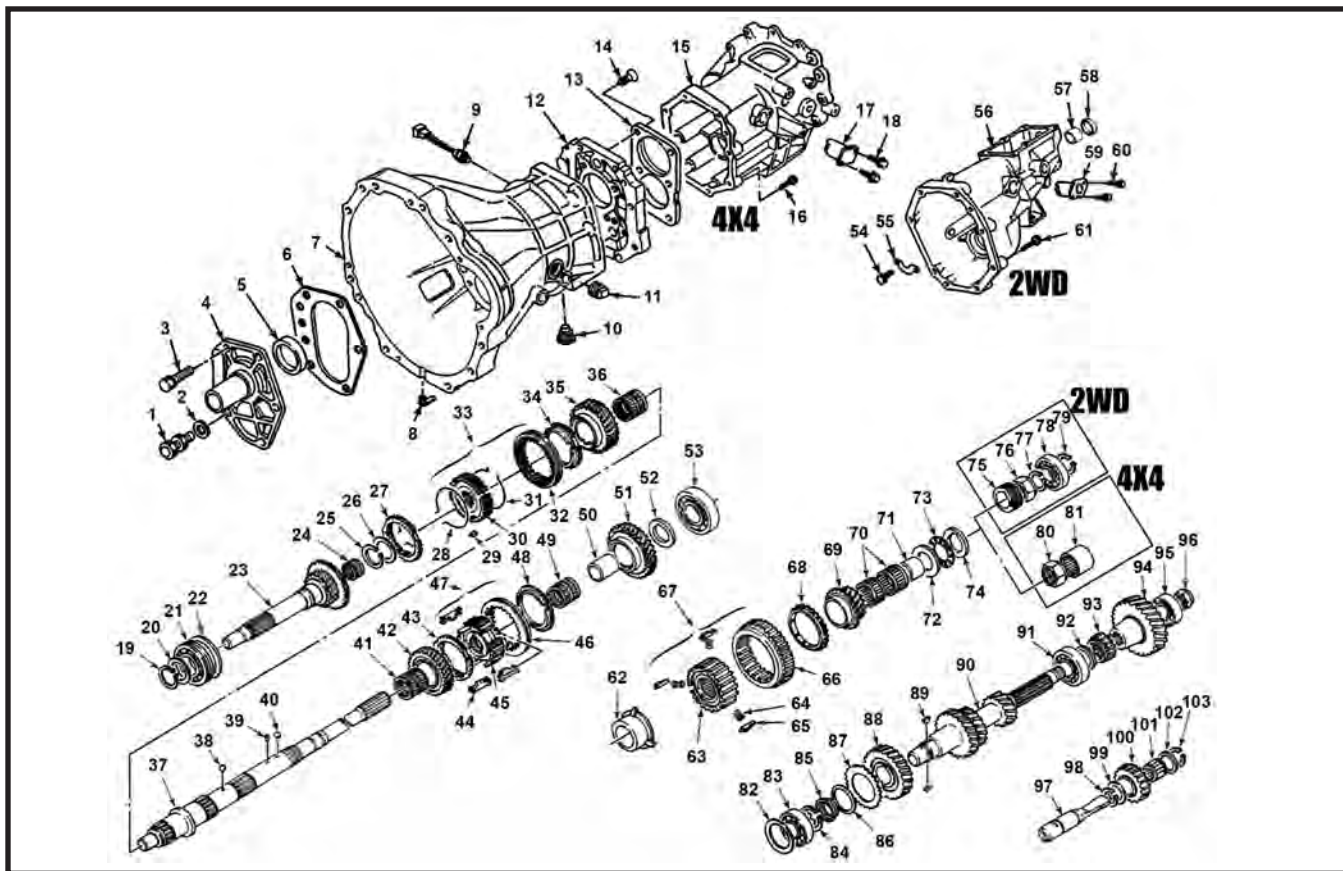

ILL #	MIDWEST #	REF #	REPLACEMENT PART DESCRIPTION
4	NIS-6		FRONT BEARING RETAINER - 1974-83
	NIS-6A		FRONT BEARING RETAINER - 1984-ON
5	1981		FRONT BEARING RETAINER - SEAL
21	306L		INPUT - BEARING
23	NIS-16		INPUT - 1986-ON, 4X4 (21/32T)
	NIS-16A		INPUT - 1986-93, 2WD (21/32T)
	NIS-16B		INPUT - 1986-ON, 2WD (22/32T)
24	K20X26X20		INPUT - POCKET BEARING
27	NIS-14		SYNCHRO RING - 4TH, 1974-7//93, 2WD
			SYNCHRO RING - 4TH, 1984-7/93, 4X4
	NIS-14G		SYNCHRO RING - 4TH, 7/93-ON, 2WD / 4X4
			SYNCHRO RING - 4TH, 1998-ON, 2WD / 4X4 (FRONTIER)
	NIS-14U		SYNCHRO RING - 4TH, 2000-ON, 2WD / 4X4 (XTERRA)
34	NIS-14		SYNCHRO RING - 3RD, 1974-7/93, 2WD
			SYNCHRO RING - 3RD, 1980-7/93, 4X4
	NIS-14G		SYNCHRO RING - 3RD, 7/93-ON, 2WD / 4X4
			SYNCHRO RING - 3RD, 1998-ON, 2WD / 4X4
	NIS-14Q		SYNCHRO RING - 3RD, (OUTER) 2000-ON, 2WD / 4X4 (XTERRA)
	NIS-14R		SYNCHRO RING - 3RD, (INNER) 2000-ON, 2WD / 4X4 (XTERRA)
37	NIS-2		MAINSHAFT - 11/85-8/86 (4X4 MARRIED)
	NIS-2A		MAINSHAFT - 8/86-ON (4X4 MARRIED)
39/62	NIS-5A		KIT - 5TH GEAR SET, 1978-85, 4X4 (24T/45T)
	NIS-5		KIT - 5TH GEAR SET, 1986-93, 4X4 (21T/39T)
	NIS-5C		KIT - 5TH GEAR SET, 1993-ON, 4X4 (21T/39T)
	NIS-5B		KIT - 5TH GEAR SET, 1986-ON, 2WD (22T/37T)
43	NIS-14		SYNCHRO RING - 2ND, 1974-7/93, 2WD
			SYNCHRO RING - 2ND, 1980-7/93, 4X4
43	NIS-14B		SYNCHRO RING - 2ND, 6/86-7/93, 2WD / 4X4
	NIS-14Q		SYNCHRO RING - 2ND, (OUTER) 7/93-ON, 4X4
			SYNCHRO RING - 2ND, (OUTER) 7/93-1996, 2WD
			SYNCHRO RING - 2ND, (OUTER) 1998-ON, 4X4 (FRONTIER)
			SYNCHRO RING - 2ND, (OUTER) 2000-ON, 2WD / 4X4 (XTERRA)

NISSAN® FS5W71 STYLE (cont.)

ILL #	MIDWEST #	REF #	REPLACEMENT PART DESCRIPTION
43 (cont.)	NIS-14R		SYNCHRO RING - 2ND, (INNER) 7/93-ON, 4X4 SYNCHRO RING - 2ND, (INNER) 7/93-96, 2WD SYNCHRO RING - 2ND, (INNER) 1998-ON, 4X4 (FRONTIER) SYNCHRO RING - 2ND, (INNER) 2000-ON, 2WD / 4X4 (XTERRA)
	NIS-14U		SYNCHRO RING - 2ND, 1997-ON, 2WD SYNCHRO RING - 2ND, 1998-ON, 2WD (FRONTIER)
48	NIS-14		SYNCHRO RING - 1ST, 1974-6/86, 2WD SYNCHRO RING - 1ST, 1980-6/86, 4X4
	NIS-14B		SYNCHRO RING - 1ST, 6/86-7/93, 2WD / 4X4
	NIS-14U		SYNCHRO RING - 1ST, 7/93-ON, 2WD / 4X4 SYNCHRO RING - 1ST, 1998-ON, 2WD / 4X4 (FRONTIER) SYNCHRO RING - 1ST, 2000-ON, 2WD / 4X4 (XTERRA)
53	306		MAINSHAFT - BEARING (CENTER)
57	NISSAN-62		RR. EXT. HOUSING - BUSHING, 2WD
58	13944		RR. EXT. HOUSING - SEAL, 2WD
62			SEE #39
66	NIS-36		REVERSE SLIDER - 1981-92 (36T)
	NIS-37		REVERSE SLIDER - 1993-ON (36T)
68	NIS-14A		SYNCHRO RING - 5TH - ALL
76	NIS-204		MAINSHAFT - NUT (REVERSE THREAD)
	NIS-204A		MAINSHAFT - NUT (NORMAL THREAD)
78	205		MAINSHAFT - BEARING (REAR)
80	NIS-204		MAINSHAFT - NUT (REVERSE THREAD)
	NIS-204A		MAINSHAFT - NUT (NORMAL THREAD)
83	63/22		COUNTERSHAFT - BEARING, 1974-83 (FRONT)
90	NIS-8		COUNTERSHAFT - 1986-ON, 4X4
91	305		COUNTERSHAFT - BEARING (CENTER)
93	NIS-46		COUNTERSHAFT - REVERSE GEAR (15T)
95	204		COUNTERSHAFT - BEARING (REAR) (BALL TYPE)
	NIS-29		COUNTERSHAFT - BEARING (REAR) (ROLLER TYPE)
96	NIS-220		COUNTERSHAFT - NUT
100	NIS-10		REVERSE IDLER - (21T)
	NIS-10A		REVERSE IDLER - (22T)
	NIS-14T		SYNCHRO RING - REVERSE, 1993-ON, 4X4 SYNCHRO RING - REVERSE, 1996-ON, 2WD
			MAINSHAFT - REVERSE GEAR, 1993-ON
	NIS-37		MAINSHAFT - REVERSE SLIDER, 1993-ON
	NIS-40		MAINSHAFT - REVERSE SLIDER, 1993-ON
	NIS-REVKIT		KIT - REVERSE, 1981-93 (#55, 93, 100)

KITS

BEARING, SEAL & GASKET KITS	
T104R	-200SX: 80-84 FS5W71C 2WD (2.0L, 2.2L)
T313R	-200SX: 84-86 FS5W71C 2WD (1.8L) (TURBO)
	-200SX: 84-88 FS5W71C 2WD (2.0L)
	-200SX: 87-88 FS5W71C 2WD (3.0L)
	-240SX: 88-97 FS5W71H 2WD (2.4L)
T133RE	-240SX: 93-97 FS5W71H 2WD (2.4L) (POCKET NDL. BEARING - 31mm)
T104R	-280Z: 77-78 FS5W71A 2WD (2.8L)
	-280ZX: 79-83 FS5W71A 2WD (2.8L)
T313R	-300ZX: 83-89 FS5W71C 2WD (3.0L)
T173R	-510: 78-81 FS5W71C 2WD (1.8L)
T104R	-720 SERIES: 74-84 2WD / 4X4 FS5W71A, C (2.0L)
T313R	-720 SERIES: 84-86 2WD / 4X4 FS5W71C (2.4L, 2.5L)
T104R	-810: 79-81 FS5W71A, C 2WD (2.4L, 2.8L DIESEL)
T122RE	-FRONTIER: 98-00 FS5W71C 4X4 (2.4L)
T133RE	-FRONTIER: 98-ON FS5W71C 2WD (2.4L)
T313R	-HARDBODY: 86-97 FS5W71E 2WD (2.4L, 2.5L)
T122R	-HARDBODY: 86-89 FS5W71G 4X4 (2.4L) (RR. C/S BEARING = BALL TYPE)
T122RA	-HARDBODY: 90-96 FS5W71G 4X4 (2.4L) (RR. C/S BEARING = ROLLER TYPE)
T122RE	-HARDBODY: 96-98 FS5W71G 4X4 (2.4L) (POCKET NDL. BEARING = 31mm)
T104R	-MAXIMA: 82-84 FS5W71C (2.4L, 2.8L DIESEL)
T122R	-PATHFINDER: 86-88 FS5W71G (2.4L)
T313R	-VAN: 87-90 F4W71E, 2WD
T133RE	-XTERRA: 00-ON FS5W71C (2.4L) 2WD
T122RE	-XTERRA: 00-ON FS5W71G 4X4 (2.4L)

KITS CONTINUED ON NEXT PAGE...

NISSAN® FS5W71 STYLE (cont.)

KITS (cont.)

BEARING, SEAL & GASKET KITS (W/RINGS)

T104RMK	→	-200SX: 80-84 FS5W71C, 2WD (2.0L, 2.2L) (ALL RINGS SAME SIZE AND TYPE)
T313RAMK	→	-200SX: 84-86 FS5W71C, 2WD (1.8L) (TURBO)
	→	-200SX: 84-88 FS5W71C, 2WD (2.0L) (2ND SNCHRO RING = 1 PC.)
	→	-200SX: 87-88 FS5W71C, 2WD (3.0L)
T313RBMK	→	-200SX: 1988 FS5W71, 2WD (2.0L, 3.0L) (2ND SYNCHRO RING = 2 PC.)
T313RCMK	→	-240SX: 93-97 FS5W71H, 2WD (2.4L)
T104RAMK	→	-280Z: 77-78 FS5W71A, 2WD (2.8L) (FIBER STYLE 5TH RING NOT INCLUDED)
	→	-280ZX: 79-80 FS5W71A, 2WD (2.8L) (FIBER STYLE 5TH RING NOT INCLUDED)
T104RMK	→	-280ZX: 80-83 FS5W71A, 2WD (2.4L, 2.8L DIESEL) (5TH RING = BRASS)
T313RAMK	→	-300ZX: 83-87 FS5W71C, 2WD (3.0L)
T313RBMK	→	-300ZX: 87-88 FS5W71C, 2WD (3.0L) (2ND SYNCHRO RING = 2 PC.)
T104RMK	→	-720 SERIES: 80-82 FS5W71C, 2WD / 4X4 (2.2L) (FRT. C/S BRG. = 60mm)
	→	-720 SERIES: 82-84 FS5W71C, 2WD / 4X4 (2.0L, 2.4L, 2.5L) (FRT. C/S BRG. = 60mm OD)
T313RMK	→	-720 SERIES: 84-86 FS5W71C, 2WD / 4X4 (2.0L, 2.4L, 2.5L) (FRT. C/S BRG. = 61mm OD)
T104RAMK	→	-810: 79-80 FS5W71A, 2WD (2.0L) (FIBER STYLE 5TH RING NOT INCLUDED)
T122REMK	→	-FRONTIER: 98-00 FS5W71C, 4X4 (2.4L)
T313RAMK	→	-HARDBODY: 88-89 F4W71E, 2WD (2.4L) (4 SPEED)
T313RAMK	→	-HARDBODY: 86-83 FS5W71E, 2WD (2.4L)
T313RAMK	→	-HARDBODY: 86-93 FS5W71E, 2WD (2.5L) (DIESEL)
T313RBMK	→	-HARDBODY: 93-95 FS5W71E, 2WD (2.4L) (2ND SYNCHRO RING = 2 PC.)
T313RCMK	→	-HARDBODY: 1996 FS5W71E, 2WD (2.4L) (2ND SYNCHRO RING = 2 PC.)
T313RDMK	→	-HARDBODY: 1997 FS5W71E, 2WD (2.4L) (SINGLE PC. RINGS + REV. SYNCHRO RING)
T122RMK	→	-HARDBODY: 86-89 FS5W71G, 4X4 (2.4L) (RR. C/S BRG. = BALL TYPE)
T122RAMK	→	-HARDBODY: 90-92 FS5W71G, 4X4 (2.4L) (RR. C/S BRG. = ROLLER TYPE)
T122RBMK	→	-HARDBODY: 92-93 FS5W71G, 4X4 (2.4L) (INCLUDES REV. SYNCHRO RING)
T122RCMK	→	-HARDBODY: 93-96 FS5W71G, 4X4 (2.4L) (INCLUDES REV. SYNCHRO RING)
T122REMK	→	-HARDBODY: 96-98 FS5W71G, 4X4 (2.4L) (POCKET NDL. BRG. - 31mm)
T122RMK	→	-PATHFINDER: 86-88 FS5W71G (2.4L)
T313RAMK	→	-VAN: 87-90 F4W71E, 2WD (2.4L) (4 SPEED)
T122RFMK	→	-XTERRA: 2000-ON FS5W71G, 4X4
T313RGMK	→	-XTERRA: 2000-ON FS5W71G, 2WD



G52 STYLE TOYOTA® TRUCK, 4 RUNNER, 1983-ON

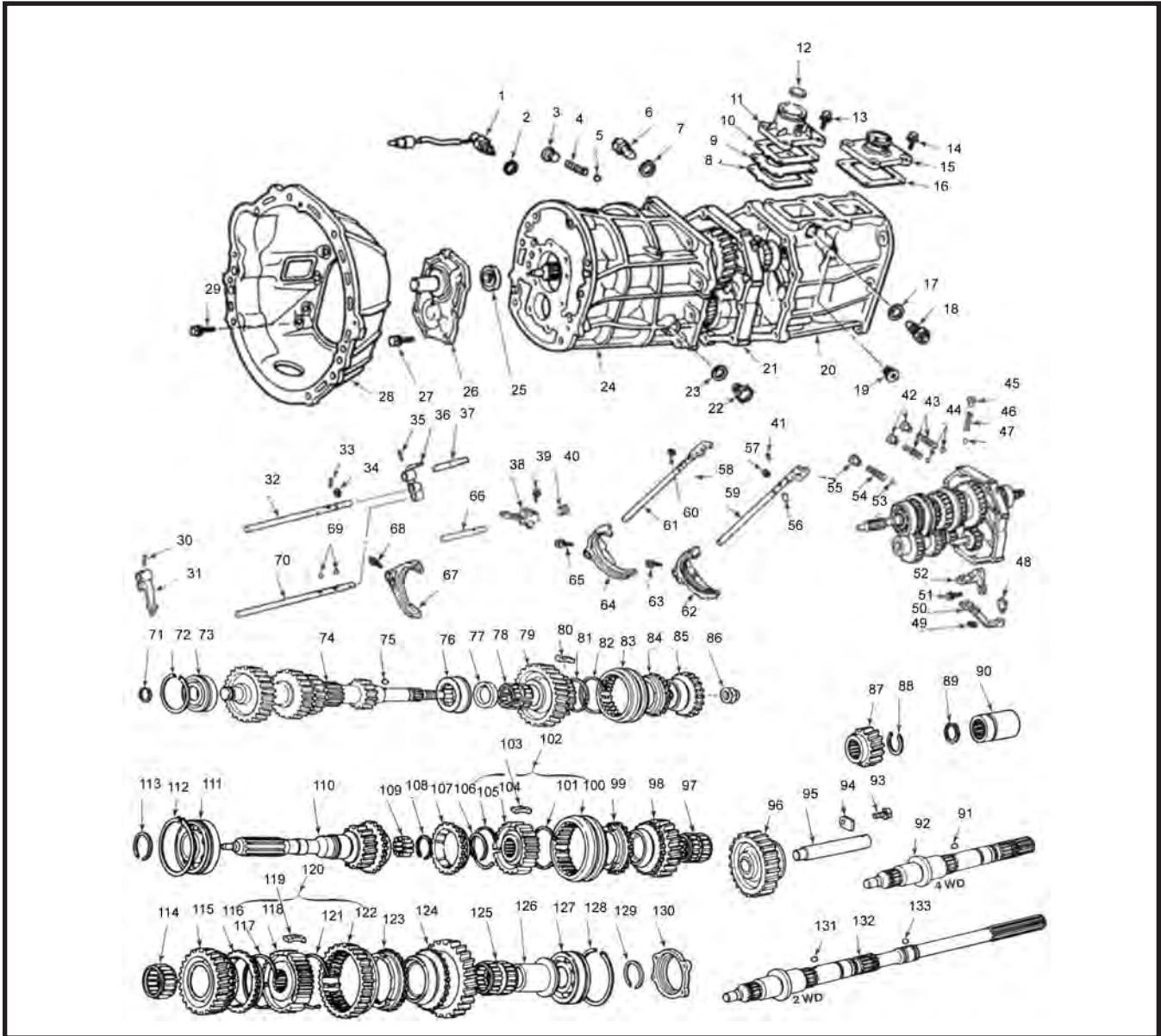

ILL #	MIDWEST #	REF #	REPLACEMENT PART DESCRIPTION
25	1981		INPUT SEAL - G52 - ALL
26	G52-6	33131/28010	FRONT BEARING RETAINER - TO 1983
26	G52-6A	33131/26020	FRONT BEARING RETAINER - 1984-ON
62	83500527		1-2 FORK KIT - TO REPLACE IRON FORK
62	83502662	33212-35023	1-2 FORK - ALUM. (LATE)
64	83500563	4740236	3-4 FORK KIT (INCLUDES 3-4 SLIDER)
67	83500637	33214-35020	5TH FORK - IRON
67	4746656		5TH FORK - ALUM. (LATE)
71	83500582	90520-23089	SNAP RING
72	83500612	90520-49222	SNAP RING
73	NUPK22051NC3		COUNTERSHAFT FRONT BEARING
74	G52-8	33421-26071	COUNTERSHAFT 1988, 45-31-20-13
74	33421-35190		COUNTERSHAFT - 1980-ON
76	31RUK552NRC3		BEARING - REAR C/S
77	83506025	33349-35010	THRUST WASHER
78	83500644	90364-26002	NEEDLE BEARING - C/S 5TH GEAR

G52 STYLE (cont.)

ILL #	MIDWEST #	REF #	REPLACEMENT PART DESCRIPTION
79	83506022	33046-35061	5TH GEAR C/S - 45T
79	G52-5		5TH GEAR SET - 24/45T
80	83500641	33394-30010	SYNCHRO KEYS - 5TH GEAR (3 REQ.)
82	83500568	33371-14010	SYNCHRO SPRING
83	AX5-15	33395-28010	5TH GEAR SYNCHRO SLEEVE - IRON FORK
83	AX5-15D	4746657	5TH GEAR SYNCHRO SLEEVE - ALUM. FORK
84	TOY-14	33367-14010	SYNCHRO RING
85	83506024	33318-35030	SYNCHRO CONE - C/S 5TH GEAR
86	83500572	90179-20002	NUT - C/S REAR
87	83500971	33336-28020	5TH GEAR M/S - 24T - CAN USE G52-5
90	33399-35020		COUPLER 4X4 - TO 1988
90	33399-35030		COUPLER 4X4 - 1989-ON
92	83502117	33321-35092	MAIN SHAFT - 2WD
92	33321-35111		MAIN SHAFT - 4WD
97	83500576	90364-35004	NEEDLE BEARING - 3RD GEAR
98	AX5-11A	83506019	3RD GEAR - 27T
99	TOY-14	33367-14010	SYNCHRO RING 3-4
100	83500563	4740236	SYNCHRO SLEEVE KIT 3-4 (INCLUDES FORK)
101	83500568	33371-14010	SYNCHRO SPRING 3-4 (2 REQ.)
102	G52-2.5		SYNCHRO ASSY 3-4
103	83506029	33366-35040	SYNCHRO KEY 3-4 (3 REQ.)
104	83500562		SYNCHRO HUB 3-4
105	83500568	33371-14010	SYNCHRO SPRING 3-4 (2 REQ.)
107	TOY-14	33367-14010	SYNCHRO RING 3-4
108/106	83500602	90520-28010	SNAP RING
109	83500574	39692-4030	NEEDLE BEARINGS - POCKET - L52-16 (14 REQ.)
109	83502680	39692-4040	NEEDLE BEARINGS - POCKET - G52-16 (13 REQ.)
110	G52-16	33301/26012	INPUT SHAFT - 1984-ON
111	32BC0851NRB	90363-32017	INPUT BEARING - L52-16
111	32TM03NX	90363-32024	INPUT BEARING - G52-16
112	90520-76002		SNAP RING
113	90520-30214		SNAP RING
114	83500577	90364-38002	NEEDLE BEARING - 2ND GEAR
115	83500551	33033-35010	2ND GEAR - 28T - TO 1988
115	33033-35021		2ND GEAR - 28T - 1989-ON
116	TOY-14A	33368-20012	SYNCHRO RING 1-2
117	83500569	33371-14031	SYNCHRO SPRING 1-2 (2 REQ.)
118	83500561	33361-35020	SYNCHRO HUB 1-2
119	83500564	33365-35020	SYNCHRO KEYS 1-2 (3 REQ.)
120	G52-80		SYNCHRO ASSY 1-2
121	83500569	33371-14031	SYNCHRO SPRING 1-2 (2 REQ.)
122	83500555	33331-28010	SYNCHRO SLEEVE 1-2
123	TOY-14A	83500567	SYNCHRO RING 1-2
124	83500550		1ST GEAR - 33T - TO 1988
124	83506017		1ST GEAR - 33T - 1989-ON
125	83500578	90364-39002	NEEDLE BEARING - 1ST GEAR - TO 1988
125	83506031	90364-39011	NEEDLE BEARING - 1ST GEAR - 1989-ON
126	83500560	33355-35011	INNER RACE - NEEDLE BEARING - TO 1988
126	83506026	33355-35020	INNER RACE - NEEDLE BEARING - 1989 -ON
127	30BCS19-2NSLNR		MAIN SHAFT REAR BEARING
128	90520-71221		SNAP RING
130	83500508	33151-28010	REAR RETAINER - ALL
132	83502117	33321-35092	MAIN SHAFT - 2WD

G52 STYLE (cont.)

KITS

T161R	→	BEARING, SEAL AND GASKET KIT w/ 32TM03 OR 32BC54 INPUT BEARING
T161TR	→	BEARING, SEAL AND GASKET KIT w/ B32TM03X OR 32BC58-2MT2N INPUT BEARING
T610R	→	BEARING, SEAL AND GASKET KIT w/ B32-144R OR 32BC08SIN INPUT BEARING
RKAX5	→	SYNCHRO RING KIT
G52-55	→	GASKET KIT

L52 STYLE TOYOTA® PICK-UP 1981-83

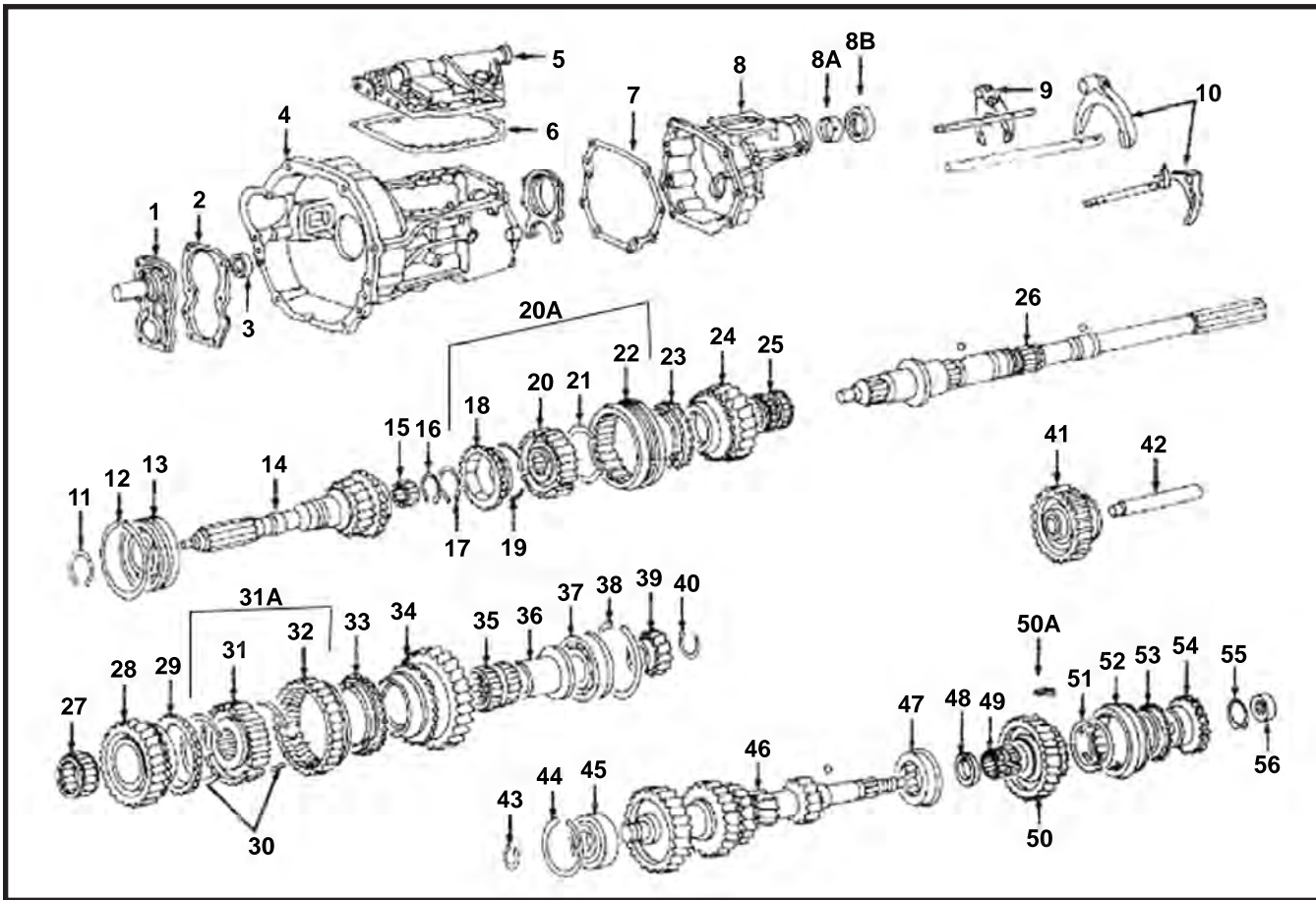

ILL #	MIDWEST #	REF #	REPLACEMENT PART DESCRIPTION
1		33131-35022	FRONT BEARING RETAINER
2		33132-35022	GASKET - FRONT RETAINER
3	1981	90311-30115	FRONT SEAL
4		33111-35051	MAIN CASE
5		33121-35080	TOP COVER
6		33122-35020	GASKET TOP COVER
7	TC2030-L52		4X4 ADAPTER GASKET
8A	W50-62		TAIL HOUSING BUSHING 2WD
8B	12745	90311-32001	OUTPUT SEAL 4WD
8B	223840	90311-38040	OUTPUT SEAL 2WD
9		33212-35010	SHIFT FORK 1-2
10		33213-35020	SHIFT FORK 3-4
10		33211-35020	SHIFT FORK REV.
10		33214-35010	SHIFT FORK 5TH
11		90520-30214	SNAP RING
12		90520-76002	SNAP RING
13	32BC08SINR		FRONT INPUT BEARING 80mm
13	032-2		ROLLER INPUT BEARING 74mm
13	63/32R2NA1		BALL INPUT BEARING 74mm
14	L52-16	33031-35031	INPUT - ALL
15	83500574	90361-06047	POCKET NEEDLES (14 REQ.)
18/23	TOY-14	33367-14010	SYNCHRO RING 3-4
19/21	83500568	33371-14010	SYNCHRO SPRING 3-4 (2 REQ.)

L52 STYLE (cont.)

ILL #	MIDWEST #	REF #	REPLACEMENT PART DESCRIPTION
20	83500562	33362-35020	INNER SYNCHRO HUB 3-4
N.I.	83506029	33366-35040	SYNCHRO KEY 3-4 (3 REQ.)
20A	L52-2.5	N/A	SYNCHRO ASSY 3-4
22	83500563	33364-35010	SYNCHRO SLEEVE/SLIDER 3-4
24	83506019	33034-35030	3RD GEAR - 27T
25	83500576	90364-35004	NEEDLE BEARING 3RD GEAR
26		33321/28010	MAIN SHAFT 4X4
27	83500577	90364-38002	NEEDLE BEARING - MAIN SHAFT 2ND
28	83500551	33033-35010	2ND GEAR MAIN SHAFT - 28T
29/33	TOY-14A	33368-20017	SYNCHRO RING 1-2
30	83500569	33371-14031	SYNCHRO SPRING 1-2 (2 REQ.)
31	83500561	33361-35020	SYNCHRO HUB 1-2
N.I.	83500564	33365-35020	SYNCHRO KEYS 1-2
31A	L52-80	N/A	SYNCHRO ASSY 1-2
32		33331-35040	REV. GEAR - MAIN SHAFT 1-2 SYNCHRO SLEEVE
34	83500550	33032-35010	1ST GEAR MAIN SHAFT - 33T
35	83500578	90364-39002	NEEDLE BEARING - 1ST GEAR
36	83500560	33355-35011	INNER RACE - 1ST GEAR NEEDLE BEARING
37	30BC519-2NSLNR		BEARING - MAIN SHAFT REAR
39	83500971	33336-28020	5TH GEAR MAIN SHAFT 24T - CAN USE G52-5
40		90520-25005	SNAP RING
N.I.	83500572	90179-20002	NUT REAR C/S
43	83500582	90520-23089	SNAP RING
44	83500612	90520-49222	SNAP RING
45	NUPK2205S1NC3	83506032	BEARING C/S FRONT
46	L52-8	33421-35402	CLUSTER GEAR - ALL
47	31RUKSS2NRC3	83500580	BEARING C/S REAR
48	83506025	33349-35010	THRUST WASHER
49	83500644	90364-26002	NEEDLE BEARING C/S 5TH
50	83506022	33046-35061	5TH GEAR C/S - 45T - CAN USE G52-5
50A	83500641	33394-30010	SYNCHRO KEYS - 5TH GEAR (3 REQ.)
51	83500568	33371-14010	SYNCHRO SPRING - 5TH GEAR
52	83500642	33395-28010	SYNCHRO SLEEVE - 5TH GEAR
53	TOY-14	33367-14010	SYNCHRO RING - 5TH GEAR
54	83506024	33318-35030	SYNCHRO CONE - C/S 5TH GEAR
55		90521-38001	SNAP RING
56		90365-18002	BEARING

KITS

T100R	→	BEARING, SEAL & GASKET KIT w/ B32-144R OR 32 BC08S1N INPUT BEARING
T100RMK	→	BEARING, SEAL & GASKET MASTER KIT W/ B32-144R OR 32 BC08S1N INPUT BEARING
T101R	→	BEARING, SEAL & GASKET KIT w/ 032-2 ROLLER INPUT BEARING
T101RMK	→	BEARING, SEAL & GASKET MASTER KIT w/ 032-2 ROLLER INPUT BEARING
T715R	→	BEARING, SEAL & GASKET KIT w/ 63-32 BALL INPUT BEARING
T715RMK	→	BEARING, SEAL & GASKET MASTER KIT w/ 63-32 BALL INPUT BEARING
RKAX5	→	SYNCHRO RING KIT
GS101-55	→	GASKET SET

TOYOTA® W56 STYLE

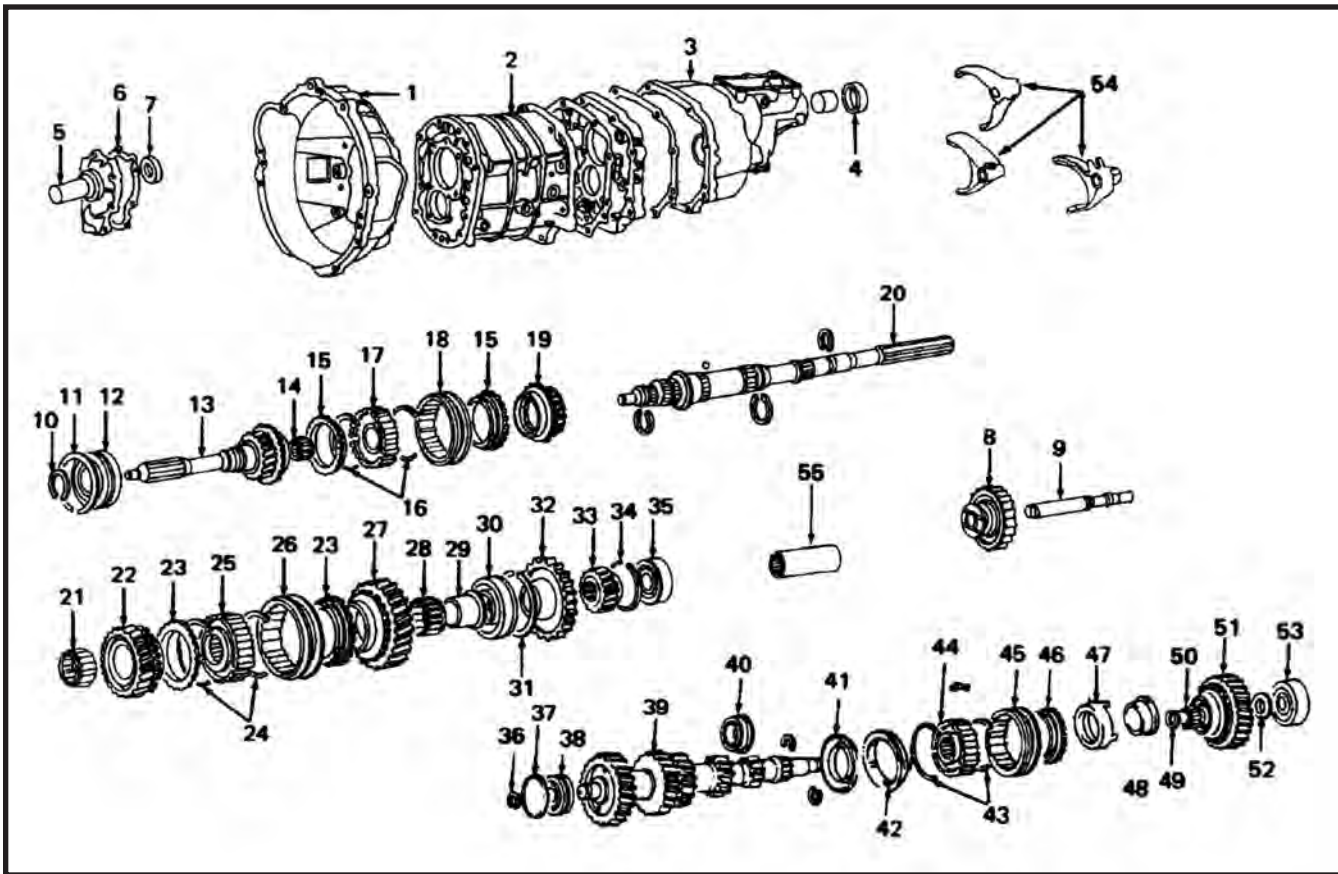

ILL #	MIDWEST #	REF #	REPLACEMENT PART DESCRIPTION
13	W56-16		INPUT 4X4, 1 I.D. GROOVE, 32T, 1984-92
39	W56-8		CLUSTER GEAR 4X4, 47-35-24-13-14, 1984-92
51/33	W56-5		5TH GEAR SET
46	TOY-14		SYNCHRO RING 5TH, 1984-92
15	TOY-14A		SYNCHRO RING 3-4, 1984-92
23	TOY-14B		SYNCHRO RING 1-2, 1984-92
N.I.	W56-55		GASKET SET

KITS

T162R	→	BEARING, GASKET & SEAL KIT, 1984-92
T162RA	→	BEARING, GASKET & SEAL KIT, 1984-92, (HR6307NX BEARING)
T162RB	→	BEARING, GASKET & SEAL KIT, 1992-ON

VW STYLE JETTA/RABBIT

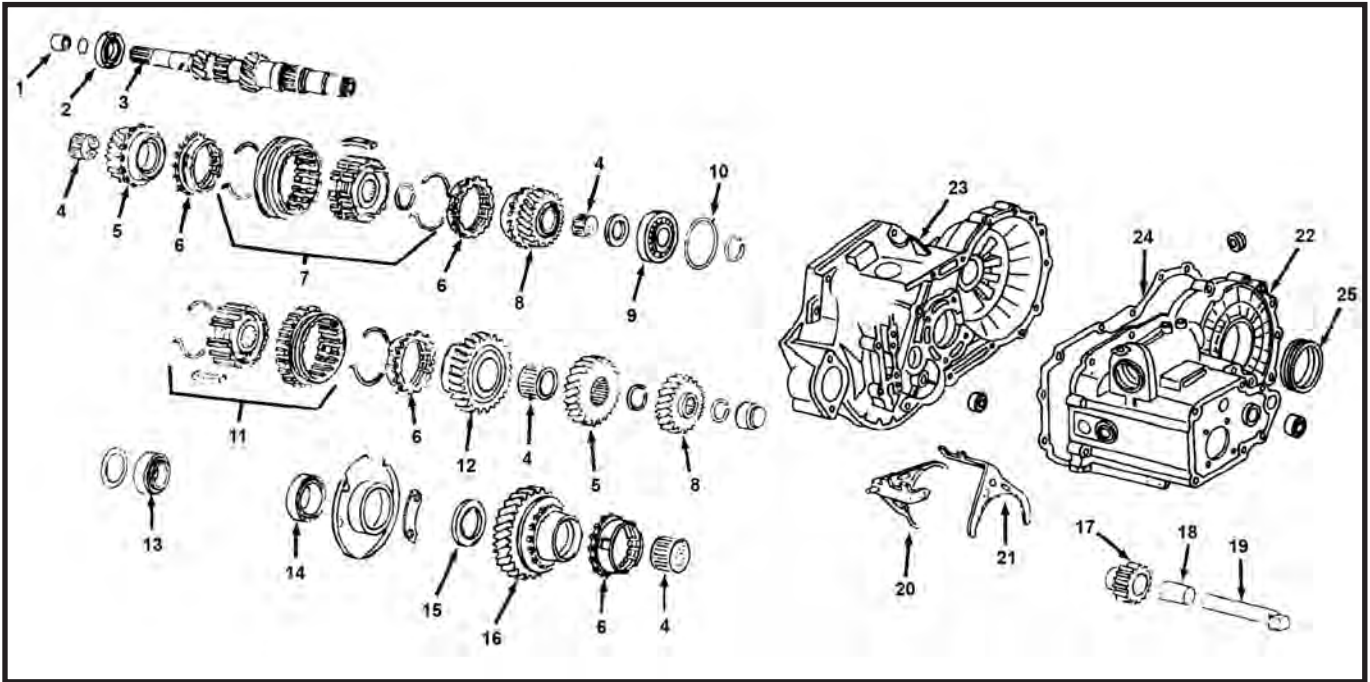

ILL #	MIDWEST #	REF #	REPLACEMENT PART DESCRIPTION
N.I.	VW-5		5TH GEAR SET, 42/47T
17	VW-10		REVERSE IDLER GEAR
11	VW-36		REVERSE GEAR, 1-2 SLIDER, 38T

KITS

T412R	→	BEARING, GASKET & SEAL KIT, 82-ON
-------	---	-----------------------------------

Motive Gear®

TRANSMISSION KIT *REFERENCE GUIDE*

AX5 - STYLE

T160RA	BEARING, SEAL AND GASKET KIT w/ 32BC08S1NR INPUT BRG.
T161LR	BEARING, SEAL AND GASKET KIT w/ SNAP RING ON C/S
T161R	BEARING, GASKET AND SEAL KIT w/ NUT ON C/S
T161RMK	BEARING, GASKET AND SEAL KIT - RING & SMALL PARTS KIT
T161LRMK	BEARING, GASKET AND SEAL KIT - RING AND SMALL PARTS KIT
T160RAMK	BEARING, GASKET AND SEAL KIT - RING AND SMALL PARTS KIT
SPAX5-50	SMALL PARTS KIT
G52-55	GASKET KIT

AX15 - STYLE

T163R	BEARING, SEAL & GASKET KIT
T163RMK	BEARING KIT MASTER REBUILD
T163RAMK	BEARING KIT MASTER REBUILD LATE
RKAX15	RING KIT
RKAX15L	RING KIT LATE
TC2030-12	T/C ADAPTER GASKET

BA10 - STYLE

T219R	BEARING, SEAL AND GASKET KIT
-------	------------------------------

T5 NON-W/C - STYLE

T5R	BEARING, GASKET & SEAL KIT
T5RS	BEARING KIT - SMALL PARTS
T5RMK	BEARING KIT - SMALL PARTS, RINGS, FORK PADS
RK5	SYNCHRO RING KIT
1352410010	GEAR KIT - S-10, JEEP* UPDATE - 007062, 080017
SP5-50	SMALL PARTS KIT
K5	GASKET & SEAL KIT

T5 W/C - STYLE

T5RW	BEARING, SEAL & GASKET KIT
T5RWMK	BEARING KIT - SMALL PARTS, RINGS, FORK PADS
SP5-50W	SMALL PARTS KIT
RK5W	SYNCHRO RING KIT
K5W	GASKET & SEAL KIT

T18 - STYLE

T82AR	BEARING, SEAL & GASKET KIT w/ SMALL PARTS KIT BALL BEARING DESIGN
T82BR	BEARING, SEAL & GASKET KIT w/ SMALL PARTS KIT TAPERED BEARING DESIGN
T82RAMK	BEARING, SEAL & GASKET MASTER KIT w/ RINGS
T82BRMK	BEARING, SEAL & GASKET MASTER KIT w/ RINGS TAPERED BEARING DESIGN
SP18-50	SMALL PARTS KIT
G518-55	GASKET KIT
K82A	GASKET AND SEAL KIT (GAS)
K82B	GASKET AND SEAL KIT (DIESEL)
K82	GASKET AND SEAL KIT (T98)

T19 - STYLE

T82AR19	BEARING GASKET & SEAL KIT - BALL BRG. INPUT
T82BR19	BEARING GASKET & SEAL KIT - TAPERED BRG. INPUT
T82RA19MK	BEARING MASTER KIT, INCLUDE. SMALL PARTS, SYNCHRO RING, SYNCHRO KEYS & SPRINGS
T82BR19MK	BEARING MASTER KIT, INCLUDE. SMALL PARTS, SYNCHRO RING, SYNCHRO KEYS & SPRINGS
K82A	GASKET & SEAL KIT - GAS

TRANSMISSION KIT *REFERENCE GUIDE (cont.)*

T19 - STYLE (cont.)

K82B	GASKET & SEAL KIT - DIESEL
SP19-50	SMALL PARTS KIT
GS19-55	GASKET SET
T19-K1	SYNCHRO KEY & SPRING KIT 1-2
T19-K3	SYNCHRO KEY & SPRING KIT 3-4

A833 - NP440 - MY6 - STYLE

T833R	BEARING GASKET & SEAL KIT - CHRYSLER*/CHEVY TRUCK, O.D.
T833RMK	BEARING GASKET & SEAL MASTER KIT - SMALL PARTS & SYNCHRO RINGS
T833RA	BEARING GASKET & SEAL KIT - CHRYS. CAR NON-O.D., IRON CASE
T833RAMK	BEARING GASKET & SEAL MASTER KIT - SMALL PARTS & SYNCHRO RINGS
T833RB	BEARING GASKET & SEAL KIT - CHRYS. CAR - O.D.IRON OR ALUM.
T833RBMK	BEARING GASKET & SEAL MASTER KIT - SMALL PARTS & SYNCHRO RINGS
K833	GASKET & SEAL KIT - ALL
SP294-50	SMALL PARTS KIT - ALL

M21/M22 - STYLE

T297R	BEARING & SEAL KIT - GM MUNCIE*
T297RA	BEARING & SEAL KIT - 207 INPUT - 1963-64
T297RAMK	BEARING & SEAL MASTER KIT GM* MUNCIE - 1" COUNTER
T297RAHDMK	BEARING & SEAL MASTER KIT - 1" COUNTER MAXI-TYPE BEARINGS - 1966-74
T297RHD	MUNCIE M20, 21, 22 W/ MAXI-TYPE BEARING
T297RHDMK	BEARING & SEAL MASTER KIT - 7/8" COUNTER MAXI-TYPE BEARINGS - 1963-65
T297RMK	BEARING & SEAL KIT - GM MUNCIE* - 7/8" COUNTER
GS297-55	GASKET SET
K297	GASKET/SEAL KIT
SP297-50	SMALL C/S BORE - 1963-65
SP297-50A	LARGE C/S BORE - 1966-74
WT297K	KEY/SPRING KIT

NP435 - STYLE

T127R	BEARING, GASKET & SEAL KIT (TAPERED INPUT)
T127GR	BEARING, GASKET & SEAL KIT (BALL INPUT)
T127RS	BEARING KIT - SMALL PARTS KIT AND FORK INSERTS
T127GRS	BEARING KIT - SMALL PARTS KIT AND FORK INSERTS
T127RMK	BEARING KIT - SMALL PARTS, SYNCHRO RINGS, FORK PADS
T127GRMK	BEARING KIT - SMALL PARTS, SYNCHRO RINGS, FORK PADS
SP291-50	SMALL PARTS KIT
GS291-55	GASKET KIT
K127	GASKET & SEAL KIT

NV1500 - STYLE

T416R	CHEVY, BEARING, GASKET & SEAL KIT
T416RMK	CHEVY, BEARING MASTER KIT
T494R	DODGE, BEARING, GASKET & SEAL KIT
T494RMK	DODGE, BEARING, GASKET & SEAL KIT
RK1500	SYNCHRO RING KIT

NV3500 - STYLE

T235R	BEARING KIT - CHEVY 1988-89 - 2 PC. INPUT AND M/S BEARING
T235RA	BEARING KIT - CHEVY 1989-91 - 2 PC. INPUT AND 1 PC. M/S BEARING
T235RB	BEARING KIT - CHEVY 1991-ON - 1 PC. INPUT AND M/S BEARING
T235RE	BEARING KIT - CHEVY 1996-ON, 200-ON NV3550, 4.0L WRANGLER - LARGER C/S BEARINGS
T235RC	BEARING KIT - DODGE* 1990-ON, 2002-ON NV 3550, 6CYL LIBERTY - 30MM O.D. C/S BEARINGS)
T235RMK	BEARING MASTER KIT- SEE DESCRIPTIONS ABOVE TO I.D.
T235RAMK	BEARING MASTER KIT
T235RBMK	BEARING MASTER KIT
T235RCMK	BEARING MASTER KIT - DODGE* 1990-ON, 2002-ON NV 3550, 6CYL LIBERTY - 30MM O.D. C/S BEARINGS)
T235RDMK	BEARING MASTER KIT 1995-ON (DODGE) THIN INPUT/OUTPUT BRG (0.9") C/S BRGS I.D. (1.18")

TRANSMISSION KIT *REFERENCE GUIDE (cont.)*

NV3500 - STYLE (cont.)

T235REMK	BEARING MASTER KIT
T235RFMK	BEARING MASTER KIT, 2000 UP WRANGLER
T235RGMK	BEARING MASTER KIT 1997-ON (DODGE) w/ 3 PC. RINGS ON 1-2 ASSY ALSO SYNCHRONIZED IN REVERSE
SP3500-50	SMALL PARTS KIT
RK3500DL	SYNCHRO RING KIT- (DODGE) 1997-ON w/ 3 PC. RINGS ON 1-2 ASSY ALSO SYNCHRONIZED IN REVERSE
RK3500	SYNCHRO RING KIT - SINGLE CONE SYNCHRO
RK3500A	SYNCHRO RING KIT - DOUBLE CONE SYNCHRO
RK3500D	SYNCHRO RING KIT- (DODGE) 1993-96 w/ SYNCHRONIZED REVERSE

NV4500 - STYLE

T308R	NV4500 DODGE & CHEVY - NEEDLE
T308RA	NV4500 DODGE & CHEVY - NO NEEDLES
T308RL	NV4500 CHEVY LATE - 1996-LATER - NEEDLE
T308RLA	NV4500 CHEVY LATE - 1996-LATER - NO NEEDLE
T308RMK	NV4500 DODGE & CHEVY - NEEDLE MASTER KIT
T308RAMK	NV4500 DODGE & CHEVY - NO NEEDLE MASTER KIT
T308RLMK	NV4500 CHEVY - 1996-LATER - NEEDLE MASTER KIT
T308RLAMK	NV4500 CHEVY - 1996-LATER - NO NEEDLE MASTER KIT
SP4500-50	SMALL PARTS KIT
SP4500-50A	THRUST WASHER AND SNAP RING KIT
SP4500-50D	SMALL PARTS KIT - COMPLETE DODGE
SP4500-50GM	SMALL PARTS KIT - COMPLETE GM
NV16811K	SHIM KIT M/S
NV16853	SHIM KIT C/S
RK4500	SYNCHRO RING KIT
4882318K	DODGE M/S - 4X4 (INCLUDES SNAP RINGS AND HALF MOONS)
4741468K	DODGE M/S - 2WD (INCLUDES SNAP RINGS AND HALF MOONS)
5013887AA	DODGE DIESEL UPDATED M/S NUT

SM465 - STYLE

T157R	BEARING KIT - 1968-78
T157RL	BEARING KIT - 1979-ON
T157RMK	BEARING KIT - SMALL PARTS - SYNCHRO KEYS & SPRINGS, SYNCHRO RINGS 1968-78
T157RLMK	BEARING KIT - SMALL PARTS - SYNCHRO KEYS & SPRINGS, SYNCHRO RINGS 1979-ON
K157	GASKET & SEAL KIT
SP304-50	SMALL PARTS KIT
GS304-55	GASKET SET
WT304K1	KEY & SPRING KIT - 1-2 SYNCHRO
WT304K3	KEY & SPRING KIT - 3-4 SYNCHRO
WT304-11AX	3RD GEAR KIT - UPDATE - TORQUE-LOCK SYNCHRO TEETH - ANTI JUMP-OUT
WT304-28	SHIFT STICK - IRON COVER
WT304-28A	SHIFT STICK - ALUM. COVER
E8T7220D	SHIFT STICK RETAINER

T10 - STYLE

T10R	BEARING, SEAL & GASKET KIT - T10 - EARLY 1973-DOWN
T10RMK	BEARING, SEAL & GASKET MASTER KIT - EARLY 1973-DOWN
T10WR	BEARING, SEAL & GASKET KIT - SUPER T10, 1974-ON
T10WRMK	BEARING, SEAL & GASKET MASTER KIT - SUPER T10, 1974-ON
K10	SEAL & GASKET KIT
K10W	SEAL & GASKET KIT
GS10-55	GASKET KIT
SP10-50	SMALL PARTS KIT
SP10P-50	SMALL PARTS KIT - 1965-74
SP10W-50	SMALL PARTS KIT - 1974-82

TRANSMISSION KIT *REFERENCE GUIDE (cont.)*

T56 - STYLE

T56R	BEARING, GASKET & SEAL KIT
T56RMK	BEARING MASTER KIT - 1 PC. RINGS 3-4-5-6
T56RAMK	BEARING MASTER KIT - 3 PC. RINGS
RK56	SYNCHRO RING KIT - 1 PC. RINGS 3-4-5-6
RK56A	SYNCHRO RING KIT - 3 PC. RINGS
SP56-50	SMALL PARTS KIT - 1 PC. RINGS 3-4-5-6
SP56-56A	SMALL PARTS KIT - 3 PC. RINGS
1386000011	TRANS ASSY - RETROFIT F-BODY - REPLACES T5
1386000012	TRANS ASSY - RETROFIT MUSTANG - REPLACES T5

G360 - STYLE

T261R	BEARING KIT
RK360	SYNCHRO RING KIT
PTO-55	PTO COVER GASKET

NP535 - STYLE

T535R	BEARING, SEAL & GASKET KIT
T535RMK	BEARING, SEAL & GASKET MASTER KIT - RINGS
RK535	RINGS - ALL
SP535-50	SMALL PARTS KIT
4338302	FRONT GASKET

NV5600 - STYLE

T492R	BEARING GASKET & SEAL KIT
T492RAMK	BEARING GASKET & SEAL MASTER KIT w/ RINGS - EARLY DESIGN
T492RMK	BEARING GASKET & SEAL MASTER KIT w/ RINGS

FM145 / FM146 / FM132 - STYLE

T50R	BEARING, SEAL & GASKET KIT - FM145 / FM146
T50RMK	BEARING, SEAL & GASKET MASTER KIT w/ RINGS - FM145
T50RAMK	BEARING, SEAL & GASKET MASTER KIT - FM146
T50RB	BEARING, SEAL & GASKET KIT - FM132
T50RBMK	BEARING, SEAL & GASKET MASTER KIT w/ RINGS - FM132
MIT-55	GASKET KIT
RK50	SYNCHRO RING KIT FM145
RK50A	SYNCHRO RING KIT FM146
K50	GASKET & SEAL KIT

M5R1 - STYLE

T247R	BEARING, GASKET & SEAL KIT
T247RMK	MASTER BEARING KIT - SYNCHRO RINGS, NON-UPDATED
T247RAMK	MASTER BEARING KIT - SYNCHRO RINGS, UPDATED
K247	GASKET & SEAL KIT
M5R1-K3	SYNCHRO KEY & SPRING KIT 1-2, 3-4
M5R1-SK	INPUT SHAFT SHIM KIT
M5R1-REVKIT	REVERSE GEAR KIT - NON-UPDATED (INCLUDES REV. GEAR, SLIDER, SYNCHRO RING)
RKL-M5R1	REVERSE GEAR KIT - UPDATED (INCLUDES REVERSE GEAR, SLIDER, SYNCHRO RING)
RK247	SYNCHRO RING KIT - NON-UPDATED
RK247A	SYNCHRO RING KIT - UPDATED
FK-M5R1	FRONT REPAIR KIT
FKT-M5R1	FK-M5R1 - PLUS TOP COVER SHIFT PINS, RAIL PLUGS, SHIFTER SEATS
F0T27C391D	5-REV. SYNCHRO UPDATE KIT (GENUINE FORD® PARTS) - 4.0 ENGINE
F0T27C391C	5-REV. SYNCHRO UPDATE KIT (GENUINE FORD PARTS) -2.9 /3.0 ENGINE

TRANSMISSION KIT *REFERENCE GUIDE (cont.)*

M5R2 - STYLE

T248R	BEARING, GASKET & SEAL KIT
T248RMK	BEARING KIT - SYNCHRO RINGS - NON-UPDATED 5-REV.
T248RAMK	BEARING KIT - SYNCHRO RINGS - UPDATED 5-REV.
K248	GASKET & SEAL KIT
RK248	SYNCHRO RING KIT - NON-UPDATED 5-REV.
RK248A	SYNCHRO RING KIT - UPDATED 5-REV.
M5R2-K3	SYNCHRO KEY & SPRING KIT 1-2 & 3-4
M5R2-REVKIT	REVERSE GEAR KIT (INCLUDES REVERSE GEAR, SLIDER, RING) NON-UPDATED
RKL-M5R2	REVERSE GEAR KIT (INCLUDES REVERSE GEAR, SLIDER, RING) UPDATED
FK-M5R2	FRONT REPAIR KIT
FKT-M5R2	SAME AS ABOVE - TOP COVER SHIFTER BUSHINGS AND WELCH PLUGS
FOTZ7C391E	5-REV. UPDATED KIT (GENUINE FORD® PARTS)
M5R2-SK	INPUT SHIM
NK248	NEEDLE BEARING KIT

S5-42 / S5-47 - STYLE

T300ZR	BEARING, SEAL & GASKET KIT w/ NEEDLES
T300ZRA	BEARING, SEAL & GASKET KIT w/o NEEDLES
RK1307/RK1317	S5-42/47 RING KIT (GENUINE)
ZF42-SK/ZF47-SK	S5-42/47 RING KIT (BRONZE AFTERMARKET)
ZF42-SKS/ZF47-SKS	S5-42/47 RING KIT (STEEL w/ BRASS REV. AFTERMARKET)
1307PPK	S5-42/47 PRESSURE PIECE KIT
1307RBK	S5-42/47 SMALL PARTS KIT
1307SRK	S5-42/47 SNAP RING KIT
1307SMK	S5-42/47 SHIM KIT

S5-47M - STYLE

T300ZR	BEARING, SEAL & GASKET KIT w/ NEEDLES
T300ZRA	BEARING, SEAL & GASKET KIT w/o NEEDLES
RK1317	SYNCHRO RING KIT (GENUINE)
ZF47-SK	SYNCHRO RING KIT (BRONZE/AFTERMARKET)
ZF47-SKS	SYNCHRO RING KIT (STEEL w/ BRASS REV. / AFTERMARKET)
1317PPK	PRESSURE PIECE KIT
1307RBK	SMALL PARTS KIT
1307SRK	SNAP RING KIT
1307SMK	SHIM KIT

S6-650 - STYLE

T1319R	BEARING, SEAL & GASKET KIT w/ NEEDLES
T1319RA	BEARING, SEAL & GASKET KIT w/o NEEDLES
1319PPK	PRESSURE PIECE KIT
1319SK	SYNCHRO RING KIT (GENUINE)
ZFS6-SKS	SYNCHRO RING KIT (STEEL w/ BRASS REV. / AFTERMARKET)
1319RBK	SMALL PARTS KIT
1319SMK	SHIM KIT
1319SRK	SNAP RING KIT

T45 MUSTANG - STYLE

T520R	BEARING KIT - ALL
T520RMK	BEARING MASTER KIT - INCLUDES RINGS
RK45	SYNCHRO RING KIT
SP45-50	SMALL PARTS KIT
K520	GASKET & SEAL KIT

TRANSMISSION KIT *REFERENCE GUIDE (cont.)*

TREMEC T170 - STYLE

T170R	BEARING KIT - FORD® CAR
T174R	BEARING KIT - FORD TRUCK
T175R	BEARING KIT - JEEP®
GS170-55	GASKET SET FORD CAR / FORD TRUCK / JEEP
GS173-55	GASKET SET
GS296-55	GASKET SET - HEH FORD CAR
K170	GASKET/SEAL KIT - FORD CAR
K174	GASKET/SEAL KIT - FORD TRUCK
K175	GASKET/SEAL KIT - JEEP
SP170-50	SMALL PARTS KIT - FORD CAR/TRUCK
SP176-50	SMALL PARTS KIT - JEEP
SP296-50	SMALL PARTS KIT - HEH FORD CAR
T170K1	KEY/SPRING KIT 1-2 SYNCHRO
T170K3	KEY/SPRING KIT 3-4 SYNCHRO

TOYO KOGYO - RANGER 5 SPEED - STYLE

T12R	BEARING, GASKET & SEAL KIT
T12RMK	BEARING, GASKET, SEALS, AND RING KIT
T12RAMK	BEARING, GASKET, SEALS, AND LATE RING KIT
K12	GASKET & SEAL KIT

TREMEC TR3550/TKO - STYLE

T3550R	BEARING KIT
T3550RMK	MASTER BEARING KIT
2671136	FRONT SHIFT CONVERSION KIT
2671127	MID-SHIFT CONVERSION KIT
M6392R58	BELL HOUSING - FORD® MUSTANG APPLICATION - ALUM.
M6392C	SCATTERSHIELD 1979-93 MUSTANG APPLIC. - STEEL
M5059A	ADJUSTABLE CROSS MEMBER 1979-93 MUSTANG
8625	MCLEOD BELLHOUSING 289, 302, 351 - TREMEC 3550 ADAPT.
8655	MCLEOD BELLHOUSING SB CHEVY, BUICK®, OLDSMOBILE®, PONTIAC® V8 - 1962-92 - TREMEC 3550 ADAPTER (NO HYD. SLAVE CYL. BRACKET)
8610	MCLEOD ADAPTER TREMEC 3550 TRANS TO 17 DEGREES, T-5 BELLHOUSING
8607	MCLEOD ADAPTER TREMEC 3550 TO STANDARD CHEVY BELLHOUSING
5055	PRO 5.0 SHORT THROW SHIFTER - 3550 ADAPTER
RK3550	SYNCHRO RING KIT

TREMEC TR3650 - STYLE

T255R	BEARING & SEAL KIT
T255RMK	MASTER BEARING, SEAL & GASKET KIT w/RINGS

ZF - STYLE PARKING BRAKE

T300BDR	BEARING & SEAL KIT
6051001035	ELECTRIC SPEEDO / w/o HOLE
6051001036	MECHANICAL SPEEDO - w/ HOLE

HONDA® - A2Q6 - STYLE

T238R	BEARING, GASKET & SEAL KIT - 8 BOLT COVER, 5TH GEAR
-------	---

ISUZU® TRUCK - STYLE

T220R	BEARING, SEAL AND GASKET KIT 7/87-92
T220RA	BEARING, SEAL AND GASKET KIT 92-ON - 3-PIECE, 5-REV. SYNCHROS HAVE DIFFERENT INSIDE TAPER
T220RB	BEARING, SEAL AND GASKET KIT 98-ON - 1-2 RINGS, 3-PIECE, 5-REV. SYNCHROS HAVE SAME INSIDE TAPER

TRANSMISSION KIT *REFERENCE GUIDE (cont.)*

MITSUBISHI® - D50 - STYLE

T139R	BEARING, SEAL & GASKET KIT - INPUT BEARING TMSC0788N
T304R	BEARING, SEAL & GASKET KIT - V6 - 10/91-ON
T310R	BEARING, SEAL & GASKET KIT - INPUT F6307X-1-1
T415R	BEARING, SEAL & GASKET KIT - INPUT BEARING 307L - DOUBLE BALL ON M/S
T510R	BEARING, SEAL & GASKET KIT - INPUT 307L - SINGLE BALL ON M/S
D50-55	GASKET SET

NISSAN® RS5F30A, 31A - STYLE

	**BEARING, SEAL & GASKET KIT	
T714R	- PULSAR:	82-86 RS5F30A (1.6L)
	- SENTRA:	82-83 RN4F30A/RN5F30A (1.5L)
		82-87 RN4F30A/RN5F30A (1.6L)
		82-86 RN4G30/RN5F30A (1.7L) DIESEL
	**BEARING, SEAL & GASKET KIT	
T213R	-PULSAR:	82-86 RS5F31C (1.5L)
		87-90 RS5F31A (1.6L)
	-SENTRA:	88-90 RN4F31A (1.6L)
		86-90 RS5F31A (1.6L)
	-STANZA:	81-86 RS5F31A (2.0L)

NISSAN® FS5R30A (V6) - STYLE

	**BEARING, SEAL & GASKET KIT
T240R	-PATHFINDER: 86-ON FS5R30A (3.0L, 3.3L, 3.5L)
	-FRONTIER: 2000-ON FS5R30A (3.3L)
	-HARDBODY: 86-95 FS5R30A (3.0L)
	-300ZX: 87-96 FS5R30A (3.0L) (ALL)
	**BEARING, SEAL & GASKET KIT WITH RINGS
T240WX	-PATHFINDER: 86-87 FS5R30A (3.0L) (1-2 RING = 42T)
	-HARDBODY: 86-87 FS5R30A (3.0L) (1-2 RING = 42T)
T240RLMK	-PATHFINDER: 87-92 FS5R30A (3.0L) (1-2 RING = 54T)
	-HARDBODY: 87-92 FS5R30A (3.0L) (1-2 RING = 54T)
	-300ZX: 86-89 FS5R30A (TURBO) (1-2 RING = 54T)
T240RCMK	-PATHFINDER: 92-98 FS5R30A (3.0L, 3.3L) (2-3 RING = MULTIPIECE)
	-HARDBODY: 92-95 FS5R30A (3.0L), (2-3 RING = MULTIPIECE)
	-300ZX: 89-96 FS5R30A (3.0L) (TWIN & NON-TURBO) (2-3 RING = MULTIPIECE)
T240RDMK	-PATHFINDER: 98-02 FS5R30A (3.3L, 3.5L) (3-4 RING = 74.95mm I.D.)
	-FRONTIER: 00-ON FS5R30A (3.3L NON-SUPERCHARGED) (3-4 RING = 74.95mm I.D.)

NISSAN® FS5W71 - STYLE

	**BEARING, SEAL & GASKET KITS
T104R	-200SX: 80-84 FS5W71C 2WD (2.0L, 2.2L)
T313R	-200SX: 84-86 FS5W71C 2WD (1.8L) (TURBO)
	-200SX: 84-88 FS5W71C 2WD (2.0L)
	-200SX: 87-88 FS5W71C 2WD (3.0L)
	-240SX: 88-97 FS5W71H 2WD (2.4L)
T133RE	-240SX: 93-97 FS5W71H 2WD (2.4L) (POCKET NDL. BEARING - 31mm)
T104R	-280Z: 77-78 FS5W71A 2WD (2.8L)
	-280ZX: 79-83 FS5W71A 2WD (2.8L)
T313R	-300ZX: 83-89 FS5W71C 2WD (3.0L)
T173R	-510: 78-81 FS5W71C 2WD (1.8L)
T104R	-720 SERIES: 74-84 2WD / 4X4 FS5W71A, C (2.0L)
T313R	-720 SERIES: 84-86 2WD / 4X4 FS5W71C (2.4L, 2.5L)
T104R	-810: 79-81 FS5W71A, C 2WD (2.4L, 2.8L DIESEL)
T122RE	-FRONTIER: 98-00 FS5W71C 4X4 (2.4L)
T133RE	-FRONTIER: 98-ON FS5W71C 2WD (2.4L)
T313R	-HARDBODY: 86-97 FS5W71E 2WD (2.4L, 2.5L)
T122R	-HARDBODY: 86-89 FS5W71G 4X4 (2.4L) (RR. C/S BEARING = BALL TYPE)
T122RA	-HARDBODY: 90-96 FS5W71G 4X4 (2.4L) (RR. C/S BEARING = ROLLER TYPE)
T122RE	-HARDBODY: 96-98 FS5W71G 4X4 (2.4L) (POCKET NDL. BEARING = 31mm)
T104R	-MAXIMA: 82-84 FS5W71C (2.4L, 2.8L DIESEL)

TRANSMISSION KIT *REFERENCE GUIDE (cont.)*

NISSAN® FS5W71- STYLE (cont.)

	**BEARING, SEAL & GASKET KITS (cont)
T122R	-PATHFINDER: 86-88 FS5W71G (2.4L)
T313R	-VAN: 87-90 F4W71E, 2WD
T133RE	-XTERRA: 00-ON FS5W71C (2.4L) 2WD
T122RE	-XTERRA: 00-ON FS5W71G 4X4 (2.4L)
	**BEARING, SEAL & GASKET KITS (W/RINGS)
T104RMK	-200SX: 80-84 FS5W71C, 2WD (2.0L, 2.2L) (ALL RINGS SAME SIZE AND TYPE)
T313RAMK	-200SX: 84-86 FS5W71C, 2WD (1.8L) (TURBO)
	-200SX: 84-88 FS5W71C, 2WD (2.0L) (2ND SYNCHRO RING = 1 PC.)
	-200SX: 87-88 FS5W71C, 2WD (3.0L)
T313RBMK	-200SX: 1988 FS5W71, 2WD (2.0L, 3.0L) (2ND SYNCHRO RING = 2 PC.)
T313RCMK	-240SX: 93-97 FS5W71H, 2WD (2.4L)
T104RAMK	-280Z: 77-78 FS5W71A, 2WD (2.8L) (FIBER STYLE 5TH RING NOT INCLUDED)
	-280ZX: 79-80 FS5W71A, 2WD (2.8L) (FIBER STYLE 5TH RING NOT INCLUDED)
T104RMK	-280ZX: 80-83 FS5W71A, 2WD (2.4L, 2.8L DIESEL) (5TH RING = BRASS)
T313RAMK	-300ZX: 83-87 FS5W71C, 2WD (3.0L)
T313RBMK	-300ZX: 87-88 FS5W71C, 2WD (3.0L) (2ND SYNCHRO RING = 2 PC.)
T104RMK	-720 SERIES: 80-82 FS5W71C, 2WD / 4X4 (2.2L) (FRT. C/S BRG. = 60mm)
	-720 SERIES: 82-84 FS5W71C, 2WD / 4X4 (2.0L, 2.4L, 2.5L) (FRT. C/S BRG. = 60mm OD)
T313RMK	-720 SERIES: 84-86 FS5W71C, 2WD / 4X4 (2.0L, 2.4L, 2.5L) (FRT. C/S BRG. = 61mm OD)
T104RAMK	-810: 79-80 FS5W71A, 2WD (2.0L) (FIBER STYLE 5TH RING NOT INCLUDED)
T122REMK	-FRONTIER: 98-00 FS5W71C, 4X4 (2.4L)
T313RAMK	-HARDBODY: 88-89 F4W71E, 2WD (2.4L) (4 SPEED)
T313RAMK	-HARDBODY: 86-83 FS5W71E, 2WD (2.4L)
T313RAMK	-HARDBODY: 86-93 FS5W71E, 2WD (2.5L) (DIESEL)
T313RBMK	-HARDBODY: 93-95 FS5W71E, 2WD (2.4L) (2ND SYNCHRO RING = 2 PC.)
T313RCMK	-HARDBODY: 1996 FS5W71E, 2WD (2.4L) (2ND SYNCHRO RING = 2 PC.)
T313RDMK	-HARDBODY: 1997 FS5W71E, 2WD (2.4L) (SINGLE PC. RINGS + REV. SYNCHRO RING)
T122RMK	-HARDBODY: 86-89 FS5W71G, 4X4 (2.4L) (RR. C/S BRG. = BALL TYPE)
T122RAMK	-HARDBODY: 90-92 FS5W71G, 4X4 (2.4L) (RR. C/S BRG. = ROLLER TYPE)
T122RBMK	-HARDBODY: 92-93 FS5W71G, 4X4 (2.4L) (INCLUDES REV. SYNCHRO RING)
T122RCMK	-HARDBODY: 93-96 FS5W71G, 4X4 (2.4L) (INCLUDES REV. SYNCHRO RING)
T122REMK	-HARDBODY: 96-98 FS5W71G, 4X4 (2.4L) (POCKET NDL. BRG. - 31mm)
T122RMK	-PATHFINDER: 86-88 FS5W71G (2.4L)
T313RAMK	-VAN: 87-90 F4W71E, 2WD (2.4L) (4 SPEED)
T122RFMK	-XTERRA: 2000-ON FS5W71G, 2WD
T313RGMK	-XTERRA: 2000-ON FS5W71G, 4X4

G52 - STYLE

T161R	BEARING, SEAL AND GASKET KIT w/ 32TM03 OR 32BC54 INPUT BEARING
T161TR	BEARING, SEAL AND GASKET KIT w/ B32TM03X OR 32BC58-2MT2N INPUT BEARING
T610R	BEARING, SEAL AND GASKET KIT w/ B32-144R OR 32BC08SIN INPUT BEARING
RKAX5	SYNCHRO RING KIT
G52-55	GASKET KIT

L52 - STYLE

T100R	BEARING, SEAL & GASKET KIT w/ B32-144R OR 32 BC08S1N INPUT BEARING
T100RMK	BEARING, SEAL & GASKET MASTER KIT w/ B32-144R OR 32 BC08S1N INPUT BEARING
T101R	BEARING, SEAL & GASKET KIT w/ 032-2 ROLLER INPUT BEARING
T101RMK	BEARING, SEAL & GASKET MASTER KIT w/ 032-2 ROLLER INPUT BEARING
T715R	BEARING, SEAL & GASKET KIT w/ 63-32 BALL INPUT BEARING
T715RMK	BEARING, SEAL & GASKET MASTER KIT w/ 63-32 BALL INPUT BEARING
RKAX5	SYNCHRO RING KIT
GS101-55	GASKET SET

TOYOTA® W56 - STYLE

T162R	BEARING, GASKET & SEAL KIT, 1984-92
T162RA	BEARING, GASKET & SEAL KIT, 1984-92, (HR6307NX BEARING)
T162RB	BEARING, GASKET & SEAL KIT, 1992-ON

VW - JETTA/RABBIT - STYLE

T412R	BEARING, GASKET & SEAL KIT, 82-ON
-------	-----------------------------------

UNMATCHED

durability • power • performance

“...We had run 3 UROC Pro National events, featuring the most grueling obstacles in rock crawling history, without a drop of fluid in the diffs...When we found the problem we only had time to add oil. They continued to work so well that we completed the rest of the 2005 UROC Pro National Series and Super Crawl IV in Las Vegas! **Motive Gears have got to be THE TOUGHEST GEARS available, I wouldn't run anything else!**”

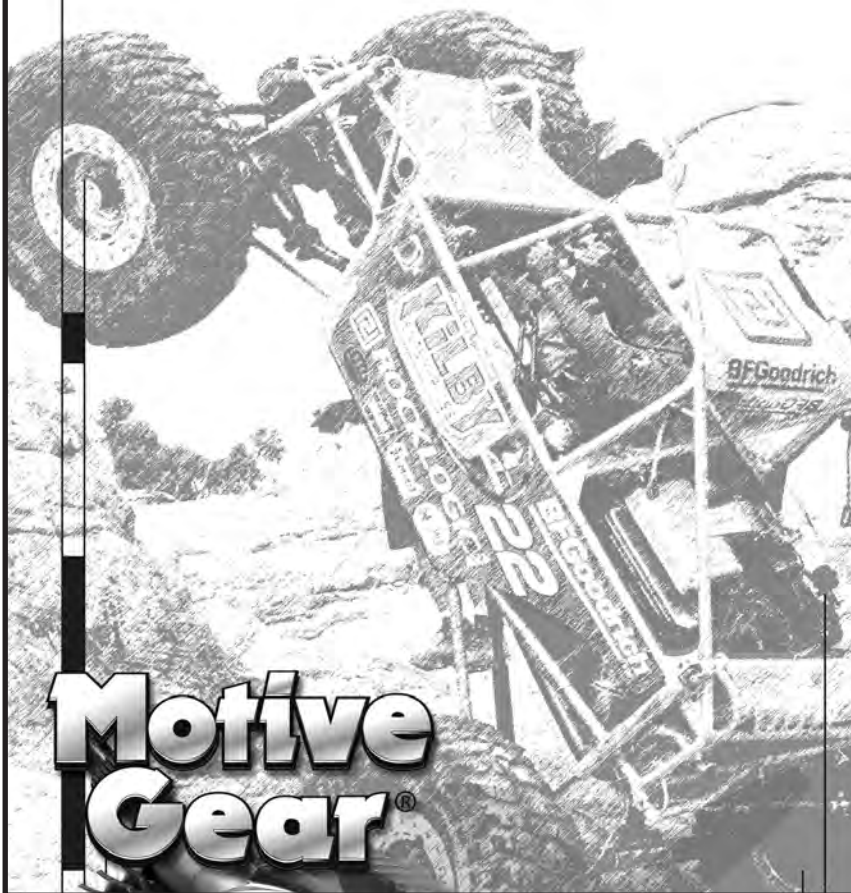

NP208 STYLE

SYNCHRONIZED

DODGE® 100-350 1982-1987
GM® K10/20, V10/25 1981-88

NON-SYNCHRONIZED

DODGE® 100/350 1980-82
FORD® BRONCO 1980-86, F150/350
JEEP® 1980-88

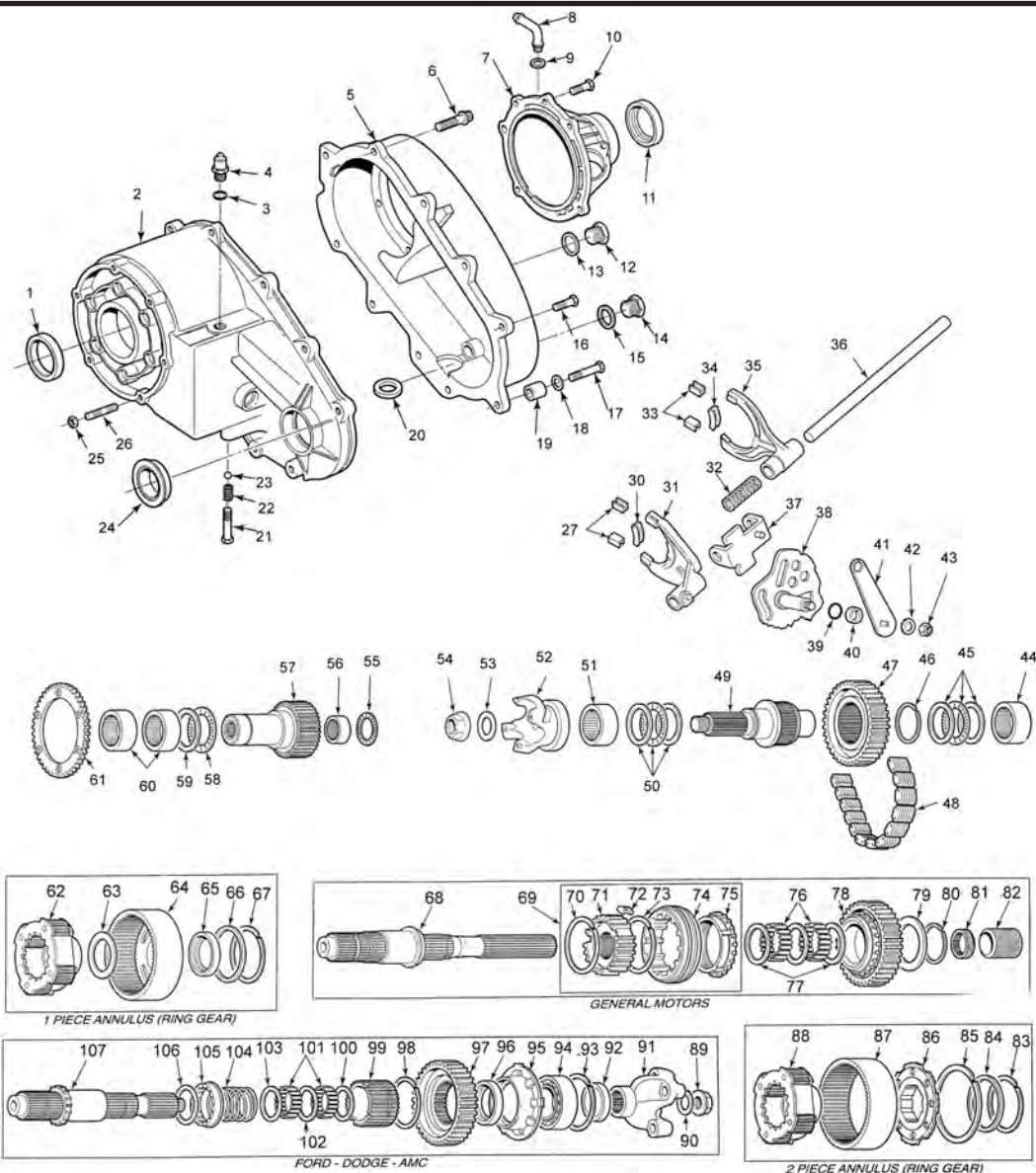

ILL #	MIDWEST #	REF #	REPLACEMENT PART DESCRIPTION
1	3173		SEAL, INPUT (2 PCS)
2	15166		FRONT CASE HALF - CHEVY
2	NV13684		FRONT CASE HALF - AMC*
2	4167927		FRONT CASE HALF - DODGE*
3	3515027		GASKET - SWITCH HOLE
4	4168000		SWITCH - AMC, DODGE, FORD*
4	14037986		SWITCH - CHEVY
5	15079C		REAR CASE HALF - CHEVY
5	NV13685		REAR CASE HALF - AMC
5	E0T27005A		REAR CASE HALF - FORD
6	8130979		BOLT, CASE ASSY
7	NV13692		REAR RETAINER - AMC
7	4219093		REAR RETAINER - DODGE* 1980-82, FORD NON-SYNCHRONIZED

NP208 STYLE (cont.)

ILL #	MIDWEST #	REF #	REPLACEMENT PART DESCRIPTION
7	14037990		REAR RETAINER - CHEVY 1981-86 SYNCHRONIZED
8	8130985		CONNECTOR - VENT TUBE
9			SEAL - VENT TUBE CONNECTOR
10	4210617		BOLT, REAR RETAINER
N.I.	WT297-62		BUSHING, REAR OUTPUT
11	3946		SEAL, REAR OUTPUT - FIXED YOKE
11	4333N		SEAL, REAR OUTPUT - SLIP YOKE
11	9449		SEAL, REAR OUTPUT - CHEVY
14/12	4210616		PLUG, DRAIN & FILL (INCLUDE. GASKET)
15/13	N.S.S.		GASKET, FILL & DRAIN PLUG - MOST PURCHASE PLUG
17	4210614		BOLT, CASE ASSY - DOWEL
18	4210983		WASHER, ALIGNMENT DOWEL BOLT
19	14037948		ALIGNMENT DOWEL
20	3681601		MAGNET, CHIP COLLECTOR
21	4213355		SCREW, SHIFT POPPET
22	1798192		SPRING, POPPET PLUNGER
23	4037956		PLUNGER, POPPET
24	3946		SEAL, FRONT OUTPUT
25			NUT, FRONT MOUNTING STUD
26	4167922		STUD, FRONT MOUNTING
30	4167970		FORK PAD, RANGE CENTER
31	15111C	C13731	SHIFT FORK, RANGE (USES FORK PADS) 1980-81 FORD*, JEEP*
31	15380		SHIFT FORK, RANGE (NO FORK PADS) 1983-90 FORD, JEEP
31	4167966R		SHIFT FORK, RANGE - CHEVY SYNCHRONIZED 1981-86 & 1980-82 DODGE*
32	4167975		SPRING, MODE FORK
33/27	4167969		FORK PAD, TIPS - RANGE/MODE
34	4219073		FORK PAD, MODE CENTER
35	4219070		SHIFT FORK, MODE - CHEVY - ALL, DODGE SYNCHRONIZED 1982-83
35	4167974		SHIFT FORK, MODE - AMC*, DODGE 1980-82, FORK
35	4329518		SHIFT FORK, MODE - DODGE SYNCHRONIZED 1984-87 (USES PADS)
36	4167965		SHIFT RAIL - ALL
37	4219075		BRACKET, MODE FORK
38	NV13722		SECTOR ASSY - AMC, FORD*
38	4219066		SECTOR ASSY - CHEVY, DODGE SYNCHRONIZED
39	4167963		O-RING - SECTOR SHAFT SEAL
40	4167964		RETAINER - SECTOR SHAFT O-RING
41	4167970 / 13722		LEVER - SHIFT
42			WASHER - SHIFT LEVER NUT
43			NUT - SHIFT LEVER RETAINING
44	SCE2416		BEARING, FRONT OUTPUT - REAR
46	4167991		SNAP RING, DRIVEN SPROCKET
47	4269178		DRIVEN SPROCKET, FORD
47	15307		DRIVEN SPROCKET, CHEVY
48	HV014		CHAIN - DODGE, GM 1/2" PITCH X 1-1/4" W X 72 PITCHES
49	4167730		SHAFT, FRONT OUTPUT - 61T, 1.36" O.D., 32 SPL., 1981-86 ALL
49	8130976		SHAFT, FRONT OUTPUT 1980-90 JEEP
50/45	TC2840		NEEDLE BEARING, THRUST
51	SCE2816		BEARING, FRONT OUTPUT - FRONT
52	CALL		YOKE - CALL WITH APPLICATION
53	4210973		WASHER, OUTPUT YOKE
54	4167924		NUT, OUTPUT YOKE
55	4269182		NEEDLE BEARING, MAIN SHAFT THRUST
56	SCE2012		NEEDLE BEARING, INPUT POCKET
57	4167935		INPUT SHAFT - AMC, DODGE 46T, 5-5/65" O.A., 23 SPL.
57	13779		INPUT SHAFT - FORD* 46T, 5-5/16" O.A., 1980-86 NON-SYNCHRONIZED
57	13948		INPUT SHAFT - CHEVY 46T - 350, 700 SERIES, 27 SPL.
57	15112		INPUT SHAFT - CHEVY 46T - 400 SERIES, 32 SPL.
58	AXK5070		NEEDLE BEARING, INPUT THRUST
59	4329189		THRUST WASHER
60	HK5020NFC		NEEDLE BEARING, INPUT (2 REQ.)
61	4167931		PLATE - LOW RANGE LOCK
62			SEE #88
63	4167953		THRUST WASHER
64	4167954		ANNULUS/RING GEAR

NP208 STYLE (cont.)

ILL #	MIDWEST #	REF #	REPLACEMENT PART DESCRIPTION
65	4167958		BUSHING - ANNULUS
66	4167959		THRUST WASHER
67	3821372		SNAP RING
69	4219080		SYNCHRONIZER ASSY - CHEVY- ALL, DODGE 1982-83
69	4329516		SYNCHRONIZER ASSY - DODGE 1984-ON
70/73	4329524		SPRING, SYNCHRONIZER (2 REQ.)
71	N.S.S.		HUB, SYNCHRO (SEE #69)
72	NV15213		SYNCHRO KEY (3 REQ.)
74	N.S.S.		SYNCHRO SLEEVE - NOT SOLD SEPARATELY
75	4219082		SYNCHRO BLOCKING RING
75	4329526		SYNCHRO BLOCKING RING, DODGE 1984-ON
76	C1086Q		NEEDLE BEARING, SPROCKET (120 REQ.)
77	4219088		SPACER, NEEDLE BEARINGS
79	4329330		THRUST WASHER, SPROCKET
80	4167987		SNAP RING, DRIVE SPROCKET
81	3894957		OIL PUMP GEAR
82	NV13943		SPEEDO GEAR, 18T DRIVE - BLUE, CHEVY
82	14037997		SPEEDO GEAR, 1ST DRIVE - BROWN, CHEVY
82	4210606		SPEEDO GEAR, DODGE
82	NV13172		SPEEDO GEAR, 8T DRIVE - FORD
82	NV11392		SPEEDO GEAR, 7T DRIVE - FORD
83	3821372		LOCK RING, WEB AND HUB TO SHAFT
84	4219064		THRUST WASHER, WEB AND HUB
85	4219065		LOCK RING, WEB AND HUB
86	4295115		ANNULUS CLUTCH, WEB AND HUB ASSY
87	4219060		ANNULUS RING (w/o CLUTCH)
88/62	4329198R		PLANETARY ASSY
89	4167924		NUT, M/S YOKE
90	4210973		WASHER, YOKE
91	CALL		YOKE, MAIN SHAFT REAR - CALL - APPLICATION
93	4210984		SNAP RING, MAIN SHAFT REAR BEARING
94	207		BEARING, MAIN SHAFT REAR
95	NV15486		OIL PUMP HOUSING
96	4210603		OIL SEAL, PUMP
97/78	4269178		DRIVE SPROCKET, NON-SYNCHRONIZED
97/78	4219087		DRIVE SPROCKET, SYNCHRONIZED
98	4167984		SNAP RING, SPROCKET CARRIER
99	4269214		SPROCKET CARRIER
101	C1086Q		NEEDLE BEARING, SPROCKET CARRIER
103/102/100	4167985		SPACER, NEEDLE BEARINGS
104	4167979		SPRING, MODE CLUTCH
105			MODE CLUTCH GEAR -SOLD W/ MAINSHAFT 4329194
106	4269177		THRUST WASHER
107/68	4329194		MAIN SHAFT - AMC, DODGE, FORD 52-16-38, 32T, 14 23/6 O.A.
107/68	16036		MAIN SHAFT - CHEVY1981-86 SYNCHRONIZED
107/68	4329329		MAIN SHAFT - DODGE, SYNCHRONIZED 52-38, 32T, 14.36 O.A.
124	HV012		CHAIN - FORD, 1/2" PITCH X 1-1/4" W X 84 PITCHES
N.I.	3894957		PUMP HOUSING GEAR (PLASTIC)

KITS

T212R	→ BEARING SEAL & GASKET KIT
SP208-50	→ SMALL PARTS KIT
K208	→ GASKET/SEAL KIT

AMC® NV219 STYLE JEEP® 1980-1984

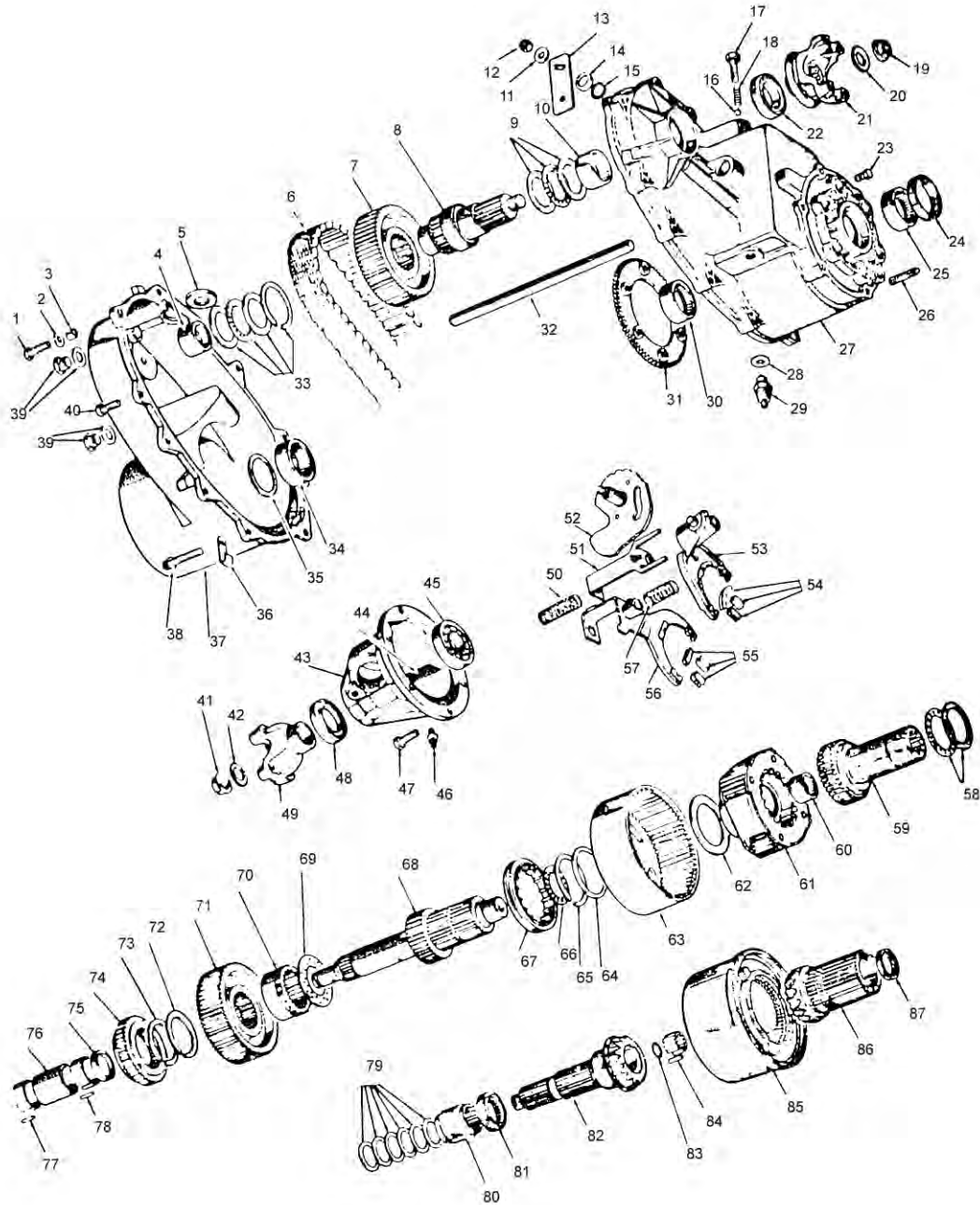

ILL #	MIDWEST #	REF #	REPLACEMENT PART DESCRIPTION
1	4269183	8130870	OIL SEAL, CASE INPUT
3	4167922	8130805	STUD, CASE ADAPTER (2 REQ.)
4	NV13684	8130867	CASE, FRONT HALF
5	3515027	8130830	GASKET, LOCKOUT SWITCH
6	NV15087	8132843	SWITCH, LOCKOUT
7/2	4269185	8130868	BEARING, INPUT SHAFT (2 REQ.)
8	NV13728	8130873	PLATE, LOCKOUT
9	NV15006	8130838	RAIL, SHIFT
11	3821391	8130835	BEARING, REAR OUTPUT INNER
12	3521390	8130834	WASHER, REAR OUTPUT INNER BEARING
13	NV13118	8130980	CLIP, WIRING
14	NV13687	8130833	CASE, REAR HALF

AMC® NV219 STYLE (cont.)

ILL #	MIDWEST #	REF #	REPLACEMENT PART DESCRIPTION
15	NV15107	8130979	BOLT
16	4210616	8130824	PLUG ASSEMBLY (2 REQ.)
17	NV61574	8130810	BOLT, CASE HALF (6 REQ.)
18	4210614	8130825	BOLT, CASE HALF DOWEL (2 REQ.)
19	4210983	G120394	WASHER, DOWEL BOLT (2 REQ.)
20	NV13687	8130872	DOWEL, HALF CASE (2 REQ.)
21	4269189	8130836	BEARING, FRONT OUTPUT SHAFT REAR
22	3681601	8130823	MAGNET
23	HV015	8130831	CHAIN, 98 LINKS 1-3/4" WIDE
24/80	NV15451	8130849	SPROCKET, DRIVE & DRIVEN 61T (.375 X 1.75W) (2 REQ.)
25	NV15336	8130850	SHAFT, FRONT OUTPUT
26/10	NV15127	8130819	BEARING ASSEMBLY, FRONT OUTPUT SHAFT (2 REQ.)
27	4269186	8130869	BEARING, FRONT OUTPUT FRONT
28	4210983	G120394	WASHER
29	NV13992	8130813	NUT, LEVER
30	NV15155	8130811	LEVER
31	4167964	8130853	RETAINER, O-RING
32	4167963	8130854	O-RING, SECTOR SHIFT SHAFT
33	147487	8130855	BALL, POPPET SPRING
34	4210613	8130857	SCREW
35	1798192	8130856	SPRING, SHIFT SECTOR POPPET
38	NV13776	8130818	YOKE FRONT OUTPUT INCL. NUT & WASHER
40	NV13903	8130874	BOLT, LOW RANGE PLATE (6 REQ.)
41/42	4167969	8130859	PAD, SHIFT FORK (2 REQ.)
43	15111C	8130858	FORK RANGE
44	NV15008	8130852	SECTOR, RANGE
45	NV13951	8130837	BRACKET, MODE
46	NV13952	8130839	SPRING, MODE BRACKET
47	NV13816	8130861	SPRING, FRONT MODE FORK
48	NV13965	8130860	FORK FRONT MODE
49	NV15104	8130985	VENT
50	4120617	8130984	BOLT, REAR RETAINER (6 REQ.)
51/39	4412990	8130808	OIL SEAL, REAR OUTPUT SHAFT FRONT & REAR OUTPUT (2 REQ.)
52	NV13775	8130817	YOKE ASSEMBLY, REAR INCL. NUT & WASHER
53/37	4210973	8130815	WASHER (2 REQ.)
54/36	4167924	8130816	NUT (2 REQ.)
55	NV13693	8130806	RETAINER, REAR
56	NV11930	8130809	SEAL, VENT CHAMBER
57	NV15646	8130807	BEARING, REAR OUTPUT OUTER
58/83	3821366	8130848	SPACER (2 REQ.)
59	NV15002	8130845	GEAR, SIDE
60	13855	8130800	VISCOUS ASSEMBLY
61	NV15129	8130804	ROLLER PILOT BEARING
62	3821353	8130843	SEAL, O-RING
63	NV13867	8130803	SHAFT, REAR OUTPUT
64	NV15460	8133645	PUMP, OIL
65	4210606	8130827	GEAR, SPEEDO DRIVE
66	NV15128	8130828	SHIM KIT
67	4329189		WASHER, INPUT GR. THRUST
67	4167934	8130875	BEARING, INPUT GR. THRUST
68	4167935	8130877	GEAR, DRIVE 23 SPL. 46T 5-5/64L
69	4269187	8130878	BEARING, PILOT
70	4167941	8130862	PLANETARY ASSEMBLY, COMPLETE - CAN USE 4329198
71	4167953	8130863	WASHER, INPUT GR. THRUST 3-7/16" O.D. 1/16T
72	4167954	8130864	ANNULUS & CLUTCH ASSEMBLY
73	4167959	8130865	WASHER, THRUST 2-21/32" I.D.
74	3821372	8130866	RING, ANNULUS & CLUTCH RETAINING 2-5/8 ID 3" O.D.
75	4269182	8130879	WASHER, MAIN SHAFT THRUST
76	NV13834	8130840	SLEEVE, FRONT SLIDING MODE
77	NV15001	8130842	MAIN SHAFT
78	NV13851	8130844	WASHER, MAIN SHAFT THRUST
79	NV15003	8130841	GEAR, MODE CLUTCH SIDE
81	4167991	8130802	RING, SPROCKET RETAINING (3 REQ.)
82	NV13854	8130801	GEAR, VISCOUS CLUTCH
84	NV15004	8130847	SPACER
85	666927	8130846	ROLLER, SPROCKET CARRIER 1/8" O.D. 15/16L (82 REQ.)

AMC® NV219 STYLE (cont.)

KITS

T229R	→	BEARINGS, GASKETS, SEALS
K208	→	GASKETS, SEALS, O-RINGS

AMC® NV228 & NV229 STYLE 1981-91 JEEP®

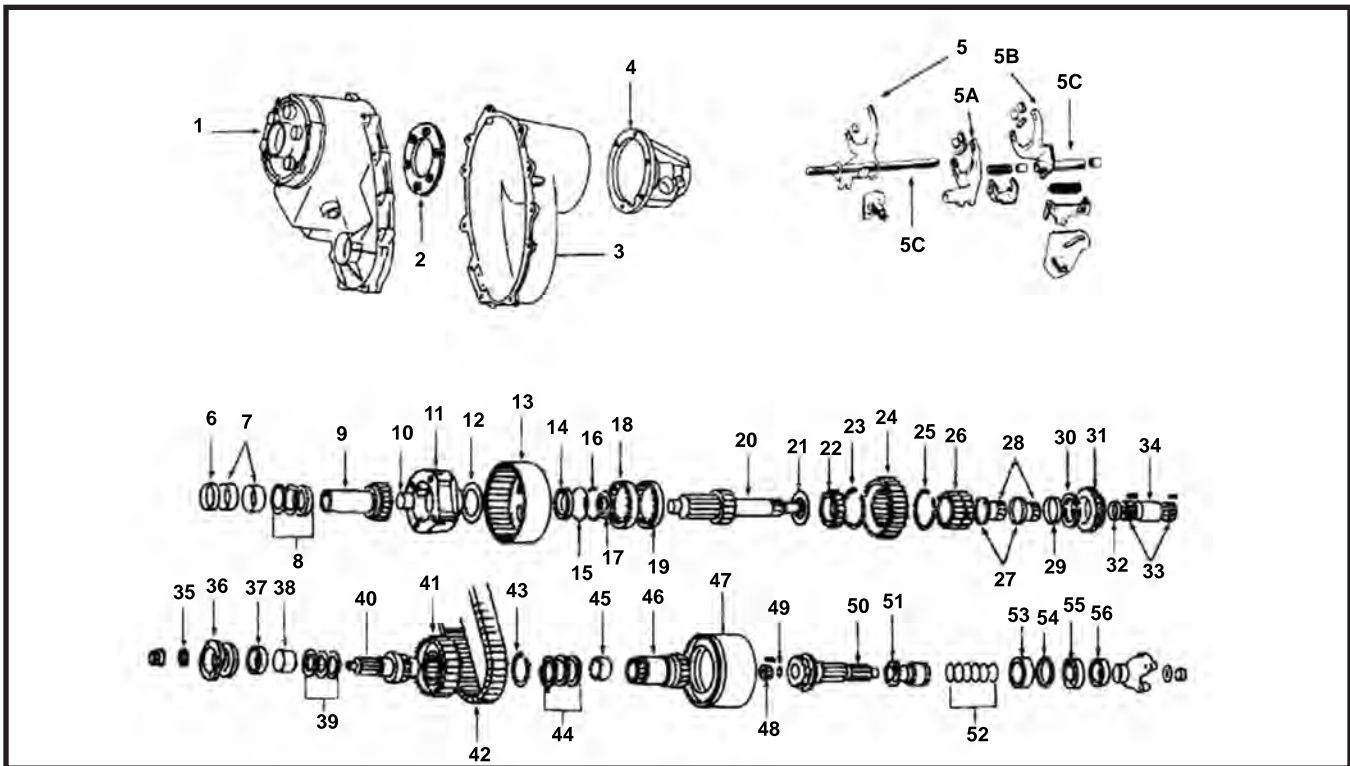

ILL #	MIDWEST #	REF #	REPLACEMENT PART DESCRIPTION
1	NV13684	8130867	CASE, FRONT HALF
N.I.	3515027	8130830	GASKET, LOCKOUT SWITCH
N.I.	15087	8132843	SWITCH, LOCKOUT
3	NV13687	8130833	CASE, REAR HALF
4	NV13693	8130806	RETAINER, REAR
5		8134276	FORK, RANGE
5A		8134287	FORK, LOCKING
5B		8134307	FORK, MODE
5C	NV15006	8130838	RAIL, SHIFT
N.I.	4167969		FORK PAD, TIPS, 2 PER
N.I.	4167970		FORK PAD, CENTER
6	4269183	8130870	OIL SEAL, CASE INPUT
N.I.	4167922	8130805	STUD, CASE ADAPTER (2 REQ.)
7	4269185	8130868	BEARING, INPUT SHAFT (2 REQ.)
8	AXK5070	16027	BEARING ASSY, INPUT THRUST
9	NV15786	83500492	SHAFT, INPUT - 46T, 23 SPL. 5" O.A., 1.25" I.D., 1981-91
10	SCE2012	8130878	BEARING, DRIVE GEAR
11	4329198R	8983500383	PLANETARY, COMPLETE 1981-91
12	4167953	8130863	WASHER, INPUT GEAR THRUST - 3.44" O.D., 2.65" I.D., .071" THICK
13	4167954	8130865	ANNULUS & CLUTCH ASSY - BUSHING, 1981-91 - ALL
14	NV13721	8133677	BUSHING, ANNULUS
17	3521390	8130834	WASHER, REAR OUTPUT INNER BEARING
18	16112C	8983502516	SLEEVE SERRATED TEETH, NO LIP
19	16111	8983502611	SLEEVE STRAIGHT TEETH, LIP
20	NV15636	8134274	MAIN SHAFT 52T - 16-35 SPL., 1.49" O.D., 1981-91 - ALL
21	13851	8130844	WASHER, MAIN SHAFT THRUST - 3.05" O.D., 1.75" I.D., .03" THICK
22	NV15283	8133633	GEAR, SIDE GEAR CLUTCH - 16 EXTENSION TEETH
23	4167984	8130970	RING, RETAINING
23/25	13842	8131613	WASHER, SPROCKET THRUST
24	NV15450	8131610	SPROCKET - 46 EXTENSION TEETH, 32T
26	NV15285	8133632	CARRIER - 16T - 3.253" O.D., 2.525" I.D.
28	3508004	8131611	ROLLERS, CARRIER (120 REQ.)
N.I.	4269182	8130879	WASHER, THRUST - 2.16" O.D., 1.57" I.D., .07" THICK
N.I.	3821372	8130866	RING, ANNULUS & CL. RETAINING - .85" THICK, 2.8" O.D., 2.44" I.D.
29	13841	8131612	SPACER

AMC® NV228 & NV229 STYLE (cont.)

ILL #	MIDWEST #	REF #	REPLACEMENT PART DESCRIPTION
N.I.	4210983	G120394	WASHER
N.I.	NV13992	8130813	NUT, LEVER
N.I.	NV15155	8130811	LEVER
N.I.	4167964	8130853	RETAINER, O-RING
N.I.	4167963	8130854	O-RING, SECTOR SHIFT SHAFT
N.I.	147487	8130855	BALL, POPPET SPRING
N.I.	4210613	8130857	SCREW
N.I.	1798192	8130856	SPRING, SHIFT SECTOR POPPET
32	3821366	8130848	SPACER - .30" THICK, 1.7265" O.D., 1.535" I.D.
N.I.	13854	8130801	GEAR, VISCOUS CLUTCH
34	15004	8130847	SPACER - 1.97" O.A., 1.75" O.D., 1.52" I.D.
N.I.	C1086Q	8130846	ROLLER, SIDE GEAR (82 REQ.)
35	4210973	8130815	WASHER (2 REQ.)
35	4210973	8130815	WASHER
N.I.	4167924	8130816	NUT (2 REQ.)
N.I.	4167924	8130816	NUT
N.I.	13775	8130817	YOKE, REAR (INCL. NUT AND WASHER)
37	4167735	8130808	SEAL (MODEL 229) (2 REQ.)
N.I.	4210617	8130810	BOLT, RETAINER (6 REQ.)
N.I.	15491	8133743	SEAL, VENT
38/45	4269189	8130836	BEARING, FRONT OUTPUT SHAFT REAR
N.I.	3681601	8130823	MAGNET
40	NV15336	8130850	SHAFT, FRONT OUTPUT
N.I.	13776	8130818	YOKE FRONT OUTPUT INCL. NUT & WASHER
N.I.	13903	8130874	BOLT, LOW RANGE PLATE (6 REQ.)
41	NV15451	8130849	SPROCKET, 61T (.375 X 1.75W) (2 REQ.)
42	NV15027	8130831	CHAIN, 98 LINKS 1-3/4" WIDE
45	4167959	8130865	WASHER, THRUST - .06" THICK, 2.95" O.D., 2.65" I.D.
46	NV13836	8131608	GEAR, SIDE - 16T - 61-52 SPL., 4.18" O.A., 1.75" I.D.
47	NV13843	83502517	VISCOUS, COUPLING ASSEMBLY (MODEL 228) 4.378" O.D., 1.43" I.D., 10T - 35 SPL. X 4 GRs.
47	NV13855	8130800	VISCOUS, COUPLING ASSEMBLY (MODEL 228)
48	QAR29523	8130804	ROLLERS, PILOT BEARING (15 REQ.)
49	3821353	8130843	SEAL, O-RING
50	NV13867	8130803	SHAFT, REAR OUTPUT - 16T, 38-32 SPL., 1.36" O.D.
51	4446463	8133645	PUMP, OIL
51	NV13728	8130873	PLATE, LOCKOUT
52	15128	8130828	SHIM KIT
53	3821391	8130835	BEARING, REAR OUTPUT INNER
N.I.	13118	8130980	CLIP, WIRING
N.I.	15107	8130979	BOLT
N.I.	4210616	8130824	PLUG ASSEMBLY (2 REQ.)
N.I.	61574	8130810	BOLT, CASE HALF (6 REQ.)
N.I.	4210614	8130825	BOLT, CASE HALF DOWEL (2 REQ.)
N.I.	4210983	G120394	WASHER, DOWEL BOLT (2 REQ.)
N.I.	13687	8130872	DOWEL, HALF CASE (2 REQ.)
N.I.	NV15461	8133646	GEAR, SPEEDO DRIVE - 38 SPL.10 THREADS, 1.99" O.D.1.65" I.D.

KITS

T229R	→ BEARING KIT
SP208-50	→ SMALL PARTS KIT
K208	→ GASKETS, SEALS, O-RING
12442	→ ASSEMBLY, 229

NV242J/DHD STYLE

SELEC-TRAC™

JEEP® WRANGLER/CHEROKEE 1987-02

DODGE® DURANGO/DAKOTA 1997-ON

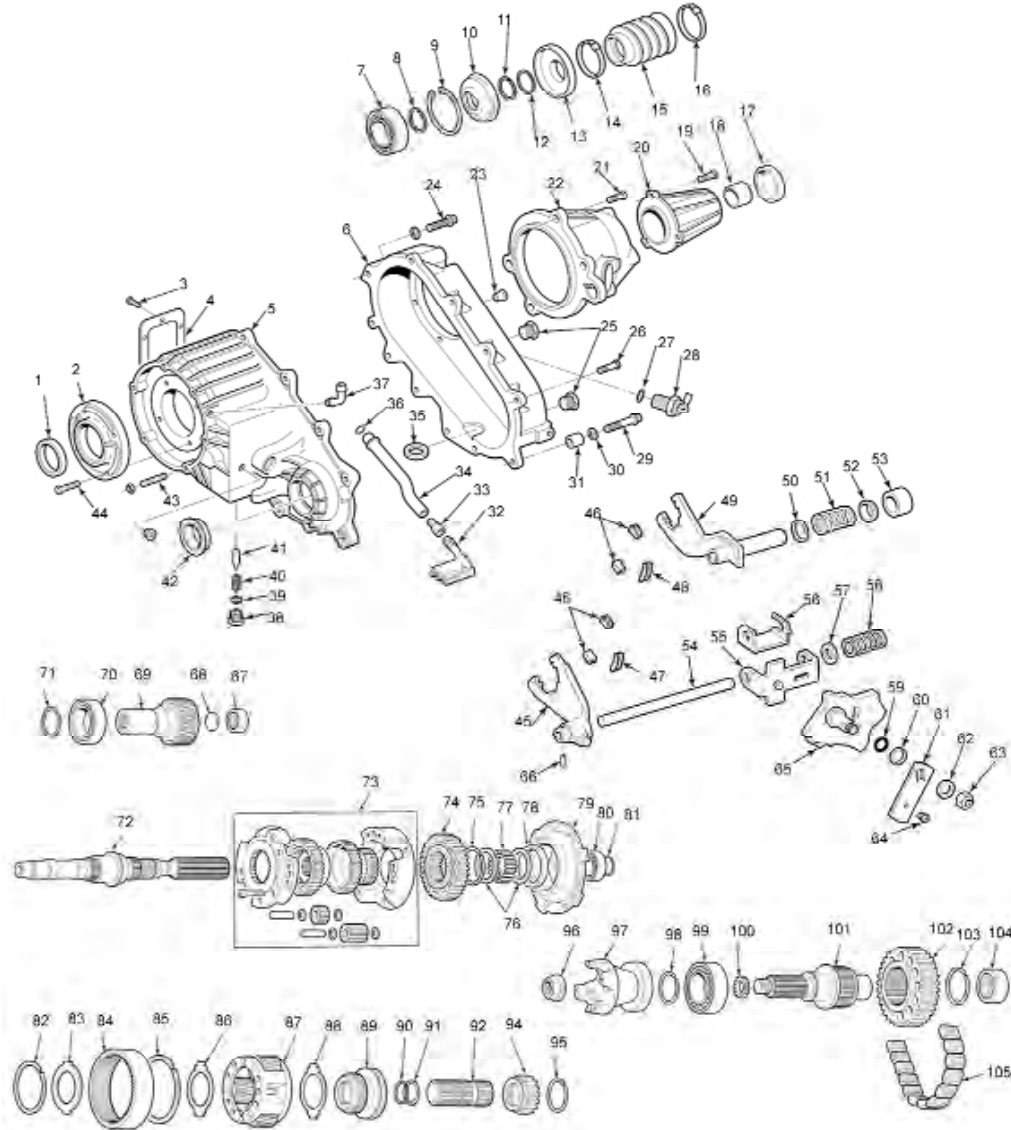

ILL #

MIDWEST #

REF #

REPLACEMENT PART DESCRIPTION

1	3173		SEAL - INPUT
1	710928		SEAL - INPUT - DODGE*
2	NV16187	4338972	RETAINER - FRONT BEARING
3			BOLT - PTO COVER
4			COVER - PTO
5	NV17034	83503500	FRONT CASE HALF - CHEROKEE 1987-93, COMANCHE, WAGONEER - ALL
5	NV17938	4796979	FRONT CASE HALF - CHEROKEE 1994-96
5	NV24401	4883336	FRONT CASE HALF - CHEROKEE 1997-01, GRAND CHEROKEE 1997-98 V6
5	NV17357	4638947	FRONT CASE HALF - GRAND CHEROKEE 1993
5	NV17940	4796971	FRONT CASE HALF - GRAND CHEROKEE 1994-96
5	NV19115	4856389	FRONT CASE HALF - GRAND CHEROKEE 1997-98 - V8
5	NV26398	5003439AA	FRONT CASE HALF - GRAND CHEROKEE 1999
5	NV30154	5014045AA	FRONT CASE HALF - GRAND CHEROKEE 2000-02
5	NV311997	5015828AA	FRONT CASE HALF - DODGE*
5	NV32736	5072315AA	FRONT CASE HALF - LIBERTY 2002
6	NV16476	4886373AA	REAR CASE HALF - CHEROKEE, COMANCHE, WAGONEER - ALL, GRAND CHEROKEE - (EXC. BELOW)

NV242J/DHD STYLE (cont.)

ILL #	MIDWEST #	REF #	REPLACEMENT PART DESCRIPTION
6	5013858AA		REAR CASE HALF - GRAND CHEROKEE, 2000-2002 - V8
6	5072303AA		REAR CASE HALF - LIBERTY 2002
7	206		BEARING - REAR OUTPUT
8	8134488		SNAP RING
9	4798116		RETAINING RING - REAR BEARING
10	4798119		SLINGER, WASHER
11	8134488		SNAP RING
12	4798118		WASHER
13	4798119		SLINGER - WASHER
14	4798121		CLAMP
15	4798123		BOOT
16	4798122		CLAMP
17	3946	1900044012	SEAL - REAR OUTPUT - DODGE
17	4370N	4638904	SEAL - REAR OUTPUT
18	NV16081	8134490	BUSHING - REAR EXTENSION
19/21	4210617		SCREW - REAR RETAINER
20	NV16222	83503156	REAR EXTENSION - WAGONEER, COMANCHE - ALL, CHEROKEE 1987-96, GRAND CHEROKEE 1993-98
20	4338973		REAR EXTENSION - CHEROKEE 1997-2000, DODGE - ALL
22	NV16463	83503524	REAR RETAINER - WAGONEER, COMANCHE - ALL, CHEROKEE 1987-96
22	NV19126	4856391	REAR RETAINER - CHEROKEE 1997-2001, GRAND CHEROKEE 1997-98
22	5012347AA		REAR RETAINER - CHEROKEE 1999-2000 / 2001-2002 V6
22	5003456AA		REAR RETAINER - GRAND CHEROKEE 2001-02 - V8
22	5072305AA		REAR RETAINER - LIBERTY 2002
22	4638955		REAR RETAINER - GRAND CHEROKEE 1993-96
23	NV16458	4638953	DOWEL - RETAINER ALIGNMENT
25	NV15054	4210606	PLUG - FILL/DRAIN - (2 REQ.)
28			SWITCH - CALL WITH TAG#
29	4210614		SCREW - DOWEL
29	4210617		SCREW - CASE FLANGE
30	NV13627	4116310	DOWEL, ALIGNMENT
32	NV16217	4338943	SCREEN - OIL
33	NV16218	4338944	CONNECTOR - OIL SCREEN
34	NV16252	83503523	TUBE, OIL
35	95472	3681601	MAGNET
36	NV16214	4338942	O-RING, OIL TUBE
37			BREATHER BARB
38	NV16756	53008216	SCREW, POPPET
39	NV15715	4338956	O-RING, POPPET PLUG
40	NV17071	4638497	SPRING, POPPET PLUNGER
41	NV16754	53008217	PLUNGER, POPPET
42	1900044012		SEAL - FRONT OUTPUT
43	NV15053	4167922	STUD - FRONT MOUNTING
44	6500318		SCREW - FRONT RETAINER
45	NV16472	83503508	FORK, RANGE - ALL
45	NV31199	5015831AA	FORK, RANGE SHIFT, DODGE
45	NV21222		IRON
46	4167969		FORK PADS (4 REQ.) - TIPS
47	4338376		FORK PAD (1 REQ.) - RANGE CENTER
48	4219073		FORK PAD (1 REQ.) - MODE CENTER
49	NV16460	83503509	FORK, MODE - COMANCHE 1987-1990, WAGONEER 1987-90, ALL - CHEROKEE 1987-96
49	4638950		FORK, MODE - CHEROKEE 1997-2001, GRAND CHEROKEE, LIBERTY - ALL, DODGE
50	NV16456	83503512	WASHER
51	NV16453	83503513	SPRING
52	NV15624	8134291	BUSHING
53	NV16459		SLEEVE
54	NV16449	83504469	RAIL - SHIFT
55	NV16474	83503510	BRACKET, OUTER
56	NV16310	83503511	BRACKET, INNER
56	NV16447	83503515	CUP, SPRING
58	NV16446	83503516	SPRING
59	4167963		SEAL - SHIFT SHAFT - O-RING
60	4167964		RETAINER - O-RING
61	53004227		LEVER - SHIFT
62	4001104		WASHER - SHIFT SHAFT
63	8130813		NUT - SHIFT SHAFT
64	53004810		BUSHING, SHIFT LEVER

NV242J/DHD STYLE (cont.)

ILL #	MIDWEST #	REF #	REPLACEMENT PART DESCRIPTION
65	NV16279	83503503	SHIFT SECTOR
66	8133636	91386	ROLL PIN, RANGE FORK
67	FC66561	83503507	NEEDLE BEARING, INPUT POCKET
68	NSS		PLUG - INPUT
69	NV16761	53006082	INPUT - JEEP® WAGONEER, COMANCHE - ALL, CHEROKEE 1987-90, 21 SPL.
69	4636792		INPUT - JEEP CHEROKEE, GRAND CHEROKEE 1991-93, 23 SPL.
69	4796980		INPUT - JEEP CHEROKEE 1994-96
69	4798126		INPUT - JEEP CHEROKEE 1997-2001, GRAND CHEROKEE 1997-98, 23 SPL, 53T
69	4796972		INPUT - JEEP GRAND CHEROKEE 1994-96
69	5003446AA		INPUT - JEEP GRAND CHEROKEE 1999-2002, (EXC. BELOW)
69	5012311AA		INPUT - JEEP GRAND CHEROKEE 2001-2002 - V8
69	5072298AA		INPUT - JEEP LIBERTY 2002
69	5015491AA		INPUT - DODGE® 1998-2000 DAKOTA/DURANGO
70	BD50-8		BEARING - INPUT TO 1994 - WIDE
70	6010NR		BEARING - INPUT 1994-ON - THIN
71	3821558		SNAP RING
72	83503528		MAIN SHAFT - JEEP COMANCHE, WAGONEER - ALL CHEROKEE, GRAND CHEROKEE 1987-96
72	4798145		MAIN SHAFT - JEEP CHEROKEE/GRAND CHEROKEE 1997-2000
72	5016620AA		MAIN SHAFT - JEEP CHEROKEE 2001
72	5016614AA		MAIN SHAFT - JEEP GRAND CHEROKEE 2000-2002, (EXC. BELOW)
72	5003448AA		MAIN SHAFT - JEEP GRAND CHEROKEE 2000-2002 - V8
72	5072299AA		MAIN SHAFT - JEEP LIBERTY
72	5003448AA		MAIN SHAFT - DODGE DAKOTA, DURANGO 1998-2000
73/26	NV16470	83503529	DIFF. ASSY - WAGONEER, COMANCHE, CHEROKEE - ALL, GRAND CHEROKEE - ALL - (EXC. BELOW)
73/26	5003449AB		DIFF. ASSY - GRAND CHEROKEE 2001-2002 - V8
73/26	5072300AA		DIFF. ASSY - LIBERTY 2002
74	83503531		SPROCKET DRIVE - (EXC. BELOW)
74	83503536		SPROCKET DRIVE - GRAND CHEROKEE V8, LIBERTY
74	5015833AA		SPROCKET DRIVE - DODGE DAKOTA, DURANGO
75			SNAP RING
76			WASHER
77	Q8308		NEEDLE BEARING - DIFF. ASSY
78	4210603	341022	OIL SEAL - PUMP
79	4338936		OIL PUMP ASSY - ALL (EXC. BELOW)
79	4883596AA		OIL PUMP ASSY - LIBERTY 2002
80	206		BEARING, M/S REAR
80	207XLO		BEARING - REAR OUTPUT - DODGE
81	8134488		SNAP RING, M/S REAR BEARING
82	4338910		SNAP RING
83	4338909		LOCK RING - PLANETARY
84	83503122		ANNULUS GEAR
85	4219065		LOCK RING - ANNULUS
86			SEE ITEM #88
87	4338901		PLANETARY ASSY - JEEP® 1988, CHEROKEE, COMANCHE, WAGONEER 1987-88
87	53006087	16551	PLANETARY ASSY - JEEP 1989-96, CHEROKEE, COMANCHE 1993-96, GRAND CHEROKEE, WAGONEER 1989-90
87	4796903AB		PLANETARY ASSY - JEEP 2002, GRAND CHEROKEE
88/86	4338908		THRUST WASHER
89	83503541		RANGE SLEEVE - JEEP 1987-88, CHEROKEE, COMANCHE, WAGONEER
89	83506203		RANGE SLEEVE - JEEP 1989-90 (SAME AS ABOVE)
89	53006090		RANGE SLEEVE - JEEP 1991-96, CHEROKEE, GRAND CHEROKEE
89	4798279		RANGE SLEEVE - JEEP® 1997-2002, (EXC. BELOW)
89	NV21400	5003746AA	RANGE SLEEVE - JEEP 1999-2002, GRAND CHEROKEE 6 CYL. LIBERTY, DODGE®
90	83903540		SNAP RING - RANGE SLEEVE
91	83503539		WASHER - RANGE SLEEVE
92	83503538		SHAFT - INTERMEDIATE - JEEP 1987-96
92	4798277		SHAFT - INTERMEDIATE - JEEP 1997-ON, GRAND CHEROKEE AND LIBERTY 2002
94	83503542		SLEEVE - MALE SHIFT
N.I.	5015835AA		SLEEVE - MODE SYNCHRO - DODGE
95	83503537		SNAP RING - MODE SLEEVE
96	4167924		NUT, YOKE
N.I.	4210973		WASHER, YOKE NUT
97	4798138		YOKE, FRONT OUTPUT JEEP CHEROKEE, WAGONEER,

NV242J/DHD STYLE (cont.)

ILL #	MIDWEST #	REF #	REPLACEMENT PART DESCRIPTION
97	5012308AA		COMANCHE - ALL, GRAND CHEROKEE 1993-98 YOKE, FRONT OUTPUT - JEEP GRAND CHEROKEE 1999-2000/2001 V6 (EXC. BELOW)
97	5019514AA		YOKE, FRONT OUTPUT - JEEP GRAND CHEROKEE 2000-ON V8
97	5066927AA		YOKE, FRONT OUTPUT - LIBERTY 2002
98	89331A		SNAP RING
99	207L		BEARING - FRONT OUTPUT
99	207XLO		BEARING - FRONT OUTPUT - DODGE, JEEP 1997-ON
100			SEAL - YOKE SPLINE
101	83503517		SHAFT - FRONT OUTPUT - CHEROKEE, COMANCHE, WAGONEER 1987-01 - ALL, GRAND CHEROKEE 1993, 1997-98
101	4746321		SHAFT - FRONT OUTPUT - GRAND CHEROKEE 1994-96
101	5012336AA		SHAFT - FRONT OUTPUT - GRAND CHEROKEE 1999-ON,
102	83503518		SPROCKET DRIVEN - JEEP* - (EXC. BELOW)
102	NV26408	5003452AA	SPROCKET DRIVEN - JEEP GRAND CHEROKEE V8 2001-2002
102	5012322AB		SPROCKET DRIVEN - JEEP LIBERTY
102	NV26408	5003452AA	SPROCKET DRIVEN - DODGE DAKOTA, DURANGO
103	4167991		RETAINING RING
104	SCE2416	4269189	NEEDLE BEARING, FRONT OUTPUT PILOT
105	HV028		CHAIN - DODGE, JEEP 1/2" PITCH X 1" WIDE X 72 PITCHES
105	HV063		CHAIN - DODGE, JEEP - V8 3/8" PITCH X 1-1/4" WIDE X 98 PITCHES
105	HV060		CHAIN - HUMMER .5033 PITCH X 1-1/4" WIDE X 72 PITCHES
105	HV061		CHAIN - JEEP EUROPE XJ & ZJ - .5033 PITCH X 1" WIDE X 72 PITCHES
105	HV062		CHAIN - JEEP LIBERTY SELECT TRAC, 2002-ON, 3/8" PITCH X 1" WIDE X 72 PITCHES

KITS

T242R	→	BEARING, GASKET & SEAL KIT - EARLY JEEP TO 1994
T242RL	→	BEARING, GASKET & SEAL KIT - LATE JEEP 1994-ON, 110L INPUT BEARING
T242RHD	→	BEARING, GASKET & SEAL KIT - DODGE
K242	→	GASKET & SEAL KIT - EARLY JEEP TO 1994
K242A	→	GASKET & SEAL KIT - DODGE
K242B	→	GASKET & SEAL KIT - LATE JEEP 1994-ON
SP242-50B	→	SMALL PARTS KIT

NV247/249J STYLE

JEEP® GRAND CHEROKEE 1992-02

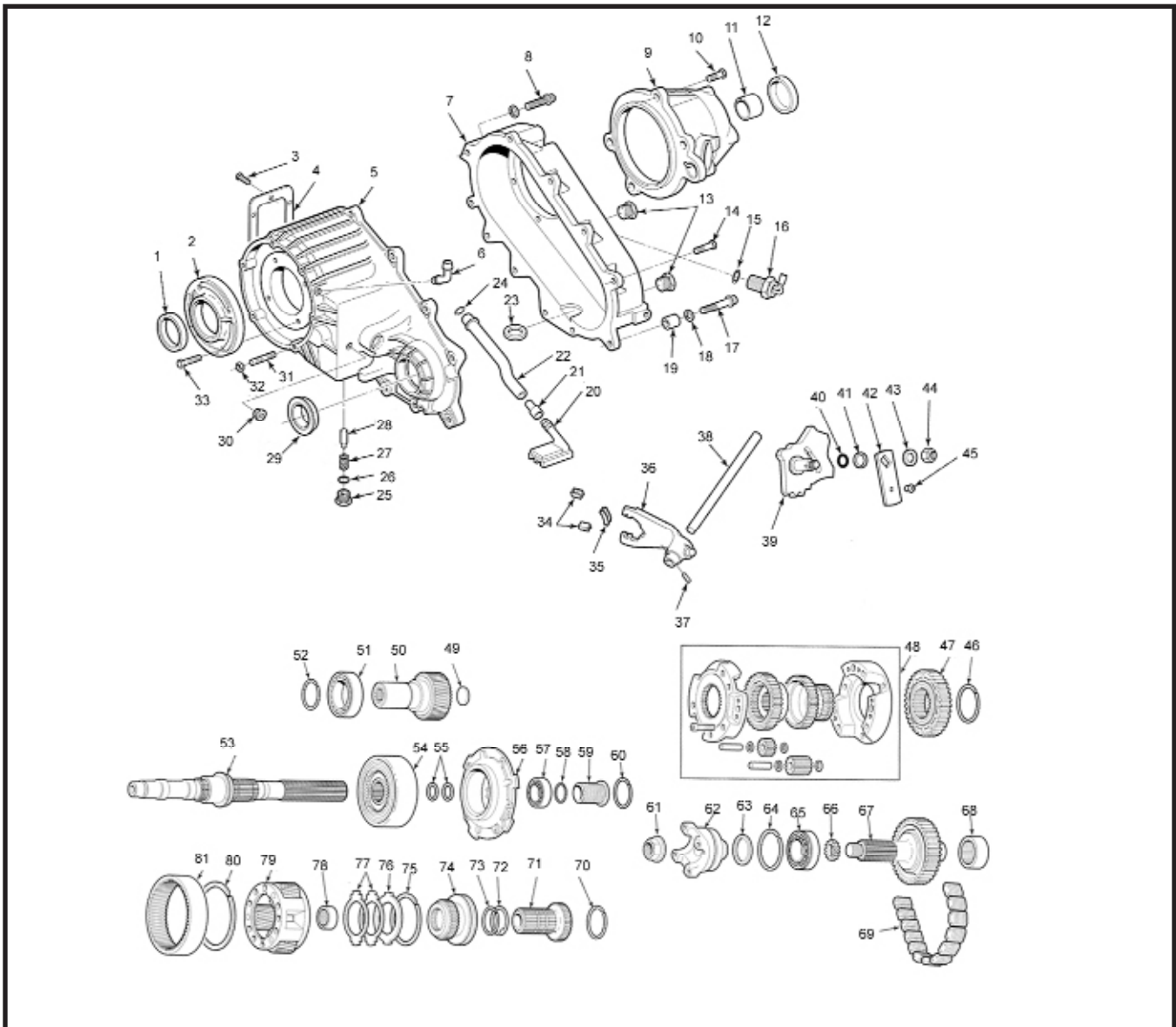

ILL #	MIDWEST #	REF #	REPLACEMENT PART DESCRIPTION
1	3173	4167929	SEAL, INPUT
2	NV16187	4338972	INPUT RETAINER - 249, 1993-98
2	4864782		INPUT RETAINER - 247, 1999-ON
3			SCREW, PTO COVER
4			COVER, PTO
5	NV17238	4638881	CASE - FRONT HALF 1993
5	4796974		CASE - FRONT HALF 1994-95
5	NV19057	4798124	CASE - FRONT HALF 1996-98
5	NV27297	5012309AA	CASE - FRONT HALF 1999-2002
6	NV16090	4338957	VENT
7	NV16667	4638892	CASE - REAR HALF 1993-96, 1997-98 - V6
7	NV26342	4886206AA	CASE - REAR HALF 1997-98 - V8
7	NV26973	5012323AA	CASE - REAR HALF 1999-2002
8	NV61573	4210617	SCREW & CASE ASSY
9	NV17554	4728161	REAR EXTENSION 1993-98
9	NV25810	5012332AA	REAR EXTENSION 1999-2002 - ALL, 01 - 2001 - V8, 2002
9	NV42202	5066086AA	REAR EXTENSION 2001-2002 - V6
10	6501371		SCREW, REAR RETAINER
11	WT266-62	16696	BUSHING, REAR RETAINER
12	4370N		SEAL, REAR OUTPUT (EARLY)

NV247/249J STYLE (cont.)

ILL #	MIDWEST #	REF #	REPLACEMENT PART DESCRIPTION
13	NV15054	4210606	PLUG, DRAIN/FILL
14	NV61573	4210617	SCREW, CASE FLANGE
15	4338956		O-RING
16	56006755		SWITCH
17	NV61575	4210614	SCREW & CASE ASSY DOWEL
18	NV15142	4210983	WASHER, DOWEL
19	NV13627	41166310	DOWEL, CASE ALIGNMENT
20	5012326AA		SCREEN, OIL PUMP 1999-2002
20	NV16217	4338943	SCREEN, OIL PUMP
21	NV16218	4338944	CONNECTOR, OIL TUBE
22	NV16669	4638893	OIL TUBE
23	NV95422	3681601	MAGNET
24	NV16214	4338942	O-RING, OIL TUBE
25	NV16756	53008216	SCREW, POPPET
26	NV15715	4338956	SEAL, O-RING
27	NV17071	4638497	SPRING, PLUNGER
28	NV16754	53008217	PLUNGER, POPPET
29	3946	4762899	SEAL, FRONT OUTPUT EARLY - LATE STYLE 4798125 - 1996-ON
31	4167922		STUD, CASE MOUNTING
33	6500318		SCREW, INPUT RETAINER
34	4167969		FORK PADS, TIPS (2 REQ.) - CAN USE 15866
35	4167970		FORK PAD, CENTER - CAN USE 15866
36	5003459AA		RANGE FORK 1993-95 - 249 IRON STYLE w/ CASTING C16448
36	4798136		RANGE FORK 1996-ON-247 UNIT, 1996-99 249 UNIT ALUMINUM STYLE w/ CASTING C17833
37	8133636	91386	PIN, FORK TO RAIL
38	NV16449	83504469	RAIL, FORK SHIFT
39	NV17243	4638889	SECTOR ASSY
40	NV13725	4167963	O-RING, SECTOR SHAFT
41	NV13726	4167964	RETAINER, O-RING
42	NV17253	4638906	LEVER & GROMMET
43	2436163		WASHER, LEVER
44	NV13992	152345	NUT, OPERATING LEVER
45	NV16566	53004810	GROMMET
46	NV13877	83503532	SNAP RING, SPROCKET RETAINING
47	NV17548	4728157	SPROCKET, DRIVE - 1-1/4" CHAIN, 1993-98 (249 UNIT)
47	NV25446	5012319AA	SPROCKET, DRIVE - 1" CHAIN, 1999-2002 (247 UNIT)
48	NV17509	4723917	DIFFERENTIAL ASSY 1993-98
48	5012315AA		DIFFERENTIAL ASSY 1999-ON
49			PLUG, INPUT
50	NV17108	4636792	SHAFT - INPUT, 1993 - 1ST DESIGN (BD50-8 BEARING)
50	4796972		SHAFT - INPUT, 1994-95 - V6
50	4796976		SHAFT - INPUT, 1994-95 - V8
50	4798126		SHAFT - INPUT, 1996-ON, ALL (EXC. BELOW)
50	5012311AA		SHAFT - INPUT, 1999-ON - V8
50	NV17949		SHAFT - INPUT, W/6010, BRG. 5 1/8", 23 SPLINE
50	NV17822		SHAFT - INPUT, SAME AS 17949 BUT W/BD50-8 BEARING
51	BD50-8		BEARING, INPUT TO 1994 - (WIDE)
51	110L		BEARING, INPUT 1995-ON (THIN)
52	853851	89331A	SNAP RING
53	4728155		MAIN SHAFT, 1993-95
53	4798127		MAIN SHAFT, 1996-98
53	5012313AA		MAIN SHAFT, 1999-ON
54	4723918	4897221AA	VISCOUS COUPLING 1993-96 (249 T/C)
54	4897220AA		VISCOUS COUPLING 1997-98 - CAN USE 4723918 (249 T/C)
54	5012329AA		VISCOUS COUPLING 1999-ON (247 T/C)
55	4638895		SNAP RING
56	NV16686	4638896	OIL PUMP, 249 UNIT
56	NV33261	5013017AB	OIL PUMP, 247 UNIT
57	206L	4638899	BEARING, REAR OUTPUT
58	4467478		SNAP RING, M/S BEARING
59	4638900		SPEEDO GEAR TO 1998
60	4638905		SNAP RING
61	NV13368	4167924	NUT, YOKE - 1993-96
61	152345		NUT, YOKE - 1997-98
61	4167924		NUT, YOKE - 1999-2002
N.I.	NV13695	4210973	WASHER, YOKE
62	4856142		YOKE, FRONT OUTPUT 1993-95

NV247/249J STYLE (cont.)

ILL #	MIDWEST #	REF #	REPLACEMENT PART DESCRIPTION
62	4798138		YOKE, FRONT OUTPUT 1996-98
62	5012308AA		YOKE, FRONT OUTPUT 1999-2000, 2001 - V6
62	5019514AA		YOKE, FRONT OUTPUT 2001 - V8
63			WASHER
64	853851		SNAP RING
65	207XLO	2466224	BEARING, FRONT OUTPUT
66	611689		SEAL, YOKE SPLINE
67	NV17555	4728158	SHAFT, FRONT OUTPUT - 1-1/4" CHAIN, 1993-98 (249 UNIT)
67	NV25832	5012321AA	SHAFT, FRONT OUTPUT - 1" CHAIN, 1999-2002 (247 UNIT)
68	SCE2416	4269189	NEEDLE BEARING, FRONT OUTPUT
68	4638899		NEEDLE BEARING, FRONT OUTPUT 1999-2002
69	HV034	4728159	CHAIN - 249, 1-1/4" WIDE
69	HV071	5012322AB	CHAIN - 247, 1" WIDE
70	NV16297	83503537	SNAP RING, DIFF. GEAR
71	NV16659	4638888	SHAFT, INTERMEDIATE
72	NV16467	83503539	WASHER, CLUTCH SHAFT
73	NV16466	83503540	SNAP RING, INTERMEDIATE SHAFT
74	53006090		SLIDING CLUTCH, 1993-95
74	4798132		SLIDING CLUTCH, 1996-98
74	5012314AA		SLIDING CLUTCH, 1999-ON
75	NV16243	4338910	SNAP RING, CARRIER LOCK
76	NV16397	4338909	RING, CARRIER LOCK
77	NV17612	4338908	WASHER, INPUT THRUST
78	FC66561		NEEDLE BEARING, INPUT POCKET
79	NV16551	53006087	PLANETARY ASSY, 1993
79	4796903		PLANETARY ASSY, 1994-2001
79	4796903AB		PLANETARY ASSY, 2002-ON
80	NV13863	4219065	RETAINING RING, ANNULUS
81	83503122		ANNULUS GEAR

KITS

T249R	➔ BEARING, SEAL & GASKET KIT
T249RHD	➔ BEARING, SEAL & GASKET KIT - HEAVY DUTY
T249RL	➔ BEARING, SEAL & GASKET KIT - LATE
T484R	➔ BEARING, SEAL & GASKET KIT (247 UNIT)
K249	➔ GASKET & SEAL KIT
K247J	➔ GASKET & SEAL KIT
SPTC249-50	➔ SMALL PARTS KIT

BW1370 STYLE

CHEVROLET® P/U 1989-91

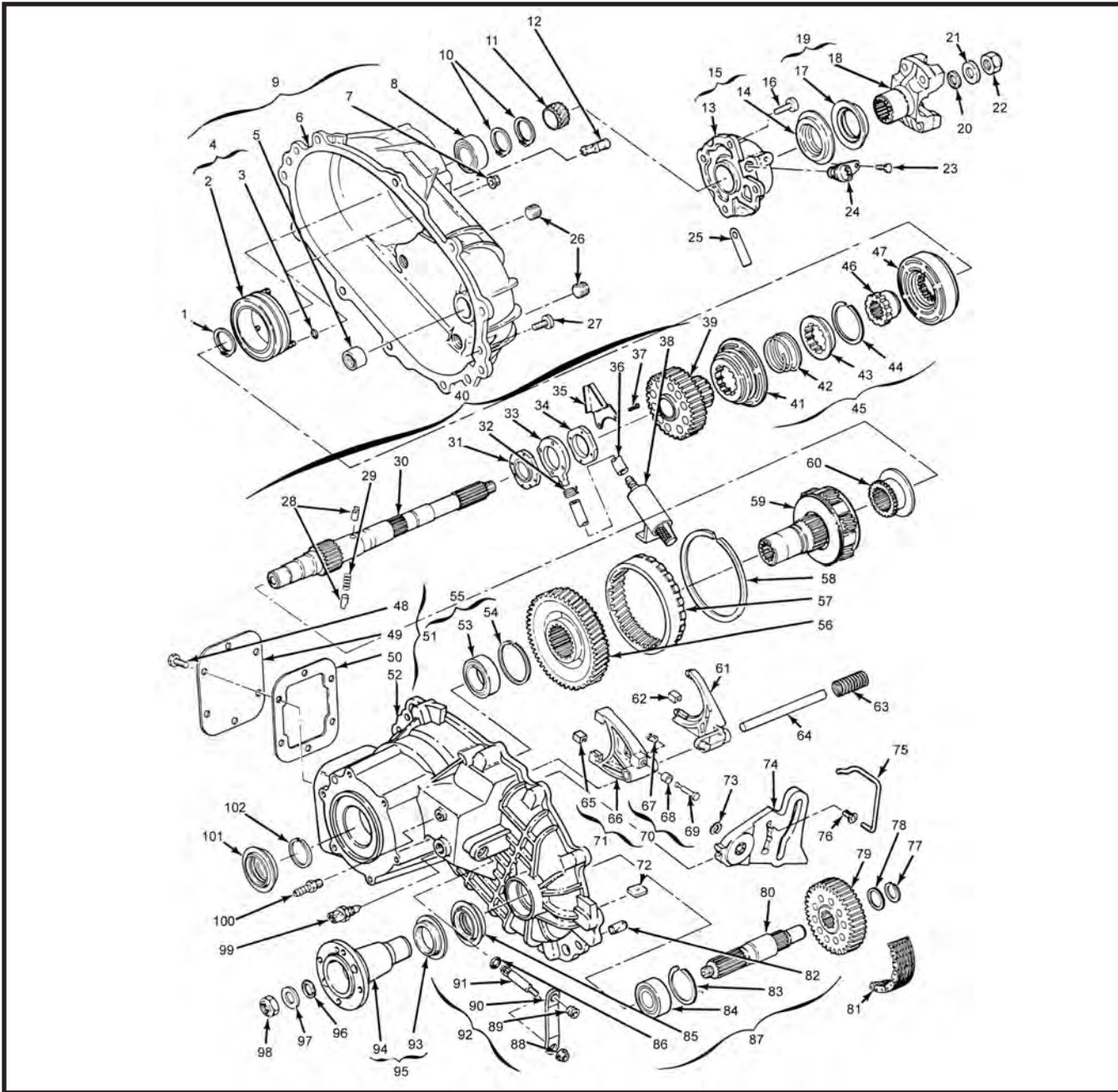

ILL #	MIDWEST #	REF #	REPLACEMENT PART DESCRIPTION
1	1300139027		SNAP RING
2	1370140004		COIL, CLUTCH SHIFT
3	1000141007		O-RING
4	1370640004		COIL ASSY, CLUTCH SHIFT
5	SCE2012		NEEDLE BEARING, FRONT OUTPUT PILOT
6	1370039002		CASE HALF, REAR
7	1300149002		NUT
8	207		BEARING, FRONT OUTPUT
9	4401539001		CASE HALF ASSY, REAR
10	1300139027		SNAP RING (2 REQ.)
11	1370110001		GEAR - SPEEDO
12	1370140003		TERMINAL
13	1370066004		REAR EXTENSION HOUSING (SLIP YOKE)
14	1900044012		SEAL, REAR OUTPUT (BOLT ON YOKE)

BW1370 STYLE (cont.)

ILL #	MIDWEST #	REF #	REPLACEMENT PART DESCRIPTION
14	1900044013		SEAL, REAR OUTPUT (SLIP YOKE)
16	1300183017		BOLT
17	1300035001		SHIELD
18	1370031001		YOKE
18	1370031002		YOKE
19	1370531002		YOKE ASSY, REAR (BOLT ON)
19	1370531001		YOKE ASSY - SHIELD
20	1000044045		OIL SEAL - SPLINE
21	1000047015		WASHER
22	1000149002		NUT
22	1900149002		NUT, REAR YOKE
23	11503080		BOLT
24	1370640001		SENSOR, SPEEDO
25	1370199001		I.D. TAG (VARIES)
26	1300052003		PLUG, DRAIN/FILL (2 REQ.)
27	1300183017		BOLT
28	1345043007		PUMP PIN
29	1345156004		SPRING, PUMP
30	SEE ITEM #40		
31	1345039007		PUMP COVER, FRONT
32	1345056005		CLAMP
33	1345097004		HOUSING, MAIN PUMP BODY
34	1345039005		PUMP COVER, REAR
35	1356056004		RETAINER, PUMP
36	1356034001		HOSE
37	1345183003		BOLT, PUMP
38	1345238001		FILTER
39	1356144003		CHAIN SPROCKET, DRIVE
40	4401410003		MAIN SHAFT ASSY, BOLT ON YOKE (INCLUDES PUMP & RANGE HUB)
40	4401410002		MAIN SHAFT ASSY, SLIP YOKE (INCL. PUMP & RANGE HUB)
41	4400055001		LOCKUP COLLAR
42	1350156007		SPRING, RETURN
43	1900089001		HUB - MODE SHIFT
44	1000139041		SNAP RING
45	1356589002		MODE SHIFT ASSY
46	1356090002		SHIFT HUB, MODE
47	4470410001		HOUSING CLUTCH
48	1000183041		BOLT
49	1300191010		COVER, PTO
50	PTO-55		GASKET, PTO
51	4401565001		CASE HALF, FRONT (ASSY ONLY)
52	4401565001		CASE HALF, FRONT
53	6010N	1300130001	BEARING, INPUT
54	1300139010		SNAP RING
56	1356070001		PTO DRIVE GEAR
57	1356162002		RING GEAR, PLANETARY
58	1300139012		SNAP RING
59	1370659004		INPUT - PLANETARY ASSY
60	1356089001		RANGE HUB
61	1356096007		FORK, MODE SHIFT
62	1345235001		FORK PADS
63	4400156001		SPRING
64	1350100001		SHIFT RAIL
65	1356235001		FORK PADS
66	4400596001		FORK, RANGE SHIFT
67	1350040002		RETAINER
68	1352127001		CAM ROLLER
69	1350043001		PIN
70	1350543001		PIN, ROLLER AND RETAINER ASSY
71	4400596001		FORK - ASSY ONLY
72	1000012002		MAGNET
73	1345056002		CLIP RING
74	1370099002		SHIFT CAM
76	1300127001		BUSHING - CAM SPRING
77	1345139004		RETAINING RING
78	1345193005		WASHER
79	1356144002		CHAIN SPROCKET, DRIVEN
80	1370171003		OUTPUT SHAFT - FRONT
81	HV025		CHAIN

BW1370 STYLE (cont.)

ILL #	MIDWEST #	REF #	REPLACEMENT PART DESCRIPTION
82	1300043009		DOWEL PIN w/o PTO (2 REQ.)
82	1300043005		DOWEL PIN w/ PTO (2 REQ.)
83	T86-7.5		SNAP RING
84	207		BEARING, FRONT OUTPUT
85	1900044012		SEAL, FRONT OUTPUT
86	1300016001		SEAL - SHIFT SHAFT
88	1300149005		NUT
N.I.			BUSHING, SLIP YOKE
89	1300102001		GROMMET
90	1370098002		LEVER
91	1370122002		SHIFT SHAFT
92	1370598002		SHIFT LEVER ASSY
99	1370140002		SWITCH - 4WD INDICATOR
100	1345072001		BREATHER BARB
101	1900044012		SEAL - INPUT
102	1300139009		SNAP RING

KITS

T1370R	→ BEARING KIT
SP1370-50	→ SMALL PARTS KIT
K1370	→ GASKET & SEAL KIT
PK1356	→ PUMP KIT

Axle Shafts



MIDWESTTM
TRUCK & AUTO PARTS INC.

MotiveGear Performance WORLD AMERICAN MotiveGear

Axle Shafts

Heavy Duty, Light Duty & Performance

- OE Quality Replacement Parts
- Backed by Warranty
- Three Distribution Locations Means Quick Delivery



Heavy Duty, Light Duty & Performance Axle Shafts

O.E. quality axle shafts for popular applications in today's aftermarket. This catalog includes comprehensive coverage of high demand domestic and import applications.

BW4470 STYLE

GM® K3500 - 1989-97

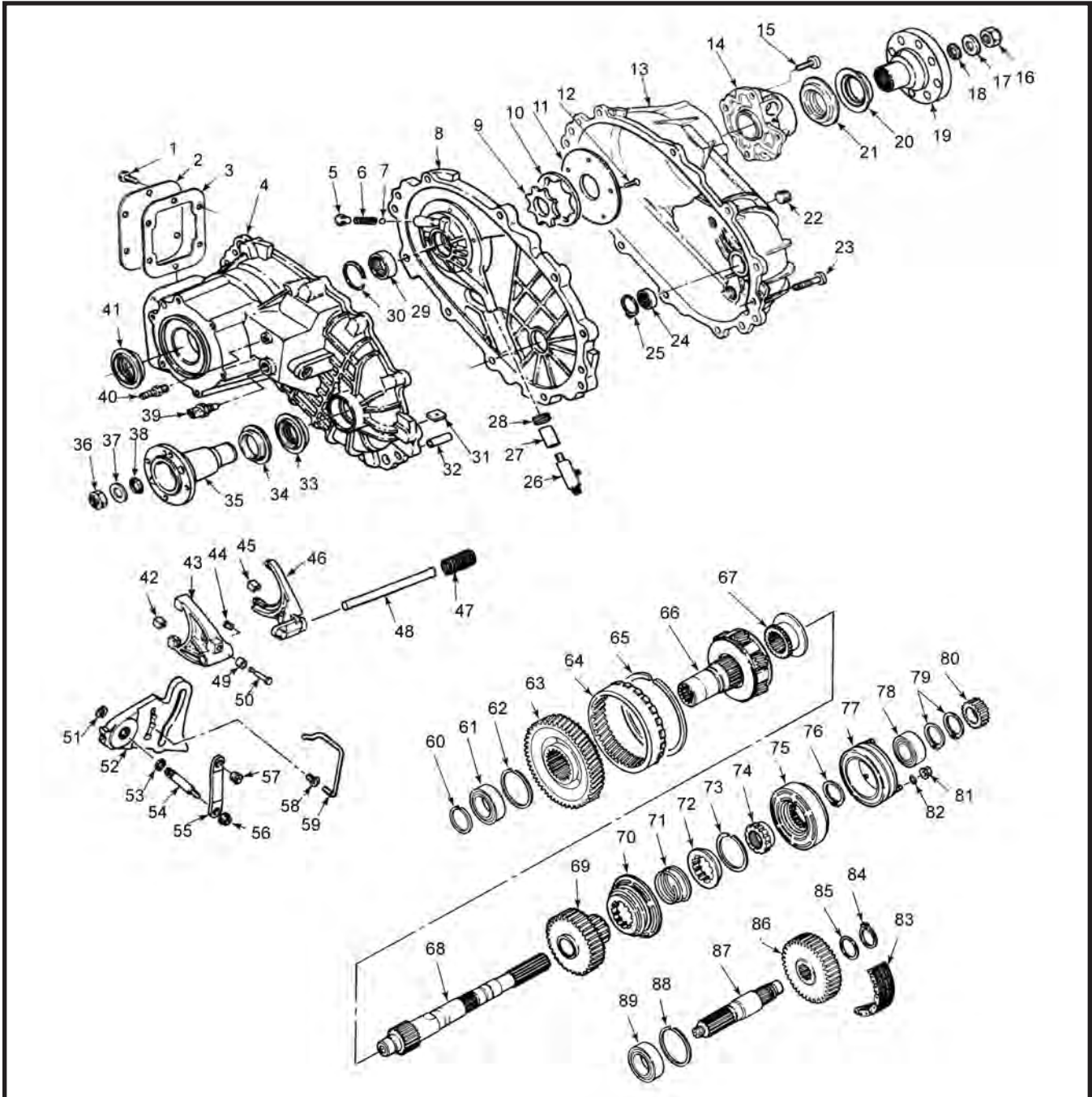

ILL #	MIDWEST #	REF #	REPLACEMENT PART DESCRIPTION
1	1000183041		BOLT - PTO COVER
2	1300191010		COVER - PTO
3	1300045001		GASKET - PTO
4	1370565004		FRONT CASE ASSY
4	1370565006		FRONT CASE ASSY
4	1370065004		FRONT CASE HALF
5	1900052002		PLUG
6	1900156002		SPRING
7	1900109001		CHECK BALL
8	1370607002		SPACER & PUMP ASSY
8	1370107002		SPACER, FRONT AND REAR CASE HALF
9	1370601101		GEAR ASSY, PUMP (INCLUDES INNER AND OUTER)

BW4470 STYLE (cont.)

ILL #	MIDWEST #	REF #	REPLACEMENT PART DESCRIPTION
9	1370101001		GEAR, PUMP - INNER
10	1370101002		GEAR, PUMP - OUTER
11	1370039006		PUMP COVER
12	1900183001		SCREW
13	1370539005		REAR CASE ASSY
13	1370039005		REAR CASE HALF
14	4470527001		BEARING CAP ASSY
15	1300183017		BOLT
16	1900149002		NUT
17	1000047015		WASHER
18	1000044045		SEAL - SPLINE
19	4470566001		EXTENSION ASSY
19	1370566007		EXTENSION AND BUSHING ASSY
20	1300035001		SLINGER
21	1900044012		SEAL, REAR OUTPUT
22	445751		PIPE PLUG 1/2"
23	1300183016		BOLT
24	1000132044		BEARING, NEEDLE
25	1900139011		RETAINING RING
26	1370238001		OIL STRAINER
27	1900034003		HOSE, PUMP
28	1300056066		CLAMP, HOSE
29	1300132015		NEEDLE BEARING, FRONT OUTPUT PILOT
30	1900139010		RETAINING RING
31	1000012002		MAGNET
32	1300043007		DOWEL PIN
33	1900044012		SEAL - FRONT OUTPUT
34	1300035001		SLINGER - FRONT OUTPUT YOKE
35	1370031001		FLANGE - FRONT OUTPUT
36	1000149002		NUT
37	1000047015		WASHER
38	1000044045		SEAL - FLANGE SPLINE
39	1370140002		SWITCH - 4WD INDICATOR
40	1345072001		BARB - BREATHER
41	1900044012		SEAL - INPUT
42	1356235001		FORK INSERTS (RANGE)
43	4400596001R		SHIFT FORK - RANGE
44	1350040002		RETAINER - ROLLER PIN
45	1345235001		FORK INSERTS (MODE)
46	4470596001		SHIFT FORK - MODE
49	1352127001		ROLLER
50	1350043001		PIN, FORK ROLLER
51	1345056002		RING, CLIP
52	1370099002		CAM, SHIFT
53	1300016001		SEAL, SHIFT SHAFT
54	1370598002		SHIFT LEVER ASSY
54	1370122002		SHAFT, SHIFT
55	1370098002		LEVER (ASSY)
56	1300149005		NUT
57	1300102001		GROMMET
58	1300127011		BUSHING, ASSIST SPRING
59	1370156001		SPRING, ASSIST
60	1300139009		RETAINING RING
61	1300130001		BEARING, INPUT
62	1300139010		SNAP RING
63	4400020001		GEAR, PTO DRIVE
64	1356162002		RING GEAR
65	1300139012		SNAP RING
66	1370659004		INPUT AND PLANETARY ASSY
67	1356089001		SHIFT HUB, RANGE
68	1370171004		MAIN SHAFT - FIXED YOKE
69	1370144001		SPROCKET - DRIVE
70	4400055001		COLLAR, MODE
71	1350156007		SPRING
72	1900089001		HUB, MODE
73	1000139041		SNAP RING
74	1370090001		HUB, SHIFT COLLAR
75	4470410001		KIT, MAGNETIC LOCKUP
75	1370212001		HOUSING, CLUTCH

BW4470 STYLE (cont.)

ILL #	MIDWEST #	REF #	REPLACEMENT PART DESCRIPTION
76	1300139030		SNAP RING
77	1370640004		COIL ASSY, CLUTCH
78	208		BEARING, REAR OUTPUT
79	1300139030		RETAINING RING
80	1370110002		ROTOR - SPEEDO
81	1300149002		NUT
82	1000141007		O-RING
83	HV031		CHAIN
84	1300139030		RETAINING RING
85	1300193004		WASHER
86	1370144002		SPROCKET - DRIVEN
87	4470171001		SHAFT - FRONT OUTPUT
88	T86-7.5		SNAP RING
N.I.	11503080		BOLT
89	207		BEARING - FRONT OUTPUT
N.I.	1370640001		SENSOR, SPEED

KITS

T4470R	→	BEARING KIT
SP4470-50	→	SMALL PARTS KIT
K4470	→	GASKET & SEAL KIT
4470410002	→	M/S KIT FOR FIXED YOKE - INCLUDES SHAFT AND RANGE HUB

Rebuilt Transmissions & Transfer Cases

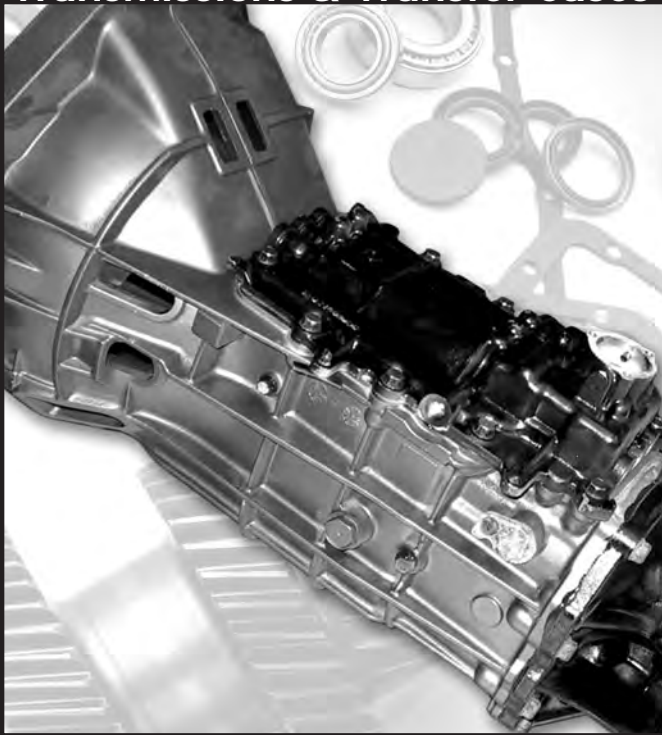

- ▶ Rebuild kits and parts are available.
- ▶ Transmissions & transfer cases are rebuilt using the highest standards.

BW4472 STYLE

GM® BRAVADA, SAFARI, CYCLONE, TYPHOON, AND JIMMY 1990-97

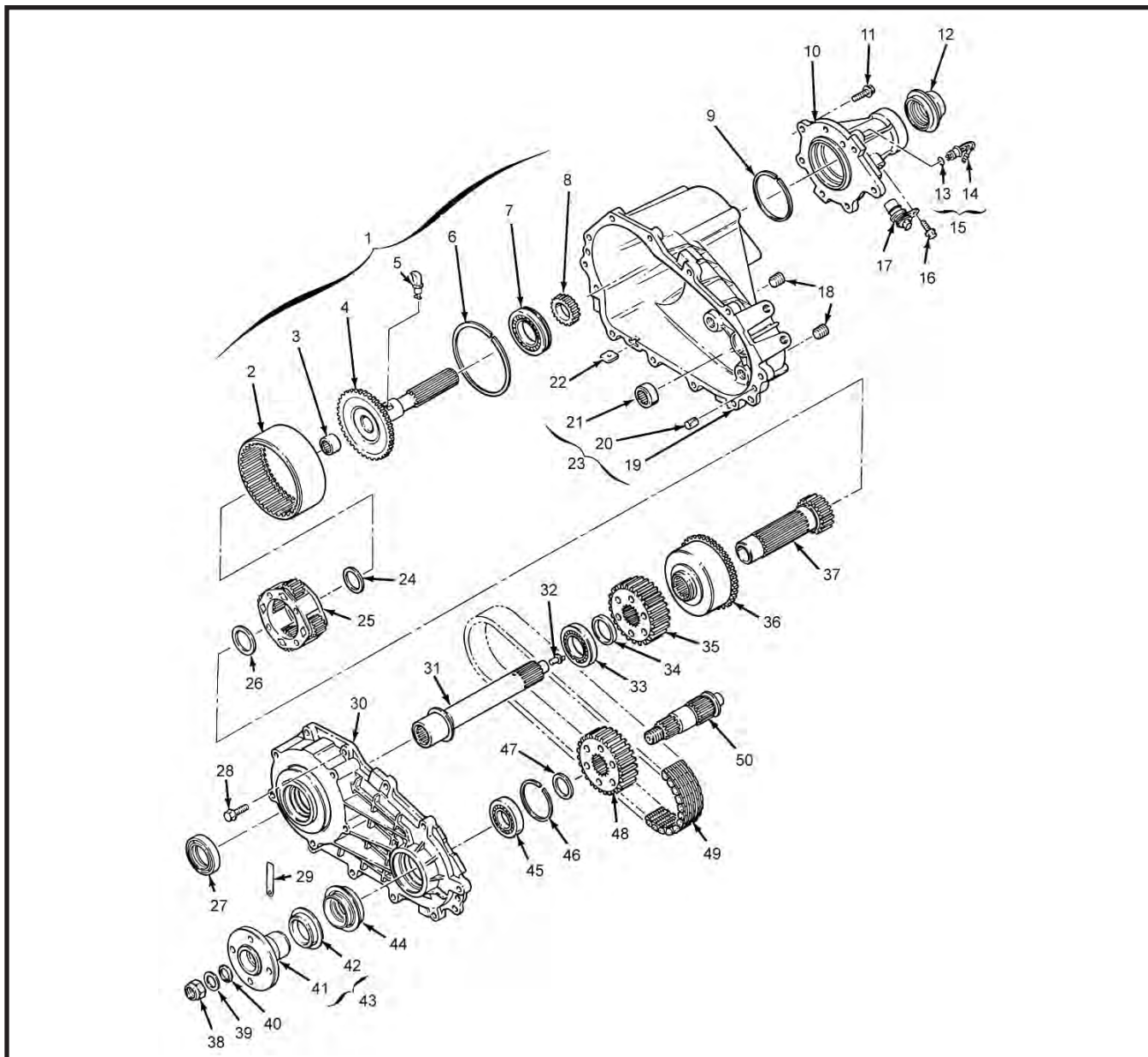

ILL #	MIDWEST #	REF #	REPLACEMENT PART DESCRIPTION
2	1372162001		RING GEAR
3	SCH1310		NEEDLE BEARING, INPUT PILOT
4	1372171003.		OUTPUT SHAFT, REAR - ASSY #'S 4472 - 001, 004, 007, 009
4	4472171002		OUTPUT SHAFT, REAR - ASSY #'S 4472 - 005, 006, 008, 012, 013
4	4472031001		FLANGE - ASSY #4472 - 001, 004, 005, 006, 009
5	1300035001		SLINGER
5	1900034001		OIL SCOOP
6	1900139001		SNAP RING
7	208SL		BEARING, REAR OUTPUT
8	1370110002		ROTOR, SPEEDO
9	1900139003		SNAP RING
10	4472566002		EXTENSION HOUSING - ASSY #'S 4472 - 001, 007, 009
10	4472566001		EXTENSION HOUSING - ASSY #'S 4472 - 005, 006, 008, 012, 013

BW4472 STYLE (cont.)

ILL #	MIDWEST #	REF #	REPLACEMENT PART DESCRIPTION
11	1900183010		BOLT, EXTENSION HOUSING (7 REQ.)
12	1900044012		SEAL - OUTPUT - BOOT (1900044012)
12	1900072001		BREATHER 1990-96
12	1900044012		SEAL - OUTPUT - NO BOOT
13	1000141014		O-RING
15	1900572001		BREATHER ASSY
16	11503080		BOLT
17	1370640001		SENSOR, SPEEDO
18	445751		PLUG, DRAIN/FILL
19	1372565001		CASE ASSY, REAR HALF
19	N.S.S.		CASE HALF, REAR - USE ASSY #47
20	1300043005		DOWEL PIN
21	JH1612		NEEDLE BEARING, FRONT OUTPUT
23	1000012002		MAGNET
24	1900193006		THRUST WASHER
25	4472659003		PLANETARY ASSY
26	109		BEARING, INPUT
26	1900193005		THRUST WASHER
27	710062		SEAL, INPUT
28	1900183010		BOLT, CASE (11 REQ.)
30	4472539001		FRONT CASE HALF
30	4472539003		FRONT CASE HALF
31	4472189001		INPUT SHAFT
32	1352034002		FUNNEL, OIL
34	1900053001		SPACER, SPROCKET
35	1372144001		SPROCKET, DRIVE
36	1372625001		VISCOUS CLUTCH
37	4472665001		SUN GEAR - BUSHING
37	1372671003		MAIN SHAFT ASSY - ASSY #'S 4472 - 001,004, 007, 009, 011(VANS)
37	4472671002		MAIN SHAFT ASSY - ASSY #'S 4472 - 000, 005, 006, 008, 012, 013
37A	4472165001		SUN GEAR SEPARATE
38	1900149001		NUT, OUTPUT
39	1000047016		WASHER, OUTPUT YOKE
41	4472531001		FLANGE ASSY, FRONT OUTPUT - SEAL
41	4472531002		FLANGE ASSY, FRONT OUTPUT - ASSY# 4472, 007, 008, 012, 013
41	4472031003		FLANGE - ASSY# 4472, 007, 008, 012, 013
44	1900044012		SEAL, FRONT OUTPUT
45	207		BEARING, FRONT OUTPUT
46	1900139007		RETAINING RING
47	1372053002		SPACER, BEARING
48	1372144002		SPROCKET, DRIVEN
49	HV033	1372143001	CHAIN - #4472, 001, 004, 005, 006, 008, 012, 013 - 1 BLUE LINK
49	HV032		CHAIN - #4472, 007, 009 - 2 BLUE LINKS
50	4472171001		SHAFT, FRONT OUTPUT

KITS

T4472R	→ BEARING, GASKET & SEAL KIT
K1372	→ GASKET & SEAL KIT

NP203 STYLE

CHEVROLET®, DODGE®, FORD®

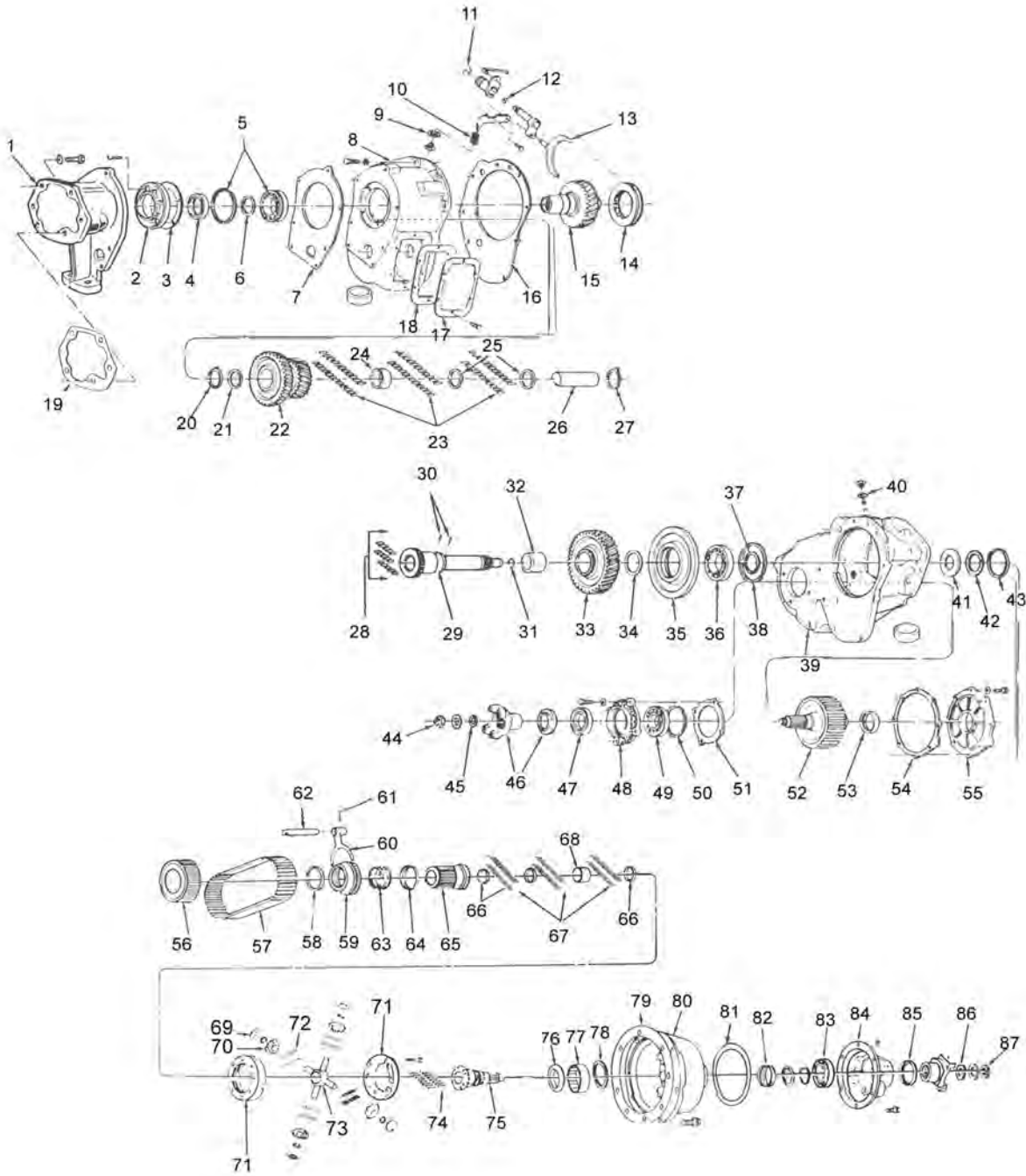

ILL #	MIDWEST #	REF #	REPLACEMENT PART DESCRIPTION
1			ADAPTER - CALL - APPLICATION
2	6273987		RETAINER - FRONT BEARING, CHEVY
2	11460	D3TZ7050E	RETAINER - FRONT BEARING, FORD*
3	3820897	D3TZ7181E / 335200	GASKET - FRONT RETAINER
4	4269183	9057006	SEAL - INPUT (2 REQ.)
5/36	1210L	3820892	BEARING, INPUT
6/37	3821557		SNAP RING, INPUT BEARING
7	3821477	2466954	GASKET, ADAPTER
8			HOUSING - CALL - APPLICATION
9	3515027		GASKET, POPPET SPRING

NP203 STYLE (cont.)

ILL #	MIDWEST #	REF #	REPLACEMENT PART DESCRIPTION
10	4116315	335172	SPRING, POPPET PLATE
11	3820884		O-RING, RANGE BOX
12	1536267	3845164	O-RING, SHIFT RAIL
13	3410038	D4TZ7289A	FORK, SHIFT
14	3821362	D4TZ7100B / 336193	SLEEVE, RANGE SHIFT
15	11401	6273962	INPUT SHAFT, 27 SPL. MALE, CHEVY/GMC TURBO 350
15	11624	6259040	INPUT SHAFT, 27 SPL. FEMALE, CHEVY/GMC TURBO 350
15	13343	676270	INPUT SHAFT, 32 SPL. FEMALE, CHEVY/GMC TURBO 400, MANUAL
15	11857	344276	INPUT SHAFT, 10 SPL., CHEVY/GMC MANUAL
15	3820891		INPUT SHAFT, DODGE
15	11895	D4TZ7158A	INPUT SHAFT, 32 SPL., FORD 6-13/16" O.A.
15	11874	D4TZ7017A	INPUT SHAFT, 31-29-28, FORD 4-25/32" O.A.
16	11870	3820890	GASKET, CASE
17	NV35662		COVER, PTO
18	PTO-55	B9TZ7166C	GASKET, PTO
19	N/A		GASKET - VARIES
20/27	3821412	335179	THRUST WASHER, COUNTER GEAR
21	3821411	D4TZ7115D / 335177	SPACER, COUNTER GEAR BEARING (SHORT)
22	3821409	D4TZ7D144A / 335180	GEAR, RANGE COUNTER
24	3821410	D4TZ7115A / 335178	SPACER, COUNTER GEAR BEARING (LONG)
25	3821411	D4TZ7115D / 335177	SPACER, COUNTER GEAR BEARING (SHORT)
26	3821407	D4TZ7111A / 335176	SHAFT, RANGE COUNTER GEAR
29	3821352	D4TZ7017B / 6273982	MAIN SHAFT
30	2952592	D3TZ7C018A / 9431704	PIN, THRUST WASHER
31	3821353	87036-594 / 6264903	O-RING, MAIN SHAFT
32	3821356		SPACER
33	3821354	D4TZ7100D / 6259073	GEAR - LOW SPEED - 42T
34	3821357	D4TZ7C350A / 335191	THRUST WASHER, LOW GEAR
35	3821359		RETAINER 7-5/32" O.D. X 1-5/8"
38	1618A	D4TZ7N281A	SNAP RING, .104 PILOT BEARING
38	1618B	D4TZ7N281B	SNAP RING, .109 PILOT BEARING
38	1618C	D4TZ7N281C	SNAP RING, .114 PILOT BEARING
39	CALL		HOUSING, CHAIN DRIVE - CALL - APPLICATION
40	1092545	D3TZ7181F / 3967885	GASKET, POPPET SPRING
41	3821369	D4TZ7A385A / 335185	THRUST WASHER
42	3821370	D4TZ7C341A / 6259039	THRUST WASHER
44	3821563		NUT, FRONT YOKE
N.I.	2070117		WASHER, FRONT YOKE
45	3822840	D4TZ7A385B / 347433	SEALING WASHER, SPLINE
46	3898688		YOKE, FRONT OUTPUT - DODGE
47	710005	D4TZ7B215D / 4086649	SEAL, FRONT OUTPUT
48	4167727		RETAINER, FRONT OUTPUT BEARING w/o SEAL
50	2124518	C5TZ7070A	SNAP RING, BEARING (INCLUDE - 45
51	4210975	D4TZ7086D / 6259037	GASKET, FRONT OUTPUT RETAINER
52	3894489	D4TZ7061A	SHAFT, FRONT OUTPUT - (SHAFT ONLY)
52	3898368		SPROCKET, 2-1/2" CHAIN
52	13432		SPROCKET, 2" CHAIN
53	BCE2816	TYAA-7127A / 1265674	BEARING, FRONT OUTPUT PILOT
54	4210976	D4TZ7181G / 6259083	GASKET, FRONT OUTPUT RETAINER, REAR
55	2954130	D3TZ7085D / 3967899	RETAINER, FRONT OUTPUT, REAR
56	3898368	D6TZ7177A / 465410	SPROCKET, 2-1/2" CHAIN (FORD ALSO)
56	13432	D4TZ7177A / 474614	SPROCKET, 2" CHAIN
57	11428	HV005	DRIVE CHAIN, 1ST DESIGN, 2-1/2" WIDE
57	13433	HV009	DRIVE CHAIN, 2ND DESIGN, 2" WIDE
57	13624		KIT - DRIVE CHAIN 1 - 2" CHAIN, 2 SPROCKETS
59/43	3821372	D4TZ7917A / 335069	SNAP RING, DRIVE SPROCKET
59	3821374	D4TZ7100A / 347440	SLIDING CLUTCH
60	3820879	D4TZ7289B / 6259150	FORK - LOCKOUT
61	4036691	3727187	PIN - SHIFT HEAD
62	3820877	D4TZ7240A / 335187	RAIL - SHIFT
63	3821375	D4TZ7D126A / 335184	SPRING - LOCKOUT CLUTCH
64	3821376	D4TZ7067A / 335188	SEAT, SPRING
65	3821365	D4TZ7060A / 6273994	SHAFT, DIFF. OUTPUT - 61 EXT. TEETH (16T) 5-19/32" O.A.
66	3821366	D4TZ7115B / 347442	SPACER, DIFF. OUTPUT SHAFT (3 REQ.)
67	QAR29523		NEEDLE BEARING - FRONT OUTPUT/DIFF. (132 REQ.)
68	3821367	D4TZ7115E / 335194	SPACER
69	3821382	D4TZ7728A / 6293996	THRUST WASHER, DIFF. PINION (4 REQ.)
70	3821385	D4TZ7C416A / 6273995	PINION GEAR (4 REQ.)
71	4115251	D8TZ7A219A	DIFF. CASE - TWO HALVES - BOLTS ONLY

NP203 STYLE (cont.)

ILL #	MIDWEST #	REF #	REPLACEMENT PART DESCRIPTION
72	Q8113	3821384	NEEDLE BEARING - PINION GEARS (132 REQ.)
73	4115252	D8TZ7A399A / 476778	SPIDER - DIFF.
74/28/23	QAR29523	D3Z7102A / 9431705	NEEDLE BEARING, COUNTER GEAR (102 REQ.)
75	4036435	D6TZ7061A / 458500	OUTPUT SHAFT - 30 SPL.
76	3894957	D8TZ7C010A	OIL PUMP
77	B3616		BEARING, DIFF. HOUSING
78	3821390	D4TZ7A248A	SEAL, DIFF. HOUSING
79	3894484	/ 344263	GASKET, REAR OUTPUT RETAINER
80	6259079		HOUSING, REAR OUTPUT FRONT HALF - 1ST DESIGN, CHEVY
80	468209		HOUSING, REAR OUTPUT FRONT HALF - 2ND DESIGN 1975-79 CHEVY
80	4115333		HOUSING, REAR OUTPUT FRONT HALF - DODGE*
81	3894487	D4TZ7A548A / 13051	O-RING, REAR RETAINER
82	3732038	3727142	SPEEDO GEAR, 5T - CHEVY, DODGE, FORD*
82	6273992		SPEEDO GEAR (RED), 7T - CHEVY
83/49	307L	908182	BEARING, FRONT OUTPUT (2 REQ.)
84	346396		HOUSING, REAR OUTPUT REAR HALF - 1973-78 CHEVY
84	468204		HOUSING, REAR OUTPUT REAR HALF - 1979 CHEVY
84	3821394		HOUSING, REAR OUTPUT REAR HALF - DODGE
84	11922	D4TZ7A039B	HOUSING, REAR OUTPUT REAR HALF - FORD
85	3821395		SEAL - REAR OUTPUT
86	4210973		SEAL, REAR OUTPUT YOKE SPLINE (RUBBER)
87	2954140		NUT, REAR YOKE
88	2043		

KITS

T203R	➔ BEARING, GASKET & SEAL KIT
SP203-50	➔ SMALL PARTS KIT
GS203-55	➔ GASKET SET
K203	➔ GASKET & SEAL KIT
K203A	➔ GASKET & SEAL KIT - FORD
13624	➔ CHAIN AND SPROCKET KIT (2" CHAIN)
501	➔ PART TIME KIT - SUPERWINCH
501M	➔ PART TIME KIT - MILEMARKER
502	➔ 501 KIT - 9790R HUBS
502M	➔ 501M KIT - 9790R HUBS



**Motive
Gear®**

NP205 STYLE

DODGE® 69-79, FORD® 69-79, GM® 69-91

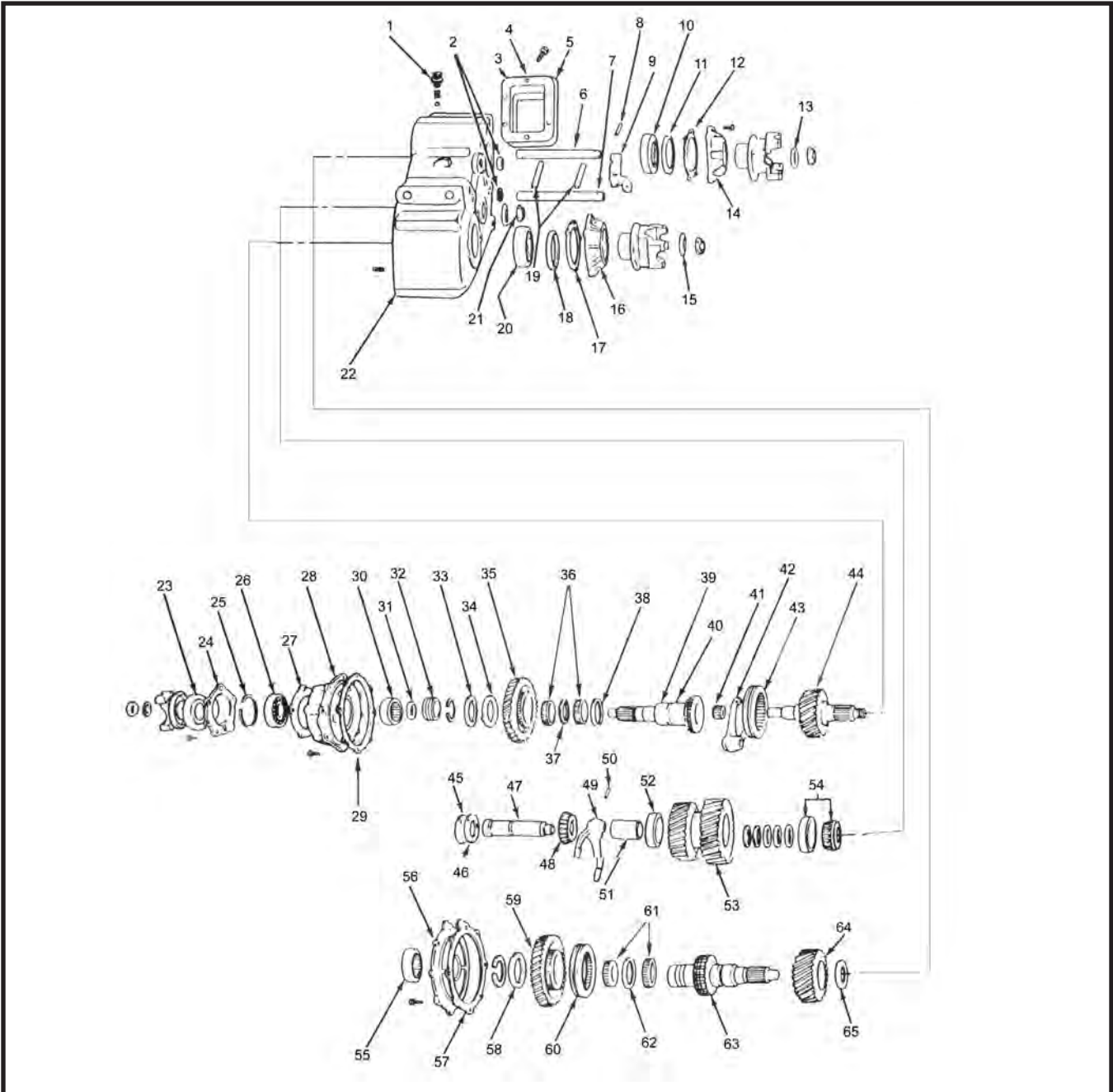

ILL #	MIDWEST #	REF #	REPLACEMENT PART DESCRIPTION
1	1092545		GASKET, SHIFT POPPET
3	1673185		BOLT, PTO COVER
4	517351		GASKET, PTO COVER
5	NV35662		COVER PTO
6	3732039		RAIL, REAR SHIFT CHEVY/DODGE*
6	11405		RAIL, REAR SHIFT FORD*
7	4210978		RAIL, FRONT SHIFT CHEVY/DODGE
7	11406		RAIL, FRONT SHIFT FORD
9	3732041		LINK, SHIFT RAIL "Y" SHAPED LINK
10	1307L		BEARING - INPUT (EXC. BELOW)
10	1210L		BEARING - INPUT HD CHEVY - 32 SPL. INPUT
12/17	927395		GASKET - BEARING RETAINER
13/15	4210973		SEAL - SPLINE

NP205 STYLE (cont.)

ILL #	MIDWEST #	REF #	REPLACEMENT PART DESCRIPTION
13A/15A	2954140		NUT - INTERMEDIATE SHAFT
14	13492		RETAINER - FRONT BEARING CHEVY 1978-ON
14	4167727		RETAINER - FRONT BEARING DODGE/FORD
16	97836		RETAINER, FRONT OUTPUT PILOT, CHEVY 1979-ON
16	2954130		RETAINER, FRONT OUTPUT PILOT, DODGE/FORD - ALL - CHEVY TO 1978
19	2954138		PLUNGER - SHIFT INTERLOCK
22	N/A		CASE, CALL - APPLICATION
23	473468		SEAL, REAR OUTPUT
23	471424		SEAL - ADAPTER CHEVY - TH350
23	473214		SEAL - ADAPTER CHEVY - TH400-SM465
23	482163N		SEAL - ADAPTER DODGE - DIESEL
24	2954134		RETAINER, REAR OUTPUT BEARING
25	2124518		SNAP RING
26	307L		BEARING, REAR OUTPUT
28	4219097		HOUSING, M/S SUPPORT DODGE 1980-ON
29	2225039		GASKET, REAR OUTPUT BEARING RETAINER
30	SCE3216		NEEDLE BEARING, REAR OUTPUT
N.I.	4210975		PIN, FRONT & REAR RETAINER
32	2225024		GEAR, SPEEDO DRIVE 4T
32	2830731		GEAR, SPEEDO DRIVE 5T
32	3732038		GEAR, SPEEDO DRIVE 5T - "Y" SHAPED LINK NYLON - DODGE, GMC
32	627399T		GEAR, SPEEDO DRIVE 7T, RED - GM
33	2954113		WASHER, LOW SPEED THRUST
34	2287		SEAL, SHIFT SHAFT
35	2952589		GEAR, LOW SPEED FRONT & REAR
36/61	QBR23549		NEEDLE BEARING, LOW SPEED (128 REQ.)
37/62	2954112		SPACER, LOW GEAR NEEDLE
38/34	2952591		WASHER, HIGH SPEED THRUST 1973-ON
38/34	3491202		WASHER, HIGH SPEED THRUST 1970-73
39	4106561		SHAFT, REAR OUTPUT - DODGE & FORD
39	11391		SHAFT, REAR OUTPUT w/o GEAR
39	3491281		SHAFT, REAR OUTPUT 1982-83 DODGE
39	13953		SHAFT, REAR OUTPUT 1984-92 GM - MANUAL TRANSMISSION
39	11414		SHAFT, REAR OUTPUT 1984-92 GM - AUTOMATIC TRANSMISSION
40	2952592		PIN, LOW GEAR THRUST WASHER (2 REQ.)
41	QAR29523		NEEDLE BEARING, REAR OUTPUT PILOT (15 REQ.)
42/49	2954135		FORK, MODE AND RANGE SHIFT
43	2954116		CLUTCH, MODE AND RANGE SHIFT
44	16047		INPUT, CHEVY 1985-ON (15594158), 10" W/T400 & SM465
44	13929		INPUT, CHEVY 1981-84, 32 SPL. FEMALE W/ 400
44	11401		INPUT, CHEVY 1969-80, 27 SPL. - AUTOMATIC (MALE) W/ 350
44	99646		INPUT, CHEVY 1969-84, 10 SPL. MALE
44	2954104		INPUT, DODGE 1969-80, REMOTE MOUNT, FORD REMOTE MOUNT - 9-1/8" O.A., 25-34 - 32 SPL.
44	4167905		INPUT, DODGE 1981-93, AUTO TRANS, DIRECT MOUNT 23 SPL. w/o DIESEL
44	4505316		INPUT, DODGE 1989-93, DIESEL, DIRECT MOUNT 29 SPL.
44	11656		INPUT, FORD 1977-79, 7-13/32" O.A., 31 SPL.
45	927365		COVER, INTERMEDIATE SHAFT
46	927364		GASKET, INTERMEDIATE SHAFT COVER
47	2954122		SHAFT, INTERMEDIATE (IDLER)
48	2720 & 2793		BEARING CUP-CONE IDLER GEAR
49			FORK, MODE AND RANGE SHIFT
50	4036691		ROLL PIN, SHIFT FORK
51	2954121		SPACER, IDLER GEAR BEARING
53	2954119		IDLER GEAR - DODGE, FORD - ALL - GM 1969-80
53	14037910		IDLER GEAR 1981-86 GM ONLY
55	M28161		BEARING, FRONT OUTPUT PILOT
59	2952589		HIGH GEAR (35T)
59	2954124		HIGH GEAR (25T)
60	2954116		CLUTCH, SLIDING
63	3491281		SHAFT, FRONT OUTPUT, DODGE/FORD - ALL - CHEVY 1969-78
63	13363		SHAFT, FRONT OUTPUT, CHEVY 1979-81 - MANUAL HUBS - 2ND DESIGN
63	14037911		SHAFT, FRONT OUTPUT, CHEVY 1982-86 - AUTO HUBS
64	14037912		HIGH GEAR, CHEVY - 1982-ON - AUTO HUBS
64	2954124		HIGH GEAR, DODGE/FORD - ALL - CHEVY TO 1981 - ALL - 1982-ON MANUAL HUBS

NP205 STYLE (cont.)

KITS

T172R	➔	BEARING, GASKET & SEAL KIT - 1307L INPUT BRG.
T172RHD	➔	BEARING, GASKET & SEAL KIT - 1210L INPUT BRG.
SPTC205-50	➔	SMALL PARTS KIT
GS205-55	➔	GASKET SET
K205	➔	GASKET & SEAL KIT FORD - DODGE & GM
6259656R	➔	COUPLER - GM 10 SPL. 4-1/4" O.A.
6273964R	➔	COUPLER - GM 27 SPL.
4505302	➔	COUPLER - DODGE 29 SPL., w/ G360 UNIT

NV136 STYLE

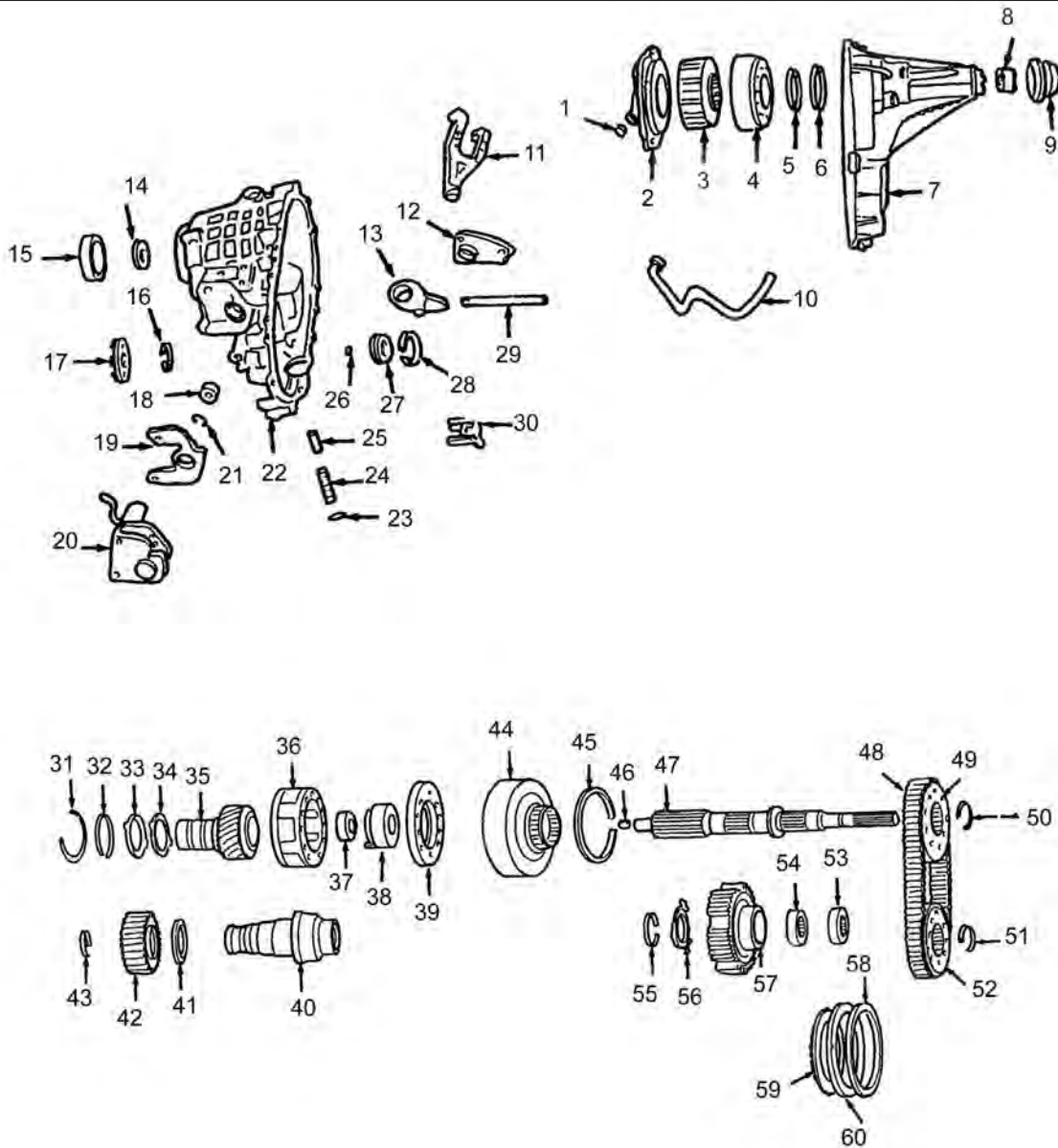

ILL #	MIDWEST #	REF #	REPLACEMENT PART DESCRIPTION
2	NV16686		OIL PUMP
4	6307R-8/3BN		BEARING, M/S REAR
7	NV22503		REAR CASE HALF
9	NV22507		SEAL - OUTPUT - REAR
9	NV22452		SEAL - FRONT - OUTPUT
10	NV16218		OIL TUBE
14	NV22441		SEAL - INPUT
15	6010		INPUT BEARING
20	NV25410		SECTOR ASSY
22	NV22437		FRONT CASE HALF
24	NV16962		SPRING POPPET
25	NV22511		SCREW - POPPET
27	NV25794		TOONE WHEEL
30	NV16217		OIL SCREEN
35	NV22453		INPUT SHAFT
37	DB59856		BEARING, INPUT POCKET
38	12546725		CLUTCH HUB
39	12474070		PRESSURE PLATE - CLUTCH
40	NV22447		SHAFT - FRONT OUTPUT
42	NV22449		TOONE WHEEL - FRONT OUTPUT

NV136 STYLE (cont.)

ILL #	MIDWEST #	REF #	REPLACEMENT PART DESCRIPTION
44	12384942		CLUTCH HOUSING
45	12547606		RETAINING RING
47	NV34710		MAIN SHAFT ASSY
48	HV062		CHAIN
49/52	NV31268		SPROCKET
54/53	FC69343		BEARING, CLUTCH HUB
56	12474069		CLUTCH SPRING
57	12547479		CLUTCH HUB
58	NV29780		SHIM - CLUTCH PLATE
59	NV27747		CLUTCH PLATE - FRICTION (8 REQ.)
60	4461047		CLUTCH PLATE - STEEL (7 REQ.)
N.I.	207		FRONT OUTPUT BEARING
N.I.	SCE2416		FRONT OUTPUT BEARING - REAR
N.I.	6011		MAIN SHAFT FRONT BEARING
N.I.	NV22512		SPEED SENSOR

KITS

TC136R	→	BEARING, GASKET & SEAL KIT
K136	→	GASKET & SEAL KIT

Motive Gear®

MOTIVE GEAR supplies the most durable and reliable ring and pinions in the market.

When you need unmatched performance you need MOTIVE GEAR!

NV149 STYLE
GM® FULL TIME FULL SIZE TRUCK, SILVERADO,
SS AND GMC® SIERRA DENALI

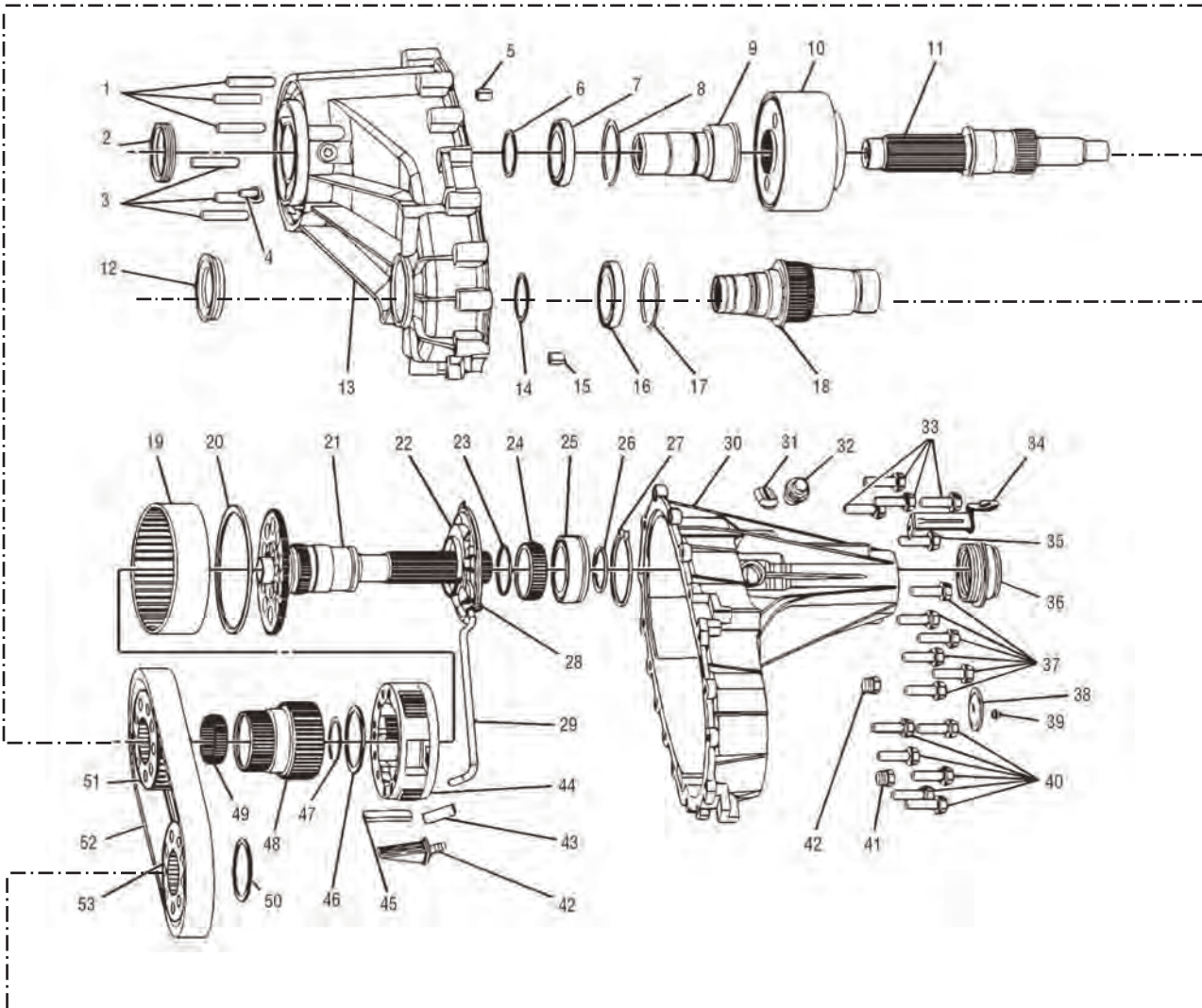

Motive
Gear®

NV149 STYLE (cont.)

ILL #	MIDWEST #	REF #	REPLACEMENT PART DESCRIPTION
2	450316	12547466	INPUT SEAL
12	NV22507	12547638	OUTPUT SEAL - REAR
13	NV32486	12478150	FRONT CASE HALF
6	682653		INPUT BEARING SNAP RING - FRONT
7			INPUT BEARING
8	NV16442	12547465	INPUT BEARING SNAP RING - REAR
9	NV38704	12478151	INPUT SHAFT
10	NV32475	12478157	VISCOUS COUPLER
11	NV31869	12478161	OUTPUT SHAFT - REAR
14	628653		RETAINING RING - FRONT OUTPUT SHAFT
16			FRONT OUTPUT BEARING
17	NV16442	12547465	RETAINING RING - FRONT OUTPUT SHAFT (REAR)
18	NV29057	12478153	FRONT OUTPUT SHAFT
19	NV23386	12478162	CARRIER GEAR - ANNULUS
20	NV27561	12478163	ANNULUS GEAR
21	NV39467	12478154	MAINSHAFT
22	NV29074	12478164	OIL PUMP
23	NV23790	12478168	LOCK RING
24	NV26075	12472605	SPEED GEAR
25			REAR OUTPUT BEARING
26	68253		FRONT OUTPUT BEARING - RETAINING RING (INNER)
27	NV22506	12547637	FRONT OUTPUT BEARING - RETAINING RING (OUTER)
28		12478088	OIL PUMP BODY OIL SEAL
29	NV29748	12478167	OIL TUBE
30	NV30961	12473226	CASE HALF - REAR
32	NV22512	12376520	SPEED SENSOR
36	NV22507	12547638	REAR SEAL
42	NV29747	12478166	OIL PUMP PICK-UP FILTER
44	NV32798	12478160	PLANETARY CARRIER
45	NV30510	12478165	MAGNET
46	NV29067	12478158	SUN GEAR THRUST WASHER
47	NV27561	12478163	SNAP RING
48	NV31681	12478155	SUN GEAR
49		12478156	SUN GEAR BEARING
50	88892217		RETAINING RING
51	NV31269	12474614	DRIVE SPROCKET
52	HV072	12474602	CHAIN (1-1/4" WIDE)
53	NV31269	12474614	DRIVEN SPROCKET
N.I.	WT297-62		REAR BUSHING

KITS

T196R

→ BEARING, GASKET & SEAL KIT

NV231 / 233 STYLE CHEVY®/JEEP® 1987-02 DODGE® 1988-97

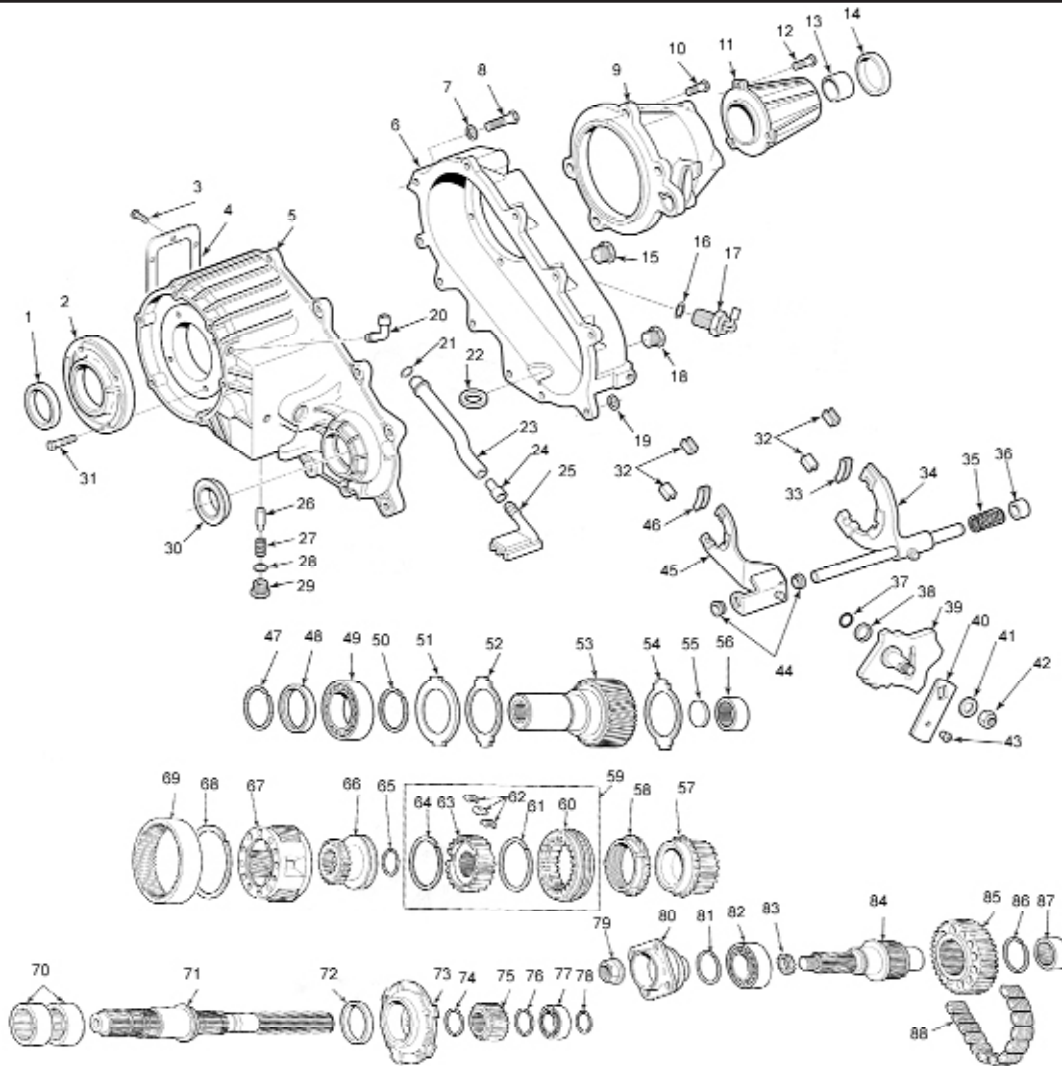

ILL #	MIDWEST #	REF #	REPLACEMENT PART DESCRIPTION
1	3173		SEAL - INPUT (2 REQ.)
2	4338972		RETAINER - FRONT - JEEP® 1987-96, 1988 ALL DODGE
2	4338973		RETAINER - FRONT - DODGE® 1989-96
2	15579798		RETAINER - FRONT - CHEVY 1988-97
5	NV16165	4338887	CASE HALF, FRONT - DODGE 1988-89
5	NV17026	53008220	CASE HALF, FRONT - DODGE 1989-90, JEEP SJ, MJ 1990-93 (NO SWITCH)
5	NV16562	83503572	CASE HALF, FRONT - JEEP YJ 1987-90 - (VACUUM SWITCH HOLE)
5	NV16421	83503121	CASE HALF, FRONT - JEEP XJ, MJ 1987-90 (NO VACUUM SWITCH HOLE)
5	NV17027	53008214	CASE HALF, FRONT - JEEP YJ 1990-97, DODGE 1991-93 (W/ SWITCH)
5	NV20356	4798111	CASE HALF, FRONT - DODGE 1997
5	NV20357		CASE HALF, FRONT - JEEP W/ C16118 W/ SHARP TOOTH RING GEAR
5	NV17932	4796949	CASE HALF, FRONT - DODGE 1994-96, JEEP 1994-96 - 23 SPL.
5	NV16420	15579786	CASE HALF, FRONT - CHEVY 1988-91
5	17413	15664911	CASE HALF, FRONT - CHEVY 233 - 1994
5	NV16983	15635347	CASE HALF, FRONT - CHEVY 231 - 1991-92
5	NV17614	12545954	CASE HALF, FRONT - CHEVY 233 - 1992
5	NV17411	15664908	CASE HALF, FRONT - CHEVY 231 - 1993-96
5	NV17929	12546932	CASE HALF, FRONT - CHEVY 233 - 1995
5	NV19046	12382636	CASE HALF, FRONT - CHEVY 233 - 1996-97
5	NV19052	12383601	CASE HALF, FRONT - CHEVY 233 - 1996-97
6		4505527	CASE HALF, REAR DODGE® 1987-92

NV231/233 STYLE (cont.)

ILL #	MIDWEST #	REF #	REPLACEMENT PART DESCRIPTION
6	NV17393	4741242	CASE HALF, REAR DODGE 1993-97, JEEP® SJ, ZJ 1994-96 - (C16117AT)
6	83503153		CASE HALF, REAR JEEP® 1988-93 - (C16117AE)
6	NV17872	4796902	CASE HALF, REAR JEEP 1994-ON, CHEVY - ALL - (C16117AT)
8	4210617		SCREW, CASE
9	NV16220	4338949	REAR RETAINER, DODGE 1988-90, JEEP XJ, MS 1990-93
9	NV16564	83503573	REAR RETAINER, DODGE 1991-93, JEEP YJ, ZJ 1987-96, XJ 1994-96
9	NV17391	4741243	REAR RETAINER, DODGE 1994-97 DAKOTA
9	NV17794	4746266	REAR RETAINER, DODGE 1994-97 RAM
9	NV16632	15580222	REAR RETAINER, CHEVY 1988-92 EXT. CAB P/U
9	NV17266	15636634	REAR RETAINER, CHEVY 1993-96 STD. CAB P/U
10	4210617		BOLT - EXTENSION
N.I.	4006047		CLAMP - VENT TUBE
N.I.	4338962		WASHER, FRONT OUTPUT NUT
N.I.	4446487		WASHER, SPLINE SEAL
11	4338953		EXTENSION HOUSING - DODGE 1988-97 (3 BOLT)
11	4746150		EXTENSION HOUSING - DODGE RAM 1993-97 CHEVY EXT. CAB P/U (4 BOLT)
11	83503156		EXTENSION HOUSING - JEEP - ALL - CHEVY STD. CAB P/U
11	15579813		EXTENSION HOUSING - CHEVY 1988-92
11	15665311		EXTENSION HOUSING - CHEVY 1993-ON
N.I.	4210614		BOLT - CASE DOWEL
12	6500318		SCREW, REAR RETAINER
13	2801726		BUSHING - REAR EXTENSION, DODGE - ALL - JEEP 1994-96
13	8134490		BUSHING - REAR EXTENSION, JEEP (EXC. BELOW)
13	4338445		BUSHING - REAR JEEP
13	WT266-62		BUSHING - REAR CHEVY, 27 SPL.
13	WT297-62		BUSHING - REAR CHEVY, 32 SPL.
14	4370N		SEAL - REAR JEEP
14	2506		SEAL - REAR DODGE
14	9613S		SEAL - REAR CHEVY
N.I.	4169633		VACUUM SWITCH - DODGE V8, 1988-89
N.I.	53001101		VACUUM SWITCH - DODGE 1990-92, JEEP 1987-96
17	J8134473		ELECTRICAL SWITCH - JEEP 1994-96
17	15664811		ELECTRICAL SWITCH - CHEVY - 3 PRONG
17	15598481		ELECTRICAL SWITCH - CHEVY - 2 PRONG
20	4213328		CAP - VENT HOSE
21	4210983		WASHER - DOWEL
22	8134488		RING, RETAINING - JEEP 1987-96, CHEVY 1988-91, EXT. CAB, P/U 1992-93
22	4746266		RING, RETAINING - DODGE RAM 1994-97
23	4338957		VENT TUBE
N.I.	4338941		TUBE, OIL PICKUP
24	4443176		HOSE - VENT (AS REQUIRED)
25	NV16217		OIL PUMP FILTER
27	4338899		SPRING, DETENT PLUNGER
28	4338900		O-RING
29	1798191		PLUG, SHIFT DETENT PLUNGER
N.I.	710046		SEAL, FRONT OUTPUT
N.I.	4338919		BUSHING, RANGE FORK (PLASTIC)
30	4446496		SLINGER, YOKE
N.I.	4338923		ROLL PIN, MODE FORK
N.I.	4446494		YOKE - FRONT OUTPUT, DODGE 1987-97, JEEP 1991-96
N.I.	83502829		YOKE - FRONT OUTPUT, JEEP, GRAND CHEROKEE, WRANGLER 1987-96
N.I.	83503161		YOKE - FRONT OUTPUT, JEEP, CHEROKEE, WAGONEER, WRANGLER
31	6500318		BOLT - FRONT RETAINER
32	4167969		FORK PAD, TIPS (4 REQ.) - CAN USE 15866
33	4219073		FORK PAD, MODE CENTER - CAN USE 15866
34	4338920		SHIFT FORK-RAIL, MODE DODGE® 1988-93, JEEP 1987-96
34	4741237		SHIFT FORK-RAIL, MODE DODGE® 1994-96, JEEP 1994-96, GRAND CHEROKEE
34	4746136		SHIFT FORK - RAIL, MODE DODGE 1997-ON - C17769
34	4778690		SHIFT FORK - RAIL, MODE CHEVY 231, 1988-90
34	NV24668		SHIFT FORK - RAIL, MODE CHEVY 233 (IRON) - C17178
34	4338894		SNAP RING
35	4338925		SPRING, MODE FORK
36	4338945		BUSHING, SHIFT RAIL
36	4338933		RING, RETAINING - DODGE 1988-90 - JEEP 1994-97
36	83503144		RING, RETAINING - DODGE 1990-93, JEEP 1987-93
N.I.	4338860		PLATE, SYNCHRO KEY & SPRING RETAINER
37	4167963		O-RING
38	4167964		O-RING RETAINER
39	4338895		SHIFT SECTOR - DODGE 1988-92

NV231/233 STYLE (cont.)

ILL #	MIDWEST #	REF #	REPLACEMENT PART DESCRIPTION
39	4638844		SHIFT SECTOR - JEEP 1992-96
39	53008215		SHIFT SECTOR - DODGE 1990-92, JEEP 1988-91
N.I.	4338942		O-RING
40	4338763		LEVER, SHIFT - GROMMET
42	152345		NUT
44	4338898		PLUNGER, SHIFT DETENT
45	4638913		RANGE FORK - DODGE, JEEP - ALL, CHEVY 231
45	12546934		RANGE FORK - CHEVY 233
46	4338376		FORK PAD, RANGE CENTER - CAN USE 15866
49	BD50-8NRC3		INPUT BEARING - EARLY 1987-94 WIDE
49	6010NR		INPUT BEARING - LATE 1995-ON THIN
50	83503527		RETAINING RING
53	4338911		INPUT SHAFT - DODGE - 23 SPL.
53	4505526		INPUT SHAFT - DODGE - 53T-29 23 spl. 5" O.A., 1.94" O.D., 1.20" I.D. 1989
53	53006085		INPUT SHAFT - DODGE 1990-97, JEEP YJ 1987-93, 53T-29 - 23 SPL., 5-1/6" O.A., 1.16" O.D., 1.937" I.D., 1990-97
53	83503159		INPUT SHAFT - JEEP YJ, XJ, MJ, 1987-90, 53T-29 21 SPL. 4-1/8" O.A.
53	83505553		INPUT SHAFT - JEEP YJ, 1987-90, 53T-29 23 SPL.
53	83506065		INPUT SHAFT - JEEP YJ, XJ, MJ, 1987-96, 53T-29 23 SPL. 4-1/8" O.A.
53	53006083		INPUT SHAFT - JEEP YJ, XJ, MJ, 1987-96, 53T-29 21 SPL. 4-1/8" O.A.
53	4796965		INPUT SHAFT - DODGE - JEEP, 1993-96 AUTOMATIC, 53T, -29-23 SPL., 5-1/16" O.A.
53	4798126		INPUT SHAFT - DODGE, 1994-96, 23 SPL.
53	15636629		INPUT SHAFT - CHEVY, 1988-94, 53T-29 27 SPL.
53	12548012		INPUT SHAFT - CHEVY 231, 1995-ON, 27 SPL.
53	12548147		INPUT SHAFT - CHEVY 233, 1995-ON, 27 SPL.
53	NV17822	4761192	INPUT SHAFT - JEEP
56	SCH1810		NEEDLE BEARING, INPUT POCKET
56	FC66561		NEEDLE BEARING, INPUT POCKET - LATE
57	NV19042		DRIVE SPROCKET
57	NV19043		DRIVE SPROCKET w/ LARGE MODE ASSY, 30T
57	NV16206		DRIVEN SPROCKET - JEEP W/ SHAFT
57	NV19042		DRIVEN SPROCKET - DHD W/ 1-1/4" CHAIN
57	NV19041		DRIVEN SPROCKET W/ AUTOMATIC, 1994-2000 DAKOTA
57	NV19043		DRIVEN SPROCKET W/ LARGE MODE ASSY (30T)
58	4329526		SYNCHRO RING - CHEVY 48T, 1988-97
59	4796967		SYNCHRO ASSY - MODE 48T, 1988-97
N.I.	3681601		MAGNET
61	4329524		SYNCHRO SPRING - 1988-97 (2 REQ.)
66	4796906R		RANGE HUB - CHEVY-DODGE-JEEP 1991-96, 29T, 34 SPL. 2.8" O.D., 1.775" I.D., 2.41" O.A. - DIAM. SHAPED TEETH (231)
66	4797013		RANGE HUB 1991-97 CHEVY, JEEP 1997, DODGE RAM 1994-97(231)
66		NV17260	RANGE HUB - CHEVY (233 UNIT)
67	4338901		PLANETARY ASSY - 1988-89
67	53006087		PLANETARY ASSY - 1987-96, LIGHT DUTY - ALL (3 GEARS) 2.8L ENGINE
67	4796903		PLANETARY ASSY - DODGE, 1994-97 AUTO TRANS., JEEP CHEROKEE / WRANGLER 1994-01
67	15636627		PLANETARY ASSY - CHEVY 1988-93, 4.3L, 29T, 19T X 4 GEARS 5-7/16" O.D., 2.365" I.D.
67	12548011		PLANETARY ASSY - 1994 CHEVY, 4.3L
68	4338910		SNAP RING, PLANETARY - 1988-97
69	4338909		LOCK RING, PLANETARY - 1988-97
70/77	206		BEARING M/S REAR
70/77	207		BEARING M/S REAR - LATE
71	4338927		MAIN SHAFT, DODGE 1987-92 - 34-37-38-13, 26 SPL., 1.120" O.D. 18" O.A.
71	NV16201	83503141	MAIN SHAFT, JEEP 1987-96, 34-37-38-13, 27 SPL. 15-7/8" O.A., 1.9675" DIA
71	NV17610		MAIN SHAFT, DODGE, 27 SPL.
71	4796907		MAIN SHAFT, JEEP, 1994-96, 2.2780" DIAMETER - NO SPEED BEARINGS UNDER GEARS, 15-3/4"
71	15636632		MAIN SHAFT, CHEVY 1988-93, EXT. CAB P/U 34T, 33-37, 24 SPL., 15.25" O.A.
71	15636633		MAIN SHAFT, CHEVY 1992-94, 18-1/2" O.A.
71	12547999		MAIN SHAFT, CHEVY 1995-ON
71	NV20362		MAIN SHAFT, 1997 WRANGLER, 17.5" O.A.
72	4210603 / NV16206		SEAL, OIL PUMP 1987-02, DODGE DAKOTA
73	4338936		OIL PUMP HOUSING - CHEVY - DODGE 1988-97, JEEP 1987-02
79	4338963		NUT, FRONT YOKE
N.I.	4338944		COUPLER, TUBE TO SCREEN
81	3821558		SNAP RING

NV231/233 STYLE (cont.)

ILL #	MIDWEST #	REF #	REPLACEMENT PART DESCRIPTION
82	206		BEARING, FRONT OUTPUT SHAFT
84	NV16206	4338934	FRONT OUTPUT SHAFT - SPROCKET, CHEVY 1988-93 - 2.8L, 1-1/8" CHAIN 1988-97, DODGE, DAKOTA 1"
84	4636965		FRONT OUTPUT SHAFT - SPROCKET, CHEVY 1988-94 - 4.3L 1-3/8" CHAIN 1991-97
84	12544076		FRONT OUTPUT SHAFT - SPROCKET - LATE CHEVY, 1-3/8" CHAIN 1995-97
85	4636963		DRIVE SPROCKET - DODGE 1987-92, JEEP 1987-ON, CHEVY 1987-92 - 1" CHAIN, 24T - 24 SYN. TEETH, 3.602" O.D., 2.29" I.D. w/ BRG.
85	15579803		DRIVE SPROCKET - CHEVY 1988-96 - 1-1/4" CHAIN 4.3L V6
85	4636964		DRIVE SPROCKET - DODGE 1991-92 - 1-3/8" CHAIN
85	NV19041		DRIVE SPROCKET W/ 1" CHAIN - DODGE DAKOTA
86	120394		SNAP RING
87	SCE2416		NEEDLE BEARING, FRONT OUTPUT - REAR 1-7/8" O.D.
87	HK5020NFC		NEEDLE BEARING, DRIVE SPROCKET
88	HV022		DRIVE CHAIN 1-1/4" WIDE (233D)
88	HV027		DRIVE CHAIN 1" WIDE

KITS

T230R	→	BEARING, GASKET AND SEAL KIT - NV233 W/6010N INPUT BEARING
T230RA	→	BEARING, GASKET, AND SEAL KIT - NV233 W/BD50-8 INPUT BEARING
T231R	→	BEARING, GASKET AND SEAL KIT
T231RL	→	BEARING, GASKET AND SEAL KIT - LATE (110L INPUT BEARING)
15866	→	FORK PAD KIT
K231	→	GASKET & SEAL KIT
SP231-50	→	SMALL PARTS KIT

NV236 / NV246 STYLE

CHEVY®, AVALANCHE 2002, BLAZER, P/U, SUBURBAN,
TAHOE 1998-02, SILVERADO 1999-02, TRAILBLAZER 2002

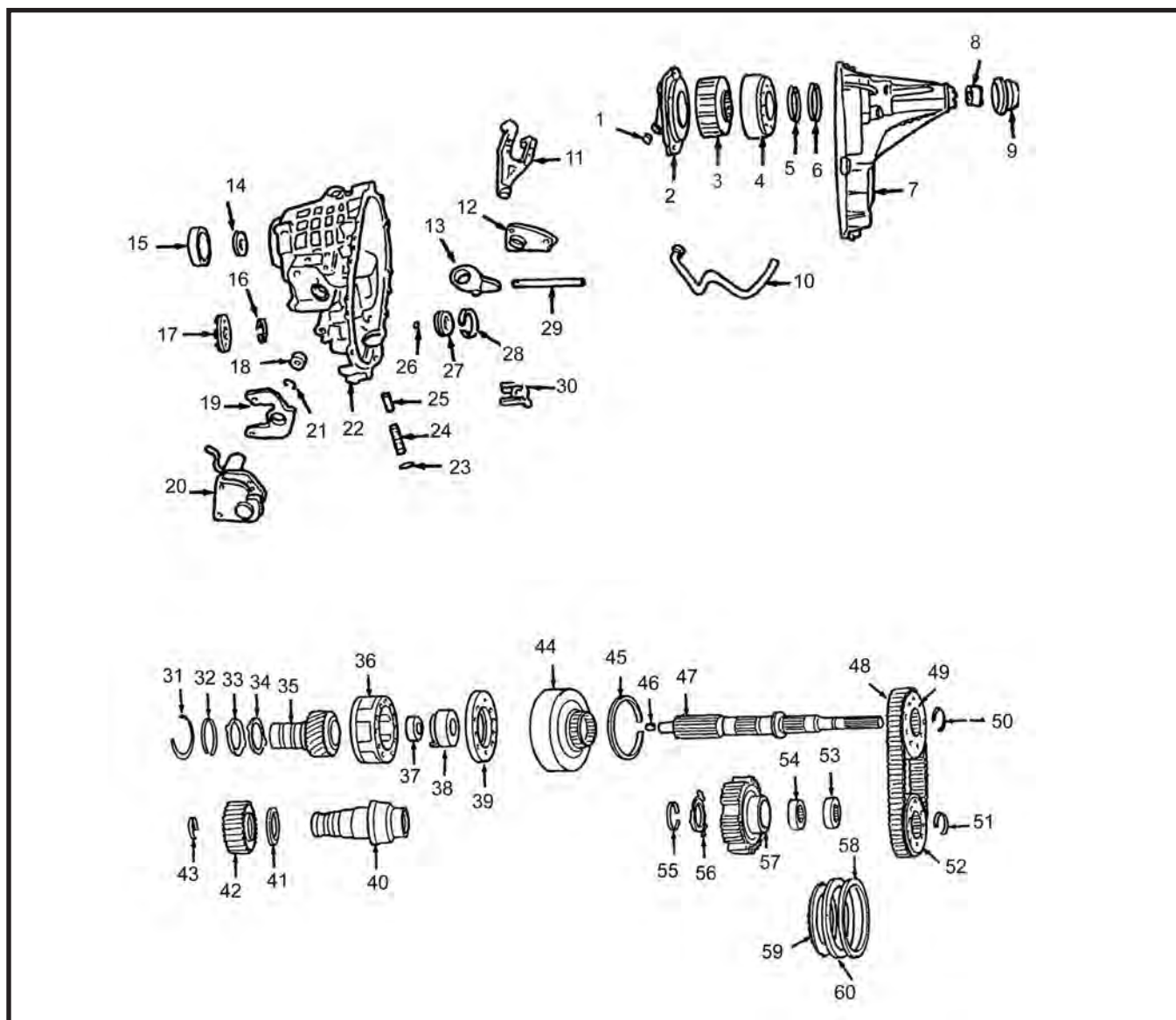

ILL #	MIDWEST #	REF #	REPLACEMENT PART DESCRIPTION
2	NV16686		OIL PUMP
4	573305D		BEARING, M/S REAR
7	NV31334		REAR CASE HALF 236
7	NV30603		REAR CASE HALF 246 - C30605
8	15665313		EXTENSION HOUSING BUSHING
9	NV22507		SEAL - OUTPUT - REAR
10	NV16218		OIL TUBE
11	NV31270		FORK, RANGE 236
11	NV26542		FORK, RANGE 246 W/SPRING ASSY.
13	FC68828		BEARING, SHIFT SHAFT
14	4269183		SEAL - INPUT 246
15	110		INPUT BEARING
17	NV22452	12547478	SEAL - OUTPUT - FRONT 136/236
17	NV30138	12474947	SEAL - OUTPUT - FRONT 246
19	NV30081		LEVER ASSY
22	NV25367		FRONT CASE HALF
22	NV30597		FRONT CASE HALF 246 - C30601

NV236 / 246 STYLE (cont.)

ILL #	MIDWEST #	REF #	REPLACEMENT PART DESCRIPTION
22	NV23733		FRONT CASE HALF 246 (MAGNESIUM)
24	NV22511		SCREW, POPPET
25	NV29781		PLUNGER, POPPET
29	NV23748		RAIL, SHIFT
30	NV16217		SCREEN, OIL
33/34	5012367AA		INPUT THRUST WASHER (PLASTIC)
35	NV19019		INPUT SHAFT ASSY 246 - 32 SPL.
35	NV19020		INPUT SHAFT ASSY 236, 246 - 27 SPL.
36	NV37424		PLANET ASSY - 236
36	NV37425		PLANET ASSY - 246
37	DB59856		BEARING, INPUT POCKET
38	NV17982		SLEEVE - CLUTCH
39	12547624		PRESSURE PLATE - CLUTCH 1998-2000
39	12474440		PRESSURE PLATE - CLUTCH 2000-2001
39	12474070		PRESSURE PLATE - CLUTCH 2001
39	88935703		PRESSURE PLATE - TRAILBLAZER
40	NV22447		SHAFT - FRONT OUTPUT 236
40	NV29733		SHAFT - FRONT OUTPUT 246
42	NV22449		TONE WHEEL - FRONT
44	12384942		CLUTCH HOUSING - EXC. TRAILBLAZER
44	88935698		CLUTCH HOUSING - TRAILBLAZER
45	12547606		RETAINING RING - EXC. TRAILBLAZER
45	12547623		RETAINING RING - TRAILBLAZER
47	NV29012		MAIN SHAFT ASSY, 8 PLATE - 236
47	NV25079		MAIN SHAFT ASSY 246 - MAGNESIUM CASE
47	NV29011		MAIN SHAFT ASSY, 10 PLATE - 246
47	NV22463		MAIN SHAFT ONLY
48	HV062		CHAIN - 236 T/C
48	HV063		CHAIN - 246 T/C - ONE BLUE LINK - 1999 SUV ONLY
48	HV072		CHAIN - 246 T/C - THREE BLUE LINKS - 1999-ON, GMT800 - 2000-ON - FULL SIZE SUV
49/52	NV31268		SPROCKET - 236
49/52	NV31269		SPROCKET - 246
54/53	FC69343		BEARING - CLUTCH HUB
56	12547606		CLUTCH SPRING - EXC. TRAILBLAZER
56	88935702		CLUTCH SPRING - TRAILBLAZER
57	12547497		CLUTCH HUB - EXC. TRAILBLAZER
57	88935699		CLUTCH HUB - TRAILBLAZER
58	NV29780		SHIM - CLUTCH PLATES
59	NV27747		CLUTCH PLATE, FRICTION (UNIT 246 - 10 REQ.), (UNIT 236 - 8 REQ.)
60	4461047		CLUTCH PLATE, STEEL (UNIT 246 - 9 REQ.), (UNIT 236 - 7 REQ.)
N.I.	110		FRONT OUTPUT BEARING - 246
N.I.	HK5020NFC		FRONT OUTPUT BEARING - 246
N.I.	207		FRONT OUTPUT BEARING - 236
N.I.	SCEZ416		FRONT OUTPUT BEARING - 236
N.I.	6011		CLUTCH HOUSING BEARING, CENTER MAINSHAFT BEARING
N.I.	4167969		FORK INSERT
N.I.	4338376		FORK INSERT
N.I.	NV26237		OIL PUMP WEAR CLIP "CASE PROTECTOR"

KITS

TC136R	→	BEARING, GASKET & SEAL KIT 236
T351R	→	BEARING, GASKET & SEAL KIT 246
K236	→	GASKET & SEAL KIT 236
K246	→	GASKET & SEAL KIT 246

NV241 STYLE
CHEVY® 1987-98
DODGE® 100/350 1987-98

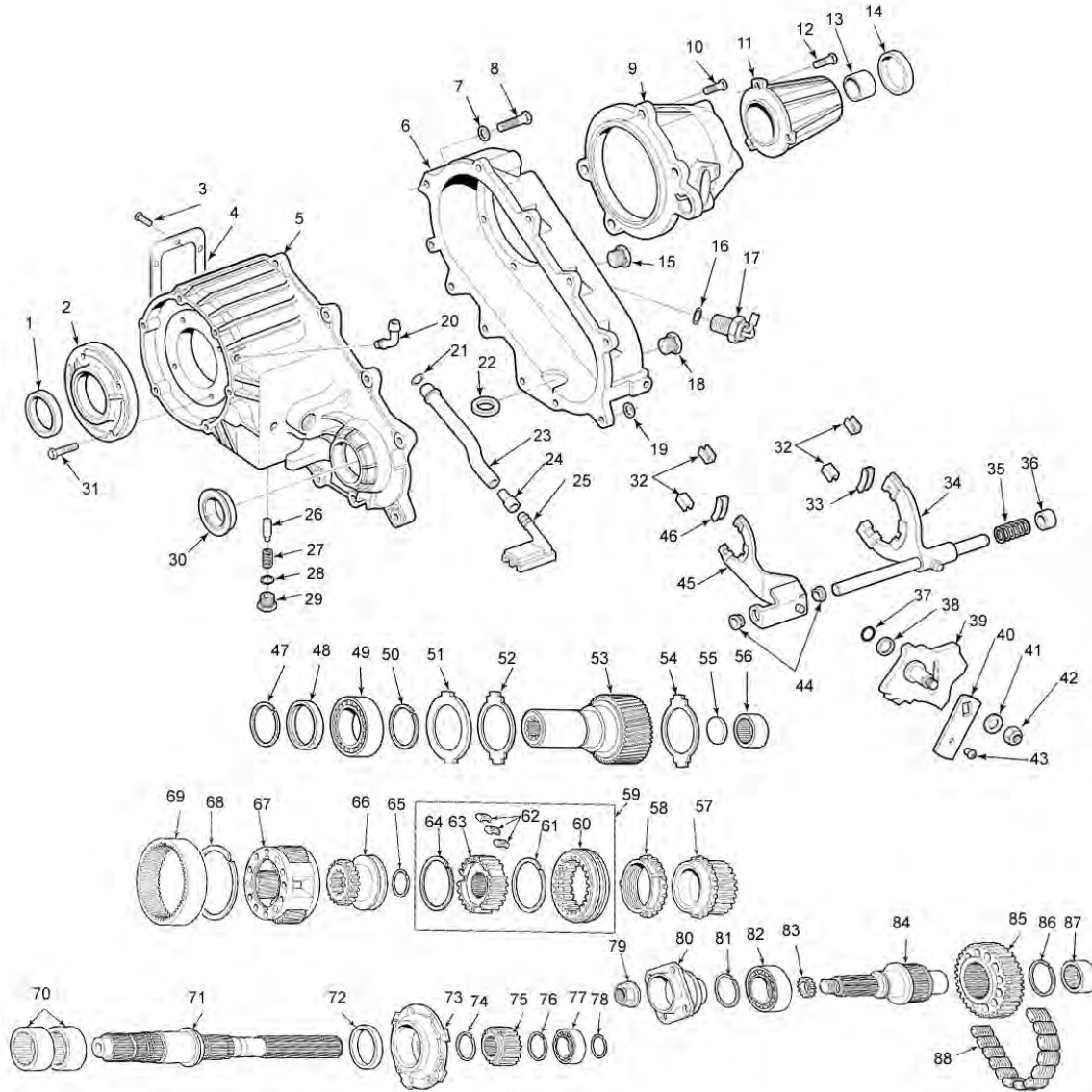

ILL #	MIDWEST #	REF #	REPLACEMENT PART DESCRIPTION
1	3173		SEAL, INPUT
2	NV16423	4338973	RETAINER, INPUT - CHEVY/DODGE - ALL - (EXC. 2002 RAM 1500)
3	N.A.		BOLT, PTO COVER
4	N.A.		COVER, PTO OPENING
5	NV16423	15547374	FRONT CASE HALF - CHEVY/GMC® 1988-89
5	NV17429	15664901	FRONT CASE HALF - CHEVY/GMC 1990-95 - GETRAG
5	NV17456	15662252	FRONT CASE HALF - CHEVY/GMC 1992-95 - (NEW VENTURE 4500 TRANS)
5	12547996		FRONT CASE HALF - CHEVY/GMC 1996-99
5	NV17024	53008219	FRONT CASE HALF - DODGE 1990-92
5	NV17027	53008214	FRONT CASE HALF - DODGE 1993-94
5	NV17800	4746252	FRONT CASE HALF - DODGE 1995-99 STANDARD DUTY
		C17240	
5	NV17512	4746124	FRONT CASE HALF - DODGE 1995-99 HEAVY DUTY C17257
5	N32173	5015449AA	FRONT CASE HALF - DODGE 2000-ON (EXC. BELOW)

NV241 STYLE (cont.)

ILL #	MIDWEST #	REF #	REPLACEMENT PART DESCRIPTION
5	NV40952	5080154AA	FRONT CASE HALF - DODGE 2002 PICK-UP
5	NV32176	5015446AA	FRONT CASE HALF - DODGE 2000-ON HEAVY DUTY
6	NV16254	15547435	REAR CASE HALF - CHEVY/GMC (EXC. BELOW) - C16119
6	NV17458	15662255	REAR CASE HALF - CHEVY/GMC (1999 - MANUAL TRANSM.)
6	4338998		REAR CASE HALF - DODGE 1988-93
6	NV21653	4797550	REAR CASE HALF - DODGE 1992-94 (EXC.BELOW) DHD - C17457
6	NV41902	5080221AA	REAR CASE HALF - DODGE RAM 1500 - 2002
7/19	4210983		WASHER, CASE DOWEL
8	4210617		BOLT, CASE ASSY
9	15547441		RETAINER, M/S REAR, CHEVY 1992-97 - GETRAG, 1988-91 & AUTOMATIC - C16255
9	NV17459	15662257	RETAINER, M/S REAR, CHEVY 1999-2000 - MANUAL TRANS
9	NV16349	4339000	RETAINER, M/S REAR, DODGE 1988-90
9	NV21654	4797551	RETAINER, M/S REAR CHEVY/GMC (EXC. BELOW) DODGE 1993-96
9	NV16188		RETAINER, M/S REAR, DODGE 1995-96 HD, 1997-ON - ALL
9	NV24961		RETAINER, M/S REAR - DHD (SNOUTED w/ 4 BOLTS w/ SPEEDO) C26418
10	6500318		SCREW - REAR RETAINER - NEED CASTING #
11	NV24961		EXTENSION HOUSING, 241 DHD, 4-BOLT w/ SPEEDO - CASTER 26418, 1998-ON
11	NV17477	15665311/4746150	EXTENSION HOUSING, CHEVY (ALL EXC. BELOW)
11	NV17462	15662258	EXTENSION HOUSING, CHEVY 1999-2000 - MANUAL TRANS. NO DHD SPEEDO
11	4798002		EXTENSION HOUSING, DODGE 1988-99 - CAN USE 15665311
11	NV37803	5080386AA	EXTENSION HOUSING, DODGE 2002, RAM 1500
12	4210617		SCREW - EXTENSION HOUSING
13	WT297-62		BUSHING, REAR EXTENSION - CHEVY, DODGE
13	NV18172		REAR BUSHING w/ 31 SPLINE M/S
14	3946		SEAL, REAR OUTPUT - DODGE
14	9449		SEAL, REAR OUTPUT - CHEVY 1988-91
14	4333N		SEAL, REAR OUTPUT - CHEVY 1992-ON - DHD w/32 SPLINE M/S
14	4741		SEAL, REAR OUTPUT - DHD w/31 SPLINE M/S
15/18	NV22398		PLUG, FILL/DRAIN
16	4338956		O-RING - SEAL
17	N.A.		SWITCH - CONTACT VEHICLE MANUFACTURER
20	NV16090	4338957	VENT
21	NV16214	4338942	SEAL, OIL TUBE
22	95472		MAGNET - CHIP CORRECTOR
23	NV16215	4338941	OIL TUBE
24	NV16218	4338944	CONNECTOR - TUBE TO SCREEN
25	NV16217	4338943	SCREEN - OIL
26	53008217		PLUNGER, POPPET
27		53008218	SPRING, POPPET PLUNGER
28	NV15715	4338956	O-RING, POPPET SCREW
29	53008216		SCREW, POPPET
30	3946		SEAL, FRONT OUTPUT
31	6500318		SCREW, FRONT INPUT RETAINER
32	4167969		FORK PADS, TIPS (4 REQ.) - CAN USE 15866
33	4219073		FORK PAD, MODE - CENTER - CAN USE 15866
34	NV16267	15637217	MODE FORK, CHEVY PICKUP 1988-91- C16196
34	NV17025	4778690	MODE FORK, DODGE 1988-93 - C16342, DODGE 1988-93
34	NV17790	4746136	MODE FORK, DODGE 1994-2002 (EXC. BELOW) - C17769
34	5080158AA		MODE FORK, DODGE 2002, RAM 1500
35	NV17556		SPRING, SHIFT RAIL
36			BUSHING, SHIFT RAIL
37	4167963		O-RING, SHIFT SHAFT
38	4167964		RETAINER, SHIFT SHAFT O-RING
39	NV17349		SECTOR AND SHAFT ASSY, CHEVY
39	NV17767		SECTOR AND SHAFT ASSY, DODGE
40	NV17910		SHIFT LEVER ASSY
41	2436163		WASHER, SHIFT LEVER NUT
42	NV13992		NUT, SHIFT LEVER
43			GROMMET, SHIFT LEVER
44	15547404		BUSHING, RANGE FORK TO RAIL
45	NV17833	12544310	RANGE FORK, CHEVY PICKUP C17833
45	4746134		RANGE FORK, DODGE 1994-97
46	4167970		FORK PAD, RANGE - CENTER - CAN USE 15866
47	682653		SNAP RING - INPUT BEARING RETAINING

NV241 STYLE (cont.)

ILL #	MIDWEST #	REF #	REPLACEMENT PART DESCRIPTION
49	BD50-8		INPUT BEARING, DODGE - ALL, CHEVY 1987-94 (THICK)
49	6010NR		INPUT BEARING, CHEVY - 1994-ON (THIN)
50	4338910		SNAP RING, INPUT TO PLANETARY
51	4338909		LOCK RING, PLANET CARRIER
53	15635192R		INPUT SHAFT, GM* - BD50-8 BEARING, - 53T, 29T, 32 SPL., 5.15" O.A., 4L80E
53	15635194R		INPUT SHAFT, GM - BD50-8 BEARING - 53T, 29T, 27 SPL., 1.945" O.D., 1.105" I.D., 4L80E
53	NV19019	12547998	INPUT SHAFT, GM 32 SPL. - 6010NR BEARING
53	NV19020	12548007	INPUT SHAFT, GM 27 SPL. - 6010NR BEARING
53	4505526		INPUT SHAFT, DODGE 5" O.A. 23 SPL. 1988-90
53	53006085		INPUT SHAFT, DODGE 5.1" O.A. 23 SPL. 1991-93
53	2412902R		INPUT SHAFT, DODGE 5" O.A. 29 SPL. 1994-ON HD
53	4746153		INPUT SHAFT, DODGE 5" O.A. 23 SPL. 1994-97 HD
53	5015447AA		INPUT SHAFT, DODGE* 2000-ON, - AUTO TRANS.
53	NV22390		INPUT SHAFT, 23 SPL. - (DHD) w/ 6010N, 5" O.A.
53	NV21288		INPUT SHAFT, 23 SPL. - (DHD) w/ NARROW BEARING AND NARROW TEETH, 4 1/4" O.A.
54/52	4338908		THRUST WASHER, PLANET CARRIER
55	NV15719	53000502	PLUG, INPUT SPLINE
56	FC66561 / SCH1810		BEARING, INPUT POCKET - CHEVY 1991-ON, (SMALL) DODGE
56	SCE2110		BEARING, INPUT POCKET, CHEVY TO 1991 - DODGE - (BIG)
57	4338987		DRIVE SPROCKET - CHEVY 1988-94 (EXC. 1 TON), DODGE TO 1994 34T, 24 SYNCHRO TEETH w/o BEARINGS UNDER GEAR - IF NEEDED USE (2) HK5020NFC
57	12548000		DRIVE SPROCKET - CHEVY 1995-ON (CAN USE NV16247)
57	4746256		DRIVE SPROCKET - DODGE 1995-ON NON-HD (EXC. 2002 RAM)
57	4746142		DRIVE SPROCKET - DODGE 1995-ON HD, 1-1/2" CHAIN
57	5080201AA	NV32179	DRIVE SPROCKET - DODGE 2002 RAM 1500 NON-HD
58	4329526	14071703	SYNCHRO RING - CHEVY ALL, DODGE 1988-93 - 48T
58	4746139		SYNCHRO RING - DODGE 1994-2002 (EXC. BELOW) HEAVY DUTY
58	5080504AA		SYNCHRO RING - DODGE 2002 RAM 1500
59	NV17915	4796967	SYNCHRO ASSY - CHEVY
59	NV17915	4796967	SYNCHRO ASSY - DODGE DLD 1988-93
63	NV17772	4746143	SYNCHRO HUB - DODGE DHD 1994-2002 (EXC. BELOW)
60	NV17773	4746144	SYNCHRO SLEEVE - DODGE DHD1994-2002 (EXC. BELOW)
63	5080504AA		SYNCHRO HUB - DODGE 2002 RAM 1500 (ELEC. SHIFT)
63	5080197AA		SYNCHRO HUB - DODGE 2002 RAM 1500 MANUAL SHIFT
60	5080207AA		SYNCHRO SLEEVE - DODGE 2002 RAM 1500
61/64	4329524	14071702	SYNCHRO SPRING - CHEVY ALL, DODGE TO 1993
61/64	NV17778	4746138	SYNCHRO SPRING - DODGE 1994-2002 (EXC. BELOW)
61/64	NV22451	5080503AA	SYNCHRO SPRING - DODGE 2002 RAM 1500
62	NV15213		SYNCHRO KEY - ALL
65	4338933		SNAP RING - SYNCHRONIZER RETAINING
66	4796906R		RANGE HUB - CHEVY/DODGE TO 1995
66	4746129		RANGE HUB - CHEVY/DODGE DHD,1996-ON (EXC. BELOW) - 21 EXT. TEETH - 34 SPL., 2.24" O.D., 1.76" I.D.
66	4746130		RANGE SLEEVE, DHD
66	5072467AA		RANGE HUB - DODGE 2002 RAM 1500
66	NV17520		RANGE COLLAR SNAP RING (DHD)
67	NV16550		PLANETARY ASSY - CHEVY/DODGE 6 PINION - BD50-8
67	NV17869		PLANETARY ASSY - CHEVY/DODGE 6 PINION - 6010NR
	NV17517		PLANETARY ASSY - DODGE 6 PINION - BD50-8 - PTO
67	NV17944		PLANETARY ASSY - DODGE 6 PINION - 6010NR - PTO
68	4210965		SNAP RING, ANNULUS RING
69	83503122		ANNULUS GEAR - 1988-91 ALL
70	HK5020HFC		NEEDLE BEARING - DRIVE SPROCKET
71	15636633		MAIN SHAFT - CHEVY 1988-94 - 34T
71	12547999		MAIN SHAFT - CHEVY 1995-97, 37-38-32 SPL., 1.37" O.D., 18.5" O.A., 1988-93
71	4338985		MAIN SHAFT - DODGE 1988-93
71	4778949		MAIN SHAFT - DODGE 1994-2001 - 34T - 37-38-32 SPL. 18.5" O.A.
71	4778964		MAIN SHAFT - DODGE* 1994-99 HD - 34T, 37-38-32 SPL. 19.25" O.A.
71	4883579AA		MAIN SHAFT - DODGE 1997-ON HD, 39T, 37-3131, 19.25 O.A.
71	50801804A		MAIN SHAFT - DODGE 2002-ON NON-HD, 1/2 TON RAM
71	5080068AA		MAIN SHAFT - DODGE 2002-ON NON-HD, 3/4 TON
72	341022		SEAL, PUMP ASSY

NV241 STYLE (cont.)

ILL #	MIDWEST #	REF #	REPLACEMENT PART DESCRIPTION
73	NV16209	4338936	OIL PUMP ASSY
N.I.	449212		SCREW, PUMP RETAINING
75	15547433 / 16253		SPEEDO GEAR, TONE WHEEL - CHEVY
75	4338996		SPEEDO GEAR, DODGE (MOST)
76/74	4338997		SNAP RING, SPEEDO GEAR
77	207		BEARING, MAIN SHAFT REAR/OUTPUT CHEVY
77	307L		BEARING, MAIN SHAFT REAR (DLD)
77	207X10		BEARING, MAIN SHAFT REAR (DHD)
77	BB1-1015		BEARING, MAIN SHAFT REAR 1997-ON DODGE - DHD
78	1300139027		SNAP RING, REAR MAIN SHAFT BEARING
79	4167924		NUT, OUTPUT YOKE
80			FLANGE, OUTPUT - CALL - APPLICATION
81	4167991		SNAP RING, FRONT OUTPUT RETAINING
82	207		BEARING, FRONT OUTPUT
83	4210973		SEAL, FRONT OUTPUT SPLINE
84	15547421		SHAFT, FRONT OUTPUT, CHEVY 1988-94
84	12547448		SHAFT, FRONT OUTPUT, CHEVY 1995-2000
84	12473222		SHAFT, FRONT OUTPUT, CHEVY SILVERADO 1999-2002
84	4338991		SHAFT, FRONT OUTPUT, DODGE 1988-90
84	83503517		SHAFT, FRONT OUTPUT, DODGE 1994-2002 NON-HD
			CHEVY 32T - 61 SPL., 8.75" O.A., 1.37" O.D. 1988-94
84	5080211AA		SHAFT, FRONT OUTPUT, DODGE 2002, RAM 1500
84	4746146		SHAFT, FRONT OUTPUT, DODGE 1994, 2002 2500/3500 HD,
84	4728158		SHAFT, FRONT OUTPUT, DODGE, 1995-2001 HD
85	4746259		DRIVEN SPROCKET - CHEVY - ALL, DODGE (EXC. BELOW)
			34T - 61 SPL., FOR SPROCKET 2.58" I.D.
85	5080201AA		DRIVEN SPROCKET - DODGE 2002 RAM NON-HD
85	4746145		DRIVEN SPROCKET - DODGE HD - 1-1/2" CHAIN
86	4167991		SNAP RING, FRONT OUTPUT SPROCKET
87	SCE2416		NEEDLE BEARING, FRONT OUTPUT PILOT
88	HV025		CHAIN, CHEVY - ALL, DODGE LD - 1-1/4" WIDE
88	HV031		CHAIN, DODGE HD - 1-1/2" WIDE
88	HV072		CHAIN, PART TIME ELECTRIC SHIFT, RAM 1500 STANDARD, JUNE 2004 & UP (.375 PITCH X 1-1/4" WIDE X 98 PITCHES)
88	HV081		CHAIN, PART TIME JEEP RUBICON, PART TIME ELECTRONIC SHIFT, RAM 1500 STANDARD 2002 - MAY 2004 (1-1/4" WIDE)

KITS

T241R	→	BEARING, GASKET & SEAL KIT TO 1994
T241RL	→	BEARING, GASKET & SEAL KIT TO 1995-ON
T241RHD	→	BEARING, GASKET & SEAL KIT - DODGE HD
K241	→	GASKET & SEAL KIT

NV243 STYLE

CHEVY® BLAZER, TAHOE, YUKON, SUBURBAN, 4X4 PICKUP (1995-99), DODGE® RAM (2002-UP)

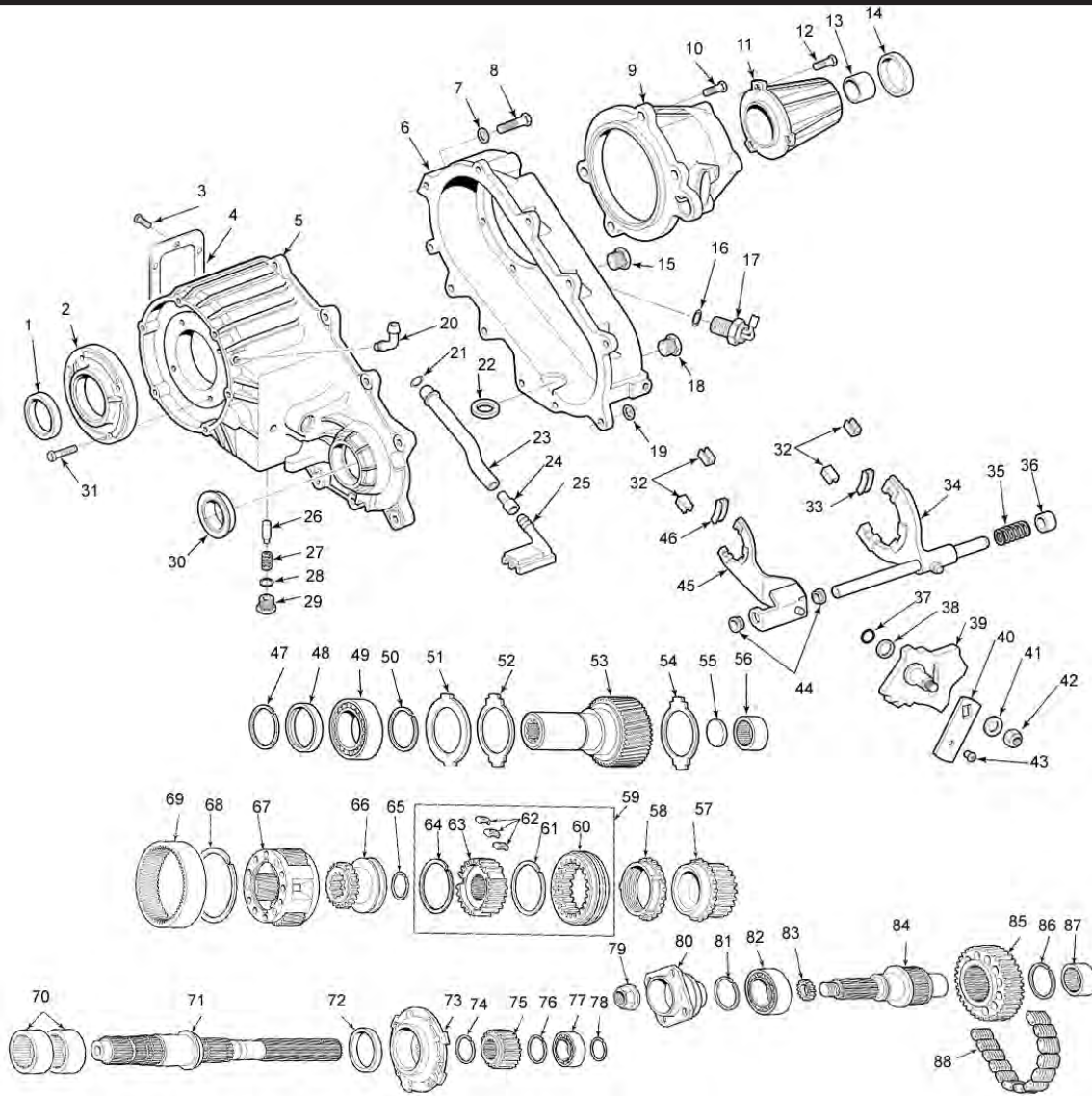

ILL #	MIDWEST #	REF #	REPLACEMENT PART DESCRIPTION
1	3173		SEAL, INPUT
2	NV16244	4338973 / 15547399	RETAINER, INPUT - CHEVY
5	NV40954	5080303AA	FRONT CASE HALF - DODGE*
5	NV24664	12386241	FRONT CASE HALF - CHEVY
6	15547435		REAR CASE HALF - CHEVY
6	5080221AA		REAR CASE HALF - DODGE
8	4210617		SCREW, CASE ASSY
7/19	NV15142	4210983	WASHER, CASE SCREW
9	NV17459	15662257	REAR RETAINER, MAIN SHAFT - CHEVY
10	6500318		SCREW, REAR RETAINER
11	NV17462	4798002	REAR EXTENSION ASSY - CHEVY
11	NV37803	5080386AA	REAR EXTENSION ASSY - DODGE
12	61573	4210617	SCREW, REAR EXTENSION
13	WT297-62	3978765	BUSHING, REAR EXTENSION
14	3946		SEAL - REAR OUTPUT - DODGE*
14	4338N		SEAL - REAR OUTPUT - CHEVY

NV243 STYLE (cont.)

ILL #	MIDWEST #	REF #	REPLACEMENT PART DESCRIPTION
15/18	NV22398		PLUG, FILL/DRAIN
16	NV15715	4338956	O-RING, SWITCH HOLE
17	NV17347	15547452	SWITCH, 3 POSITION - CHEVY SPEED SENSOR
20	NV17988	4796910	VENT
21	NV16214		O-RING SEAL, OIL TUBE
22	95472	3681601	MAGNET - CHIP COLLECTOR
23	NV16215		OIL TUBE, PUMP
24	NV16218		CONNECTOR, SCREEN TO TUBE
25	NV16217		SCREEN, OIL PICKUP FILTER
26	NV16754	53008217	PLUNGER, POPPET
27	NV17071	15636639	SPRING, POPPET PLUNGER
28	NV15715		O-RING, POPPET SCREW
29	NV16756	15633558	POPPET SCREW
30	3946		SEAL, FRONT OUTPUT
31	6500318		SCREW, INPUT RETAINER
32	4167969		FORK PADS, TIPS (4 REQ.)
33	4219073		FORK PAD, CENTER - MODE FORK
34	NV24668	12386244	SHIFT FORK, MODE - TAHOE 1997-ON, 1995-96 15637217
34		15637217	NV231/241 CHEVY MODE FORK - TAHOE 1995-96
35	15636694		SPRING, MODE FORK
36	83503514		BUSHING, SHIFT SHAFT
37	4167963	NV13725	O-RING, SECTOR SHAFT
38	NV13726		RETAINING O-RING
39	12386249		SECTOR, SHIFT - CHEVY
40	NV17407		LEVER, SHIFT
41	15633555		WASHER, SHIFT LEVER
42	NV13992		NUT, SHIFT LEVER TO SHAFT
44	83503514		RETAINING RING (2 REQ.)
45	NV17991	12386243	SHIFT FORK, RANGE (HI-LO), TAHOE 1997-ON, 1995-96 12544310
45		12544310	RANGE FORK GM241C T/C - TAHOE 1995-96
46	4338376		FORK PAD, CENTER - RANGE FORK
47	682653		SNAP RING, INPUT BEARING
49	6010NR		BEARING, INPUT
50	4338910		RETAINING RING
51	4338909		PLANETARY LOCK RING
52/54	4338908		THRUST WASHER
53	NV17978		INPUT SHAFT, CHEVY 27 SPL. - 4L60E TRANS
53	NV17980		INPUT SHAFT, CHEVY 32 SPL.
53	5072464AA		INPUT SHAFT, DODGE RAM 2002
55	9421756		PLUG, INPUT SPLINE
56	FC66561		NEEDLE BEARING - INPUT POCKET
57	NV20939		SPROCKET, CHAIN DRIVE - CHEVY
57	5080201AA	12386245	SPROCKET, CHAIN DRIVE - DODGE
58	NV20938	12386246	SYNCHRONIZER BLOCKING RING
59	NV17915	4796967	SYNCHRONIZER ASSEMBLY, MODE SHIFT
60	NV26082	5080207AA	SYNCHRONIZER SLEEVE
61/64	5019580AB		SYNCHRONIZER SPRING (2 REQ.)
62			SYNCHRONIZER KEY (3 REQ.)
63	5080197AA		SYNCHRONIZER HUB
65	4338933		SNAP RING, SYNCHRONIZER RETAINING
66	NV17982	12386242	SHIFT COLLAR, RANGE - CHEVY
66	5072467AA		SHIFT COLLAR, RANGE - DODGE RAM 2002
67	NV19017	5080157AA	PLANETARY ASSY - DODGE RAM 2002
67	NV17869	12547997	PLANETARY ASSY - CHEVY
68	4210965		LOCK RING, ANNULUS GEAR
69	N.S.S.		ANNULUS RING - MUST PURCHASE FRONT CASE ASSY
70			NEEDLE BEARING, DRIVE SPROCKET
71	NV19014	12547499	MAIN SHAFT, CHEVY
71	5080180AA		MAIN SHAFT, DODGE RAM 2002
72	341022		SEAL, OIL PUMP
73	NV16209	4338936	OIL PUMP ASSY
74/76	4338997		SNAP RING, SPEEDO RING (2 REQ.)
75	NV16253	15547433	TONE WHEEL - CHEVY
77	207		BEARING, REAR OUTPUT
78	4897982AA		SNAP RING, REAR M/S BEARING
79	4167924		NUT, FRONT OUTPUT YOKE
80			YOKE, CALL - APPLICATION

NV243 STYLE (cont.)

ILL #	MIDWEST #	REF #	REPLACEMENT PART DESCRIPTION
81	6025755		SNAP RING, FRONT OUTPUT BEARING
82	204		BEARING, FRONT OUTPUT
83	17821		SEAL, YOKE SPLINE
84	NV17885	12547448	OUTPUT SHAFT, FRONT - CHEVY
84	5080211AA		OUTPUT SHAFT, FRONT - DODGE*
85	NV15307	14037980	SPROCKET, CHAIN DRIVEN - CHEVY
85	5080201AA	4746259	SPROCKET, CHAIN DRIVEN - DODGE
86	4167991		SNAP RING, SPROCKET RETAINING
87	SCE2416		NEEDLE BEARING, FRONT OUTPUT PILOT
88	HV025		CHAIN, CHEVY 1-1/4" WIDE
88	HV072		CHAIN, PART TIME ELECTRIC SHIFT, RAM 1500 OPTIONAL ALL 4 WD - JUNE 2004 & UP (.375 PITCH X 1-1/4" WIDE X 98 PITCHES)
88	HV081		CHAIN, PART TIME ELECTRIC SHIFT, RAM 1500, 2002-MAY 2004 (.4346 PITCH X 1-1/4" WIDE X 84 PITCHES)

KITS

T243R	➔ BEARING, GASKET & SEAL KIT
K243	➔ GASKET & SEAL KIT
SP243-50	➔ SMALL PARTS KIT



Bearing Kits

This catalog has all of our O.E. quality bearing kits associated with manual transmission, transfer case & axle/differential applications. A must have for distributors and rebuilders alike.

NV261/263 (LD) STYLE

CHEVROLET® K1500, K2500, K2500HD, K3500, 2000-ON

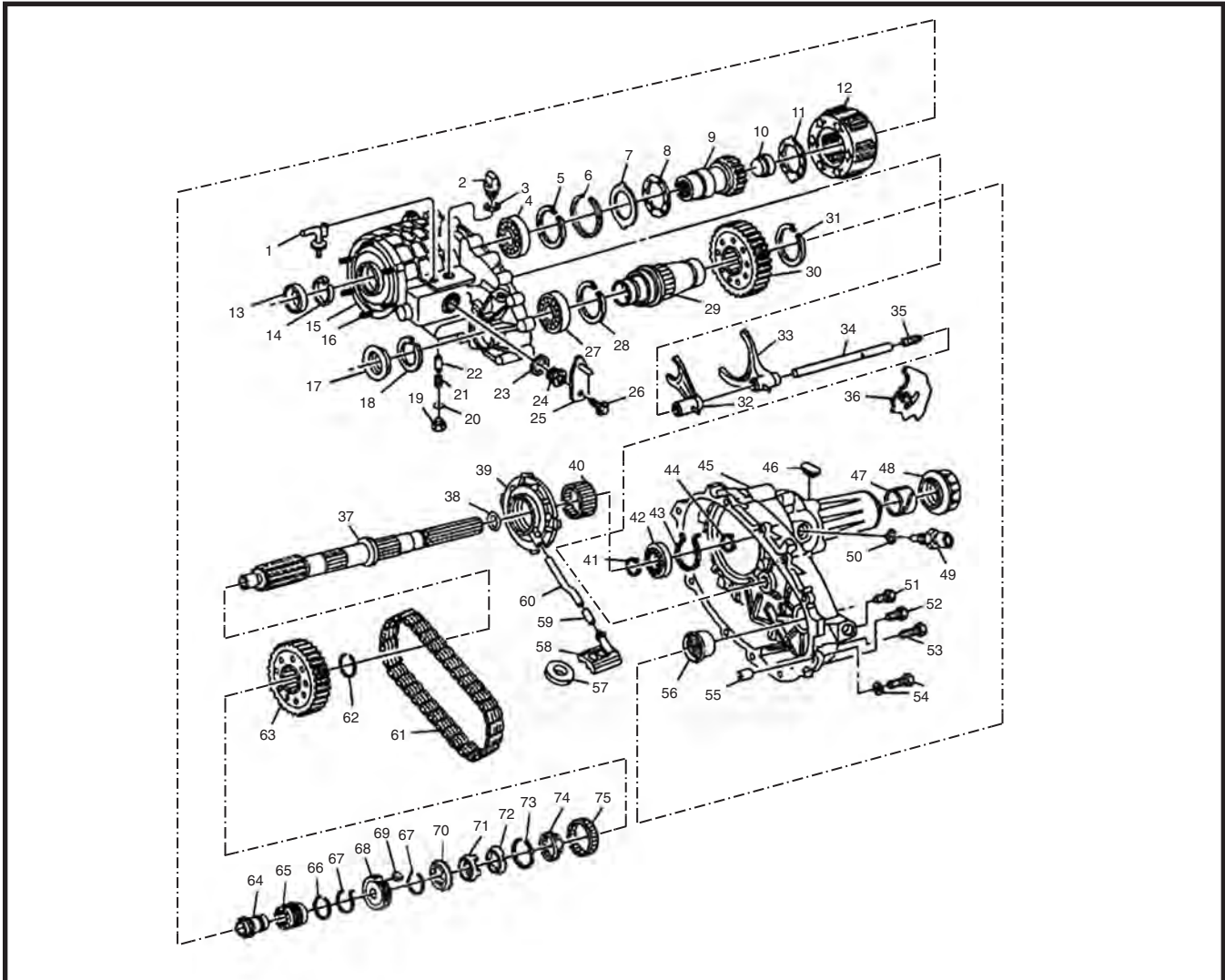

ILL #	MIDWEST #	REF #	REPLACEMENT PART DESCRIPTION
4	110	12547482	INPUT BEARING
5	NV16243	15547397	SNAP RING
6	NV16397	15547396	CARRIER LOCK RING
7	NV16437	15547390	THRUST WASHER
9	NV25890		INPUT WITH 4L60E, 27 SPL.
11	NV16437	15547390	THRUST WASHER (PLASTIC)
12	NV17869	12547997	PLANETARY CARRIER
13	472636	12547466	INPUT SEAL
14	682653		SNAP RING
15	NV30959	12473204	CASE, FRONT LD & HD
17	23740	12474947	OIL SEAL
27	207	12384947	BEARING FRONT OUTPUT
28	89331A	15547377	SNAP RING
29	NV17881	12547448	OUTPUT SHAFT
30	NV31269	12473233	DRIVEN SPROCKET (261)
31	NV22451	12547477	SNAP RING
32	NV17833	125544310	RANGE SHIFT FORK (261)
32	NV29225	12478097	RANGE SHIFT FORK (263) (NON-UPDATED)
33	NV27756	12473219	MODE FORK (C28624)
35	NV16199	15547410	SHIFT FORK SPRING (261)
35	NV29228	12478099	SHIFT FORK SPRING (263)

NV261 / 263 (LD) STYLE (cont.)

ILL #	MIDWEST #	REF #	REPLACEMENT PART DESCRIPTION
36	NV45541		SELECTOR (263 UNIT)
37	NV48714	12384982	MAIN SHAFT
38	471652		OIL PUMP SEAL
39	NV29191	15547423	OIL PUMP
41	NV13955	15547434	SNAP RING (2 REQ.)
42	208L		M/S BEARING
44	96711B	12470554	SNAP RING
45	NV30961	12473226	CASE, REAR
47	WT297-62	15665313	BUSHING
48	NV22507		RR. OUTPUT SEAL
56	HK5020NFC	12547173	BEARING
58	NV16217	15547432	OIL FILTER
60	NV16218		OIL TUBE
61	HV072		CHAIN (1-1/4" WIDE)
63	NV31269	12474614	DRIVE SPROCKET
64	NV27761	12473218	RANGE SHIFT HUB
64	NV41817		RANGE HUB (.368") 263 UNIT
64	NV43681	12384962	RANGER HUB 263 XHD
65	NV45109	12473221	DRIVE SPROCKET HUB
67	NP208K	14071702	SPRING
68/75	NV41061	12477939	SYNCHRONIZER
69	NP208K		SYNCHRO KEYS
70	NV26081	12472963	SYNCHRO RING - OUTER
71	NV21635	12472962	SYNCHRO RING - MIDDLE "FRICTION"
72	NV27722	12472961	SYNCHRO RING - INNER
N.I.	NV26237	12470559	CASE PROTECTOR

KITS

T371R	→ BEARING, SEAL & GASKET KIT
K261HD	→ GASKET & SEAL KIT

NV261/263 (HD) STYLE CHEVROLET® K1500, K2500, K2500HD, K3500, 2000-ON

ILL #	MIDWEST #	REF #	REPLACEMENT PART DESCRIPTION
4	110		INPUT BEARING
5	NV16243	15547397	SNAP RING
6	NV16397	15547396	CARRIER LOCK RING
8/11	NV16437	15547390	THRUST WASHER
9	NV42740		INPUT WITH 4L80E, 32 SPL. - HD
12	NV17869	12547997	PLANETARY CARRIER
13	472636	12547466	INPUT SEAL
14	682653		SNAP RING
15	NV30959	12473204	CASE, FRONT (261)
	NV45544	12384976	CASE, FRONT (263)
17	23740	12474947	FRT. OUTPUT OIL SEAL
27	110	12384947	BEARING, 1/2 TON AND 3/4 TON
28	89331A	15547377	SNAP RING
29	NV25847	12473222	OUTPUT SHAFT
30	NV21965	12473233	DRIVEN SPROCKET
31	NV22451	12547477	SNAP RING
32	NV17833	125544310	RANGE SHIFT FORK (261)
32	NV43682	12384963	RANGE SHIFT FORK (263) WIDE (.368")
32	NV41819		RANGE FORK (263) HD WIDE
33	NV27756	12473219	MODE FORK (C28624)
35	NV16199	15547410	SHIFT FORK SPRING (261)
35	NV29228	12478099	SHIFT FORK SPRING (263)
37	NV48714	12473220	MAIN SHAFT
38	NV13955	15547434	SNAP RING (2 REQ.)
38	471652		OIL PUMP SEAL

NV261 / 263 (HD) STYLE (cont.)

ILL #	MIDWEST #	REF #	REPLACEMENT PART DESCRIPTION
39	NV25904	12478084	OIL PUMP (263)
39	NV29191	15547423	OIL PUMP
42	208L		M/S BEARING
43	96711B	12470554	SNAP RING
45	NV30961	12473226	CASE, REAR
47	WT297-62	15665313	BUSHING
48	NV22507		RR. OUTPUT SEAL
56	HK5020NFC	12547173	BEARING
58	NV16217	15547432	OIL FILTER
60	NV16218		OIL TUBE
61	HV069		CHAIN (1-1/2" WIDE, HD)
63	NV21965		DRIVE SPROCKET
64	NV27761	12473218	RANGE SHIFT HUB (NARROW (.323"))
64	NV41817		RANGE HUB (.368") 263 UNIT
65	NV45109	12473221	DRIVE SPROCKET HUB
67	NP208K	14071702	SPRING
68/75	NV41061	12477939	SYNCHRONIZER
69	NP208K		SYNCHRO KEYS
70	NV26081	12472963	SYNCHRO RING - OUTER
71	NV21635	12472962	SYNCHRO RING - MIDDLE "FRICTION"
72	NV27722	12472961	SYNCHRO RING - INNER
N.I.	NV26237	12470559	CASE PROTECTOR
N.I.	NV37284	12384966	RANGE FORK PADS (UPDATED)

KITS

T371R	→ BEARING, SEAL & GASKET KIT
K261HD	→ GASKET & SEAL KIT

NV261/263 (XHD) STYLE CHEVROLET® K1500, K2500, K2500HD, K3500, 2000-ON

ILL #	MIDWEST #	REF #	REPLACEMENT PART DESCRIPTION
4	110	12547482	INPUT BEARING
5	NV16243	15547397	SNAP RING
6	NV16397	15547396	CARRIER LOCK RING
8/11	NV16437	15547390	THRUST WASHER
9	NV43996	12384974	INPUT WITH ALLISON, 29 SPLINE
12	NV17869	12547997	PLANETARY CARRIER
13	472636	12547466	INPUT SEAL
14	682653		SNAP RING
15	NV21943	12478078	CASE, FRONT (261)
15	NV45545		CASE, FRONT (263)
17	23740	12474947	FRT. OUTPUT OIL SEAL
27	110	12384947	BEARING, FRONT OUTPUT
28	89331A	15547377	SNAP RING
29	NV25847	12473222	OUTPUT SHAFT
30	NV40910	12478083	DRIVEN SPROCKET (263)
31	NV22451	12547477	SNAP RING
32	NV17833	125544310	RANGE SHIFT FORK (261)
32	NV43682	12384963	RANGE FORK 263 XHD w/ SPRING - w/o SPRING USE NV41819
33	NV27756	12473219	MODE FORK (C28624)
35	NV16199	15547410	SHIFT FORK SPRING (261)
35	NV29228	12478099	SHIFT FORK SPRING (263)

NV261 / 263 (XHD) STYLE (cont.)

ILL #	MIDWEST #	REF #	REPLACEMENT PART DESCRIPTION
37	NV47936	12478082	MAIN SHAFT
38	471652		OIL PUMP SEAL
38	NV13955	15547434	SNAP RING (2 REQ.)
39	NV25904	12478084	OIL PUMP
42	NV26324	12478090	M/S BEARING
43	96711B	12470554	SNAP RING
45	NV25900	12478092	CASE, REAR
47	NV18172	15665313	BUSHING
48	4741		RR. OUTPUT SEAL
56	HK5020NFC	12547173	BEARING
58	NV16217	15547432	OIL FILTER
60	NV35212	12478087	OIL TUBE
61	HV074		CHAIN (1-1/2" WIDE)
63	NV40910	12478083	DRIVE SPROCKET
63A	NV45109		DRIVE SPROCKET, HUB (LATE)
	NV27721R		DRIVE SPROCKET, HUB (EARLY)
64	NV43681	12384962	RANGER HUB 263 XHD
65	NV45109	12473221	DRIVE SPROCKET HUB
67	NP208K	14071702	SPRING
68/75	NV41061	12477939	SYNCHRONIZER
69	NP208K		SYNCHRO KEYS
70	NV26081	12472963	SYNCHRO RING - OUTER
71	NV21635	12472962	SYNCHRO RING - MIDDLE "FRICTION"
72	NV27722	12472961	SYNCHRO RING - INNER
N.I.	NV26237	12470559	CASE PROTECTOR

KITS

T371RA	→ BEARING, SEAL & GASKET KIT
K261XHD	→ GASKET & SEAL KIT

Performance & 4x4 Differential Components

MotiveGear
Performance

Motive
Gear

Performance & 4x4
Differential Components

- OE Quality Replacement Parts
- Backed by Warranty
- Three Distribution Locations
Means Quick Delivery



We supply a full line of differential components for light duty, performance & off road vehicles.

BW1350 STYLE

FORD® BRONCO II, EXPLORER, RANGER

1983-97 (MECHANICAL), 1986-97 (ELECTRICAL)

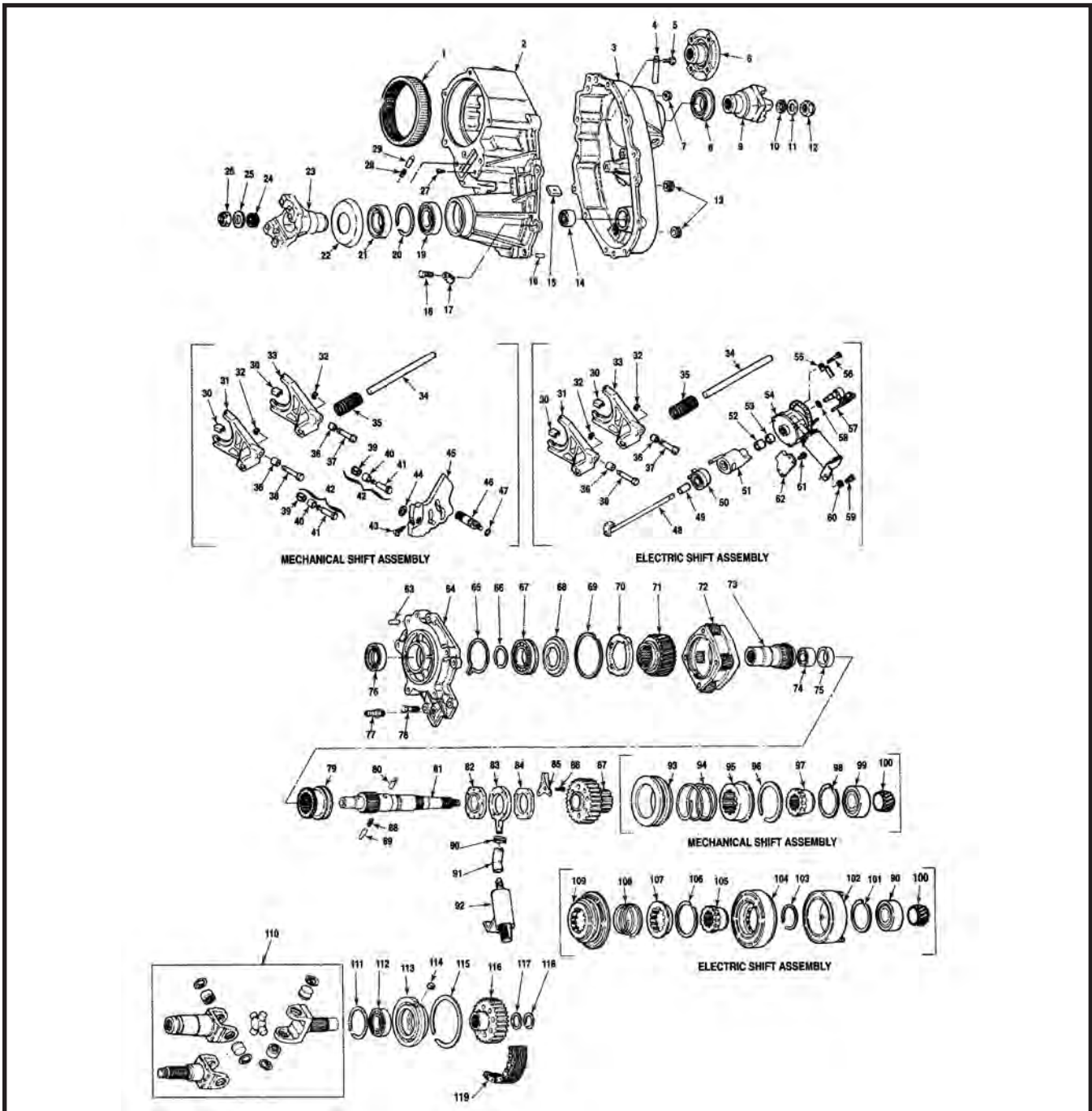

ILL #	MIDWEST #	REF #	REPLACEMENT PART DESCRIPTION
1	1350162001		RING GEAR
2	1350565003		FRONT CASE HALF ASSY - (MECH. SHIFT)
2	1350565004		FRONT CASE HALF ASSY - (ELEC. SHIFT)
3	1350539003		REAR CASE HALF ASSY - (MECH. SHIFT)
3	1350539005		REAR CASE HALF ASSY - (ELEC. SHIFT)
5	1300183018		BOLT, CASE HALVES (9 REQ.)
6	1300031001		COMPANION FLANGE, REAR OUTPUT
7	1300149002		NUT

BW1350 STYLE (cont.)

ILL #	MIDWEST #	REF #	REPLACEMENT PART DESCRIPTION
8	1000044052		SEAL, REAR OUTPUT
9	1000031022		YOKE, REAR OUTPUT
10	1000044012		SEAL
11	1000047016		WASHER
12	1900149001		NUT
13	445751		PLUG (2 REQ.)
14	1000132039		NEEDLE BEARING
15	1000012002		MAGNET
16	141281		DOWEL PIN
17	1000056007		CUP, WIRING HARNESS
19	108		BEARING, FRONT OUTPUT
20	4766B		SNAP RING
21	1000044051		SEAL, FRONT OUTPUT
22	1350035002		DEFLECTOR
23	1300031004		YOKE, FRONT OUTPUT
23	1000531011		YOKE ASSY
27	1350183002		SCREW
28	1350156003		SPRING
29	1350108001		POPPET
30	1345235001		FORK PADS
31	1350096004		SHIFT FORK - RANGE
31	1350596005		SHIFT FORK ASSY
32	1345056003		CRESCENT RING
33	1350096003		SHIFT FORK - MODE
33	1350596003		SHIFT FORK ASSY MODE
33	1354096001		SHIFT FORK ASSY - UPDATED MODE
34	1350100001		RAIL
35	1350156002		SPRING, RETURN
36	1352127001		ROLLER , CAM
37	1300043006		PIN, MODE FORK
39	1350040002		RETAINER - OPTIONAL
40	1352127001		ROLLER, CAM - OPTIONAL
41	1350043001		PIN - OPTIONAL
43	1350183002		SET SCREW
44	1345056002		SNAP RING
45	1350099006		SHIFT CAM
46	1350122001		SHIFT SHAFT
47	T89B-108		O-RING
48	1350122004		SHIFT SHAFT (ELEC. SHIFT)
49	1350053002		SPACER
50	1350156006		TORSION SPRING
51	1350099007		SHIFT CAM
52	1300127002		BEARING
53	1300044001		OIL SEAL
54	1354410003		SHIFT MOTOR ASSY - 7 PRONG
55	1350056002		BRACKET
56	0011503949		BOLT
57	1350140002		SPEED SENSOR
58	1000141014		O-RING
59	0011500420		BOLT
60	011503961		WASHER
61	009411592		BOLT
62	1350056003		BRACKET
63	1000043017		PIN
64	1350672001		ADAPTER ASSY - FRONT
65	1000139039		SNAP RING
66	1000139040		RETAINING RING
67	1000130011		BEARING, INPUT

BW1350 STYLE (cont.)

ILL #	MIDWEST #	REF #	REPLACEMENT PART DESCRIPTION
68	1350193001		THRUST WASHER
69	1000139043		RETAINING RING
70	1350014001		THRUST PLATE
71	1350165001		SUN GEAR
72	1350659008		PLANETARY ASSY
73	1350689001		INPUT SHAFT ASSY
74	4840G		NEEDLE BEARING
75	1345127002		BEARING SLEEVE
76	710062	1000044054	SEAL, INPUT
77	1345072001		BARB, BREATHER
78	1300183018		BOLT
79	1350089001		REDUCTION HUB
80/89	1345043007		PUMP PIN (2 REQ.)
81	1354171003		OUTPUT SHAFT - REAR
82	1345039007		COVER, PUMP FRONT
83	1345097004		PUMP HOUSING
84	1345039005		COVER, PUMP, REAR
85	1350056004		RETAINER, PUMP
86	1345183003		BOLT, PUMP (4 REQ.)
87	1350144003		DRIVEN SPROCKET
88	1345156004		SPRING - PUMP PIN
90	1345056005		HOSE CLAMP
91	1356034001		PUMP TUBE
92	1345238001		FILTER, PUMP
93	1350055002		COLLAR, LOCKUP - (MECH. SHIFT)
94	1350156001		RETURN SPRING - (MECH. SHIFT)
95	1350089003		HUB, LOCKUP - (MECH. SHIFT)
96	1000139041		SNAP RING - (MECH. SHIFT)
97	1350090001		HUB, SHIFT COLLAR - (MECH. SHIFT)
98/101	R6A-7.5		SNAP RING
99	1000130008		BEARING
100	1350110003		SPEEDO GEAR
102	1350640004		CLUTCH COIL ASSY
103	1000139029		SNAP RING
104	1350212001		HOUSING, CLUTCH - (ELEC. SHIFT)
105	1350090002		HUB - SHIFT COLLAR - (ELEC. SHIFT)
106	1000139041		SNAP RING - (ELEC. SHIFT)
107	1356089002		HUB, LOCKUP - (ELEC. SHIFT)
109	4400055001		COLLAR, LOCKUP - (ELEC. SHIFT)
110	1350671004		JOINT ASSY - FRONT YOKE
110	1350671003		JOINT ASSY
111	RGA-7.5		SNAP RING
112	1000130008		BEARING
113	1350107001		RETAINER, BEARING
114	1000056008		RETAINING CLIP
115	1000139043		SNAP RING
116	1350144004		DRIVE SPROCKET
117	1350193003		SPACER
118	1000139038		SNAP RING
119	HV022	1350143001	CHAIN - 1-1/4" WIDE - CAN USE 10-022C

KITS

T1350R	→	BEARING, SEAL & GASKET KIT
SP1350-50	→	SMALL PARTS KIT
K1350	→	GASKET & SEAL KIT

BW1345 STYLE

FORD® BRONCO, F150/350 1980-91

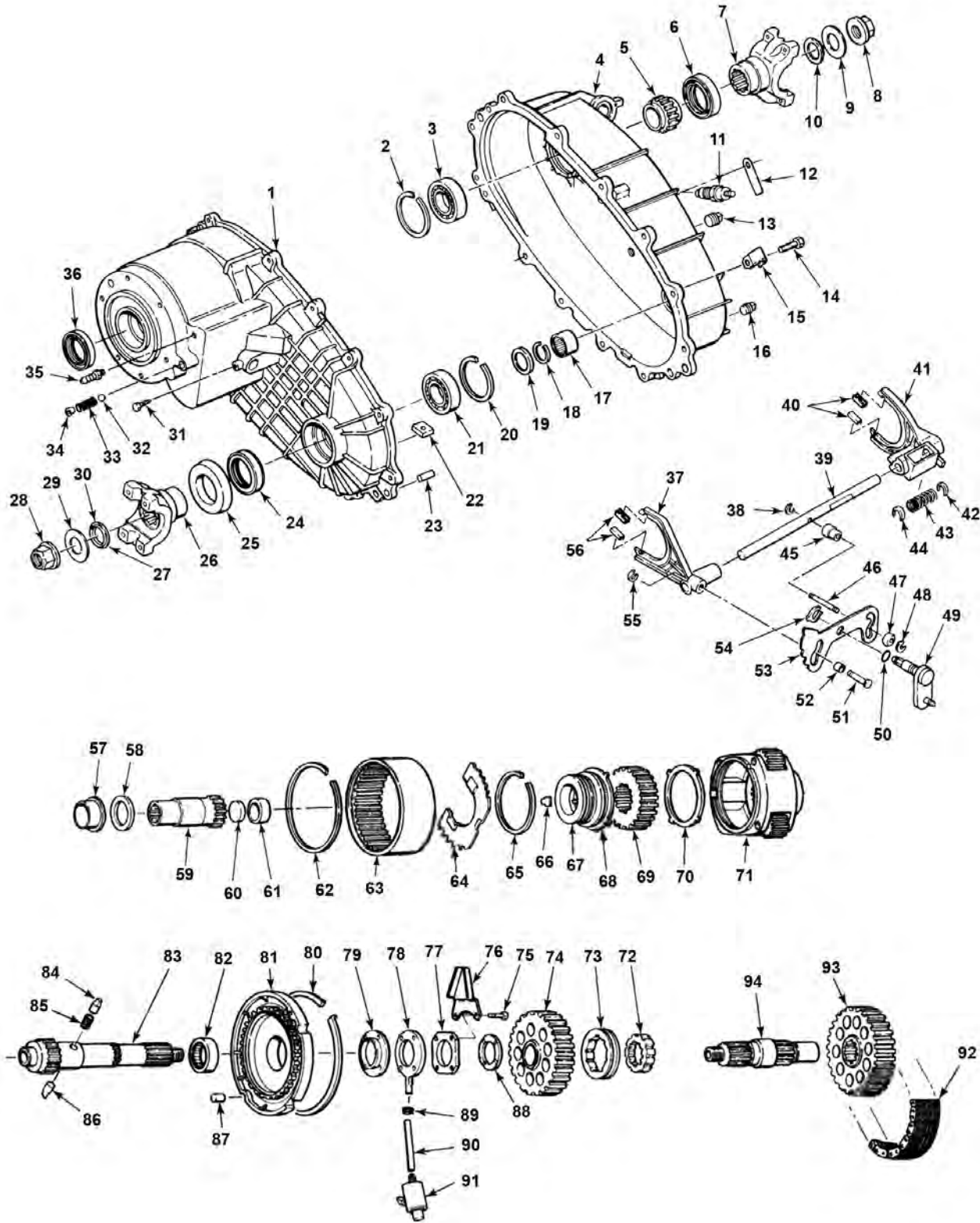

BW1345 STYLE (cont.)

ILL #	MIDWEST #	REF #	REPLACEMENT PART DESCRIPTION
1	1345565002	E0TZ7005M	FRONT CASE HALF ASSY
2	T86-7.5		SNAP RING
3	207	1345130001	BEARING, REAR OUTPUT
4	1345539010	E3TZ7005H	REAR CASE HALF ASSY
5	1345110006	E1TZ17285A	SPEEDO GEAR, 8T YELLOW - CALL FOR MORE APPLICATIONS
6	1000044053	E5TZ7B215A	OIL SEAL, REAR OUTPUT
7	1345031001	E0TZ7B214C	YOKE, REAR - AFTER 1/89
7	1345031003	E1TZ7B214A	YOKE, REAR - BEFORE 1/89
8	1000149019	1900149002	NUT, REAR YOKE
9	1000047015		WASHER, REAR YOKE
10	1000044045		OIL SEAL, REAR YOKE (2 REQ.)
11	1345140001	E0TZ7E440B	SWITCH, 4WD - BEFORE 1/87
11	1300140003		SWITCH, 4WD - AFTER 1/87
12			I-D TAG
14	1900183010		BOLT
15	1000056007		WIRE CLIP
16/13	444576		PLUG
17	SCE2012	E0TZ7127C	NEEDLE BEARING
18	1345139004	E0TZ7917D	SNAP RING
19	1345193005	E0TZ7119C	WASHER
20	T86-7.5	E0TZ7917F	SNAP RING
21	207	1345130001	BEARING, FRONT OUTPUT
22	1000012002	E3TZ7E290A	MAGNET
23	141281		DOWEL PIN (2 REQ.)
24	3946	1900044012	OIL SEAL, FRONT OUTPUT
25	1345035001		SLINGER, FRONT YOKE
26	1345031002	E1TZ7B214C	YOKE, FRONT OUTPUT, PICKUP
26	1345031003	E1TZ7B214A	YOKE, FRONT OUTPUT, BRONCO
27	1000044045	E3TZ7A294A	SEAL, FRONT YOKE SPLINE
28	1000149019	1900149002 / E0TZ7045B	NUT, FRONT YOKE
29	1000047015		WASHER, FRONT YOKE
31	1345183001	E0TZ7D167A	SET SCREW - 1/4 - 20 X 1/2 HEX HEAD
32	453593		BALL, DETENT - 3/8 STEEL
33	1345156001		SPRING, DETENT
34	4572D		CAP PLUG
35	1345072001		BREATHER BARB
36	1345044054		OIL SEAL, INPUT (2 REQ.)
37	1345096005	E0TZ7289A	FORK, RANGE SHIFT
38	1345056001		CRESCENT RING
39	1345100002	DOTZ7240B	SHIFT RAIL
40	1345235001	E0TZ7C430A	FORK PADS/MODE FORK (2 REQ.)
41	1345096004	E0TZ7289C	FORK, MODE SHIFT
42/44	1345040001	F0TZ7E219A	SPRING RETAINER (2 REQ.)
43	1345156006	E0TZ7219B	SPRING - LOCK UP FORK
45	1345127003	F0TZ7B416A	CAM ROLLER
46	1345043006	E0TZ7B051B	PIN
47	1345127004	E0TZ7233A	CAM ROLLER
48	1345056001		CRESCENT RING
49	1345598006	E3TZ7B106B	LEVER ASSY
50	T89B-108		SEAL
51	1345043001	E0TZ7235A	PIN
52	1345127005	E0TZ7335B	CAM ROLLER
53	1345099004	E0TZ7F063B	SHIFT CAM
54	1345056002	15580259	CLIP RING
55	1345056003		RETAINING CUP
56	1345235001		FORK PADS/RANGE FORK (2 REQ.)
57	1345127001	E0TZ7110B	INPUT SHAFT BUSHING
58	1345193001	E0TZ7A385C	THRUST WASHER

BW1345 STYLE (cont.)

ILL #	MIDWEST #	REF #	REPLACEMENT PART DESCRIPTION
59	1345689003	E0TZ7017D	INPUT SHAFT ASSY 6.13"
60	9421756		PLUG
61	1345127002	E0TZ7065C	BUSHING
62	1345139002	E0TZ7C122A	SNAP RING
63	1345162002	E0TZ7A153B	RING GEAR
64	1345014003	E0TZ7B066B	RING GEAR PLATE
65	1345139001	E0TZ7C122B	SNAP RING
66	1345104001	E0TZ7B220A	KEY - PINION CAGE
67	1345103002	E0TZ7100C	SHIFT HUB , RANGE
69	1345165002	E0TZ7D063A	SUN GEAR
70/68	1345193003	E0TZ7D484C	THRUST WASHER (SUN GEAR) - (2 REQ.)
71	1345659004	E0TZ7A398B	PLANETARY ASSY
72	1345090001	E0TZ7917F	SHIFT HUB (MODE)
73	1345055001	E0TZ7106A	SHIFT COLLAR (MODE)
74	1345144005	E0TZ7177C	DRIVE SPROCKET 1-1/4" WIDE - 34T
74	1345144001	E0TZ7177D	DRIVE SPROCKET 1-1/2" WIDE - 36T
75	1345183003	E0TZ7A291A	SCREW, PUMP - M5 X 0.8 X 20.0 HEX HEAD
76	1315056007	E6TZ7E215A	PUMP RETAINER
77	1345039005	E0TZ7A152A	REAR PUMP COVER
78	1345097004	E0TZ7A149B	PUMP BODY
79	1345039007	E0TZ7A152B	FRONT PUMP COVER
80	1345139006	E0TZ7917E	SNAP RING
81	1345607006		RETAINER PLATE AND BEARING ASSY
82	1000132015	E0TZ7A132A	NEEDLE BEARING - CAN USE B2812
83	1345171003	E0TZ7061D	MAIN SHAFT/REAR OUTPUT (UPPER)
85	1345156004	E0TZ7A205A	SPRING - PUMP PIN
86/84	1345043007	E0TZ7A250A	PUMP PIN (2 REQ.)
87	1411275	E6TZ7262A	DOWEL PIN (2 REQ.)
88	1345193004	E0TZ7A385C	THRUST WASHER
89	1345056005	15580273	HOSE CLAMP (2 REQ.)
90	1345034003	E0TZ7A210A	HOSE 1.134"
91	1345238001	E0TZ7A098A	FILTER
92	13797	E2TZ7A029A	CHAIN 1-1/4 WIDE (ALT 13797) - CAN USE HV012
92	HV013	1345143001	CHAIN 1-1/2 WIDE
93	1345144004	E2TZ7177B	DRIVEN SPROCKET 1-1/4" WIDE - 34T
93	1345144002	E0TZ7177E	DRIVEN SPROCKET 1-1/2" WIDE - 36T
94	1345171002	E0TZ7061E	OUTPUT SHAFT - FRONT

KITS

T1345R	→ BEARING KIT (INCLUDES BEARING, SEALS & GASKET)
K1345	→ GASKET & SEAL KIT
SP1345-50	→ SMALL PARTS KIT
1345410001	→ HOSE KIT
1345410002	→ PUMP KIT

Motive Gear®

BW1354 STYLE

FORD® BRONCO II, RANGER, EXPLORER 1983-97

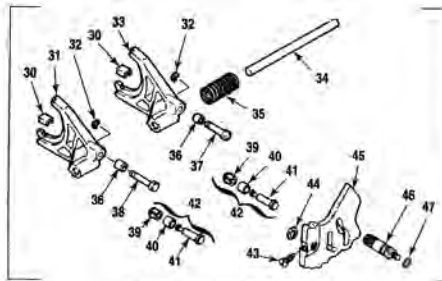
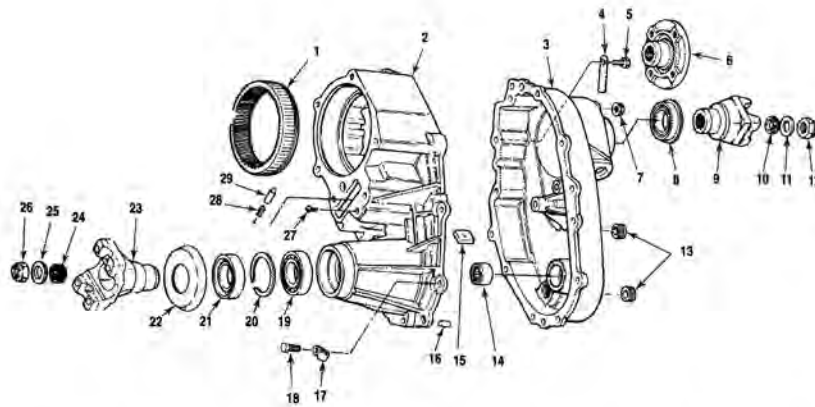

MECHANICAL SHIFT ASSEMBLY

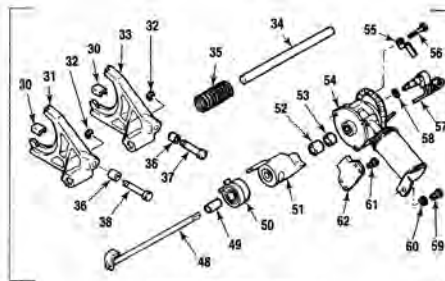

ELECTRIC SHIFT ASSEMBLY

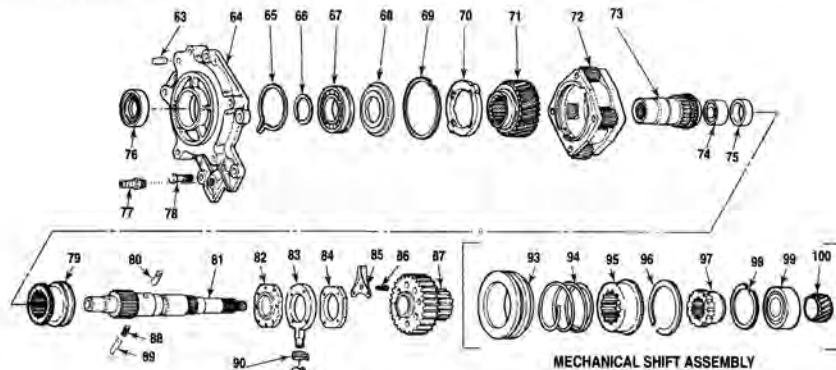

MECHANICAL SHIFT ASSEMBLY

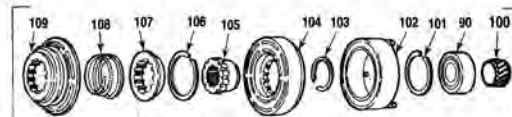

ELECTRIC SHIFT ASSEMBLY

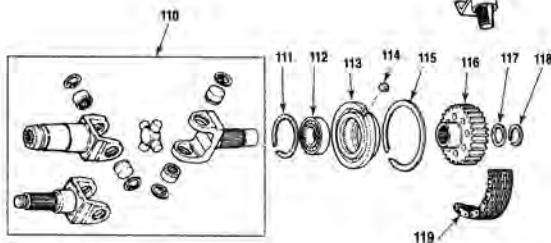

ILL #	MIDWEST #	REF #	REPLACEMENT PART DESCRIPTION
1	1350162001	E3T27A153A	RING GEAR
2	1354065001		FRONT CASE HALF - (MECH.)
2	1354065002		FRONT CASE HALF - (ELEC.)
2	1354565001	F0T27005D	FRONT CASE HALF ASSY - (MECH.)
2	1354565002		FRONT CASE HALF ASSY - (ELEC.)
3	1354039002		REAR CASE HALF - (ELEC.)

BW1354 STYLE (cont.)

ILL #	MIDWEST #	REF #	REPLACEMENT PART DESCRIPTION
3	1354039001		REAR CASE HALF - (MECH.)
3A	1354539002	F0TZ7005C	REAL CASE HALF ASSY - (ELEC.)
3A	1354539001	F0TZ7005B	REAR CASE HALF ASSY - (MECH.)
4	1354199-XXX		I.D. TAG
6	1300031001	E5TZ7B214A	COMPANION FLANGE
8	1900044009		OIL SEAL
10	1000044012	E3TZ7025B	SEAL (2 REQ.)
11	1000047016		WASHER (2 REQ.)
12	1900149001	E3TZ7045C	NUT - OUTPUT FLANGE (2 REQ.)
14	SCH1310	1900132001	NEEDLE BEARING, FRONT OUTPUT
15	1000012002	E3TZ73290A	MAGNET
16	141281		DOWEL PIN
19	206		FRONT OUTPUT BEARING
20	SELECT FIT		SNAP RING
21	1900044009		OIL SEAL
22	1350035002		SLINGER
23	1300031005		YOKE
23A	1000531005		YOKE ASSY - FRONT OUTPUT
24	1000044012	E3TZ7052B	SEAL
25	1000047016		WASHER
26	1900149001	E3TZ7045C	NUT
28	1350156003	E3TZ7219A	SPRING
29	1350108001		POPPET
30	1345235001	E0TZ7C430A	FORK PADS
31	1350096004	E6TZ7289A	RANGE SHIFT FORK
31	1354096001	F2TZ7289A	SHIFT FORK, RANGE LATE, ALL EXCEPT 1354-004, 005, 014
33	1354096003		MODE FORK
34	1350100001	E3TZ7240E	SHIFT RAIL
35	4400156001	F1TZ7219A	RETURN SPRING
37/38	1000043017		ROLL PIN
39	1350156005	E5TZ7C349A	ASSIST SPRING
40	1352127001	E6TZ7335A	ROLLER
41	1300127001	E5TZ7C191A	ROLLER
42	1350543001	E9TZ7235A	PIN & ROLLER
43	1350183002	E3TZ7A443H	SCREW
44	1345056002	15580259	CLIP RING
45	1350099006	E6TZ7F063A	SHIFT CAM
45	1350099007	E6TZ7F063B	CAM, (ELEC. SHIFT)
46	1354122003		SHIFT SHAFT
47	T89B-108		O-RING
48	1350122002		SHIFT SHAFT
49	1350053002		SPACER
50	1350156008		TORSION SPRING
N.I.	1300140003		4WD INDICATOR SWITCH
52	1300127002		BEARING - SHIFT SHAFT
53	1300044001	E6TZ7B216A	SEAL - (ELEC. SHIFT)
54	1354410003		SHIFT MOTOR ASSY - 10 -PRONG CONNECTOR
54	1354648010		MOTOR w/ 7 -PRONG CONNECTOR - 1995 & UP
55	1354056004		BRACKET - SHIFT MOTOR HARNESS
57A	1350640003	E6TZ7F293A	SENSOR ASSY - INCLUDES SWITCH AND O'RING
57	1350140002		SPEED SENSOR SWITCH
58	1000141014		O-RING
59	0011500420		BOLT - SHIFT MOTOR
60	011503961		WASHER - FLAT
61	1900183010		BOLT
62	1000056007		CLIP - WIRING HARNESS
64	1354672001		FRONT ADAPTER ASSY - ALL
65	1000139039	E3TZ7917C	SNAP RING
66	1000139040	E3TZ7917D	RETAINING RING
67	109L		INPUT BEARING
69	1000139043	E3TZ7C122A	SNAP RING
70	1350014001	E3TZ7B066A	THRUST PLATE
71	1350165001	E3TZ70063A	SUN GEAR
72	1350659001		PLANET CARRIER
72	1350659008	E6TZ7A398A	PLANETARY ASSY
73	1354189001	F0TZ7017C	INPUT SHAFT

BW1354 STYLE (cont.)

ILL #	MIDWEST #	REF #	REPLACEMENT PART DESCRIPTION
74	SCE2012		POCKET BEARING
75	1345127002	E0TZ7065C	BEARING SLEEVE
76	206	E3TZ7025A	BEARING, REAR OUTPUT
77	1345072001	15580319	BREATHER BARB
78	1900183010		BOLT
79	1350089001	E3TZ7100E	RANGE HUB - FITS 004, 005, 014
79	1350089002		RANGE HUB - FITS ALL OTHERS
80/89	1345043007	E0TZ7A250A	PUMP PIN (2 REQ.)
81	1354171003		MAIN SHAFT - 1354-004, 005, 014
81	1354171001		MAIN SHAFT - 1354-021
81	1354171004		MAIN SHAFT - (EXC. ABOVE)
81A	1350671001		MAIN SHAFT AND PUMP ASSY
81A	1354671005		MAIN SHAFT AND PUMP ASSY
82	1345039007	E0TZ7A152B	FRONT COVER - PUMP
83	1345097004	E0TZ7A149B	MAIN BODY - PUMP
84	1345039005	E0TZ7A152A	REAR COVER - PUMP
85	1350056004	E3TZ7E215C	RETAINER - PUMP
N.I.	1350193001	E3TZ7A385B	THRUST WASHER
86	1345183003	E0TZ7A291A	BOLT - PUMP
87	1350144003	F2TZ7177B	CHAIN SPROCKET - DRIVE - EXC. 1354-014
88	1345156004	E0TZ7A205A	SPRING - PUMP
90	1345056005	15580273	HOSE CLAMP
91	1356034001		HOSE
92	1345238001	E0TZ7A098A	FILTER
93	1350055002	E3TZ7106B	COLLAR, MODE SHIFT - (MECH.)
94	1350156001	E3TZ7D126B	RETURN SPRING - (MECH.)
95	1350089003	E3TZ089003	HUB - MODE SHIFT - (MECH.)
96	1000139041	E3TZ7917E	SNAP RING
97	1350090001	E3TZ7100D	HUB, SHIFT COLLAR - (MECH.)
N.I.	1350589003		LOCK-UP ASSEMBLY
100	1350110002	F0TZ17285A	SPEEDO DRIVE GEAR
101	RGA-7-5	E3TZ7917A	SNAP RING (2 REQ.)
102	1350640004	1900645001	CLUTCH COIL ASSY
103	1000139029		RETAINING RING
104	1354212001	F1TZ76362A	CLUTCH HOUSING, (ELEC. SHIFT)
105	1350090002	E6TZ7100A	HUB, SHIFT COLLAR - (ELEC.)
107	1900089001	1356089002	HUB - MODE SHIFT - (ELEC.)
108	1350156007	E6TZ7D126A	RETURN SPRING - (ELEC.)
109	4400055001	F1TZ7106B	COLLAR, MODE SHIFT - (ELEC.)
115	1000139038	E3TZ7917B	SNAP RING
116	1354144004	E3TZ7177A	CHAIN SPROCKET - DRIVEN
117	1350193003	E3TZ7119J	SPACER
119	HV022	1350143001	CHAIN
N.I.	1900044009		SEAL

KITS

T1354R	→ BEARING GASKET & SEAL KIT
K1354	→ GASKET & SEAL KIT

Motive Gear®

BW1356 STYLE

F150/350, 1987-96

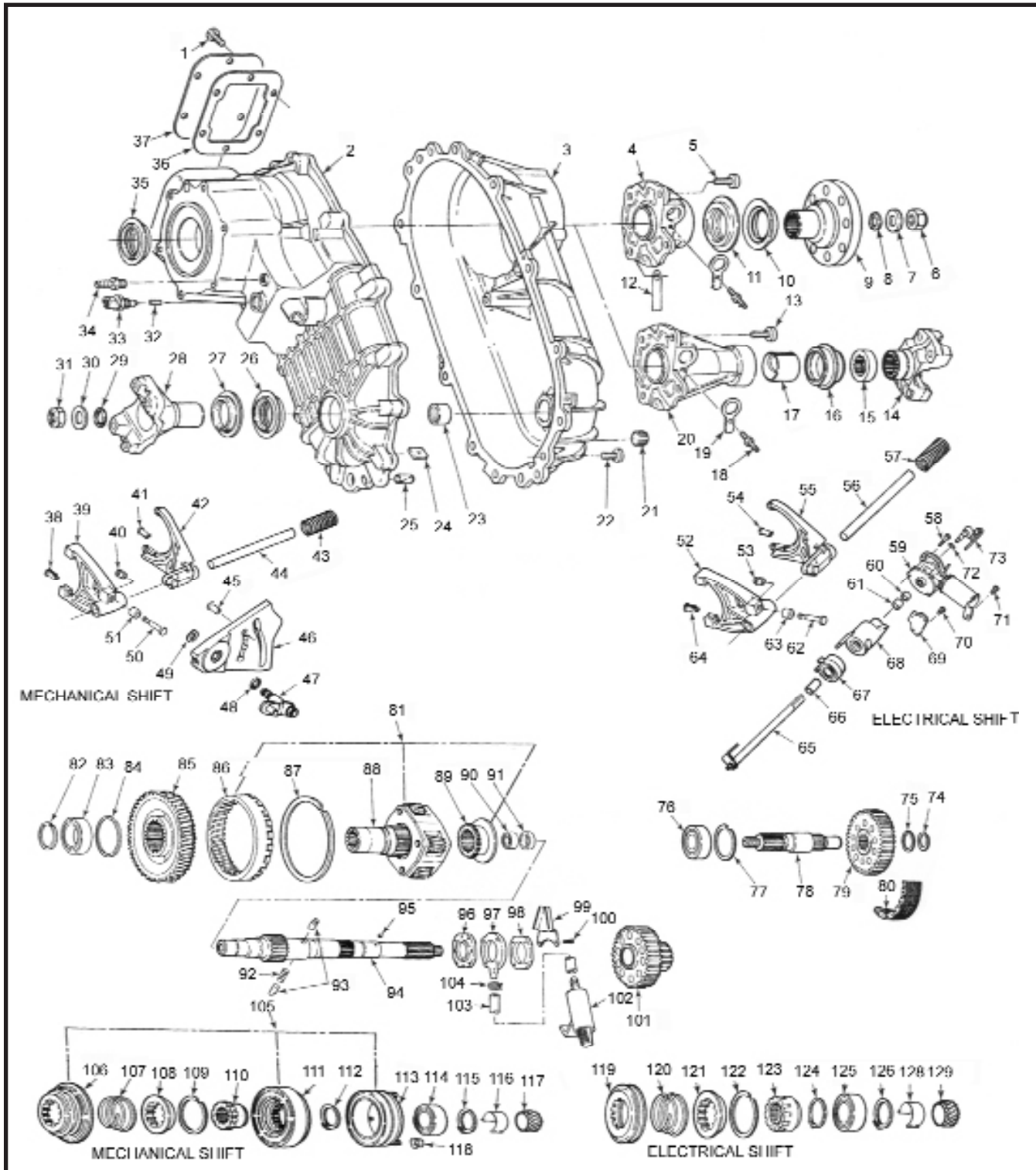

BW1356 STYLE (cont.)

ILL #	MIDWEST #	REF #	REPLACEMENT PART DESCRIPTION
1	1000183041		BOLT - PTO COVER
2	1356565011		FRONT CASE HALF (MECH. SHIFT - PTO)
2	1356565005		FRONT CASE HALF (MECH. SHIFT w/o PTO)
2	1356565006		FRONT CASE HALF (ELEC. SHIFT)
3	1356539003		REAR CASE HALF (MECH. SHIFT)
3	1356539004		REAR CASE HALF (ELEC. SHIFT)
4	1356566003		BEARING CAP ASSY
5	1300183017		BOLT - WASHER
6	1900149002		NUT - REAR OUTPUT SHAFT
7	1000047015		WASHER (REAR YOKE/FLANGE)
8	1300016002		OIL SEAL - REAR YOKE/FLANGE (BOLT-ON)
9	1356531004		REAR FLANGE
10	1345035001		DEFLECTOR - SLINGER
11	1900044012		SEAL - REAR FLANGE (BOLT-ON)
13	1360183008		BOLT - 1987-88 (4 REQ.)
13	1300183017		BOLT/WASHER - 1989 & LATER
14	1356531002		REAR YOKE
15	1356016001		OIL SEAL - SLIP YOKE SPLINE
16	1900044013		REAR SEAL - SLIP YOKE
17	1356127001		BUSHING - REAR SLIP YOKE
18	1300146003		STUD
19	1356614002		SPEEDO PLATE
20	1356566012		TAIL HOUSING ASSY
21	1300052003		PLUG
22	1300183008		BOLT 1987-88 (12 REQ.)
22	1300183017		BOLT/WASHER - 1989-ON (12 REQ.)
23	SCE2012		NEEDLE BEARING
24	1000012002		MAGNET
25	1300043005		DOWEL PIN
26	1900044012		SEAL - FRONT OUTPUT
27	1300035001		SLINGER
28	1356531001		YOKE ASSY
29	1000016002		OIL SEAL
30	1000047015		WASHER
31	1900149002		NUT - FRONT OUTPUT SHAFT
32	1300183019		SET SCREW
33	1300140007		SWITCH - 4WD INDICATOR
34	1300072001		BARB - BREATHER
35	1900044012		SEAL - INPUT
36	PTO-55		GASKET - PTO COVER
37	1300191010		COVER - PTO
38/64	1356235001		SHIFT FORK PADS (RANGE FORK) - (2 REQ.)
39/52	4400596001R		SHIFT FORK ASSY (RANGE)
40	1350040002		RETAINER - ALSO SERVICED IN #39
41/54	1345235001		SHIFT FORK PADS (MODE FORK) - (2 REQ.)
42/55	1356096007		SHIFT FORK - NEW STYLE ALL PLASTIC
43/57	1350156002		RETURN SPRING
44/56	1350100001		SHIFT RAIL
45	1356127008		BUSHING - SHIFT CAM
46	1356599001		SHIFT CAM - LATE STYLE SPLINED
47	1356598008		SHIFT LEVER - CURVED - NO SHAFT
47	1356598009		SHIFT LEVER - STRAIGHT - SPLINED SHAFT
47	1356598007		SHIFT LEVER - STRAIGHT - SET SCREW SHAFT
47	1356598006		SHIFT LEVER - STRAIGHT w/o SHAFT
47	1356122001		SHIFT SHAFT ONLY
48	1300016001		OIL SEAL

BW1356 STYLE (cont.)

ILL #	MIDWEST #	REF #	REPLACEMENT PART DESCRIPTION
49	1345056002		RETAINING CLIP
50/62	1350043001		RETAINER PIN - ALSO SERVICED IN #39
51/63	1352127001		CAM ROLLER
58	0011503949		BOLT - SHIFT MOTOR
59	1356640003		SHIFT MOTOR
60	1300044001		OIL SEAL - SHIFT SHAFT - (ELEC. SHIFT)
61	1300127002		SLEEVE BEARING
65	1356122007		SHIFT SHAFT - (ELEC. SHIFT)
66	1356053005		SPACER - SHIFT SHAFT
67	1356156006		SPRING - TORSIONAL
68	1356099007		CAM - (ELEC. SHIFT)
69	1356056003		BRACKET WIRING HARNESS
70	11505117		BOLT - WIRING BRACKET
71	11505117		BOLT - SHIFT MOTOR
72	1000141014		O-RING
73	1350140002		SENSOR - SPEED
74	1300139010		SNAP RING
75	1345193005		WASHER
76	1345130001		BALL BEARING - FRONT OUTPUT
77	T86-7.5		SNAP RING
78	1356171008		SHAFT - FRONT OUTPUT
79	1356144002		SPROCKET - DRIVEN
80	13797	HV012	DRIVE CHAIN
81	1356410003		PLANETARY UPDATE KIT - NON-PTO - CAN USE 1356410004
81	1356410004		PLANETARY UPDATE KIT - PTO
82	1300139009		RETAINING RING - INPUT BEARING
83	1300130001		BEARING - INPUT SHAFT
84	1300139010		RETAINING RING - PTO DRIVE GEAR
85	1356070002		GEAR - PTO DRIVE
86	1356162002		RING GEAR - BEFORE 6/5/95 - USE 1356410003/1356410004
87	1300139012		RETAINING RING - PLANETARY RING
88	1356659009		PLANETARY ASSY - INPUT NON-PTO - AFTER 6/5/95
88	1356659010		PLANETARY ASSY - INPUT - PTO - AFTER 6/5/95
88	1356659007		PLANETARY ASSY - BEFORE 6/5/95 - USE 1356410003 NON-PTO
88	1356659008		PLANETARY ASSY - BEFORE 6/5/95 - USE 1356410004 - PTO
89	1356089001R		RANGE SHIFT HUB - EARLY BEFORE 6/5/96
89	1356089003R		RANGE SHIFT HUB - LATE AFTER 6/5/96
90	1300132012		NEEDLE BEARING
91	1345127002		BUSHING - INPUT PILOT
92	1345156004		PUMP PIN SPRING
93	1345043007		PUMP KIT (2 REQ.)
94	1356171007R		MAIN SHAFT - REAR SLIP YOKE
94	1356171009		MAIN SHAFT - REAR BOLT ON YOKE
94	1356171013		MAIN SHAFT - REAR BOLT ON FLANGE
95	1000109001		BALL - SPEEDO GEAR
96	1345039007		PUMP COVER - FRONT
97	1345097004R		PUMP HOUSING
98	1345039005		PUMP COVER, REAR
99	1356056004		PUMP RETAINER
100	1345183003		BOLT - PUMP ASSY
101	1356144003		SPROCKET - DRIVE
102	1345238001		OIL STRAINER
103	1356034001		HOSE
104	1345056005		CLAMP - PUMP HOSE
106	1356055003		COLLAR - LOCK UP (ELEC. SHIFT)

BW1356 STYLE (cont.)

ILL #	MIDWEST #	REF #	REPLACEMENT PART DESCRIPTION
107	1350156007		SPRING SLEEVE RETURN
108	1356089002		HUB REDUCTION 9 SPLINE
109	1000139041		RING, RETAINING
110	1356090004		HUB - SHIFT COLLAR (MECH. SHIFT)
111	1356212002		CLUTCH HOUSING
112	1000139027		SNAP RING
113	1356640002		COIL ASSY - CLUTCH
114	207		BEARING
115	1000139027		SNAP RING
116	1356053003		SPEEDO GEAR RETAINER
117/129	T18-169		SPEEDO GEAR (7T)
117/129	T18-169D		SPEEDO GEAR (8T)
119	1356055001		COLLAR - LOCK UP (MECH. SHIFT)
120	1350156007		SLEEVE RETURN SPRING
121	1356089002		HUB - LOCK UP (ELEC. SHIFT)
122	1000139041		RETAINING RING
123	1356090002		HUB - SHIFT COLLAR (ELEC. SHIFT)
124	1300139027		SNAP RING
125	1345130001		BALL BEARING - REAR MAIN SHAFT
126	1300139027		SNAP RING
128	1356053003		RETAINER - SPEEDO GEAR

KITS

T1356R	→	BEARING, SEAL & GASKET KIT
K1356	→	GASKET & SEAL KIT
SP1356-50	→	SMALL PARTS KIT
PK1356	→	OIL PUMP KIT

We supply a full line of clutches for both light duty and heavy duty transmissions.



BW4404 STYLE

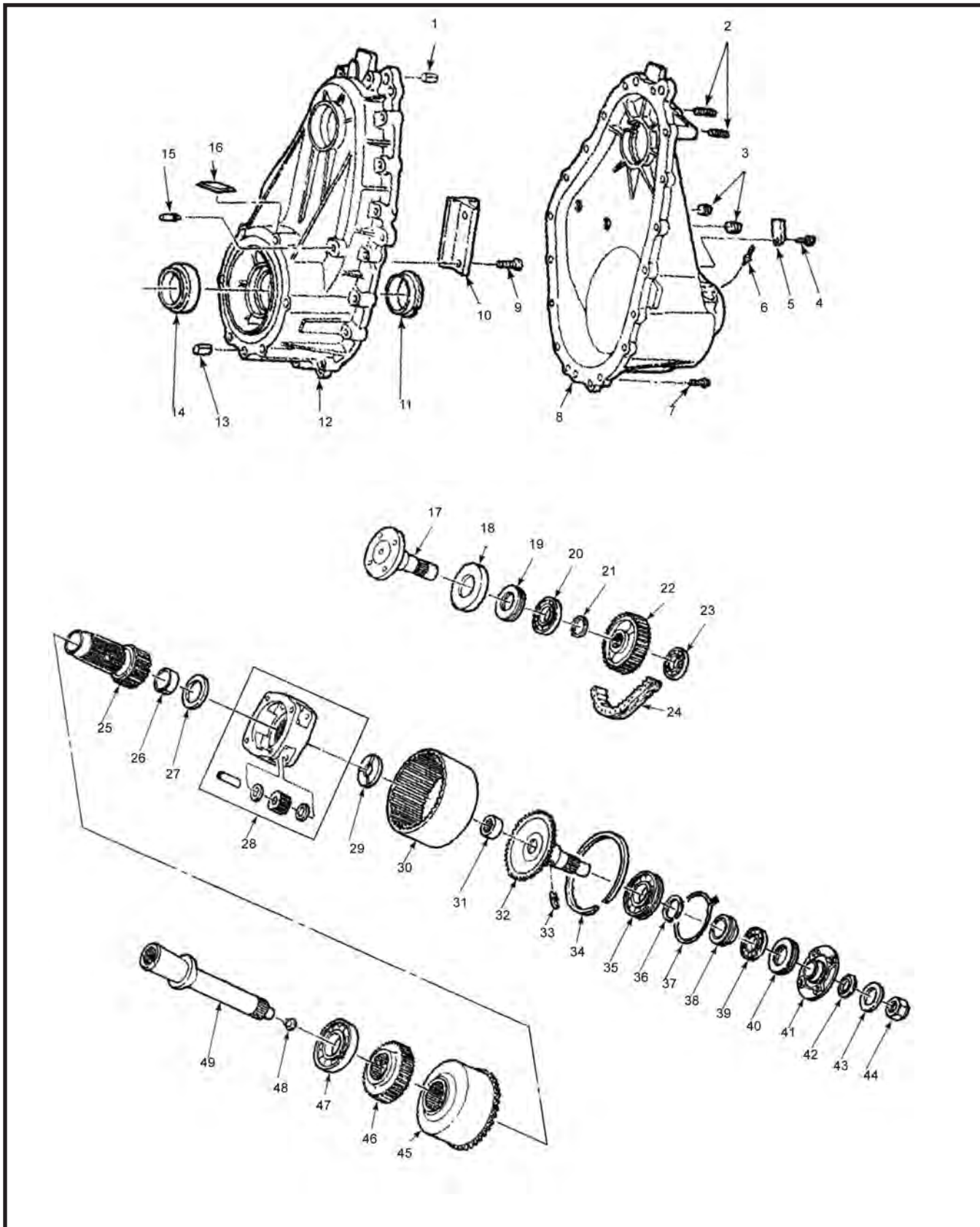

BW4404 STYLE (cont.)

ILL #	MIDWEST #	REF #	REPLACEMENT PART DESCRIPTION
1	1300043007		DOWEL PIN
2	1300146004		STUD
3	1900052008		DRAIN/FILL PLUG
4	1000191035		BOLT
5	XXX		I.D. TAB
6	1300146003		STUD
7	1900183023		BOLT - CASE
8	4404565001		FRONT CASE HALF ASSY - TAG# 001, 002, 003
8	4404565002		FRONT CASE HALF ASSY - TAG# 004
8	4404565003		FRONT CASE HALF ASSY - TAG# 005, 007
9	1900183008		BOLT
10	4400150001		DAMPER
11	1900127003		BUSHING - INPUT
12	4404539001		REAR CASE HALF ASSY - TAG# 001, 005
12	4404539003		REAR CASE HALF ASSY - TAG# 006
13	1000043017		DOWEL PIN
14	1900044012		SEAL - INPUT
15	1345072001		BARB - BREATHER
16	XXX		DECAL
17	4404671002		FRONT OUTPUT SHAFT
17	4404671003		FRONT OUTPUT SHAFT
17	4404671006		FRONT OUTPUT SHAFT
17	4404671004		FRONT OUTPUT SHAFT
18	1350035002		DUST SHIELD
19	1900044012		OIL SEAL - FRONT OUTPUT
20	207L	BEARING - FRONT OUTPUT SHAFT	
21	1372053002	SPACER	
22	4404144002	CHAIN SPROCKET, DRIVEN	
23	206L	BEARING - FRONT OUTPUT SHAFT	
24	HV051	CHAIN	
24	HV070	CHAIN WITH 5 LITER	
25	4404665001	SUN GEAR ASSY	
26	1900127004	SHAFT BUSHING	
27	1900193005	THRUST WASHER	
28	4472659003	PLANETARY ASSY	
29	1900193006	THRUST WASHER	
30	1372162001	RING GEAR, PLANETARY	
31	SCH1310	CAGED NEEDLE	
32	4404171002	MAIN SHAFT ASSY - TAG# 001-005	
32	4404171003	MAIN SHAFT ASSY - TAG# 006	
33	1900034001	OIL SCOOP	
34	1900139001	RETAINING RING	
35	6206	MAIN SHAFT BEARING - FRONT	
36	1900139045	SNAP RING	
37	1900139057	RETAINING RING	
38	1900110004	SPEEDOMETER DRIVE GEAR	
39	16006	MAIN SHAFT BEARING - REAR	
40	1900044017	OIL SEAL - REAR OUTPUT	
41	4400031009	FLANGE - REAR OUTPUT	
42	1900044002	RUBBER SEAL	
43	1000047016	WASHER	
44	1900149001	NUT	
45	4404625001	VISCOUS CLUTCH ASSY	
46	4404144001	CHAIN SPROCKET DRIVE	
47	109L	BALL BEARING, INPUT	
48	1352034002	OIL TUBE	
49	4404689001	INPUT SHAFT ASSY	
N.I.	1900127016	FRONT CASE BUSHING (BETWEEN INPUT & CASE)	

KITS

T4404R	➔ BEARING KIT
K4404	➔ GASKET & SEAL KIT

BW4405 STYLE FORD® EXPLORER (ELECTRIC SHIFT)

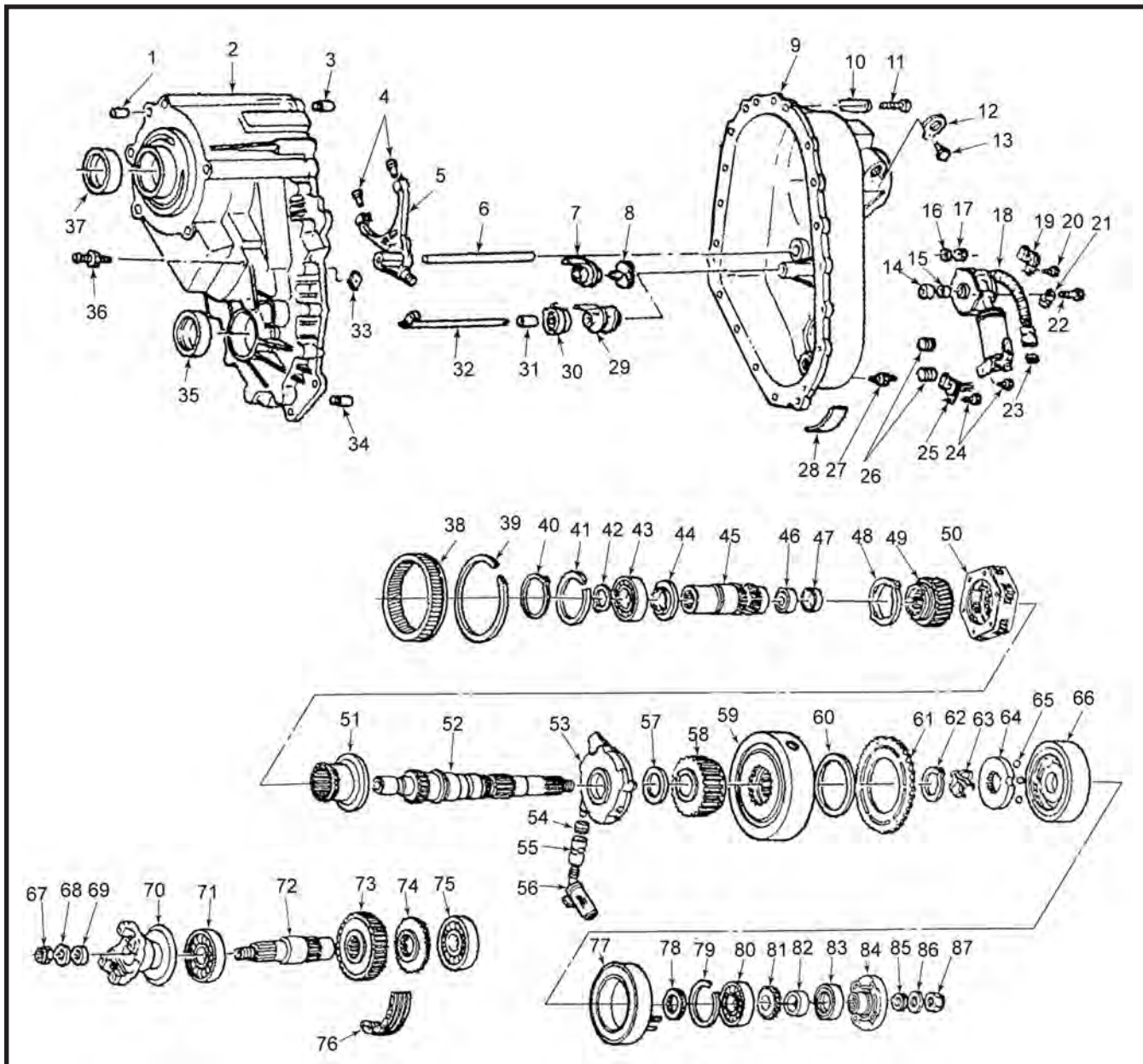

BW4405 STYLE (cont.)

ILL #	MIDWEST #	REF #	REPLACEMENT PART DESCRIPTION
1/3/34	1900043008		DOWEL PIN
2	4405565007		FRONT CASE HALF ASSY 1995-96 - TAG# 007
2	4405565009		FRONT CASE HALF ASSY 1997-98 - TAG# 008, 010
2	4405565008		FRONT CASE HALF ASSY 1998-99 - TAG# 011, 012
4	1356235001		FORK PADS (2 REQ.)
5	4405596002		SHIFT FORK - ALL
6	4405100001		SHIFT RAIL
7	4405099013		SHIFT CAM 1998-ON - TAG# 010, 011, 012
8	4405099014		SHIFT CAM 1998-ON - TAG# 010, 011, 012
9	4405539004		REAR CASE HALF ASSY 1995-97 - TAG# 007,008
9	4405539007		REAR CASE HALF ASSY 1998 - TAG# 010
9	4405539008		REAR CASE HALF ASSY 1998-99 - TAG# 011, 012
11/20/24	1900183009		BOLT
12	1356014002		PLATE, SPEEDO
13	1300146003		BOLT
14	1300127002		SLEEVE (SELF LUBE)
15	330385		SEAL - SHIFT SHAFT
16	1900047004		WASHER
17	1300149002		NUT
18	4405648006		SHIFT MOTOR ASSY - ALL
19	4400640006		SPEED SENSOR - UPPER
21	1900056004		J-CLIP (2 REQ.)
22	1900183012		BOLT
23	1900056003		CONNECTOR - RETAINER
25	4400640007		SPEED SENSOR - LOWER
26	1300052003		PIPE PLUG
27	1900146004		STUD
29	4405099009		SHIFT CAM 1995-97 - TAG# 007, 008
30	1350156008		SPRING
31	1350053002		SPACER, SHAFT
32	1354122002		SHIFT SHAFT
33	1000012002		MAGNET
35/37	1900044009		FRONT SEAL - OIL (2 REQ.)
36	1900072005		BARB - BREATHER - ASSY #4405 - TAG# 010
36	1300072001		BARB - BREATHER - EXC. ASSY BELOW
38	1354162001		RING GEAR
39	1900139026		RETAINING RING
40	1900139034		SNAP RING
41	1000139043		SNAP RING
42	1000139040		SNAP RING
43	209L		BEARING, INPUT
44	4405179005		HUB, CIRCULAR
45	4405689001		INPUT SHAFT ASSY (INCLUDES BEARING & BUSHING)
45	4405189001		INPUT SHAFT
46	M18161		BEARING, INPUT POCKET
47	1345127002		BUSHING, INPUT POCKET
48	1350014001		THRUST PLATE
49	1350165001		SUN GEAR
50	1354659002		PLANETARY ASSY
51	1354089002		RANGE HUB
52	4405671002		MAIN SHAFT ASSY (INCLUDES PUMP)
52	4405171003		MAIN SHAFT
53	4400508004		PUMP ASSY
54	1900056007		HOSE CLAMP
55	1900034008		HOSE
56	4400238002		FILTER
57	1900193020		THRUST WASHER
58	4405644001		SPROCKET ASSY, DRIVE (ALL EXC. BELOW)
58	4405644002		SPROCKET ASSY, DRIVE 1" CHAIN - TAG #012
N.I.	1900127009		BUSHING (USE 4405644001)
N.I.	1900127012		BUSHING (USE 4405644002)
58	4405144005		SPROCKET w/o BUSHING (ALL EXC. BELOW)
58	4405144007		SPROCKET w/o BUSHING 1" CHAIN - TAG# 012
59	4405625003		CLUTCH PACK ASSY
60	4400248001		WASHER, INSULATOR
61	4405147004		ARMATURE
62	1900139039		RETAINING RING

BW4405 STYLE (cont.)

ILL #	MIDWEST #	REF #	REPLACEMENT PART DESCRIPTION
63	1900156006		WAVE SPRING
64	4405099011		APPLY CAM
65	1900109002		BALL (3 REQ.)
N.I.	4405099012		CAM
N.I.	4405212902		COIL HOUSING
66	4405712001		CAM & COIL ASSY
67	1900149001		NUT
68	1000047016		WASHER
69	1000044012		OIL SEAL
70	1300531005		YOKE, FRONT OUTPUT
71	306		BEARING, FRONT OUTPUT
72	4405171001		SHAFT - FRONT OUTPUT - TAG# 007
72	4405671006		SHAFT - FRONT OUTPUT - SHIELD - TAG# 008, 010, 011
72	4405171006		SHAFT - FRONT OUTPUT - TAG# 008, 010, 011
72	4405671007		SHAFT - FRONT OUTPUT - SHIELD - TAG# 012
72	4405171007		SHAFT - FRONT OUTPUT - TAG# 012
N.I.	1350035002		SHIELD (DUST DEFLECTOR)
73	4405144006		SPROCKET, DRIVEN (EXC. BELOW)
73	4405144008		SPROCKET, DRIVEN 1" CHAIN - TAG# 012
74	4405151005		STONE WHEEL - LOWER
75	206		BEARING, FRONT OUTPUT
76	HV051		CHAIN 1-1/4" WIDE - TO 1997
76	HV067		CHAIN 1" WIDE - 1998-ON
77	4400645001		ELEC. COIL ASSY
78	1900132008		THRUST BEARING
79	1900139007		RETAINING RING
80	306-H		BEARING, MAIN SHAFT
81	4405151006		STONE WHEEL
82	1900053024		SPEEDO GEAR SPACER
83	1900044009		OIL SEAL
84	1300031006		COMPANION FLANGE
85	1000044012		OIL SEAL
86	1000047016		WASHER
87	1900149001		NUT
N.I.	4405110001		SPEEDO GEAR (7+) - PLACED ON BACK OF M/S, LAST PART BEFORE CASE

KITS

T4405R	→ BEARING GASKET & SEAL KIT
K4405	→ GASKET & SEAL KIT

Motive Gear®

BW4406 STYLE

FORD® F150, 250 1996-98 / BRONCO, EXPEDITION 1997-98
(ELECTRIC, MECHANICAL, T.O.D.)

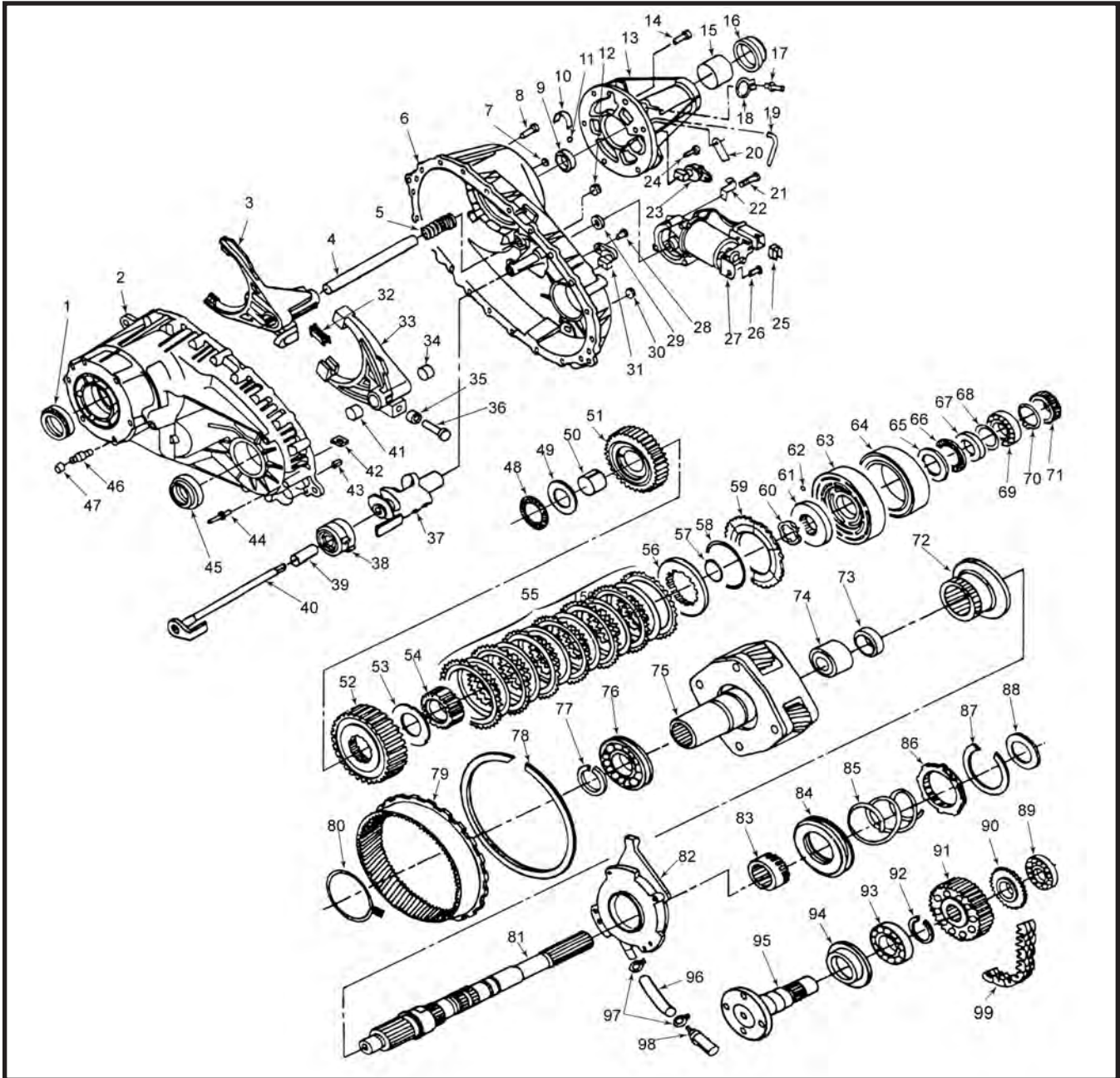

ILL #	MIDWEST #	REF #	REPLACEMENT PART DESCRIPTION
1	1900044012		INPUT SEAL - 1997 PICK-UP
1	1900044019		INPUT SEAL - ALL OTHERS
2	4406065004		FRONT CASE HALF - (MECH. SHIFT) 1996-97 PICK-UP
2	4406065005		FRONT CASE HALF - (ELEC. SHIFT) 1996-97 PICK-UP
2	4406065006		FRONT CASE HALF T.O.D. 1996-97 BRONCO, EXPEDITION
2	4406065007		FRONT CASE HALF - (MECH. SHIFT) 1998 PICK-UP
2	4406065008		FRONT CASE HALF - (ELEC. SHIFT) 1998-99 PICK-UP
2	4406065009		FRONT CASE HALF T.O.D. 1998-99 EXPEDITION
2	4406065010		FRONT CASE HALF - (MECH. SHIFT) 1999 PICK-UP
3	4406096002		MODE FORK- EXC. T.O.D. - 1996-97 PICK-UP

BW4406 STYLE (cont.)

ILL #	MIDWEST #	REF #	REPLACEMENT PART DESCRIPTION
3	4406096007		MODE FORK - EXC. T.O.D.- 1998-99 PICK-UP
3	4406096006		MODE FORK T.O.D. - 1996-97 BRONCO, EXPEDITION
3	4406096008		MODE FORK T.O.D. - 1998-99 EXPEDITION
4	4406100001		SHIFT RAIL - ALL - (EXC. BELOW)
4	4406100003		SHIFT RAIL - T.O.D.
5	4400156001		SPRING - FORK RETUR
6	4406539004		REAR CASE HALF ASSY - (MECH. SHIFT) 1996-97 PICK-UP
6	4405539005		REAR CASE HALF ASSY - (ELEC. SHIFT) 1996-97 PICK-UP
6	4406539006		REAR CASE HALF ASSY - TORQUE ON DEMAND 1996-97 BRONCO, EXPEDITION
6	4406539007		REAR CASE HALF ASSY - (MECH. SHIFT) 1998-99 PICK-UP
6	4406539008		REAR CASE HALF ASSY - (ELEC. SHIFT) 1998-99 PICK-UP
6	4406539009		REAR CASE HALF ASSY - T.O.D. 1998-99 EXPEDITION
7	1900016004		SEALING RING
8	1900183009		BOLT
9	1900053014		SPEEDO SPACER (ALL EXC. T.O.D.)
9	1900053018		SPEEDO SPACER (T.O.D.)
10	1900056021		SPEED RETAINER
11	1000109001		BALL, SPEEDO
12	1300052003		PLUG, FILL/DRAIN
13	4406566002		EXTENSION HOUSING - 1996-97 PICK-UP
13	4406566004		EXTENSION HOUSING - 1996-97 BRONCO, EXPEDITION
13	4406566006		EXTENSION HOUSING - 1999 PICK-UP, (MECH. SHIFT)
13	4406566008		EXTENSION HOUSING - 1999 PICK-UP, (ELEC. SHIFT)
13	4406566010		EXTENSION HOUSING - 1998-99 EXPEDITION T.O.D.
13	4406566012		EXTENSION HOUSING - 1998 PICK-UP, (MECH. SHIFT)
14	1900183009		BOLT
15	1356127001		BUSHING, EXTENSION
16	1900044013		SEAL - REAR OUTPUT
17	1900146008		STUD
18	1356014002		ISOLATOR PLATE
20	XXX		I.D. TAG
21	1900183012		BOLT
22	1900056004		J-CLIP
23	4400640019		SENSOR
24	1900183002		SCREW - METRIC
25	1900056009		HARNES CLIP
26	1900183002		SCREW
27	4406648001		SHIFT MOTOR - T.O.D. - BRONCO, EXPEDITION
27	4406648002		SHIFT MOTOR - PICK-UP
28	1900183012		BOLT
29	1300044001		SEAL, SHIFT SHAFT
30	1300052003		PLUG, FILL/DRAIN
31	1900640001		SENSOR
32	1356235001		FORK PAD (2 REQ.)
33	4406596003		RANGE FORK - 4406-008 AND 009 UNIT ONLY
33	4406596005		RANGE FORK - ALL
33	4406596004		RANGE FORK - ALL - 1996-98
34/41	1900127006		BUSHING
35	1352127001		ROLLER
36	1900043009		PIN - FORK ROLLER
37	4406099002		CAM - PICK-UP
37	4406099003		CAM - (MECH. SHIFT)
37	4406099004		CAM - T.O.D. - BRONCO, EXPEDITION
38	1356156006		TORSIONAL SPRING
39	1356053005		SPACER
40	4406122002		SHIFT SHAFT - PICK-UP - (ELEC. SHIFT)
40	4406122003		SHIFT SHAFT - BRONCO, EXPEDITION - (ELEC. SHIFT)
42	1000012002		MAGNET
43	1900043008		DOWEL PIN
44	1900146007		STUD - SHIELD
45	1900044012		OUTPUT SEAL
46	1345072001		BARB - BREATHER
47	4864W		CAP - BREATHER
48	AXK4060		THRUST BEARING T.O.D. ONLY
49	1900193035		THRUST WASHER (2 REQ.) T.O.D. ONLY
N.I.	1900053015		SPACER (ALL EXC. T.O.D.)
50	1900122012		BUSHING - SPROCKET
51	4406644001		DRIVE SPROCKET ASSY T.O.D. - BUSHING

BW4406 STYLE (cont.)

ILL #	MIDWEST #	REF #	REPLACEMENT PART DESCRIPTION
51	4406144002		DRIVE SPROCKET 1996-98 - 1-1/4" CHAIN, EXC. T.O.D.
51	4406144005		DRIVE SPROCKET 1999-ON - 1" CHAIN
52	4406625002		CLUTCH PACK ASSY - 1997 BRONCO
54	4406090001		SHIFT HUB, MODE 1996-98 PICK-UP
54	4406090002		SHIFT HUB, MODE 1999-ON PICK-UP
55	SEE #52		
57	1900139055		SNAP RING
58	4400248001		WASHER, INSULATOR
59	4405147004		ARMATURE - ALL T.O.D. (EXC. BELOW)
59	4406147003		ARMATURE 1999 EXPEDITION T.O.D.
60	1900156006		WAVE SPRING
61	4405099011		APPLY CAM T.O.D.
62	1900109002		BALL, APPLY CAM (3 REQ.)
63	4406712001		COIL HOUSING 1996-98 PICK-UP
63	4405712003		COIL HOUSING 1999-ON PICK-UP
63	4405712001		COIL HOUSING - ALL T.O.D. (EXC. BELOW)
63	4406712004		COIL HOUSING - 1999 EXPEDITION T.O.D.
64	4400645001		COIL - ALL (ELEC. SHIFT)
64	4400645007		COIL - ALL (MECH. SHIFT)
64	4400645006		COIL - ALL T.O.D.
N.I.	1300149002		NUT
65	1900018003		THRUST RACE - T.O.D.
66	1900132006		THRUST BEARING - T.O.D. ONLY
67	1900018004		THRUST RACE
68	1300139027		SNAP RING (2 REQ.)
69	207L		BEARING, MAIN SHAFT REAR (2 REQ.)
70	1300139027		SNAP RING (2 REQ.)
71	T18-169D		SPEEDO GEAR
71	4406151004		SPEEDO GEAR
71	4406151002		SPEEDO GEAR - ALL (EXC. ABOVE)
72	4407089003		REDUCTION HUB
73	1345127002		BEARING SLEEVE
74	1300132015		NEEDLE BEARING, INPUT POCKET
75	4406659002		PLANETARY ASSY 1996-98 PICK-UP T.O.D.
75	4406659003		PLANETARY ASSY 1996-98 BRONCO, EXPEDITION
75	4406659006		PLANETARY ASSY 1999-ON PICK-UP
75	4406659008		PLANETARY ASSY 1999-ON EXPEDITION
76	211L		BEARING, INPUT
77	1900139042		SNAP RING
78	1300139012		RETAINING RING
79	4407162001		RING GEAR
80	1900139043		RETAINING RING - (EXC. T.O.D.)
80	1900139049		RETAINING RING - T.O.D.
81	4406171005		MAIN SHAFT - PICK-UP TO 1998, EXC. T.O.D.
81	4406171006		MAIN SHAFT - BRONCO, EXPEDITION TO 1998 T.O.D.
81	4406171007		MAIN SHAFT - PICK-UP 1999-ON
81	4406171008		MAIN SHAFT - EXPEDITION 1999-ON
81/82	4406671005		OUTPUT SHAFT & PUMP ASSY
81/82	4406671006		OUTPUT SHAFT & PUMP ASSY, (EXC. T.O.D.)
82	4400508006		OIL PUMP ASSY
83	4406179001		MODE HUB (INNER) - ALL T.O.D. (EXC. BELOW)
83	4406179002		MODE HUB (INNER) - 1999 EXPEDITION T.O.D.
84	4400589003		COLLAR ASSY - ALL EXC. T.O.D. AND BELOW
84	4406589002		COLLAR ASSY - 1999 PICK-UP
84	4406589003		COLLAR ASSY - ALL T.O.D.
85	1900156009		SPRING - ALL (EXC. T.O.D.)
85	1900156008		SPRING - T.O.D.
86	4400147001		ARMATURE
87	1900139044		SNAP RING - ALL (EXC. T.O.D.)
87	1900139050		SNAP RING - T.O.D.
89	207L		FRONT OUTPUT SHAFT BEARING (REAR) (2 REQ.)
90	4406151001		tone wheel
91	4406144001		SPROCKET, DRIVEN - 1-1/4" CHAIN
91	4406144004		SPROCKET, DRIVEN - 1" CHAIN
92	1900139054		SNAP RING
93	208L		FRONT OUTPUT SHAFT BEARING (FRONT)
94	1300035001		SHIELD
95	4406671007		SHAFT - FRONT OUTPUT
96	1900034009		HOSE, OIL PUMP

BW4406 STYLE (cont.)

ILL #	MIDWEST #	REF #	REPLACEMENT PART DESCRIPTION
97	1900056007		HOSE CLAMP (2 REQ.)
98	4400238003		FILTER
99	HV052		CHAIN - 1-1/4" - 1996-98 EXC. T.O.D.
99	HV053		CHAIN - 1-1/4" - 1996-ON T.O.D.
99	HV066		CHAIN - 1" 1998-ON EXC. T.O.D.
N.I.	4406598001		SHIFT LEVER & SHAFT - (MECH. SHIFT)
N.I.	1300183019		CAM SET SCREW - (MECH. SHIFT)
N.I.	1900156007		SPRING CAM - (MECH. SHIFT)
N.I.	1300127008		ROLLER, SHIFT CAM - (MECH. SHIFT)

KITS

T4406R	→ BEARING GASKET & SEAL KIT
K4406	→ GASKET & SEAL KIT



Light Duty & Performance Application Guide

This catalog features stock performance and high performance ring and pinions for street, track, and off road applications; as well as installation components: axles, hubs, gear oils, posi units, lockers, spools, ring gear spacers, bearing kits, gaskets, and more!

BW4407 STYLE FORD® F250, F350 (MECHANICAL SHIFT, WITH OR WITHOUT PTO)

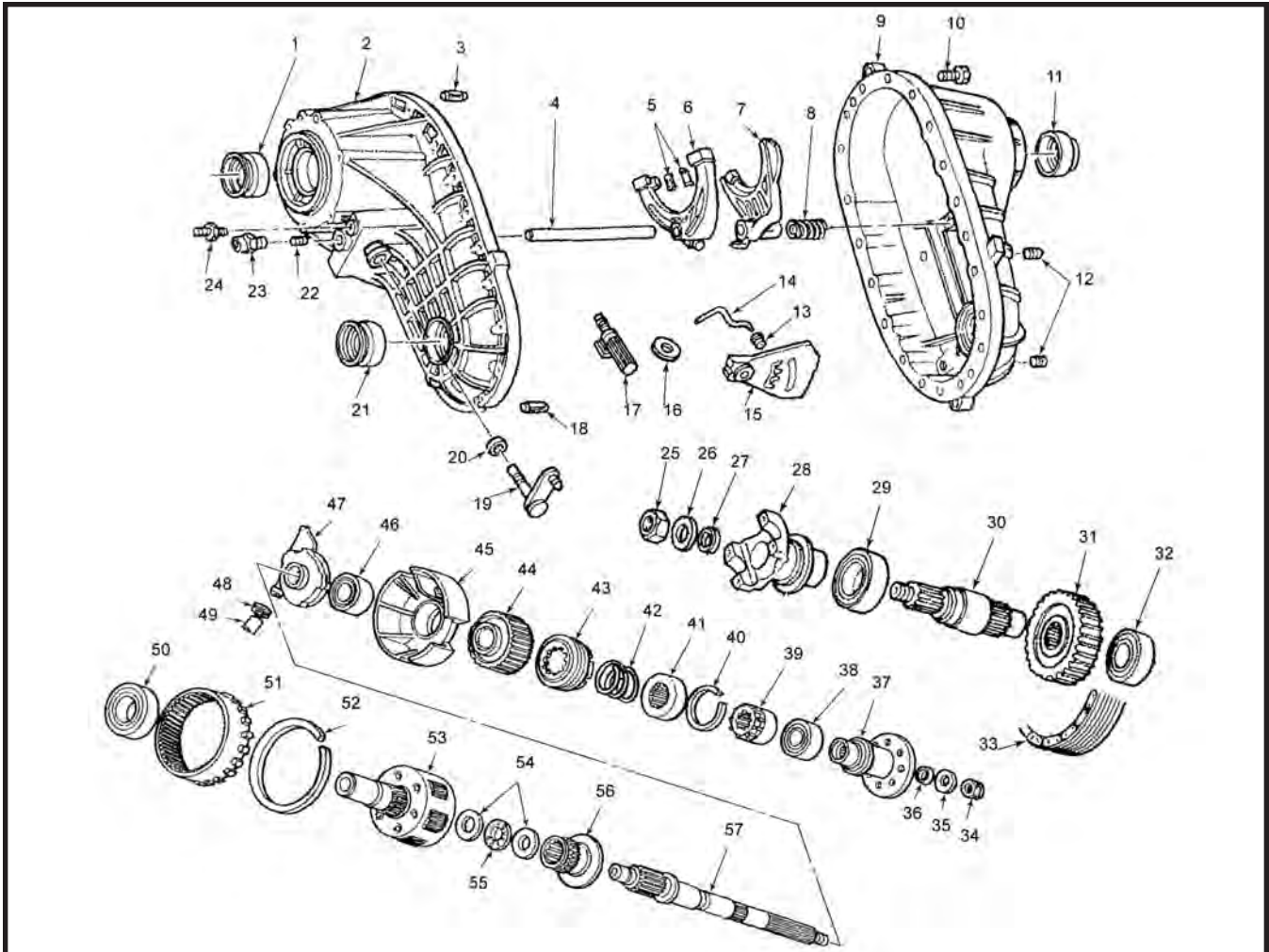

ILL #	MIDWEST #	REF #	REPLACEMENT PART DESCRIPTION
1	1900044012		SEAL - INPUT
2	4407565002		FRONT CASE HALF ASSY - w/o PTO
2	4407565001		FRONT CASE HALF ASSY - w/ PTO
3	1900043008		DOWEL PIN
4	4407100001		RAIL - SHIFT FORKS
5	1356235001		FORK PADS, RANGE (2 REQ.)
6	4407596003		FORK - RANGE
7	4407096002		FORK - MODE
8	4400156001		SPRING MODE FORK
9	4407539001		REAR CASE HALF ASSY (INCLUDES BEARINGS & SEAL)
9	4407039001		REAR CASE HALF (NO BEARINGS & SEAL)
10	1900183019		BOLT, CASE (20 REQ.)
11	1900044012		SEAL, REAR OUTPUT
12	1900052008		PLUG, DRAIN/FILL
13	1300127008		ROLLER, DETENT
14	1900156007		SPRING, DETENT ROLLER
15	4407099001		CAM, SHIFT
16	4915E		MAGNET
17	4400238003		FILTER SCREEN
19	4407598001		SHIFT LEVER ASSY
20	1900044011		SEAL, SHIFT LEVER

BW4407 STYLE (cont.)

ILL #	MIDWEST #	REF #	REPLACEMENT PART DESCRIPTION
21	1900044012		SEAL - FRONT OUTPUT
22	1300183019		SET SCREW
23	1300140003		SWITCH
24	1345072001		BREATHER BARB
N.I.	1300183019		SET SCREW, CAM
25	1900149002		NUT, FRONT OUTPUT YOKE
26	1900047005		WASHER, FRONT OUTPUT YOKE
27	1300016002		SEALING RING, FRONT OUTPUT SPLINES
28	4400531003		FRONT OUTPUT YOKE, DOUBLE CARDAN (EXC. BELOW)
28	4400531007		FRONT OUTPUT YOKE, SINGLE CARDAN - MODEL #4407-002, 004
N.I.	1300035001		SLINGER, FRONT OUTPUT YOKE
29	208		BEARING, FRONT OUTPUT SHAFT - OUTER
30	4407171001		SHAFT, FRONT OUTPUT
31	4407144002		SPROCKET, DRIVEN
32	207		BEARING, FRONT OUTPUT SHAFT - INNER
N.I.	B2012		BEARING, FRONT OUTPUT SHAFT - PILOT
33	HV054		CHAIN, DRIVE 1-1/2" WIDE
34	1900149002		NUT, REAR YOKE
35	1900047005		WASHER, REAR YOKE
36	1300016002		SEALING RING
37	4400531008		CIRCULAR FLANGE
N.I.	1300035001		SLINGER, FLANGE
38	308L		BEARING, REAR OUTPUT
39	4407090002		SHIFT COLLAR HUB
40	1900139041		SNAP RING
41	4407089001		HUB, LOCKUP
42	1900156008		SPRING, LOCKUP
43	4407589002		LOCKUP COLLAR ASSY
44	4407144001		SPROCKET, DRIVE
45	4407607001		RETAINER AND BEARING ASSY
45	4407107001		RETAINER ONLY
46	210		BEARING, MAIN SHAFT CENTER
47	4400508006		OIL PUMP ASSY MODEL #4407-001, 002, 003
47	4400508009		OIL PUMP ASSY MODEL #4407-004, 005, 006
48	1900056007		CLAMP, PICKUP HOSE
49	1900034009		HOSE, OIL PUMP PICKUP
50	211		BEARING, INPUT
51	4407162001		RING GEAR, PLANETARY
52	1300139012		SNAP RING, RING SEAL
53	4407659002		PLANETARY ASSY - INPUT, - w/ PTO
53	4407659003		PLANETARY ASSY - INPUT, w/o PTO
54	1900018003		RACE, THRUST NEEDLE BEARING (2 REQ.)
55	1900018003		NEEDLE BEARING, THRUST #NTA2233
56	4407089003		HUB, RANGE SHIFT
N.I.	BK3026		POCKET BEARING, PLANETARY INPUT
57	4407671002		MAIN SHAFT ASSY - w/ PUMP - TAG# 001, 002, 003
57	4407671001		MAIN SHAFT ASSY w/o PUMP - TAG# 001,002, 003
57	4407171003		MAIN SHAFT - TAG# 001, 002, 003
57	4407171002		MAIN SHAFT - TAG# 004, 005, 006

KITS

T4407R	→	BEARING, GASKET & SEAL KIT
K4407	→	GASKET & SEAL KIT

BW4410 STYLE

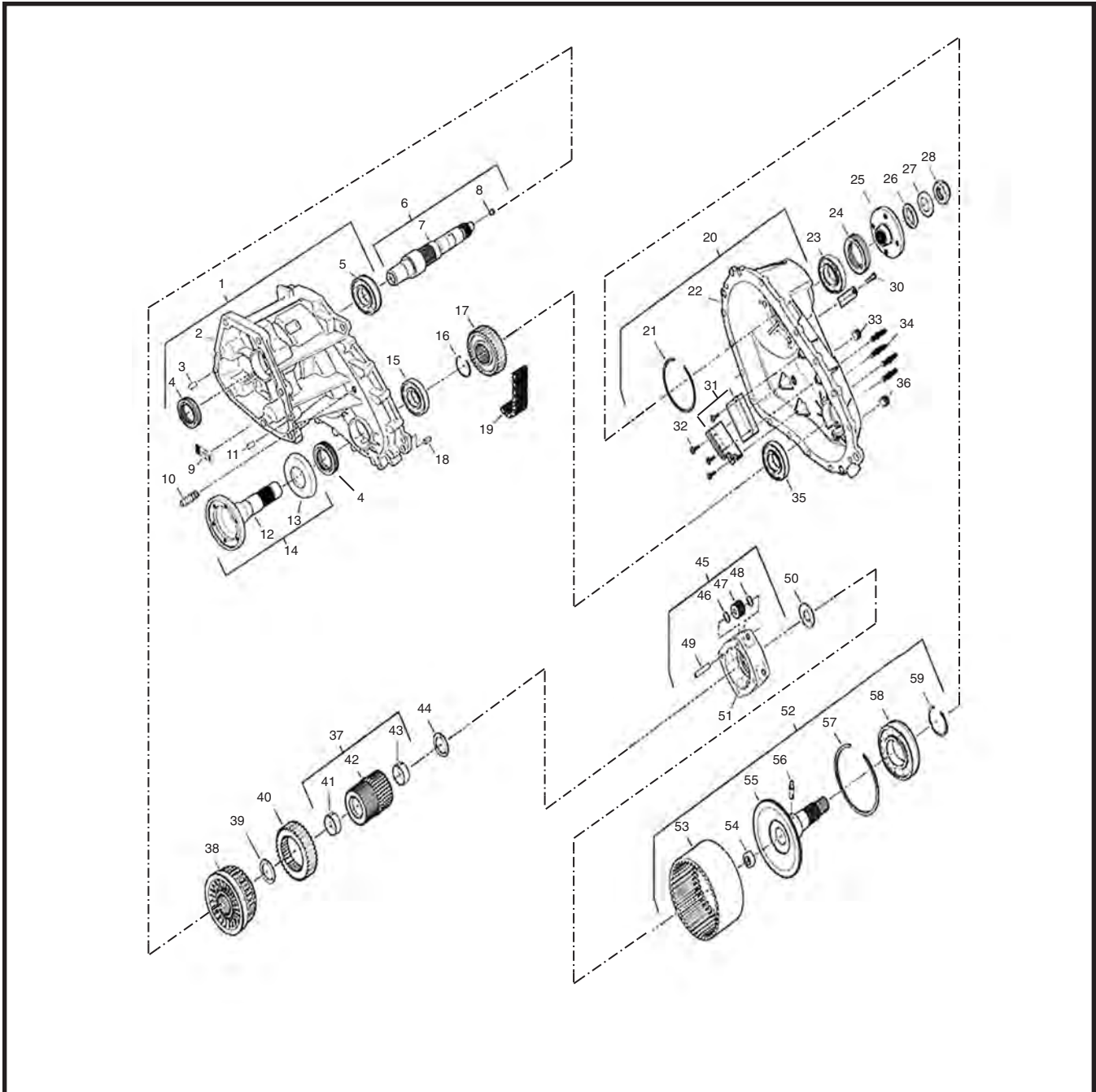

ILL #	MIDWEST #	REF #	REPLACEMENT PART DESCRIPTION
1	4410565001		FRONT CASE HALF ASSY
2	4410065001		FRONT CASE HALF (EMPTY)
3/11	1900043014		SOLID DOWEL PIN (2 USED)
4	1900044009		INPUT OIL SEAL
5	1345130001		INPUT BEARING
6	4410689001		INPUT SHAFT ASSY
7	4410189001		INPUT SHAFT
8	1352034002		OIL FUNNEL
10	1900072005		BREATHER
12	4411171001		OUTPUT SHAFT
13	1350035002		DEFLECTOR SHIELD
14	4411671001		OUTPUT SHAFT ASSY

BW4410 STYLE (cont.)

ILL #	MIDWEST #	REF #	REPLACEMENT PART DESCRIPTION
15	1900130008		FRONT OUTPUT BEARING
16	1300139027		SNAP RING
17	4404144002		DRIVEN SPROCKET - USED w/TAG #'S: 4410-004
17	4410144003		DRIVEN SPROCKET - USED w/TAG #'S: 4410-005, 6, 7, 8
18	1900043008		DOWEL PIN (2 USED)
19		4400143026	CHAIN - USED w/TAG #'S: 4410-004, 5
19	HV078	4400143027	CHAIN - USED w/TAG #'S: 4410-006, 7, 8
20	4410539004		REAR CASE HALF ASSY
21	1900139057		SNAP RING
22	4410039003		REAR CASE HALF (EMPTY)
23	1900130018		REAR OUTPUT BEARING
24	1900044009		REAR OUTPUT SEAL
25	4400031023		REAR OUTPUT FLANGE
26	1000044012		REAR OUTPUT FLANGE SEAL
27	1000047016		REAR OUTPUT FLANGE WASHER
28	1900149001		REAR OUTPUT FLANGE NUT
30	1900183024		BOLT (17 USED)
31	4400150001		DAMPER SNUBBER - CHAIN SHIELD (2 USED)
32	1900183008		DAMPER SNUBBER SCREW (2 PER)
33/36	1900052008		PIPE PLUG - FILL & DRAIN PLUG (2 USED)
34	1900146004		STUD (4 USED)
35	1000130008		REAR FRONT OUTPUT BEARING
37	4410665001		SUN GEAR ASSY
38	4400625001		VISCOUS COUPLING
39/44	1900193045		THRUST WASHER
40	4410144001		DRIVE SPROCKET - USED w/TAG #'S: 4410-004
40	4410144002		DRIVE SPROCKET - USED w/TAG #'S: 4410-005, 6, 7, 8
41-43	1900127028		SUN GEAR BUSHING (2 REQ.)
42	4410165001		SUN GEAR
45	4472659003		PLANETARY CARRIER ASSY
46/48	1900193001		PINION GEAR THRUST WASHER (8 USED)
47	4472163001		PINION GEAR (4 USED)
49	1900042002		PINION SHAFT (4 USED)
50	1900193006		THRUST WASHER
51	4472659001		CARRIER
52	4410671001		REAR OUTPUT SHAFT ASSY
53	4410162901		RING GEAR
54	1900132001		REAR OUTPUT SHAFT POCKET NEEDLE BEARING
55	4410171001		REAR OUTPUT SHAFT
56	1900034001		OIL SCOOP
57	1900139001		RING GEAR RETAINING RING
58	1900130001		BEARING
59	1900139045		SNAP RING

KITS

T4410R	→ BEARING, SEAL & GASKET KIT
K4410	→ GASKET & SEAL KIT

BW4411 STYLE FORD® AVIATOR, EXPLORER, 2001-ON

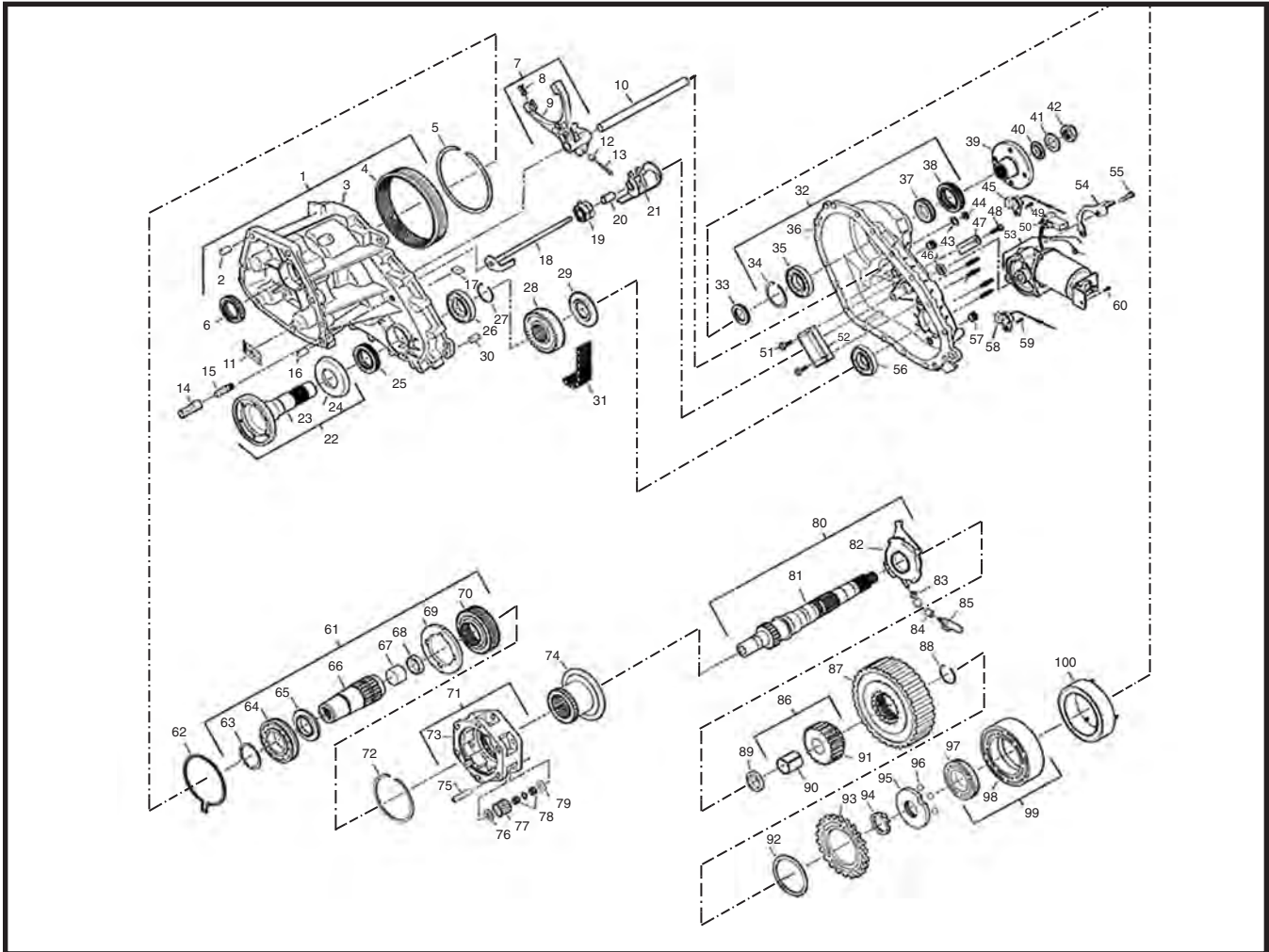

ILL #	MIDWEST #	REF #	REPLACEMENT PART DESCRIPTION
1	4411565001		FRONT CASE HALF ASSEMBLY (EXPLORER)
	4411565002		FRONT CASE HALF ASSEMBLY (AVIATOR)
2	1900043014		FRONT CASE HALF - SOLID DOWEL PIN
3	4411065001		FRONT CASE HALF (EXPLORER)
	4411065002		FRONT CASE HALF (AVIATOR)
4	1354162001		FRONT CASE HALF - RING GEAR (EXPLORER ONLY)
5	1900139026		FRONT CASE HALF - RING GEAR RETAINING RING (EXPLORER ONLY)
6	1900044009		FRONT CASE HALF - INPUT OIL SEAL
7	4411596001		SHIFT FORK ASSEMBLY
8	1356235001		SHIFT FORK - PAD (EXPLORER ONLY)
9	4411096001		SHIFT FORK - (EXPLORER ONLY)
10	4405100001		SHIFT FORK - RAIL (EXPLORER ONLY)
11			
12	1352127001		SHIFT FORK - ROLLER (EXPLORER ONLY)
13	1900043009		SHIFT FORK - PIN (EXPLORER ONLY)
14	1900191023		BREATHER - PLUG
15	1900072005		BREATHER - BARB HOSE
16	1900043014		FRONT CASE HALF - SOLID DOWEL PIN
17	1000012002		MAGNET
18	4411122001		SHIFT SHAFT (EXPLORER ONLY)
19	1350156008		SPRING (EXPLORER ONLY)
20	1350053002		SPACER (EXPLORER ONLY)
21	4405099009		CAM (EXPLORER ONLY)

BW4411 STYLE (cont.)

ILL #	MIDWEST #	REF #	REPLACEMENT PART DESCRIPTION
22	4411671001		OUTPUT SHAFT ASSEMBLY
23	4411171001		OUTPUT SHAFT (SHAFT ONLY)
24	1350035002		OUTPUT SHAFT DUST DEFLECTOR
25	1900044009		FRONT CASE HALF - INPUT OIL SEAL
26	207	1345130001	FRONT CASE HALF - BEARING
27	1300139027		FRONT CASE HALF - RETAINING RING
28	4405144008		SPROCKET (LOWER)
29	4405151005		TOPE WHEEL (LOWER)
31	HV067	4400143014	CHAIN .4346 PITCH X 1" WIDE X 74 PITCHES
32	4411539002		REAR CASE HALF ASSEMBLY (EXPLORER) TAG# 4411000003
	4411539003		REAR CASE HALF ASSEMBLY (AVIATOR)
	4411539004		REAR CASE HALF ASSEMBLY (EXPLORER) TAG# 4411000005, 7, 8
	4411539005		REAR CASE HALF ASSEMBLY (EXPLORER) TAG# 4411000009, 11, 13
33	1900132008		THRUST BEARING
34	1900139007		REAR CASE HALF - RETAINING RING
35	306-H	1900130010	REAR CASE HALF - REAR OUTPUT BEARING
36	4411039002		REAR CASE HALF (EXPLORER) - TAG# 4411000003, 5, 7, 8
	4411039003		REAR CASE HALF (AVIATOR)
	4411039004		REAR CASE HALF (EXPLORER) - TAG# 4411000009, 11, 13
37	4405151006		REAR CASE HALF - TONE WHEEL (UPPER)
38	710403	1900044009	REAR CASE HALF - SEAL
39	4400031029		REAR OUTPUT FLANGE
40	1000044012		REAR OUTPUT FLANGE - OIL SEAL
41	1900047007		REAR OUTPUT FLANGE - WASHER
42	1900149014		REAR OUTPUT FLANGE - NUT
43	1900047004		WASHER (3 REQ.)
44	1300149002		NUT (3 REQ.)
45	4400640043		SENSOR
46	330385	1300044001	REAR CASE HALF - SHIFT SHAFT - SEAL
48	1900183036		BOLT/WASHER (17 REQ.) - TAG# 4411000003 THRU 10
	1900183034		BOLT (17 REQ.) TAG# 4411000011 THRU 14
49	1900183002		HEX HEAD CAP SCREW
50	4400640068		CONNECTOR ASSEMBLY - TAG# 4411000006
	4400640063		CONNECTOR ASSEMBLY - TAG# 4411000004
51	1900183008		REAR CASE HALF - TORX SCREW (2 REQ.)
52	4400150001		REAR CASE HALF - SNUBBER
53	4411648004		ELECTRIC MOTOR - TAG# 4411000003, 5, 7, 8
	4411648007		ELECTRIC MOTOR - TAG# 4411000009, 11, 13
54	4411185002		CONNECTOR BRACKET - TAG# 4411000003, 4, 5, 6, 7, 8, 10, 12, 14
	4411085003		CONNECTOR BRACKET - TAG# 4411000009, 11, 13
55	1900183012		BOLT (3 REQ.) - TAG# 4411000003, 5, 7, 8, 9, 11, 13
56	206	1000130008	REAR CASE HALF - BEARING
57	1900052008		DRAIN/FILL PLUG (2 REQ.)
58	4400640044		SENSOR (LOWER)
59	1900083002		HEX HEAD CAP SCREW
61	4411689002		INPUT SHAFT ASSEMBLY (EXPLORER)
	4411689004		INPUT SHAFT ASSEMBLY (AVIATOR)
N.I.	1900053030		INPUT SHAFT - SPACER (AVIATOR)
62	1900139034		SNAP RING
63	100139040		INPUT SHAFT - SNAP RING
64	209-LO	1900130008	INPUT SHAFT - BEARING
65	4405179005		INPUT SHAFT - CIRCULAR HUB - TAG# 4411000003, 5, 7, 8, 9, 11, 13
66	4411189002		INPUT SHAFT
67	4840G	1900132013	INPUT SHAFT - POCKET BEARING
68	134512700		INPUT SHAFT - POCKET BUSHING
69	1350014001		INPUT SHAFT - THRUST PLATE - TAG# 4411000003, 5, 7, 8, 9, 11, 13
70	1350165001		INPUT SHAFT - SUN BEAR - TAG# 4411000003, 5, 7, 8, 9, 11, 13
71	1354659002		CARRIER ASSEMBLY - TAG# 4411000003, 5, 7
	1354659005		CARRIER ASSEMBLY - TAG# 4411000008, 9, 11, 13
72	1000139043		SNAP RING
73	1354659001		CARRIER - TAG# 4411000003, 5, 7
	1354659004		CARRIER - TAG# 4411000008, 9, 11, 13
74	1354089002		REDUCTION HUB
75	1350042001		CARRIER PINION SHAFT (6 REQ. FOR TAG# 4411000003, 5, 7) (4 REQ. FOR TAG# 4411000008, 9, 11, 13)
76	1350193002		CARRIER THRUST WASHER (12 REQ. FOR TAG# 4411000003, 5, 7) (8 REQ. FOR TAG# 4411000008, 9, 11, 13)

BW4411 STYLE (cont.)

ILL #	MIDWEST #	REF #	REPLACEMENT PART DESCRIPTION
77	1350163001		CARRIER PINION GEAR (6 REQ. FOR TAG# 4411000003, 5, 7) (4 REQ. FOR TAG# 4411000008, 9, 11, 13)
78	1300131001		CARRIER NEEDLE ROLLER (168 REQ. FOR TAG# 4411000003, 5, 7) (112 REQ. FOR TAG# 4411000008, 9, 11, 13)
78A	1350053001		CARRIER SPACER (6 REQ. FOR TAG# 4411000003, 5, 7) (4 REQ. FOR TAG# 4411000008, 9, 11, 13)
79			(SEE #76)
80	4405671008		MAIN SHAFT ASSEMBLY
81	4405171008		MAIN SHAFT
82	4400508004		MAIN SHAFT - OIL PUMP
83	1900056007		HOSE CLAMP
84	1900034008		HOSE
85	4400238002		FILTER
86	4405644002		SPROCKET (UPPER) ASSEMBLY
87	4424625001		CLUTCH PACK ASSEMBLY - TAG# 4411000003 THRU 12
	4411625001		CLUTCH PACK ASSEMBLY - TAG# 4411000013, 14
88	1900139039		SNAP RING
89	1900053027		THRUST WASHER SPACER
90	1900127012		SPROCKET (UPPER) - BUSHING
91	4405144007		SPROCKET (UPPER)
92	4400248001		INSULATOR WASHER
93	4405147004		ARMATURE ASSEMBLY - TAG# 4411000003 THRU 12
	4416147001		ARMATURE ASSEMBLY - TAG# 4411000013, 14
94	1900156006		WAVE SPRING
95	4400099001		APPLY CAM
96	1900109002		APPLY CAM BALL
97	4400099002		CAM & COIL (CAM ONLY)
98	4405212902		CAM & COIL (COIL ONLY)
99	4400712001		CAM & COIL ASSEMBLY
100	4400645020		ELECTRIC COIL - TAG# 4411000003 THRU 9, 11, 13
	4400645035		ELECTRIC COIL - TAG# 4411000010, 12, 14
101	1900146004		REAR CASE HALF - BRACE SUPPORT STUD (4 REQ.) - TAG# 4411000003

KITS

T4411R	→	BEARING, SEAL & GASKET KIT
K4411	→	GASKET & SEAL KIT



BW4416 STYLE

FORD® EXPEDITION, NAVIGATOR 2001 & UP w/T.O.D.

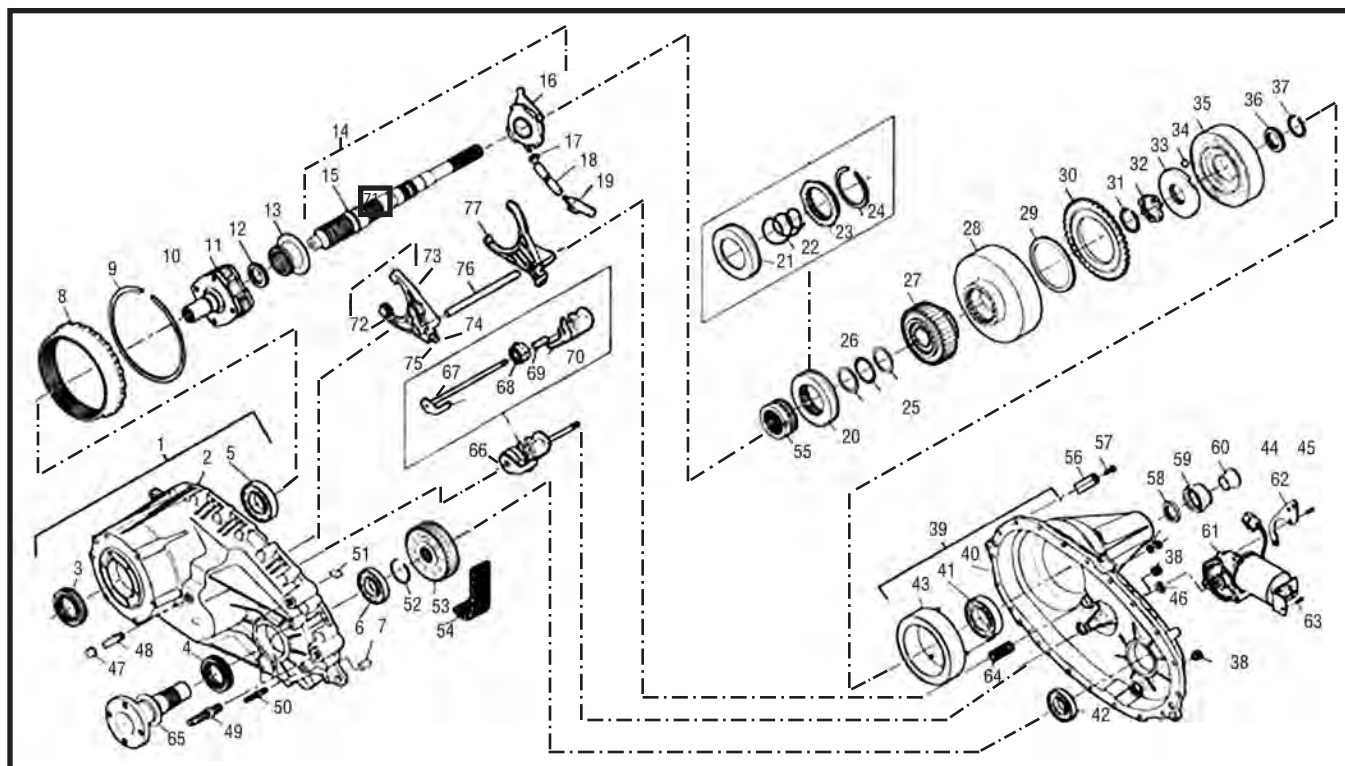

ILL #	MIDWEST #	REF #	REPLACEMENT PART DESCRIPTION
1	4416565001		FRONT CASE HALF ASSEMBLY (TAG #'S: 4416-002)
	4416565002		FRONT CASE HALF ASSEMBLY (TAG #'S: 4416-004 THRU 10)
	4416565003		FRONT CASE HALF ASSEMBLY (TAG #'S: 4416-011 THRU 14)
2	4416065001		FRONT CASE HALF (TAG #'S: 4416-002)
	4416065002		FRONT CASE HALF (TAG #'S: 4416-004 THRU 10)
	4416065003		FRONT CASE HALF (TAG #'S: 4416-011 THRU 14)
3	1900044012	3946, 1300044009	INPUT SEAL
4	1900044019	1300044019	FRONT OUTPUT SEAL
5	1900130020		INPUT BEARING
7	1900043008		DOWEL PIN
8	4407162001		PLANETARY RING GEAR
9	1300139012		PLANETARY RING GEAR RETAINING RING
10	4416689001		INPUT SHAFT ASSEMBLY w/NEEDLE BEARING (TAG #'S: 4416-002 THRU 6)
	4416689002		INPUT SHAFT ASSEMBLY w/NEEDLE BEARING (TAG #'S: 4416-007 THRU 14)
	4416189001		INPUT SHAFT (TAG #'S: 4416-002 THRU 6)
	4416189002		INPUT SHAFT (TAG #'S: 4416-007 THRU 14)
11	4416659001		COMPLETE PLANETARY ASSEMBLY w/ INPUT SHAFT (TAG #'S: 4416-002 THRU 6)
	4416659002		COMPLETE PLANETARY ASSEMBLY w/ INPUT SHAFT (TAG #'S: 4416-007 THRU 14)
12	1300132015		NEEDLE BEARING
13	4400089001		REDUCTION HUB (TAG #'S: 4416-002, 4)
	4400089002		REDUCTION HUB (TAG #'S: 4416-005 THRU 14)
14	4416671003		MAINSHAFT AND PUMP ASSEMBLY
15	4416171004		MAINSHAFT
16	4400508013		OIL PUMP
17	1900056007		HOSE CLAMP
18	1900034009		HOSE
19	4400235003		PICKUP AND FILTER
20	4416589001		LOCKUP COLLAR ASSEMBLY
21	4416055001		LOCKUP COLLAR
22	1900156008		SPRING
23	4406089002		LOCKUP HUB
24	1900139050		SNAP RING

BW4416 STYLE (cont.)

ILL #	MIDWEST #	REF #	REPLACEMENT PART DESCRIPTION
25	1900193035		THRUST WASHER (2 REQ.)
26	1900132009		THRUST BEARING
27	4416644001	2L1Z7177AA	DRIVE SPROCKET ASSEMBLY (w/ BUSHING)
28	4416625001	2L1Z7C108AA	CLUTCH PACK ASSEMBLY (TAG #'S: 4416-002 THRU 12)
	4416625002		CLUTCH PACK ASSEMBLY (TAG #'S: 4416-013, 14)
29	4400248001		INSULATOR WASHER
30	4416147001		ARMATURE
31	1900139055		SNAP RING
32	1900156006		WAVE SPRING
33	4400099001		APPLY CAM
34	1900109002		APPLY CAM BALL (3 REQ.)
35	4400712001		COIL HOUSING ASSEMBLY
36	1900132008		THRUST BEARING
37	1300139027		SNAP RING
38	1300052003		PLUG (2 REQ.)
39	4416539001		REAR CASE HALF ASSEMBLY (TAG #'S: 4416-002)
	4416539003		REAR CASE HALF ASSEMBLY (TAG #'S: 4416-004 THRU 14)
40	4416039001		REAR CASE HALF (TAG #'S: 4416-002)
	4416039003		REAR CASE HALF (TAG #'S: 4416-004 THRU 14)
41	1900130021		REAR OUTPUT BEARING
42	1900130006		BALL BEARING
43	4400645017		COIL
44	1300149002		NUT (3 REQ.)
45	1900047004		WASHER (3 REQ.)
46	1300044001		SHIFT SHAFT OIL SEAL
47	1900191023		CAP
48	1900072005		BREATHER BARB
49	1900146007		STUD (2 REQ.)
50	1900183002		HEX HEAD SCREW (METRIC)
51	1000012002		MAGNET
52	1900139054		SNAP RING
53	4406144001		SPROCKET (DRIVEN)
54	HV053	4400143016	CHAIN (1.25")
55	4416179001		INNER LOCKUP HUB
56			TAG
57	1900183036		BOLT (20 REQ.) (TAG #'S: 4416-002 THRU 8)
	1900183034		BOLT (20 REQ.) (TAG #'S: 4416-009 THRU 14)
58	1900016004		SEALING RING
59	1900044013	G169	REAR OUTPUT SEAL
60	1900191017		SHIPPING PLUG
61	4416648002		SHIFT MOTOR (TAG #'S: 4416-002 THRU 12)
	4416648004		SHIFT MOTOR (TAG #'S: 4416-013, 14)
62	4416185001		BRACKET (TAG #'S: 4416-002, 4)
	4416185002		BRACKET (TAG #'S: 4416-005 THRU 12)
	4416185003		BRACKET (TAG #'S: 4416-0013, 14)
63	1900183012		BOLT (3 REQ.)
64	4400156001	F1TZ7219A	SHIFT FORK SPRING
65	4416671002	2L1Z7061BA	FRONT OUTPUT SHAFT ASSEMBLY (w/ SHIELD)
66	4406622002		SHIFT CAM ASSEMBLY (TAG #: 4416-002)
	4416622001		SHIFT CAM ASSEMBLY (TAG #'S: 4416-004 THRU 14)
67	4406122002		SHIFT CAM SHAFT (TAG #'S: 4416-004 THRU 14)
	4406122003		SHIFT CAM SHAFT (TAG #'S: 4416-002)
68	1356156006		TORSION SPRING
69	1356053005		SHIFT CAM SPACER (SITS INSIDE OF TORSION SPRING)
70	4406099004		SHIFT CAM
71	4406596005	XL3Z7289AA	REDUCTION FORK ASSEMBLY (w/ ROLLER, PIN & PADS)
72	1356235001	E9TZ7C430A	FORK PAD FOR REDUCTION FORK (2 REQ.)
73	4406096009		REDUCTION FORK
74	1900043009		PIN
75	1352127001		ROLLER
76	4406100001	F65Z7240BA	FORK RAIL
77	4416096001	2L1Z7289BA	SHIFT FORK

KITS

T4416R	→ BEARING, SEAL & GASKET KIT
K4416	→ GASKET & SEAL KIT

DANA® 28 STYLE

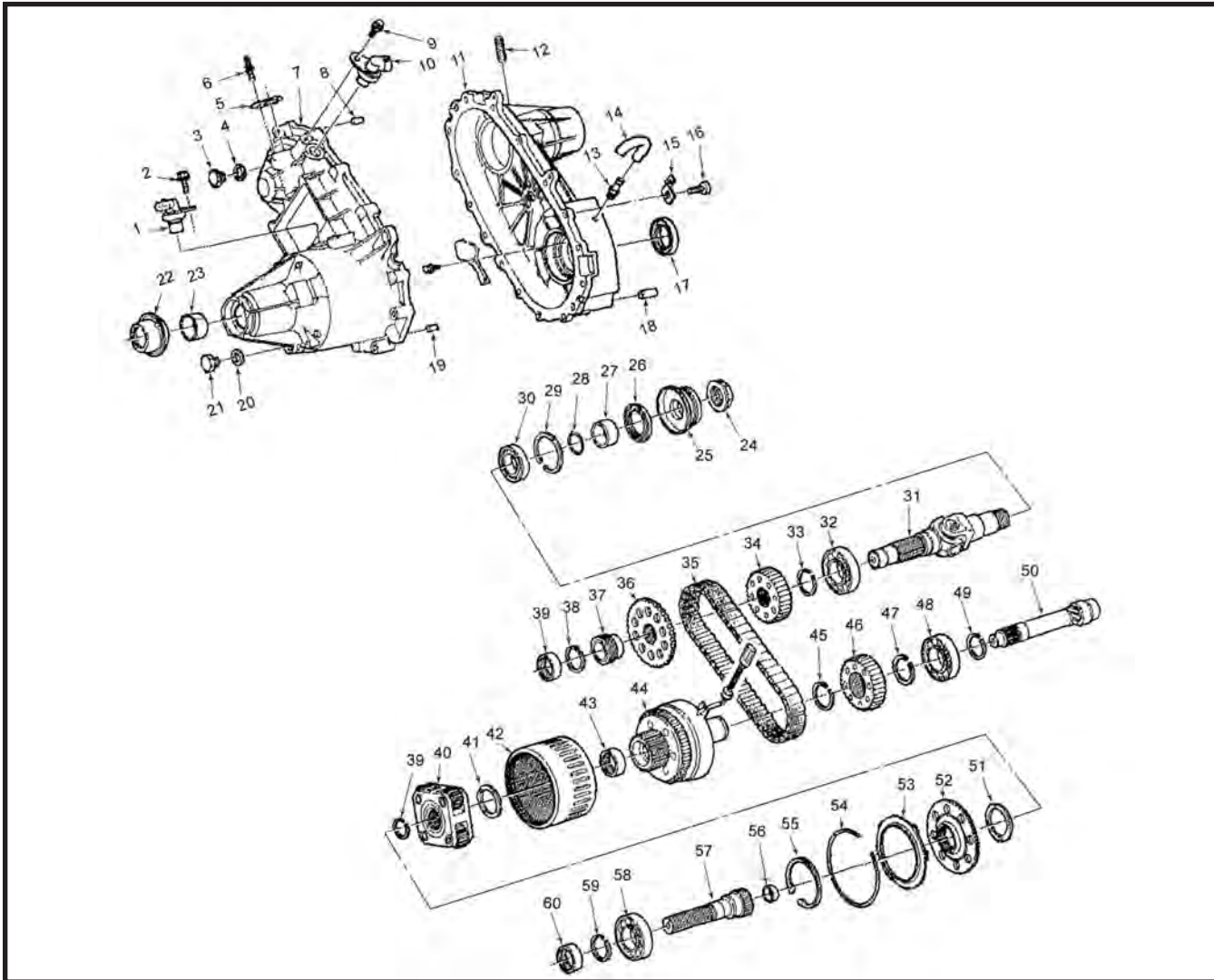

ILL #	MIDWEST #	REF #	REPLACEMENT PART DESCRIPTION
17	710389		DANA 28 INPUT SEAL
22	1900044013		DANA 28 REAR SEAL
23	W50-62		DANA 28 TAILHOUSING BUSHING
25	710388		DANA 28 FRONT OUTPUT SEAL
28	AS029		DANA 28 FRONT OUTPUT O-RING
30	108		DANA 28 FRONT OUTPUT BEARING
32	209		DANA 28 FRONT OUTPUT BEARING
35	HV048		DANA 28 CHAIN
39	B2110		DANA 28 FRONT OUTPUT SHAFT REAR BEARING
43	B2110		DANA 28 INPUT SHAFT REAR NEEDLE BEARING
48	209		DANA 28 INPUT BEARING
58	209		DANA 28 REAR OUTPUT BEARING
60	B2110		DANA 28 REAR OUTPUT SHAFT REAR BEARING
	50BG0751		DANA 28 CLUTCH BEARING
N.I.	76569X		NEW UNIT - COMPLETE

KITS

TC28R	→ BEARING, SEAL & GASKET KIT
K28	→ GASKET & SEAL KIT

NV271 / 273 STYLE

FORD® F250/350, 1999-UP

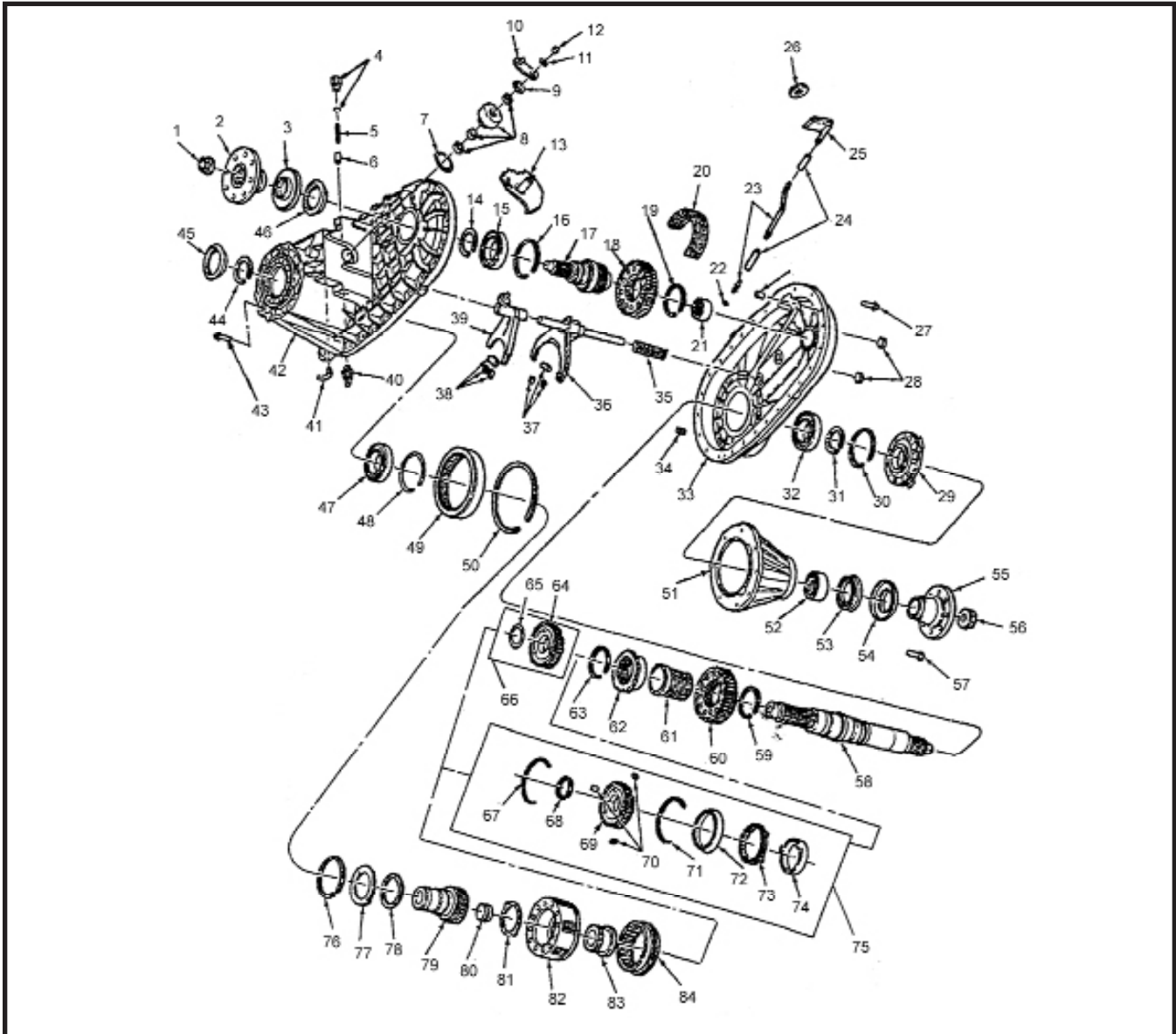

ILL #	MIDWEST #	REF #	REPLACEMENT PART DESCRIPTION
1	NV25441		NUT - OUTPUT FLANGE
2	NV25442	F81Z7B214BA	FLANGE ASSY - OUTPUT
3		F81Z7118BA	SLINGER - FLANGE ASSY
N.I.	NV25439	F81Z7085AA	RETAINER ASSY - REAR EXTENSION
4	F81Z7288AA		O-RING - POPPET SCREW
4	NV16756	F81Z7L013AA	SCREW - POPPET SPRING
5	NV17071	F81Z7219AA	SPRING - POPPET PLUNGER
6	NV16754	F81Z7233AA	POPPET PLUNGER
7	NV13725	F81Z7Z119AA	O-RING - SECTOR SHIFT SHAFT
8	NV24316	2C3Z7E321AA	SUPPORT - SECTOR SHAFT
9	NV25370	F81Z7A148AA	SPACER - LEVER
10	NV24302	F81Z7B106AA	LEVER ASSY - SHIFT
11	2436163		WASHER - SHIFT LEVER
12	NV13992	F81Z7Z114AA	NUT - SHIFT LEVER TO SHAFT
13	NV26060	F81Z7F063AA	SECTOR ASSY - 271 - (MECH. SHIFT)
13	NV26062	F81Z7F063BA	SECTOR ASSY - 273 - (ELEC. SHIFT)
14	F81Z7917BA		SNAP RING - FRONT OUTPUT
15	6011	F81Z7025BA	BEARING - FRONT OUTPUT
16	F81Z7049AA		SNAP RING - FRONT OUTPUT

NV271 / NV273 STYLE (cont.)

ILL #	MIDWEST #	REF #	REPLACEMENT PART DESCRIPTION
17	NV24272	F81Z7061BA	FRONT OUTPUT SHAFT
18	NV21966	F81Z7177AA	SPROCKET - CHAIN DRIVE/DRIVEN
19	F81Z7917BA		SNAP RING - FRONT OUTPUT REAR
20	HV064	F81Z7A029AA	CHAIN - TRANSFER CASE DRIVE - 1-1/2" WIDE
21	SCE2416	F81Z7127AA	BEARING - FRONT OUTPUT REAR
22	NV16214	F81Z7288AA	O-RING - PUMP PICKUP
23	NV25680	F81Z7A210AA	OIL TUBE - PICKUP
23	NV25681	F81Z7A210BA	OIL TUBE - PICKUP
24	NV16218	F81Z7N148AA	CONNECTOR - OIL TUBE
25	NV16217	F81Z7A098AB	SCREEN - OIL PICKUP
26	NV95472	E0TZ7E290A	MAGNET
27	6101526		BOLT - HEX HEAD - CASE
28	NV22398	F81Z7A010AA	PLUG - FILL/DRAIN
29	NV25519	F81Z7A149AA	OIL PUMP ASSY
30	F81Z7R141AA		SNAP RING - MAIN SHAFT REAR BEARING
32	212	F81Z7015AA	BEARING - MAIN SHAFT REAR
33	NV24276	F81Z7005BA	CASE ASSY - REAR HALF
34			DOWEL - CASE ALIGNMENT
35	F81Z7219BA		SPRING - MODE SHIFT SHAFT
36	NV24262	F81Z7289AA	SHIFT FORK - MODE - ALL
37	4167969	F81Z7C430AA	FORK PAD (2 REQ.)
37	4219073	F81Z7C340BA	FORK PAD - CENTER
37	NV37284		UPDATED PADS
38	4338376		FORK PAD - CENTER
38	NV17207	F81Z7C430AA	FORK PAD - 273 ENDS
38	NV25402	F81Z7C430EA	FORK PAD - 273 CENTER
39	NV41819	C41876	SHIFT FORK - RANGE - ALUMINUM
39	4746134	F81Z7289DA	SHIFT FORK - RANGE - 271 LATE
39	NV17896	F81Z7289BA	SHIFT FORK - RANGE - 273 EARLY
39	NV27885	1C3Z7A082BA	SHIFT FORK - RANGE - 273 LATE
39	NV41113		SHIFT FORK - RANGE - 271 (UPDATED w/ PADS)
40	NV24295		SWITCH
41	NV17988		VENT - FRONT CASE
42	NV26962	F81Z7005AA	CASE ASSY - FRONT HALF 271 - (MECH. SHIFT)
42	NV24247	F81Z7005CA	CASE ASSY - FRONT HALF 273 - (ELEC. SHIFT)
43			STUD - TRANSFER CASE MOUNTING
44	F81Z7079AA	F81Z7079AA	SNAP RING - INPUT
45	NV25626	F81Z7B215AA	SEAL - INPUT
46	NV24288	F81Z7B215BA	SEAL - FRONT OUTPUT
47	211		BEARING - INPUT
48	F81Z7079AA		SNAP RING - INPUT
49	N.S.S.		ANNULUS RING GEAR - MUST PURCHASE FRONT CASE ASSY
50	F81Z7917AA		SNAP RING - ANNULUS RETAINING
51	F81Z7085AA		EXTENSION HOUSING
52	B3416	F81Z7118BA	NEEDLE BEARING - REAR OUTPUT
53	NV24288	F81Z7B215BA	SEAL - REAR OUTPUT
54	F81Z7118BB		SLINGER - OUTPUT FLANGE
55	NV25442	F81Z7B214AA	FLANGE - OUTPUT
56	NV25441		NUT - OUTPUT FLANGE
57			SCREW - REAR RETAINER
58	NV42757	F81Z7061BA	MAIN SHAFT - EARLY
58	NP43218K		MAIN SHAFT KIT - 271 (INCLUDES MAIN SHAFT, RANGE FORK, RANGE SLIDER) - UPDATED
58	NP43219K		MAIN SHAFT KIT - 273 (INCLUDES MAIN SHAFT, RANGE FORK, RANGE SLIDER) - UPDATED
59	F81Z7064BA		SNAP RING - DRIVE SPROCKET
60	NV21966	F81Z7177AA	SPROCKET - CHAIN DRIVE/DRIVEN
61	NV25552	F81Z7W060BA	HUB - DRIVE SPROCKET
62	NV25524	F81Z7C215AA	CLUTCH GEAR - MODE SHIFT
63	F81Z7064BA		SNAP RING - CLUTCH GEAR
64	NV31098	F81Z7124AA	HUB - MODE SHIFT
65	F81Z7064AA		SNAP RING - SHIFT HUB
67	NP208K		SYNCHRONIZER KEY & SPRING KIT
68	YC3Z7107FA		SNAP RING - SYNCHRO HUB
69	NV28526		SYNCHRONIZER ASSY - 273
69	F81Z7183AA		SYNCHRO SLEEVE

NV271 / NV273 STYLE (cont.)

ILL #	MIDWEST #	REF #	REPLACEMENT PART DESCRIPTION
69	F81Z7124MA		SYNCHRO HUB
70/71	NP208K		SYNCHRONIZER KEY & SPRING KIT
72	NV30131	YC3Z7107FA	SYNCHRO RING - BLOCKER
73	NV30130	YC3Z7K317AA	SYNCHRONIZER RING - CENTER
74	NV26549	F81Z7018AA	SYNCHRO RING
76	F81Z7R516AA		SNAP RING
77	F81Z7B066CA		LOCK PLATE - INPUT, PLANETARY
78	F81Z7Z118AA		THRUST WASHER - INPUT
79	NV26605	F81Z7017BA	INPUT w/6 SPEED (7.3L) (24T)
79	NV44631		INPUT w/ ZF 6 SPEED (6 LITER DIESEL) 34T
79	NV24257	F81Z7017AA	INPUT - (31T) w/4 SPEED AUTOMATIC / 5 SPEED ZF
80	NV24260	F81Z7120AA	POCKET BEARING - INPUT NEEDLE
81	F81Z7Z213AA		THRUST WASHER - INPUT
82	NV17869	F81Z7A398AA	PLANETARY ASSY
83	NV26948	F81Z7100AA	RANGE SLEEVE - EARLY
83	NV38307		RANGE SLEEVE - LATE
84	NV17823	F81Z7183AA	SLEEVE - MODE SHIFT
N.I.	YC3Z7G360AA		SHIFT MOTOR - 273 - (ELEC. SHIFT)

KITS

T485R	→	BEARING, GASKET & SEAL KIT
K271	→	GASKET & SEAL KIT
NP208K	→	SYNCHRO SPRINGS AND KEY KIT
NP43218K	→	MAIN SHAFT KIT - 271 (INCLUDES MAIN SHAFT, RANGE FORK, RANGE SLIDER) - UPDATED
NP43219K	→	MAIN SHAFT KIT - 273 (INCLUDES MAIN SHAFT, RANGE FORK, RANGE SLIDER) - UPDATED



**Motive
Gear®**

TRANSFER CASE KITS

REFERENCE GUIDE

BW1345 STYLE

T1345R	BEARING KIT (INCLUDES BEARING, SEALS & GASKET
K1345	GASKET & SEAL KIT
SP1345-50	SMALL PARTS KIT

BW1350 STYLE

T1350R	BEARING, SEAL & GASKET KIT
SP1350-50	SMALL PARTS KIT
K1350	GASKET & SEAL KIT

BW1354 STYLE

T1354R	BEARING GASKET & SEAL KIT
K1354	GASKET & SEAL KIT
TC2050	ADAPTER GASKET TO TRANS

BW1356 STYLE

T1356R	BEARING, SEAL & GASKET KIT
K1356	GASKET & SEAL KIT
SP1356-50	SMALL PARTS KIT
PK1356	OIL PUMP KIT

BW1370 STYLE

T1370R	BEARING KIT
SP1370-50	SMALL PARTS KIT
K1370	GASKET & SEAL KIT
PK1356	PUMP KIT

BW4404 STYLE

T4404R	BEARING KIT
K4404	GASKET & SEAL KIT

BW4405 STYLE

T4405R	BEARING GASKET & SEAL KIT
K4405	GASKET & SEAL KIT

BW4406 STYLE

T4406R	BEARING GASKET & SEAL KIT
K4406	GASKET & SEAL KIT

TRANSFER CASE KITS *REFERENCE GUIDE (cont.)*

BW4407 STYLE

T4407R K4407	BEARING, GASKET & SEAL KIT GASKET & SEAL KIT
-----------------	---

BW4410 STYLE

T4410R K4410	BEARING, SEAL & GASKET KIT GASKET & SEAL KIT
-----------------	---

BW4411 STYLE

T4411R K4411	BEARING, SEAL & GASKET KIT GASKET & SEAL KIT
-----------------	---

BW4416 STYLE

T4416R K4416	BEARING, SEAL & GASKET KIT GASKET & SEAL KIT
-----------------	---

BW4470 STYLE

T4470R SP4470-50 K4470	BEARING KIT SMALL PARTS KIT GASKET & SEAL KIT
------------------------------	---

BW4472 STYLE

T1372R K1372	BEARING, GASKET & SEAL KIT GASKET & SEAL KIT
-----------------	---

DANA® 28 STYLE

TC28R K28	BEARING, SEAL & GASKET KIT GASKET & SEAL KIT
--------------	---

NP203 STYLE

T203R SP203-50 GS203-55 K203 K203A 13624 501 501M 502 502M	BEARING, GASKET & SEAL KIT SMALL PARTS KIT GASKET SET GASKET & SEAL KIT GASKET & SEAL KIT - FORD® CHAIN AND SPROCKET KIT (2" CHAIN) PART TIME KIT - SUPERWINCH® PART TIME KIT - MILE MARKER 501 KIT - 9790R HUBS 501M KIT - 9790R HUBS
---	---

TRANSFER CASE KITS REFERENCE GUIDE (cont.)

NP205 STYLE

T172R	BEARING, GASKET & SEAL KIT - 1307L INPUT BRG.
T172RHD	BEARING, GASKET & SEAL KIT - 1210L INPUT BRG.
SPTC205-50	SMALL PARTS KIT
GS205-55	GASKET SET
K205	GASKET & SEAL KIT FORD* - DODGE* & GM*
6259656R	COUPLER - GM 10 SPL. 4-1/4" O.A.
6273964R	COUPLER - GM 27 SPL.
4505302	COUPLER - DODGE 29 SPL.

NP208 STYLE

T212R	BEARING SEAL & GASKET KIT
SP208-50	SMALL PARTS KIT
K208	GASKET/SEAL KIT

NP219 STYLE

T229R	BEARINGS, GASKETS, SEALS
K208	GASKET & SEAL KIT

NV136 STYLE

TC136R	BEARING, GASKET & SEAL KIT
K136	GASKET & SEAL KIT

NV228 STYLE

T229R	BEARING KIT
SP208-50	SMALL PARTS KIT
K208	GASKETS, SEALS, O-RING
12442	ASSEMBLY, 229

NV231/233 STYLE

T230R	BEARING SEAL AND GASKET KIT - W/6010N INPUT BEARING
T230RA	BEARING, SEAL AND GASKET KIT - W/BD50-8 INPUT BEARING
T231R	BEARING, GASKET AND SEAL KIT
T231RL	BEARING, GASKET AND SEAL KIT - LATE (110L INPUT BEARING)
15866	FORK PAD KIT
K231	GASKET & SEAL KIT
SP231-50	SMALL PARTS KIT

NV236 - NV246 STYLE

TC136R	BEARING, GASKET & SEAL KIT 236
T351R	BEARING, GASKET & SEAL KIT 246
K236	GASKET & SEAL KIT 236
K246	GASKET & SEAL KIT 246

NV241 STYLE

T241R	BEARING, GASKET & SEAL KIT TO 1994
T241RL	BEARING, GASKET & SEAL KIT 1995-ON
T241RHD	BEARING, GASKET & SEAL KIT - DODGE HD
K241	GASKET & SEAL KIT

TRANSFER CASE KITS REFERENCE GUIDE (cont.)

NV242J/DHD STYLE

T242R	BEARING, GASKET & SEAL KIT - EARLY JEEP TO 1994
T242RL	BEARING, GASKET & SEAL KIT - LATE JEEP 1994-ON -110L INPUT BEARING
T242RHD	BEARING, GASKET & SEAL KIT - DODGE*
K242	GASKET & SEAL KIT - EARLY JEEP TO 1994
K242A	GASKET & SEAL KIT - DODGE
K242B	GASKET & SEAL KIT - LATE JEEP 1994-ON
SP242-50B	SMALL PARTS KIT

NV243 STYLE

T243R	BEARING, GASKET & SEAL KIT
K243	GASKET & SEAL KIT
SP243-50	SMALL PARTS KIT

NV247/249J STYLE

T249R	BEARING, SEAL & GASKET KIT
T249RHD	BEARING, SEAL & GASKET KIT - HEAVY DUTY
T249RL	BEARING, SEAL & GASKET KIT - LATE
K249	GASKET & SEAL KIT
K243	GASKET & SEAL KIT
SP243-50	SMALL PARTS KIT

NV261/263 (LD) STYLE

T371R	BEARING, SEAL & GASKET KIT
K261HD	GASKET & SEAL KIT

NV261/263 (HD) STYLE

T371R	BEARING, SEAL & GASKET KIT
K261HD	GASKET & SEAL KIT

NV261/263 (XHD) STYLE

T371RA	BEARING, SEAL & GASKET KIT
K261XHD	GASKET & SEAL KIT

NV271/273 STYLE

T485R	BEARING, GASKET & SEAL KIT
K271	GASKET & SEAL KIT
NP208K	SYNCHRO SPRINGS AND KEY KIT
NP43218K	MAIN SHAFT KIT - 271 (INCLUDES MAIN SHAFT, RANGE FORK, RANGE SLIDER) - UPDATED
NP43219K	MAIN SHAFT KIT - 273 (INCLUDES MAIN SHAFT, RANGE FORK, RANGE SLIDER) - UPDATED

Midwest Truck & Auto Parts, Inc. gathered this transfer case chain information from what we believe to be reliable sources. We cannot guarantee the accuracy of this information, and we are not liable for any damages to any unit because of this information being used.

NEW PROCESS® / NEW VENTURE® STYLE TRANSFER CASE CHAINS

CASE MODEL	REF MFG	NOTES	MOTIVE GEAR® #	MORSE® PART #	CLOYES® PART #	NOMINAL CHAIN DIMENSIONS
119	Chrysler® Jeep	80-88 Jeep	8130831	HV-015	10-015C	3/8 Pitch x 1-3/4 W x 98 Pitches-RJ
129	Chrysler Jeep*	80-88 Jeep	8130831	HV-015	10-015C	3/8 Pitch x 1-3/4 W x 98 Pitches-RJ
149	GM	Full Time full size truck, Silverado, SS & GMC Sierra Denali		HV-072		.375 Pitch x 1-1/4 W x 98 Pitches - RJ
203	Chrys/Ford/GM*	73-78	11428	HV-005	10-005C	3/8 Pitch x 2-1/2 W x 98 Pitches-RJ
203	Chrys/Ford/GM	78-79	13433	HV-009	10-009C	1/2 Pitch x 2 W x 72 Pitches-RJ
207	Chrysler	84-88 Jeep	1350143001	HV-022	10-022C	1/2 Pitch x 1-1/4 W x 62 Pitches-RP
208	Chrysler Jeep	80-88 Jeep	4167995	HV-014 (RJ)/ HV-025 (RP)	10-014C	1/2 Pitch x 1-1/4 W x 72 Pitches
208	Ford*	80-88	13797	HV-012	10-012C	1/2 Pitch x 1-1/4 W x 84 Pitches-RP
218	GM/AM General	86-99 (Hummer)		HV-026		1/2 Pitch x 1-1/2 W x 72 Pitches-RP
219	Chrysler Jeep	80-90 Jeep	8130831	HV-015	10-015C	3/8 Pitch x 1-3/4 W x 98 Pitches-RJ
226/126	GM	Active on Demand, GM 360, 370 Envoy and Trailblazer		HV-059		.375 Pitch x 1-1/4 W x 86 Pitches - RJ
228	Chrysler Jeep	80-90 Jeep	8130831	HV-015	10-015C	3/8 Pitch x 1-3/4 W x 98 Pitches-RJ
229	Chrysler Jeep	80-90 Jeep	8130832	HV-016	10-015C	3/8 Pitch x 1-3/4 W x 98 Pitches-RJ
231A	Chrysler Jeep	89-ON Jeep	4338935	HV-027	10-027C	1/2 Pitch x 1 W x 62 Pitches-RP
231C/233C	GM	W2.8L 89-ON	4338935	HV-027	10-027C	1/2 Pitch x 1 W x 62 Pitches-RP
231C/233C	GM	W4.3L 89-98	1350143001	HV-022	10-022C	1/2 Pitch x 1-1/4 W x 62 Pitches-RP
231D	Chrysler	89-ON	4338935	HV-027	10-027C	1/2 Pitch x 1 W x 62 Pitches-RP
233 Electric	Chrysler Jeep	95-ON Jeep	4338935	HV-027	10-027C	1/2 Pitch x 1 W x 62 Pitches-RP
231/233 HD	GM	T Truck S10	1350143001	HV-022	10-022C	1/2 Pitch x 1-1/4 W x 62 Pitches-RP
236/136	GM	98-ON Blazer, Bravada & Astro Van		HV-062		3/8 Pitch x 1 W x 98 Pitches-RJ
241	Jeep*	Part Time Jeep Rubicon		HV-081		.4346 Pitch x 1-1/4 W x 84 Pitches -RJ
241C/243C	Chrysler/GM	GM 89-98, 243 Electric Shift Dodge* Full 93-98	4167995	HV-025		1/2 Pitch x 1-1/4 W x 72 Pitches-RP
241G2	Dodge*	Part Time Electric Shift, Ram 1500, Standard 2002 - May 2004		HV081		.4346 Pitch x 1-1/4 W x 84 Pitches -RJ
241G2	Dodge	Part Time Electric Shift, Ram 1500, Standard June 2004 & UP		HV-072		
241HD	Chrysler	Dodge 90-99		HV-031		1/2 Pitch x 1-1/2 W x 72 Pitches-RP
242/244	Chrysler Jeep	89-2000 Jeep	83504575	HV-028	10-028C	1/2 Pitch x 1 W x 72 Pitches-RP
242	Chrysler	Durango, Dakota and Jeep - 5.2L and 5.9L Engines 98-01		HV-063		3/8 Pitch x 1-1/4 W x 98 Pitches-RJ
242ECE	Chrysler Jeep	Jeep Europe XJ & ZJ		HV-061		.5033 Pitch x 1 W x 72 Pitches-RJ
242H	GM/AM General	AMG Hummer		HV-060		.5033 Pitch x 1-1/4 W x 72 Pitches-RJ
242KJ	Jeep*	Jeep Liberty Select Trac		HV-062		3/8 Pitch x 1 W x 98 Pitches-RJ
243G2	Dodge*	Part Time Electric Shift, Ram 1500, 2002 - May 2004		HV-081		.4346 Pitch x 1-1/4 W x 84 Pitches-RJ
243G2	Dodge*	Part Time Electric Shift, Ram 1500 Optional All 4WD - June 2004 & UP		HV-072		.375 Pitch x 1-1/4 W x 98 Pitches-RJ

RJ = Rocket Joint Pin

RP - Round

NEW PROCESS® / NEW VENTURE® STYLE TRANSFER CASE CHAINS (cont.)

CASE MODEL	REF MFG	NOTES	MOTIVE GEAR® #	MORSE® PART #	CLOYES® PART #	NOMINAL CHAIN DIMENSIONS
244DR (Heavy)	Dodge	2004 Dodge Dakota w/ 4.7L and 5.9L on Quad Cab		HV-072		.375 Pitch x 1-1/4 W x 98 Pitches-RJ
244HB	Dodge	Dodge Durango Gemini System, 2004 & UP		TK006		Two Sprockets (HS014) and Two Chains (HV084)
244HB	Dodge	Chains (2)		HV-084		.375 Pitch x .625 W x 98 Pitches-RJ
246	GM*	99 SUV Only, One Blue Guide Link		HV-063		3/8 Pitch x 1-1/4 W x 98 Pitches-RJ
246	GM	99-ON GMT 800, 2000-ON - Full Size SUV (3 Blue Guide Links)		HV-072		3/8 Pitch x 1-1/4 W x 98 Pitches-RJ
247	Chrysler Jeep*	99 Jeep Grd Cherokee		HV-071		3/8 Pitch x 1 W x 98 Pitches-RJ
249	Chrysler* Jeep	92-95 Jeep		HV-034		3/8 Pitch x 1-1/4 W x 98 Pitches-RJ
261/263	GM Full Time	GMT 800 (3 Blue Guide Links) 99+		HV-072		3/8 Pitch x 1-1/4 W x 98 Pitches-RJ
261HD/263HD	GM Part Time	GMT 800 Full Size K Truck		HV-069		3/8 Pitch x 1-1/2 W x 98 Pitches-RJ
261SHD	Chrysler D/C	2001-Current		HV-074		.4346 Pitch x 1-1/2 W x 84 Pitches

RJ = Rocket Joint Pin

RP - Round

Midwest Truck & Auto Parts, Inc. gathered this transfer case chain information from what we believe to be reliable sources. We cannot guarantee the accuracy of this information, and we are not liable for any damages to any unit because of this information being used.

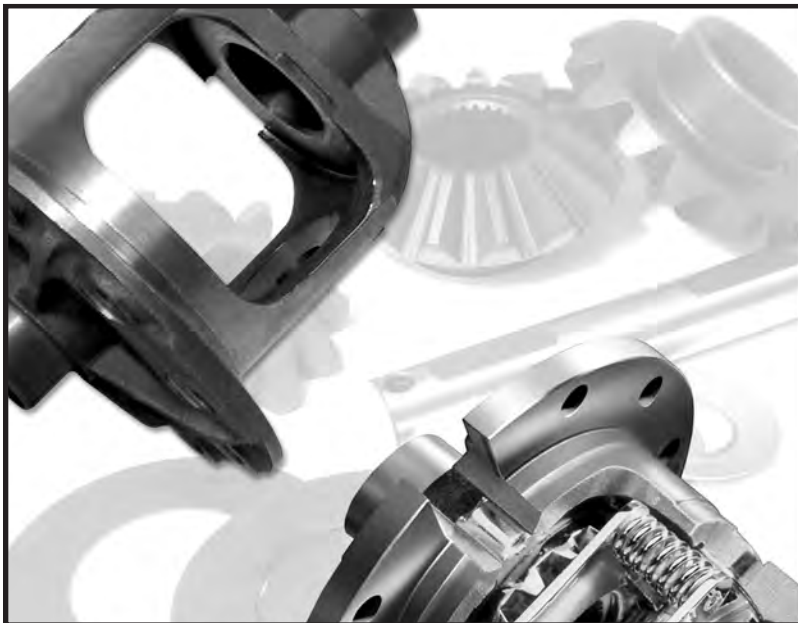

Cases and internal kits supplied by Motive Gear are available both empty or loaded, for open and posi applications.

- ▶ Easy installation
- ▶ Unmatched durability
- ▶ Comprehensive warranty

BORG WARNER® STYLE TRANSFER CASE CHAINS

CASE MODEL	REF MFG	NOTES	MOTIVE GEAR® #	MORSE® PART #	CLOYES® PART #	NOMINAL CHAIN DIMENSIONS
1305	Chrysler Jeep®	73-79 Jeep®	8122392	HV-007	10-007C	3/8 Pitch x 2-1/2 W x 96 Pitches-RJ
1345	Chrysler Jeep®	CJ7 - Auto Overdrive		HV-007X		3/8 Pitch x 2-1/2 W x 92 Pitches-RJ
1345	Ford®	Fd 80-82, 150, 250,350	1345143001	HV-013	10-013C	1/2 Pitch x 1-1/2 W x 86 Pitches-RJ
1350	Ford, Chrysler®	Fd 80-83, Jeep® 84-88	1350143001	HV-022	10-022C	1/2 Pitch x 1-1/4 W x 62 Pitches-RP
1354	Ford®	Fd 90-ON	1350143001	HV-022	10-022C	1/2 Pitch x 1-1/4 W x 62 Pitches-RP
1356	Ford®	Fd 80-96 F Series/ Bronco	13797	HV-012	10-012C	1/2 Pitch x 1-1/4 W x 84 Pitches-RP
1361	Range Rover®	Range Rover® 88-96		HV-049		.5033 Pitch x 2 W x 74 Pitches-RJ Spring Link
1370	GM®	80-ON Full Size Truck	4167995	HV-025		1/2 Pitch x 1-1/4 x 72 Pitches-RP
1372	GM®	90-95 L Van All WD - Straight Pitch	4472143001	HV-032		3/8 Pitch x 1-3/4 W x 86 Pitches-RJ Note: 2 Blue Links & Rounded Link Backs
1372	GM®	90-97 S Blazer Trk/ Bravada/Cyclone/ Typhoon - Random Pitch	1372143001	HV-033		3/8 Pitch x 1-3/4 W x 86 Pitches-RJ Note: 1 Blue Link & Combination Round/Square Link Backs
4401	GM®	GMC® 3500	4167995	HV-025		1/2 Pitch x 1-1/4 W x 72 Pitches-RP Block Lace
4402	Hyundai®	A1 Van, Galloper	4338935	HV-027	10-027C	1/2 Pitch x 1 W x 62 Pitches-RP
4404	Ford®	Explorer/Mountaineer To 97		HV-051		.4346 Pitch x 1-1/4 W x 74 Pitches-RJ
4404 - 5 Liter	Ford®	Explorer/Mountaineer - 5 Liter Engines		HV-070		.4346 Pitch x 1-1/4 W x 74 Pitches-RJ
4405	Ford®	Explorer to 97		HV-051		.4346 Pitch x 1-1/4 W x 74 Pitches-RJ
4405	Ford®	Explorer 9/98-ON (Width Chg) TOD		HV-067		.4346 Pitch x 1 W x 74 Pitches-RJ
4406	Ford®	F150/250 Man & Electronic Shift 96-4/98		HV-052		.4346 Pitch x 1-1/4 W x 86 Pitches-RP
4406	Ford®	May 98-ON F150/250 LD, F150 Manual Shift Width Chg 5.98		HV-066		.4346 Pitch x 1 W x 86 Pitches-RP
4406 TOD	Ford®	F250 96-ON, Expedition and Navigator 99+		HV-053		.4346 Pitch x 1-1/4 W x 86 Pitches-RJ
4407	Ford®	F350/F250 HD		HV-054		.5033 Pitch x 1-1/2 W x 84 Pitches-RP
4408	Daewoo®	Previously Sang Yung	1350143001	HV-022		1/2 Pitch x 1-1/4 W x 62 Pitches-RP
4409	Mercedes®	Mercedes® 97-ON		HV-055		.4346 Pitch x 1-1/2 W x 70 Pitches-RJ
4410	Ford®	Explorer 5.0L 2001		HV-078		.4346 Pitch x 1-1/4 W x 74 Pitches-RJ
4411	Ford®	Explorer 4.0L 2001		HV-067		.4346 Pitch x 1 W x 74 Pitches-RJ
4411 TOD	Ford®	2002 Aviator, Mountaineer		HV-067		.4346 Pitch x 1 W x 74 Pitches-RJ
4416 TOD	Ford®	Expedition, Navigator 2001		HV-053		.4346 Pitch x 1-1/4 W x 86 Pitches-RJ
4422	Isuzu®	Isuzu® 95-ON		HV-056		.4346 Pitch x 1-1/4 W x 70 Pitches-RJ
4423/4421	Sang Yung®	Sport Utility Vehicle - Sang Yung 4400143015		HV-051		.4346 Pitch x 1-1/4 W x 74 Pitches-RJ
4424 ESO	Hyundai®	Terracan, Highlander, A1, Kia®, BL 2001 & UP			HV-027	.5033 Pitch x 1 W x 62 Pitches -RP
4424 TOD	Hyundai®	Terracan, Highlander, A1,		HV-070		.4346 Pitch x 1-1/4 W x 74 Pitches-RJ Note: 2 Blue links separ. by one link
4462	Range Rover®	Land Rover® 97-ON		HV-057		.5033 Pitch x 2 W x 80 Pitches-RJ
4470	GM®	Full Size Truck 3500/ K30 90-96		HV-031		1/2 Pitch x 1-1/2 W x 72 Pitches-RP
4472	GM®	90-97 L Van	4472143001	HV-032		3/8 Pitch x 1-3/4 W x 86 Pitches-RP Note: 2 Blue Links & Rounded Link Backs Straight Pitch
4472	GM®	90-97 S10/96 Van Safari	1372143001	HV-033		3/8 Pitch x 1-3/4 W x 86 Pitches-RJ Note: 1 Blue Link & Combination Round/Square Link Backs Random Pitch
4476	GM®	Full Time		HV-076		.4346 Pitch x 1-1/4 W x 84 Pitches-RJ
4476	GM®	Cadillac® SRX 2003 & UP		HV-080		.375 Pitch x 1-1/2 W x 74 Pitches-RJ
4476, 4479	GM®	Cadillac® 265, 295, 2004&UP		HV-095		.375 Pitch x 1-1/2 W x 74 Pitches-RJ

RJ = Rocket Joint
RP = Round Pin

Midwest Truck & Auto Parts, Inc. gathered this transfer case chain information from what we believe to be reliable sources. We cannot guarantee the accuracy of this information, and we are not liable for any damages to any unit because of this information being used.

BORG WARNER® STYLE TRANSFER CASE CHAINS (cont.)

CASE MODEL	REF MFG	NOTES	MOTIVE GEAR® #	MORSE® PART #	CLOYES® PART #	NOMINAL CHAIN DIMENSIONS
4481, 4482	GM	GMT820, LD, Tahoe, Yukon Warrior, Avalanche		HV-076		.4346 Pitch x 1-1/4 W x 84 Pitches-RJ
4482	Hummer/GM	Full Time Hummer 2		HV-077		.4346 Pitch x 1-1/2 W x 84 Pitches-RJ

RJ = Rocket Joint
RP = Round Pin

Midwest Truck & Auto Parts, Inc. gathered this transfer case chain information from what we believe to be reliable sources. We cannot guarantee the accuracy of this information, and we are not liable for any damages to any unit because of this information being used.

MISCELLANEOUS/IMPORT

REF MFG	NOTES	MOTIVE GEAR® #	MORSE® PART #	CLOYES® PART #	NOMINAL CHAIN DIMENSIONS
Austin	Maxi Allegro		HV-008		3/8 Pitch x 1 W x 74 Pitches-RJ
BMW 325 I	4WD Pre-1988		HV-024		3/8 Pitch x 1-3/4 W x 68 Pitches-RJ Straight Pitch (All Rounded Link Backs)
BMW 325 I	4WD 89-89		HV-024R		3/8 Pitch x 1-3/4 W x 68 Pitches-RJ Random Pitch, Rounded & Square Link Backs
Dodge® Ram 50	4WD 80-ON		HV-104		3/8 Pitch x 1-3/4 W x 82 Pitches-RJ
Ford® Aerostar	(Dana® TC28) 90-97		HV-048		3/8 Pitch x 1-1/4 W x 86 Pitches-RP
Geo Tracker	Suzuki Sidekick 88-ON		HV-110		3/8 Pitch x 1 W x 68 Pitches-RP
Isuzu® Trooper	Truck 84-ON		HV-102		1/2 Pitch x 1-1/4 W x 62 Pitches-RP
Mazda®	Van & Pickup 84-ON		HV-105		3/8 Pitch x 1-3/4 W x 80 Pitches-RJ
Mazda	MPV 89-ON		HV-111		7/16 Pitch x 1-1/2 W x 84 Pitches-RJ
Mitsubishi®	Montero (4WD) 80-ON		HV-104		3/8 Pitch x 1-3/4 W x 82 Pitches-RJ
Mitsubishi	Forte, Montero, Montero Sports Nov. 90+		HV-112		7/16 Pitch x 1-1/2 W x 70 Pitches-RJ
Mitsubishi	Forte, Montero, Montero Sports Nov. 90+		HV-113		7/16 Pitch x 1-1/4 W x 68 Pitches-RJ
Mitsubishi	Montero, Montero Sports Jul 93+		HV-114		7/16 Pitch x 1-3/4 W x 70 Pitches-RJ
Mitsubishi	Montero Sports 8/98+		HV-115		3/8 Pitch x 1-1/2 W x 80 Pitches-RJ
Nissan®	Pathfinder/Truck 85-ON		HV-106		3/8 Pitch x 1-3/4 W x 88 Pitches-RJ
Nissan	Pathfinder 7/95-ON		HV-116		7/16 Pitch x 1-1/4 W x 76 Pitches-RJ
Nissan	Van 86-ON		HV-107		3/8 Pitch x 1-1/4 W x 88 Pitches-RJ
Safari	Safari 87-ON		HV-108		3/8 Pitch x 1-7/8 W x 88 Pitches-RP
Scout II, IHC	(4WD) 73-79		HV-006		3/8 Pitch x 2 W x 92 Pitches-RJ
Suzuki®, Chev. Tracker	Suzuki Vitara/Chevy Tracker 8/96-ON		HV-118		3/8 Pitch x 1 W x 68 Pitches-RJ
Toyota®	4-Runner/Truck 84-86		HV-102		1/2 Pitch x 1-1/4 W x 62 Pitches-RP
Toyota	4-Runner/Truck 87-7/88		HV-109B		7/16 Pitch x 1-1/2 W x 74 Pitches-RJ Random Pattern, Springload
Toyota	4-Runner/Truck 87-93		HV-109B		7/16 Pitch x 1-1/2 W x 74 Pitches-RJ Random Pattern, Springload
Toyota	4-Runner, Tacoma 4/93-ON		HV-117		7/16 Pitch x 1-1/4 W x 74 Pitches-RJ Latest Link Profile
Toyota	Van 85-ON		HV-103		1/2 Pitch x 1 W x 62 Pitches -RP

RJ = Rocket Joint
RP - Round Pin

Midwest Truck & Auto Parts, Inc. gathered this transfer case chain information from what we believe to be reliable sources. We cannot guarantee the accuracy of this information, and we are not liable for any damages to any unit because of this information being used.

TRANSFER CASE AND TRANSMISSION FLUID GUIDE

Transfer Case	Fluid	# of Quarts
BW1345	SYNTHETIC ATF PLUS 4	4
BW1350	SYNTHETIC ATF PLUS 4	2
BW1354	SYNTHETIC ATF PLUS 4	2
BW1356	SYNTHETIC ATF PLUS 4	4
BW1370	SYNTHETIC ATF PLUS 4	4
BW4401	SYNTHETIC ATF PLUS 4	4
BW4404	GM® TRANSAXLE 5W-30	2
BW4405	SYNTHETIC ATF PLUS 4	3
BW4406	SYNTHETIC ATF PLUS 4	4
BW4407	SYNTHETIC ATF PLUS 4	5
BW4410	SYNTHETIC ATF PLUS 4	
BW4416	SYNTHETIC ATF PLUS 4	2
BW4472	GM TRANSAXLE 5W-30	3
NV119	GM TRANSAXLE 5W-30	3
NV136	AUTO TRACK II	3
NV149	GM TRANSAXLE 5W-30	3
NP203	GM SYNCHROMESH	5
NP205	GM SYNCHROMESH	3
NV207	GM TRANSAXLE 5W-30	3
NV208	GM TRANSAXLE 5W-30	5
NV219	GM TRANSAXLE 5W-30	3
NV231	GM TRANSAXLE 5W-30	3
NV233	GM TRANSAXLE 5W-30	3
NV241	GM TRANSAXLE 5W-30	3
NV242	GM TRANSAXLE 5W-30	3
NV243	SYNTHETIC ATF PLUS 4	3
NV246	AUTO TRACK II	3
NV247	SYNTHETIC	3
NV249	GM TRANSAXLE 5W-30	3
NV261	GM TRANSAXLE 5W-30	3
NV263	GM TRANSAXLE 5W-30	3
NV271	GM TRANSAXLE 5W-30	5
NV273	GM TRANSAXLE 5W-30	5

Transmission	Fluid	# of Quarts
NV1500	GM SYNCHROMESH	3
NV3500 (HM290) (5LM60)	GM SYNCHROMESH	3
*NV4500	CASTROL SYN TORQUE	5
NV5600	CASTROL SYNCHRO TORQUE	3
ZF S5-42	SYNTHETIC ATF PLUS 4	4
ZF S5-47	SYNTHETIC ATF PLUS 4	4
ZF S6-50	SYNTHETIC ATF PLUS 4	6
AX15	GM SYNCHROMESH	4
AX5	GM SYNCHROMESH	4
BA10	GM SYNCHROMESH	3
FM145	GM SYNCHROMESH	3
FM146	GM SYNCHROMESH	3
*G360	GM SYNCHROMESH	4
M5R1	SYNTHETIC ATF PLUS 4	3
M5R2	SYNTHETIC ATF PLUS 4	4
NISSAN	GM SYNCHROMESH	3
NP535	GM SYNCHROMESH	3
RUG/RTS	GM SYNCHROMESH	3
SM465	GM SYNCHROMESH	5
T18/T19	GM SYNCHROMESH	4
T5	SYNTHETIC ATF PLUS 4	3
T56	SYNTHETIC ATF PLUS 4	5
TOYOTA	GM SYNCHROMESH	3
R150	GM SYNCHROMESH	4

* PLEASE NOTE: IN OUR REBUILT MANUAL TRANSMISSION AND TRANSFER CASE BUYER'S GUIDE, WE LISTED THE NV4500 TRANSMISSION AS SYNCHROMESH, AND THE G360 AS TAKING CASTROL SYN TORQUE. WE HAVE SINCE FOUND THIS INFORMATION TO BE INCORRECT. PLEASE USE THE FLUID INFORMATION LISTED WITHIN THIS CATALOG. TAKING GM



TABLE OF CONTENTS

MOTIVE GEAR® REBUILT TRANSMISSIONS

DODGE®		Page	FORD® (cont.)		Page
4 SPEED			5 SPEED		
NP435 STYLE 4 SPEED	253		TK5 STYLE	5 SPEED	257
			ZF STYLE	5 SPEED	259
5 SPEED			6 SPEED		
AX15 STYLE	5 SPEED	253	ZF6 STYLE	6 SPEED	259
G360 STYLE	5 SPEED	254			
KM145 STYLE 5 SPEED	253				
NP535 STYLE 5 SPEED	253				
NV3500 STYLE 5 SPEED	253				
NV4500 (MT-8) STYLE	5 SPEED	254			
6 SPEED					
NV5600 STYLE 6 SPEED	254				
T56 STYLE	6 SPEED	253			
FORD®					
4 SPEED					
NP435 STYLE	4 SPEED	257			
RTS STYLE	4 SPEED	256			
RUG STYLE	4 SPEED	256			
SROD STYLE	4 SPEED	257			
T18 STYLE	4 SPEED	257			
T19 STYLE	4 SPEED	258			
5 SPEED					
T45 STYLE	5 SPEED	257			
T5 (W/C) STYLE 5 SPEED	257				
T5 (NON- W/C) STYLE	5 SPEED	257			
FM132 STYLE 5 SPEED	258				
FM145 STYLE 5 SPEED	258				
FM146 STYLE 5 SPEED	258				
M5R1 STYLE	5 SPEED	258			
M5R2 STYLE	5 SPEED	259			
(cont.)					
			GMC®		
			4 SPEED		
			SM465 STYLE 4 SPEED	263	
			T4 STYLE	4 SPEED	262
			5 SPEED		
			GETRAG 290 STYLE	5 SPEED	263
			NV1500 STYLE 5 SPEED	263	
			NV4500 STYLE 5 SPEED	263	
			T5 (W/C) STYLE 5 SPEED	262	
			T5 (NON- W/C) STYLE	5 SPEED	262
			6 SPEED		
			T56 STYLE	6 SPEED	263
			JEEP®		
			4 SPEED		
			AX4 STYLE	4 SPEED	268
			SR4 STYLE	4 SPEED	268
			T4 STYLE	4 SPEED	268
			5 SPEED		
			AX5 STYLE	5 SPEED	268
			AX15 STYLE	5 SPEED	269
			BA10 STYLE	5 SPEED	268
			T5 STYLE	5 SPEED	268
			NV3550 STYLE 5 SPEED	269	

REBUILT IMPORT TRANSMISSIONS

ISUZU®			SUZUKI®		
5 SPEED			5 SPEED		
MSG-5ET STYLE 5 SPEED	271		SAMURAI STYLE	5 SPEED	273
MSG-5F STYLE 5 SPEED	271				
NV1500 STYLE 5 SPEED	271				
T5 STYLE	5 SPEED	272			
MAZDA®			TOYOTA®		
5 SPEED			4 SPEED		
B2000 STYLE	5 SPEED	272	L42 STYLE	4 SPEED	273
B2200 STYLE	5 SPEED	272	L43 STYLE	4 SPEED	273
NISSAN®			5 SPEED		
5 SPEED			G52 STYLE	5 SPEED	273
FS5R30 STYLE 5 SPEED	272		L52 STYLE	5 SPEED	273
FS5W71 STYLE 5 SPEED	272		R150 STYLE	5 SPEED	273
			R151 STYLE	5 SPEED	273
			W50 STYLE	5 SPEED	273
			W55 STYLE	5 SPEED	274
			W56 STYLE	5 SPEED	274
			W59 STYLE	5 SPEED	274



TABLE OF CONTENTS

MOTIVE GEAR® REBUILT TRANSFER CASES

DODGE®			Page	GMC®			Page
NP203 STYLE	CAST IRON	254		BW1370 (BW4401) STYLE	ALUMINUM	264	
NP205 STYLE	CAST IRON	254		BW4470 STYLE	ALUMINUM	264	
NP207 STYLE	ALUMINUM	254		BW4472 (BW1372) STYLE	ALUMINUM	264	
NP208 STYLE	ALUMINUM	254		BW4473 STYLE	ALUMINUM	265	
NP231 STYLE	ALUMINUM	255		BW4481 STYLE	ALUMINUM	265	
NP233 STYLE	ALUMINUM	255		NP126 STYLE	ALUMINUM	265	
NP241 STYLE	ALUMINUM	255		NP136 STYLE	ALUMINUM	265	
NP242 STYLE	ALUMINUM	256		NP149 STYLE	ALUMINUM	265	
NP243 STYLE	ALUMINUM	256		NP203 STYLE	CAST IRON	265	
NP244 STYLE	ALUMINUM	256		NP205 STYLE	CAST IRON	265	
NP271 STYLE	ALUMINUM	256		NP207 STYLE	ALUMINUM	266	
NP273 STYLE	ALUMINUM	256		NP208 STYLE	ALUMINUM	266	
				NP226 STYLE	ALUMINUM	266	
				NP231 STYLE	ALUMINUM	266	
				NP233 STYLE	ALUMINUM	266	
				NP236 STYLE	ALUMINUM	267	
				NP241 STYLE	ALUMINUM	267	
				NP243 STYLE	ALUMINUM	267	
				NP246 STYLE	ALUMINUM	267	
				NP261 STYLE	ALUMINUM	267	
				NP263 STYLE	ALUMINUM	268	
FORD®				JEEP®			
BW1345 STYLE	ALUMINUM	260		NP119 STYLE	ALUMINUM	269	
BW1350 STYLE	ALUMINUM	260		NP207 STYLE	ALUMINUM	269	
BW1354 STYLE	ALUMINUM	260		NP208 STYLE	ALUMINUM	269	
BW1356 STYLE	ALUMINUM	260		NP219 STYLE	ALUMINUM	269	
BW4404 STYLE	ALUMINUM	260		NP228 STYLE	ALUMINUM	270	
BW4405 STYLE	ALUMINUM	261		NP229 STYLE	ALUMINUM	270	
BW4406 STYLE	ALUMINUM	261		NP231 STYLE	ALUMINUM	270	
BW4407 STYLE	ALUMINUM	261		NP241 STYLE	ALUMINUM	270	
BW4410 STYLE	ALUMINUM	261		NP242 STYLE	ALUMINUM	270	
BW4411 STYLE	ALUMINUM	261		NP247 STYLE	ALUMINUM	271	
BW4416 STYLE	ALUMINUM	261		NP249 STYLE	ALUMINUM	271	
DANA 28 STYLE	CAST IRON	261		NP251 STYLE	ALUMINUM	271	
NP203 STYLE	CAST IRON	261					
NP205 STYLE	CAST IRON	262					
NP208 STYLE	ALUMINUM	262					
NV271 STYLE	ALUMINUM	262					
NV273 STYLE	ALUMINUM	262					



DODGE® REBUILT TRANSMISSIONS

UNIT

PAGE

PART # NP525 STYLE - 1984-ON FWD CARS

MT-DG-NP525-# CORE - 30 DAYS
MT-DG-NP525-A 5 SPEED FWD 13T PINION, 3.85 RATIO
MT-DG-NP525-B 5 SPEED FWD 15T PINION, 3.87 RATIO
MT-DG-NP525-C 5 SPEED FWD 19T PINION, 3.05 RATIO
MT-DG-NP525-D 5 SPEED FWD 16T PINION, 3.56 RATIO
WHAT WE NEED TO KNOW: YEAR, MAKE, MODEL, PINION RATIO/COUNT

PART # T-56 STYLE - 1993-ON VIPER

MT-DG-T56-# CORE - 30 DAYS
MT-DG-T56-A 6 SPEED W/ CASTING NUMBER OF "1386" RWD
WHAT WE NEED TO KNOW: YEAR, MAKE, MODEL, TAG #

PART # KM145 STYLE - 1983-88 D50

MT-DG-KM145 CORE - 30 DAYS
MT-DG-KM145-1 5 SPEED 4X4 1982-86, 2.0L CABLE CLUTCH
MT-DG-KM145-8 5 SPEED 4X4 1982-ON, 2.6L CABLE CLUTCH
MT-DG-KM145-9 5 SPEED 4X4 1982-ON, 2.6L CABLE CLUTCH
WHAT WE NEED TO KNOW: YEAR, MAKE, MODEL, ENGINE SIZE

PART # AX15 STYLE - 1992-98 DAKOTA

MT-DG-AX15-# CORE - 30 DAYS
MT-DG-AX15-I 5 SPEED 2WD
MT-DG-AX15-J 5 SPEED 4X4
WHAT WE NEED TO KNOW: YEAR, MAKE, MODEL, 4X4 OR 2WD

PART # NP435 STYLE - 1974-91 A, D & W 100/350 TRUCK

MT-DG-NP435-# CORE - 30 DAYS
MT-DG-NP435-F 4 SPEED 2WD, IRON TAIL HOUSING
MT-DG-NP435-G 4 SPEED 4X4, ALUMINUM TAIL HOUSING
MT-DG-NP435-H 4 SPEED 4X4, W/ NP208 TRANSFER CASE
MT-DG-NP435-I 4 SPEED 4X4, W/ NP205 AND NP203 TRANSFER CASE
MT-DG-NP435-J 4 SPEED 4X4, W/ DIVORCED TRANSFER CASE
WHAT WE NEED TO KNOW: YEAR, MAKE, MODEL, 4X4 OR 2WD, ALL CASTING #'S & SPLINE COUNTS

PART # NP535 STYLE (NV2500) - 1987-92 DAKOTA, B150, B250, D100, D150

MT-DG-NP535-# CORE - 30 DAYS
MT-DG-NP535-A 5 SPEED 2WD, 1987-91, 23 SPLINE INPUT, DAKOTA
MT-DG-NP535-B 5 SPEED 4X4, 1987-91, 23 SPLINE INPUT, DAKOTA
MT-DG-NP535-C 5 SPEED 2WD, 1992-ON, 19 SPLINE INPUT, DAKOTA
MT-DG-NP535-D 5 SPEED 4X4, 1992-ON, 19 SPLINE INPUT, DAKOTA
MT-DG-NP535-E 5 SPEED 2WD, 1987-91, FULL SIZE TRUCK
WHAT WE NEED TO KNOW: YEAR, MAKE, MODEL, 4X4 OR 2WD, FULL SIZE OR DAKOTA, INPUT SPLINE COUNT (FOR DAKOTA - 19 OR 23)

PART # NV3500 STYLE - 1990-ON DAKOTA, FULL SIZE 1500 SERIES RAM

MT-DG-NV3500-# CORE - 30 DAYS
MT-DG-NV3500-A 5 SPEED 2WD, RAM (GET CASTING NUMBERS)
MT-DG-NV3500-B 5 SPEED 4X4, RAM (GET CASTING NUMBERS)
MT-DG-NV3500-C 5 SPEED 2WD, DAKOTA (GET CASTING NUMBERS)
MT-DG-NV3500-D 5 SPEED 4X4, DAKOTA (GET CASTING NUMBERS)
WHAT WE NEED TO KNOW: YEAR, MAKE, MODEL, 4X4 OR 2WD, FULL SIZE OR DAKOTA, CASTING NUMBERS FROM BOTH HALVES



DODGE® REBUILT TRANSMISSIONS (cont.)

UNIT

PAGE

PART# **G360 STYLE** - 1987-92 FULL SIZE 2500 SERIES DIESEL RAM

MT-DG-G360-# CORE - 30 DAYS
MT-DG-G360-A 5 SPEED 2WD, 1987-92, DODGE DIESEL, CAST IRON CASE, HAS "GETRAG" ON SIDE OF CASE
MT-DG-G360-B 5 SPEED 4X4, 1987-92, DODGE DIESEL, CAST IRON CASE, HAS "GETRAG" ON SIDE OF CASE
WHAT WE NEED TO KNOW: YEAR, MAKE, MODEL, 4X4 OR 2WD

PART # **NV4500 STYLE** - (MT8) - 1992-ON FULL SIZE 2500-3500 SERIES RAM

MT-DG-NV4500-# CORE - 30 DAYS
MT-DG-NV4500-A1 5 SPEED 4X4, 1992-93, HD (V10 OR DIESEL), ROUND TOP COVER (RARE)
MT-DG-NV4500-A2 5 SPEED 4X4, 1994-97, HD (V10 OR DIESEL), ROUND TOP COVER
MT-DG-NV4500-A3 5 SPEED 4X4, 1998-ON, HD (V10 OR DIESEL), SQUARE TOP COVER
MT-DG-NV4500-B1 5 SPEED 2WD, 1992-93, HD (V10 OR DIESEL), SPEEDO, ROUND TOP COVER (RARE)
MT-DG-NV4500-B2 5 SPEED 2WD, 1994-97, HD (V10 OR DIESEL), SPEEDO, ROUND TOP COVER
MT-DG-NV4500-B3 5 SPEED 2WD, 1998-ON, HD (V10 OR DIESEL), NO SPEEDO, SQUARE TOP COVER
MT-DG-NV4500-C1 5 SPEED 4X4, 1992-93, GAS, 19 SPLINE INPUT, ROUND TOP COVER (RARE)
MT-DG-NV4500-C2 5 SPEED 4X4, 1994-97, GAS, 10 SPLINE INPUT, ROUND TOP COVER
MT-DG-NV4500-C3 5 SPEED 4X4, 1998-ON, GAS, 10 SPLINE INPUT, SQUARE TOP COVER
MT-DG-NV4500-D1 5 SPEED 2WD, 1992-93, GAS, 19 SPLINE INPUT, SPEEDO, ROUND TOP COVER (RARE)
MT-DG-NV4500-D2 5 SPEED 2WD, 1994-97, GAS, 10 SPLINE INPUT, SPEEDO, ROUND TOP COVER
MT-DG-NV4500-D3 5 SPEED 2WD, 1998-ON, GAS, 10 SPLINE INPUT, NO SPEEDO, SQUARE TOP COVER
WHAT WE NEED TO KNOW: YEAR, MAKE, MODEL, 4X4 OR 2WD, GAS OR DIESEL, SPEEDO OR NO SPEEDO

PART # **NV5600 STYLE** - 1998-ON HEAVY DUTY TRUCKS

MT-DG-NV5600-# CORE - 30 DAYS
MT-DG-NV5600-A 6 SPEED 2WD, DIESEL
MT-DG-NV5600-B 6 SPEED 4X4, DIESEL
WHAT WE NEED TO KNOW: YEAR, MAKE, MODEL, 4X4 OR 2WD, DIAMETER OF INPUT AROUND THE SPLINES (EITHER 1-1/4" OR 1-3/8")

DODGE® REBUILT TRANSFER CASES

PART # **NP203 STYLE** - 1973-79 RAMCHARGER, 2100-300

TC-DG-NP203-# CORE - 30 DAYS
TC-DG-NP203-DA DODGE, NO PART TIME KIT
TC-DG-NP203-DB DODGE, W/ PART TIME KIT
WHAT WE NEED TO KNOW: YEAR, MAKE, MODEL, TAG #

PART # **NP205 STYLE** - 1982-93 W100-W350 RAM

TC-DG-NP205-# CORE - 30 DAYS
TC-DG-NP205-A DODGE, 1969-74, DIVORCED FROM TRANSMISSION
TC-DG-NP205-B DODGE, 1988-ON, 29 SPLINE INPUT, MARRIED TO TRANSMISSION DIESEL
TC-DG-NP205-C DODGE, 1988-ON, 23 SPLINE INPUT, MARRIED TO TRANSMISSION GAS
WHAT WE NEED TO KNOW: YEAR, MAKE, MODEL, SPLINE COUNT, MARRIED OR DIVORCED STYLE

PART # **NP207 STYLE** - 1987-ON DAKOTA, W150

TC-DG-NP207-# CORE - 30 DAYS
TC-DG-NP207-A DODGE, 1987-ON, 23 SPLINE INPUT
WHAT WE NEED TO KNOW: YEAR, MAKE, MODEL, TAG #

PART # **NP208 STYLE** - 1980-88 RAMCHARGER, PICKUPS

TC-DG-NP208-# CORE - 30 DAYS
TC-DG-NP208-DA DODGE, 23 SPLINE INPUT, BOLT ON REAR YOKE, MANUAL SHIFT
TC-DG-NP208-DB DODGE, 23 SPLINE INPUT, BOLT ON REAR YOKE, VACUUM SHIFT
WHAT WE NEED TO KNOW: YEAR, MAKE, MODEL, TAG #, MANUAL OR VACUUM SHIFT



DODGE® REBUILT TRANSFER CASES (cont.)

UNIT

PAGE

PART # NP231 STYLE - 1987-01 DAKOTA, W150 AND DURANGO

TC-DG-NP231-#	CORE - 30 DAYS 23 SPLINE INPUT, 26 SPLINE M/S, 1.75" SPEEDO HOLE, 1.55" EXPOSED INPUT SHAFT, SWITCH ON TAIL HOUSING.
TC-DG-NP231-DA	23 SPLINE INPUT, 27 SPLINE M/S, 1.75" SPEEDO HOLE, 1.55" EXPOSED INPUT SHAFT
TC-DG-NP231-DB	23 SPLINE INPUT, 27 SPLINE M/S, 1.75" SPEEDO HOLE, .84" EXPOSED INPUT SHAFT
TC-DG-NP231-DC	23 SPLINE INPUT, 26 SPLINE M/S, 1.75" SPEEDO HOLE, 1.55" EXPOSED INPUT SHAFT
TC-DG-NP231-DD	23 SPLINE INPUT, 32 SPLINE M/S, 1.75" SPEEDO HOLE, .84" EXPOSED INPUT SHAFT, FLAT CIRCULAR FRONT OUTPUT YOKE
TC-DG-NP231-DE	23 SPLINE INPUT, 32 SPLINE M/S, 1.75" SPEEDO HOLE, 1.55" EXPOSED INPUT SHAFT, FLAT CIRCULAR FRONT OUTPUT YOKE
TC-DG-NP231-DF	23 SPLINE INPUT, 26 SPLINE M/S, 1.75" SPEEDO HOLE, 1.55" EXPOSED NUT SHAFT
TC-DG-NP231-DG	23 SPLINE INPUT, 32 SPLINE M/S, NO SPEEDO, .840" EXPOSED INPUT SHAFT, 2-WIRE SWITCH **DHD**
TC-DG-NP231-DH	23 SPLINE INPUT, 27 SPLINE M/S, SPEEDO HOLE, .84" EXPOSED INPUT SHAFT
TC-DG-NP231-DI	23 SPLINE INPUT, 32 SPLINE M/S, NO SPEEDO, .84" EXPOSED INPUT SHAFT, FLAT CIRCULAR FRONT OUTPUT YOKE
TC-DG-NP231-DJ	23 SPLINE INPUT, 32 SPLINE M/S, NO SPEEDO, 1.55" EXPOSED INPUT SHAFT, FLAT CIRCULAR FRONT OUTPUT YOKE
TC-DG-NP231-DK	23 SPLINE INPUT, 27 SPLINE M/S, NO SPEEDO, .84" EXPOSED INPUT SHAFT
TC-DG-NP231-DL	23 SPLINE INPUT, 32 SPLINE M/S, NO SPEEDO, .84" EXPOSED INPUT SHAFT
TC-DG-NP231-DM	23 SPLINE INPUT, 32 SPLINE M/S, NO SPEEDO, .84" EXPOSED INPUT SHAFT

WHAT WE NEED TO KNOW: YEAR, MAKE, MODEL, TAG #

PART # NP233 STYLE - 2001-ON DURANGO, DAKOTA

TC-DG-NP233-#	CORE - 30 DAYS 23 SPLINE INPUT, 32 SPLINE RR. SLIP, NO SPEEDO HOLE, .840 EXPOSED INPUT, ELECTRIC SHIFT, CUP STYLE FRONT OUTPUT
TC-DG-NP233-A	

WHAT WE NEED TO KNOW: YEAR, MAKE, MODEL, TAG #

PART # NP241 STYLE - 1987-ON RAMCHARGER, W150-350 TRUCKS

TC-DG-NP241-#	CORE - 30 DAYS 23 SPLINE INPUT, 1.75" SPEEDO HOLE, 1.55" EXPOSED INPUT SHAFT, RT. HAND MOUNT, CIRCULAR FRONT OUTPUT YOKE
TC-DG-NP241-DA	23 SPLINE INPUT, 32 SPLINE M/S, SPEEDO, 1.55" EXPOSED INPUT SHAFT **DLD**
TC-DG-NP241-DB	23 SPLINE INPUT, 32 SPLINE M/S, 1.75" SPEEDO HOLE, 1.55" EXPOSED INPUT SHAFT W/ PTO, **DHD**
TC-DG-NP241-DC	23 SPLINE INPUT, 31 SPLINE M/S (1.61" DIA.), NO SPEEDO, 1.55" EXPOSED INPUT SHAFT, W/ PTO, **DHD**
TC-DG-NP241-DE	23 SPLINE INPUT, 32 SPLINE M/S, 1.75" SPEEDO HOLE, 1.55" EXPOSED INPUT SHAFT, **DLD**
TC-DG-NP241-DF	23 SPLINE INPUT, 32 SPLINE M/S, SPEEDO, .840" EXPOSED INPUT SHAFT, **DLD**
TC-DG-NP241-DG	23 SPLINE INPUT, 32 SPLINE M/S (1.375" DIA.), 1.75" SPEEDO HOLE, .840" EXPOSED INPUT SHAFT, W/ PTO, **DHD**
TC-DG-NP241-DH	23 SPLINE INPUT, 32 SPLINE M/S, NO SPEEDO, .840" EXPOSED INPUT SHAFT, **DLD**
TC-DG-NP241-DI	23 SPLINE INPUT, 31 SPLINE M/S (1.61" DIA.), NO SPEEDO, .840" EXPOSED INPUT SHAFT, W/ PTO, **DHD**
TC-DG-NP241-DJ	23 SPLINE INPUT, 32 SPLINE M/S, NO SPEEDO, 1.55" EXPOSED INPUT SHAFT **DLD**
TC-DG-NP241-DK	23 SPLINE INPUT, 31 SPLINE M/S (1.61" DIA.), SPEEDO, .840" EXPOSED INPUT SHAFT, W/ PTO, **DHD**
TC-DG-NP241-DL	29 SPLINE INPUT, 32 SPLINE M/S, 1.55" EXPOSED INPUT SHAFT, SPEEDO, **DLD**
TC-DG-NP241-DM	29 SPLINE INPUT, 32 SPLINE M/S, 1.55" EXPOSED INPUT SHAFT, NO SPEEDO, **DLD**
TC-DG-NP241-DN	29 SPLINE INPUT, 32 SPLINE M/S (1.375" DIA.), 1.75" SPEEDO HOLE, 1.55" EXPOSED INPUT SHAFT, W/ PTO, **DHD**
TC-DG-NP241-DO	29 SPLINE INPUT, 31 SPLINE M/S (1.61" DIA.), 1.55" EXPOSED INPUT SHAFT, SPEEDO, WITH PTO, **DHD**
TC-DG-NP241-DQ	29 SPLINE INPUT, 31 SPLINE M/S (1.61" DIA.), NO SPEEDO, 1.55" EXPOSED INPUT SHAFT, W/ PTO, **DHD**
TC-DG-NP241-DR	23 SPLINE INPUT, 32 RR. SLIP CIRCULAR OUTPUT YOKE, .84" EXPOSED INPUT SHAFT, W/ SPEEDO HOLE, **DLD**
TC-DG-NP241-DS	23 SPLINE INPUT, 2002-ON "NEW STYLE" 241-D, 6 BOLT 1 PC. TAIL HOUSING, EXPOSED SPL. FT OUTPUT SHAFT, 2 PRONG SWITCH ON FRONT CASE
TC-DG-NP241-DT	

WHAT WE NEED TO KNOW: YEAR, MAKE, MODEL, TAG #



DODGE® REBUILT TRANSFER CASES (cont.)

UNIT

PAGE

PART # NP242 STYLE - 1995-ON DAKOTA, DURANGO, HUMMER H1

TC-DG-NP242-# CORE - 30 DAYS
 TC-DG-NP242-A 23 SPLINE INPUT, 32 SPLINE SLIP RR., NO SPEEDO HOLE, 4-WIRE SHIFT INDICATOR
 23 SPLINE INPUT, 32 SPLINE SLIP RR., 2 PC. TAIL HOUSING, NO SPEEDO HOLE, 2-WIRE
 TC-DG-NP242-B SHIFT INDICATOR, .84" EXPOSED INPUT
 32 SPLINE INPUT, 32 SPLINE 44. SLIP OUTPUT, W/ OIL COOLER, ELECTRONIC SPEEDO
 TC-DG-NP242-C (1995-97 HUMMER H1)
 WHAT WE NEED TO KNOW: YEAR, MAKE, MODEL, TAG #

PART # NP243 STYLE

TC-GM-NP243-# CORE - 30 DAYS
 TC-GM-NP243-A CALL W/ TAG #
 WHAT WE NEED TO KNOW: YEAR, MAKE, MODEL, TAG #

PART # NP244 STYLE - 2001-ON DAKOTA

TC-GM-NP244-# CORE - 30 DAYS
 23 SPLINE INPUT, 32 SPLINE SLIP, RR. OUTPUT, CUP STYLE FRONT OUTPUT YOKE,
 TC-GM-NP244-A .84" EXPOSED INPUT SHAFT
 WHAT WE NEED TO KNOW: YEAR, MAKE, MODEL, TAG #

PART # NP271 STYLE - 2003-ON MECHANICAL SHIFT

TC-DG-NP271-# CORE - 30 DAYS
 23 SPLINE INPUT, RR. SLIP OUTPUT, MECHANICAL SHIFT, .84" EXPOSED INPUT,
 TC-DG-NP271-A 5 POSITION SWITCH
 29 SPLINE INPUT, RR. SLIP OUTPUT, MECHANICAL SHIFT, 1.55" EXPOSED INPUT,
 TC-DG-NP271-B 5 POSITION SWITCH
 23 SPLINE INPUT, RR. SLIP OUTPUT, MECHANICAL SHIFT, .84" EXPOSED INPUT,
 TC-DG-NP271-C 2-WIRE SHIFT INDICATOR, USED W/ AUTOMATIC
 29 SPLINE INPUT, RR. SLIP OUTPUT, MECHANICAL SHIFT, 1.55" EXPOSED INPUT,
 TC-DG-NP271-D 2-WIRE SHIFT INDICATOR, USED W/ MANUAL TRANSMISSION.
 WHAT WE NEED TO KNOW: YEAR, MAKE, MODEL, TAG #

PART # NP273 STYLE - 2003-ON ELECTRIC SHIFT

TC-DG-NP273-# CORE - 30 DAYS
 TC-DG-NP273-A 23 SPLINE INPUT, RR. SLIP OUTPUT, ELECTRIC SHIFT, .84" EXPOSED INPUT
 TC-DG-NP273-B 29 SPLINE INPUT, RR. SLIP OUTPUT, ELECTRIC SHIFT, 1.55" EXPOSED INPUT
 WHAT WE NEED TO KNOW: YEAR, MAKE, MODEL, TAG #

FORD® REBUILT TRANSMISSIONS

PART # RTS STYLE- 1983-ON F100/250

MT-FRD-RTS-# CORE - 30 DAYS
 MT-FRD-RTS-A 3 SPEED W/ O/D 2WD 1983-ON, ALUMINUM CASE AND TOP COVER
 MT-FRD-RTS-B 3 SPEED W/ O/D 4X4 1983-ON, ALUMINUM CASE AND TOP COVER
 WHAT WE NEED TO KNOW: YEAR, MAKE, MODEL

PART # RUG STYLE - 1977-1984 LIGHT DUTY TRUCKS AND VANS

MT-FRD-RUG-# CORE - 30 DAYS
 MT-FRD-RUG-A 3 SPEED O/D, ALL 2WD CARS 1978-81, IRON CASE, 10 BOLT TIN TOP COVER
 MT-FRD-RUG-B 3 SPEED O/D, 2 WD TRUCKS 1977-84 TRUCK, VAN, IRON CASE, 10 BOLT TOP COVER
 MT-FRD-RUG-C 3 SPEED O/D 4X4 TRUCKS 1977-84 TRUCK, VAN, IRON CASE, 10 BOLT TIN TOP COVER
 WHAT WE NEED TO KNOW: YEAR, MAKE, MODEL, 4X4 OR 2WD



FORD® REBUILT TRANSMISSIONS (cont.)

UNIT

PAGE

PART # SROD STYLE - 1981-1984 PASSENGER CAR, PICK-UP

MT-FRD-SROD-#	CORE - 30 DAYS 3 SPEED O/D, 1981-84, ALUMINUM CASE, 10 BOLT TIN TOP COVER, BRASS FORKS, CAR
MT-FRD-SROD-A	W/ 171 CU. INCH 3 SPEED O/D, 1981-84, ALUMINUM CASE, 10 BOLT TIN TOP COVER, BRASS FORKS, CAR
MT-FRD-SROD-B	W/ 250/302 CU. INCH 3 SPEED O/D, 1981-84, ALUMINUM CASE, 10 BOLT TIN TOP COVER, BRASS FORKS, CAR
MT-FRD-SROD-C	W/ 200 CU. INCH V8
MT-FRD-SROD-D	3 SPEED O/D, 81-84, ALUMINUM CASE, 10 BOLT TIN TOP COVER, BRASS FORKS, 2WD, TRUCK
MT-FRD-SROD-E	3 SPEED O/D, 81-84, ALUMINUM CASE, 10 BOLT TIN TOP COVER, BRASS FORKS, 4X4, TRUCK

WHAT WE NEED TO KNOW: YEAR, MAKE, MODEL, ENGINE SIZE

PART # T5 STYLE - 1982-98 MUSTANG, COUGAR, THUNDERBIRD, CAPRI

MT-FRD-T5-#	CORE - 30 DAYS
MT-FRD-T5-FA	5 SPEED 2WD, 1983-84, 4 CYL. AND V6, NON-WORLD CLASS
MT-FRD-T5-FB	5 SPEED 2WD, 1983-84, V8, NON-WORLD CLASS
MT-FRD-T5-FC	5 SPEED 2WD, 1985-93, 4 CYL. AND V6, WORLD CLASS
MT-FRD-T5-FD	5 SPEED 2WD, 1985-93, V8, WORLD CLASS
MT-FRD-T5-FE	5 SPEED 2WD, 1993, V8, WORLD CLASS "COBRA"
MT-FRD-T5-FF	5 SPEED 2WD, 1994-95, V8, WORLD CLASS "COBRA"
MT-FRD-T5-FG	5 SPEED 2WD, 1994-95, V6 AND V8
MT-FRD-T5-FH	5 SPEED 2WD, 1992-98, V6 ONLY
MT-FRD-T5-FI	5 SPEED 2WD, 1999-ON, V6 ELECTRONIC SPEEDO

WHAT WE NEED TO KNOW: YEAR, MAKE, MODEL, SPEEDO COLOR, SWITCH OR NO SWITCH ON TOP COVER, IS SWITCH ON DRIVER'S SIDE OR PASSENGER SIDE?

PART # T45 STYLE - 1996-01 V8, 4.6L

MT-FRD-T45-#	CORE - 30 DAYS
MT-FRD-T45-A	5 SPEED W/ CASTING NUMBER OF "1381" RWD

WHAT WE NEED TO KNOW: YEAR, MAKE, MODEL, ENGINE SIZE

PART # TK5 STYLE - 1983-87 BRONCO II, RANGER, AEROSTAR

MT-FRD-TK5-#	CORE - 30 DAYS
MT-FRD-TK5-A	5 SPEED 2WD, 4 CYL., BLACK SPEEDO, EXTERNAL SLAVE CYLINDER
MT-FRD-TK5-B	5 SPEED 2WD, V6, BLACK SPEEDO, EXTERNAL SLAVE CYLINDER
MT-FRD-TK5-C	5 SPEED 2WD, 4 CYL., BEIGE SPEEDO, EXTERNAL SLAVE CYLINDER
MT-FRD-TK5-D	5 SPEED 2WD, V6, BEIGE SPEEDO, EXTERNAL SLAVE CYLINDER
MT-FRD-TK5-E	5 SPEED 4X4, 4 CYL., EXTERNAL SLAVE CYLINDER
MT-FRD-TK5-F	5 SPEED 4X4, V6, EXTERNAL SLAVE CYLINDER
MT-FRD-TK5-G	5 SPEED 2WD, BLACK SPEEDO, INTERNAL SLAVE CYLINDER
MT-FRD-TK5-H	5 SPEED 2WD, BEIGE SPEEDO, INTERNAL SLAVE CYLINDER
MT-FRD-TK5-I	5 SPEED 4X4, INTERNAL SLAVE CYLINDER

WHAT WE NEED TO KNOW: YEAR, MAKE, MODEL, 4X4 OR 2WD, ENGINE SIZE, TUBE OR NO TUBE ON FRONT BEARING RET.

PART # NP435 STYLE - 1963-85 BRONCO, F100, F350, E350

MT-FRD-NP435-#	CORE - 30 DAYS
MT-FRD-NP435-A	4 SPEED 2WD, 1964-ON, IRON CASE, 28 SPLINE MAINSHAFT, BOLT YOKE STYLE
MT-FRD-NP435-B	4 SPEED 2WD, 1965-ON, IRON CASE, 32 SPLINE MAINSHAFT, BOLT YOKE STYLE
MT-FRD-NP435-C	4 SPEED 2WD, 1983-86, IRON CASE, 31 SPLINE MAINSHAFT, SLIP YOKE
MT-FRD-NP435-D	4 SPEED 4X4, 1964-77, IRON CASE, DIVORCED TRANSFER CASE
MT-FRD-NP435-E	4 SPEED 4X4, 1977-ON, IRON CASE, MARRIED TRANSFER CASE

WHAT WE NEED TO KNOW: YEAR, MAKE, MODEL, 4X4 OR 2WD, ALL CASTING #'S & SPLINE COUNTS

PART # T18 STYLE - 1966-73 HEAVY DUTY TRUCKS

MT-FRD-T18-#	CORE - 30 DAYS
MT-FRD-T18-A	4 SPEED 2WD, BOLT ON YOKE, "1301" CASTING ON CASE
MT-FRD-T18-B	4 SPEED 2WD, SLIP YOKE, "1301" CASTING ON CASE
MT-FRD-T18-C	4 SPEED 4X4, MARRIED TO TRANSFER CASE

WHAT WE NEED TO KNOW: YEAR, MAKE, MODEL, 4X4 OR 2WD, ALL CASTING #'S & SPLINE COUNTS



FORD® REBUILT TRANSMISSIONS (cont.)

UNIT _____ PAGE _____

PART # T19 STYLE - 1974-86 F100/250

MT-FRD-T19-# CORE - 30 DAYS
 MT-FRD-T19-A 4 SPEED 2WD, GAS, "1309" CASTING ON CASE
 MT-FRD-T19-B 4 SPEED 2WD, DIESEL, "1309" CASTING ON CASE
 MT-FRD-T19-C 4 SPEED 2WD, GAS, "1309" CASTING ON CASE
 MT-FRD-T19-D 4 SPEED 4X4, DIESEL, "1309" CASTING ON CASE
WHAT WE NEED TO KNOW: YEAR, MAKE, MODEL, 4X4 OR 2WD, GAS OR DIESEL, CAST # FROM TAIL HOUSING

PART # FM132 STYLE - 1985-ON BRONCO II, RANGER

MT-FRD-FM132-# CORE - 30 DAYS
 MT-FRD-FM132 5 SPEED 2WD, MITSUBISHI* STYLE W/ STEEL BOTTOM PAN
WHAT WE NEED TO KNOW: YEAR, MAKE, MODEL

PART # FM145 STYLE - 1985-87 BRONCO II, RANGER, EXPLORER

MT-FRD-FM145-# CORE - 30 DAYS
 MT-FRD-FM145 5 SPEED 4X4, MITSUBISHI STYLE W/ STEEL BOTTOM PAN, 10.5" EXT. HOUSING
WHAT WE NEED TO KNOW: YEAR, MAKE, MODEL

PART # FM-146 STYLE - 1988-92 BRONCO II, RANGER, EXPLORER

MT-FRD-FM146-# CORE - 30 DAYS
 MT-FRD-FM146 5 SPEED 4X4, MITSUBISHI STYLE W/ STEEL BOTTOM PAN, 13" EXT. HOUSING
WHAT WE NEED TO KNOW: YEAR, MAKE, MODEL

PART # M5R1 STYLE - 1988-98 AEROSTAR, BRONCO II, RANGER, EXPLORER

MT-FRD-M5R1-# CORE - 30 DAYS
 MT-FRD-M5R1-A1 5 SPEED 4X4, 1988-94, 4.0/2.9L
 MT-FRD-M5R1-A2 5 SPEED 4X4, 1995-ON, 4.0/2.9L
 MT-FRD-M5R1-B1 5 SPEED 2WD, 1988-94, 4.0/2.9L, PURPLE 6T SPEEDO
 MT-FRD-M5R1-B2 5 SPEED 2WD, 1995-ON, 4.0/2.9L, PURPLE 6T SPEEDO
 MT-FRD-M5R1-C1 5 SPEED 2WD, 1988-94, 4.0/2.9L, NO SPEEDO
 MT-FRD-M5R1-C2 5 SPEED 2WD, 1995-ON, 4.0/2.9L, NO SPEEDO
 MT-FRD-M5R1-D1 5 SPEED 2WD, 1988-94, 4.0/2.9L, WHITE 7 TOOTH SPEEDO
 MT-FRD-M5R1-D2 5 SPEED 2WD, 1995-ON, 4.0/2.9L, WHITE 7 TOOTH SPEEDO
 MT-FRD-M5R1-E 5 SPEED 2WD, 3.0L, W/ SPEEDO, AEROSTAR ONLY
 MT-FRD-M5R1-F 5 SPEED 2WD, 3.0L, NO SPEEDO, AEROSTAR ONLY
 MT-FRD-M5R1-G1 5 SPEED 4X4, 1988-94, 3.0L
 MT-FRD-M5R1-G2 5 SPEED 4X4, 1995ON, 3.0L
 MT-FRD-M5R1-H1 5 SPEED 2WD, 1988-94, 3.0L, PURPLE 6T SPEEDO
 MT-FRD-M5R1-H2 5 SPEED 2WD, 1995-ON, 3.0L, PURPLE 6T SPEEDO
 MT-FRD-M5R1-I1 5 SPEED 2WD, 1988-94, 3.0L, NO SPEEDO
 MT-FRD-M5R1-I2 5 SPEED 2WD, 1995-ON, 3.0L, NO SPEEDO
 MT-FRD-M5R1-J1 5 SPEED 2WD, 1988-94, 3.0L, WHITE 7T SPEEDO
 MT-FRD-M5R1-J2 5 SPEED 2WD, 1995-ON, 3.0L, WHITE 7T SPEEDO
 MT-FRD-M5R1-K1 5 SPEED 4X4, 1988-94, 2.3L, 1 OR 2 SWITCH
 MT-FRD-M5R1-K2 5 SPEED 4X4, 1995-ON, 2.3L, 1 OR 2 SWITCH
 MT-FRD-M5R1-M 5 SPEED 2WD, 1988-94, 2.3L, 1 OR 2 SWITCH, PURPLE 6T SPEEDO
 MT-FRD-M5R1-N 5 SPEED 2WD, 1995-ON, 2.3L, 1 OR 2 SWITCH, PURPLE 6T SPEEDO
 MT-FRD-M5R1-O1 5 SPEED 2WD, 1988-94, 2.3L, 1 OR 2 SWITCH, NO SPEEDO
 MT-FRD-M5R1-O2 5 SPEED 2WD, 1995-ON, 2.3L, 1 OR 2 SWITCH, NO SPEEDO
 MT-FRD-M5R1-P 5 SPEED 2WD, 1988-94, 2.3L, 1 OR 2 SWITCH, WHITE 7T SPEEDO
 MT-FRD-M5R1-Q 5 SPEED 2WD, 1995-ON, 2.3L, 1 OR 2 SWITCH, WHITE 7T SPEEDO
 MT-FRD-M5R1-R 5 SPEED 2SD, 1998-ON, 3.0L, 1 SWITCH, TRIGGER WHEEL SPEEDO
WHAT WE NEED TO KNOW: YEAR, MAKE, MODEL, ENGINE SIZE, 4X4 OR 2WD, SPEEDO COLOR, # OF SWITCHES ON TOP COVER



FORD® REBUILT TRANSMISSIONS (cont.)

UNIT

PAGE

PART # M5R2 STYLE - 1988-98 BRONCO, F150, E150, F250, E350

MT-FRD-M5R2-#	CORE - 30 DAYS
MT-FRD-M5R2-A	5 SPEED 4X4, 1988-96
MT-FRD-M5R2-B	5 SPEED 2WD, 1988-96, GREEN 8T SPEEDO
MT-FRD-M5R2-C	5 SPEED 2WD, 1988-96, NO SPEEDO
MT-FRD-M5R2-D	5 SPEED 2WD, 1988-96, WHITE 7T SPEEDO
MT-FRD-M5R2-E	5 SPEED 4X4, V6, 1997-ON
MT-FRD-M5R2-F	5 SPEED 4X4, V8, 1997-ON
MT-FRD-M5R2-G	5 SPEED 2WD, V6, 1997-98 GREEN 8T SPEEDO
MT-FRD-M5R2-H	5 SPEED 2WD, V8, 1997-98 GREEN 8T SPEEDO
MT-FRD-M5R2-I	5 SPEED 2WD, V6, 1997-98 WHITE 7T SPEEDO
MT-FRD-M5R2-J	5 SPEED 2WD, V8, 1997-98 WHITE 7T SPEEDO
MT-FRD-M5R2-K	5 SPEED 2WD, V6, 1999-ON, HAS TONE WHEEL INSTEAD OF SPEEDO
MT-FRD-M5R2-L	5 SPEED 2WD, V8, 1999-ON, HAS TONE WHEEL INSTEAD OF SPEEDO

WHAT WE NEED TO KNOW: YEAR, MAKE, MODEL, ENGINE SIZE, 4X4 OR 2WD, SPEEDO COLOR

PART # ZF STYLE - 1987-ON F250, F350, SUPERDUTY

MT-FRD-ZF-#	5 SPEED CORE - 30 DAYS
MT-FRD-ZF-6#	6 SPEED CORE- 30 DAYS
MT-FRD-ZF-100	5 SPEED 1987-95, 4X4, ZF TAG NUMBER: 1307050005, 031, 043, 058, 081, 100, 109
MT-FRD-ZF-102	5 SPEED 1987-95, 4X4, ZF TAG NUMBER: 1307050021, 032, 060, 082, 102
MT-FRD-ZF-103	5 SPEED 1987-95, 4X4, ZF TAG NUMBER: 1307050036, 044, 065, 086, 103
MT-FRD-ZF-118	5 SPEED 1987-95, 4X4, ZF TAG NUMBER: 1307050011, 052, 079, 096, 118
MT-FRD-ZF-120	5 SPEED 1987-95, 4X4, ZF TAG NUMBER: 1307050003, 030, 042, 055, 080, 098, 120
MT-FRD-ZF-111	5 SPEED 1994.5-95, 4X4, ZF 7.3 TD, ZF TAG NUMBER: 1307050111 (RATIO: 5.72-0.76)
MT-FRD-ZF-109	5 SPEED 1994.5-95, 4X4, ZF 7.3 TD, ZF TAG NUMBER: 1307050109 (RATIO: 4.14-0.77)
MT-FRD-ZF-050	5 SPEED 1987-95, 2WD, ZF TAG NUMBER: 1307050050, 012, 068, 096, 117
MT-FRD-ZF-051	5 SPEED 1987-95, 2WD, ZF TAG NUMBER: 1307050051, 039
MT-FRD-ZF-053	5 SPEED 1987-95, 2WD, ZF TAG NUMBER: 1307050053, 014, 069, 097, 119
MT-FRD-ZF-054	5 SPEED 1987-95, 2WD, ZF TAG NUMBER: 1307050054
MT-FRD-ZF-056	5 SPEED 1987-95, 2WD, ZF TAG NUMBER: 1307050056, 004, 070, 099
MT-FRD-ZF-057	5 SPEED 1987-95, 2WD, ZF TAG NUMBER: 1307050057
MT-FRD-ZF-059	5 SPEED 1987-95, 2WD, ZF TAG NUMBER: 1307050022, 059, 071, 101
MT-FRD-ZF-064	5 SPEED 1987-95, 2WD, ZF TAG NUMBER: 1307050064, 034, 061
MT-FRD-ZF-108	5 SPEED 1994.5-95, 2WD, ZF 7.3 TD, ZF TAG NUMBER: 1307050108 (RATIO: 4.14-0.77)
MT-FRD-ZF-110	5 SPEED 1994.5-95, 2WD, ZF 7.3 TD, ZF TAG NUMBER: 1307050110 (RATIO: 5.72-0.76)
MT-FRD-ZF-002	5 SPEED 1996-ON, 4X4, ZF TAG NUMBER: 1317050002
MT-FRD-ZF-004	5 SPEED 1996-ON, 4X4, ZF TAG NUMBER: 1317050004, 012
MT-FRD-ZF-007	5 SPEED 1996-ON, 4X4, ZF TAG NUMBER: 1317050007, 013
MT-FRD-ZF-012	5 SPEED 1996-ON, 4X4, ZF TAG NUMBER: 1317050012, 004
MT-FRD-ZF-013	5 SPEED 1996-ON, 4X4, ZF TAG NUMBER: 1317050013, 007
MT-FRD-ZF-015	5 SPEED 1996-ON, 4X4, ZF TAG NUMBER: 1317050015, 008
MT-FRD-ZF-001	5 SPEED 1996-ON, 2WD, ZF TAG NUMBER: 1317050001
MT-FRD-ZF-003	5 SPEED 1996-ON, 2WD, ZF TAG NUMBER: 1317050003
MT-FRD-ZF-006	5 SPEED 1996-ON, 2WD, ZF TAG NUMBER: 1317050006
MT-FRD-ZF-016	5 SPEED 1996-ON, 2WD, ZF TAG NUMBER: 1317050016, 014
MT-FRD-ZF-602	6 SPEED 1999-00, 4X4, ZF TAG NUMBER: 1319050002, 006, 023 DIESEL
	6 SPEED 2001-ON, 4X4, ZF TAG NUMBER: 1319050025, 036, 046 (HIGH TORQUE) DIESEL
MT-FRD-ZF-625	6 SPEED 1999-00, 2WD, ZF TAG NUMBER: 1319050004, 005, 022 DIESEL
MT-FRD-ZF-604	6 SPEED 2001-ON, 2WD, ZF TAG NUMBER: 1319050024, 037, 045 (HIGH TORQUE) DIESEL,

MT-FRD-ZF-624

WHAT WE NEED TO KNOW: YEAR, MAKE, MODEL, TAG #



FORD® REBUILT TRANSFER CASES

UNIT

PAGE

PART # **BW1345 STYLE - 1980-92 F250**

TC-FRD-BW1345-# **CORE - 30 DAYS**
 TC-FRD-BW1345-A 1980-82, 32 SPLINE INPUT, 2" SPEEDO HOLE, 6, 7, OR 8 T SPEEDO
 TC-FRD-BW1345-B 1982-87, 32 SPLINE INPUT, .875" SPEEDO HOLE, 6, 7, OR 8 T SPEEDO
 TC-FRD-BW1345-C 1988-91, 31 SPLINE INPUT, .875" SPEEDO HOLE, 6, 7, OR 8 T SPEEDO
WHAT WE NEED TO KNOW: YEAR, MAKE, MODEL, TAG #

PART # **BW1350 STYLE - 1983-89 BRONCO II, RANGER, EXPLORER**

TC-FRD-BW1350-# **CORE - 30 DAYS**
 TC-FRD-BW1350-A MANUAL SHIFT, BOLT ON SHIFT LINKAGE, NO EXTERNAL FRONT YOKE
 TC-FRD-BW1350-B MANUAL SHIFT, 1 PC. SHIFT LINKAGE, NO EXTERNAL FRONT YOKE
 TC-FRD-BW1350-C MANUAL SHIFT, W/ EXTERNAL FRONT YOKE
 TC-FRD-BW1350-D ELECTRIC SHIFT, W/ EXTERNAL FRONT YOKE
 TC-FRD-BW1350-G ELECTRIC SHIFT, NO EXTERNAL FRONT YOKE
WHAT WE NEED TO KNOW: YEAR, MAKE, MODEL, TAG #

PART # **BW1354 STYLE- 1988-ON F150, BRONCO**

TC-FRD-BW1354-# **CORE - 30 DAYS**
 TC-FRD-BW1354-A ALL MANUAL SHIFT
 TC-FRD-BW1354-B 1990-95, ELECTRIC SHIFT W/ SPEEDO HOLE & SENSOR HOLE, FIXED FRONT OUTPUT YOKE
 TC-FRD-BW1354-C 1995-98, ELECTRIC SHIFT W/ SPEEDO HOLE, NO SENSOR HOLE, FIXED FRONT OUTPUT YOKE, RR. CIRCULAR FLANGE
 TC-FRD-BW1354-D 1998-00, ELECTRIC SHIFT, NO SPEEDO HOLE, NO SENSOR HOLE, FIXED FRONT OUTPUT CUP STYLE YOKE, RR. CIRCULAR FLANGE
 TC-FRD-BW1354-E 2000-ON, ELECTRIC SHIFT, NO SPEEDO HOLE, NO SENSOR HOLE, FIXED FRONT OUTPUT CUP STYLE YOKE, RR. CIRCULAR FLANGE
WHAT WE NEED TO KNOW: YEAR, MAKE, MODEL, TAG #

PART # **BW1356 STYLE - 1987-96 BRONCO, F150, F250**

TC-FRD-BW1356-# **CORE - 30 DAYS**
 TC-FRD-BW1356-A BOLT LINKAGE, SLIP YOKE
 TC-FRD-BW1356-B BOLT LINKAGE, SLIP YOKE, W/ PTO
 TC-FRD-BW1356-C WELDED LINKAGE, SLIP YOKE
 TC-FRD-BW1356-D WELDED LINKAGE, SLIP YOKE, W/ PTO
 TC-FRD-BW1356-E BOLT LINKAGE, BOLT ON U-JOINT
 TC-FRD-BW1356-F BOLT LINKAGE BOLT ON -JOINT W/ PTO
 TC-FRD-BW1356-G BOLT LINKAGE, ROUND FLANGE YOKE
 TC-FRD-BW1356-H BOLT LINKAGE, ROUND FLANGE YOKE, W/ PTO
 TC-FRD-BW1356-I WELDED LINKAGE, BOLT ON U-JOINT
 TC-FRD-BW1356-J WELDED LINKAGE, BOLT ON U-JOINT, W/ PTO
 TC-FRD-BW1356-K WELDED LINKAGE, ROUND FLANGE YOKE
 TC-FRD-BW1356-L WELDED LINKAGE, ROUND FLANGE YOKE, W/ PTO
 TC-FRD-BW1356-M ELECTRIC SHIFT, SLIP YOKE
 TC-FRD-BW1356-N ELECTRIC SHIFT, SLIP YOKE, W/ PTO
 TC-FRD-BW1356-O ELECTRIC SHIFT, BOLT ON U-JOINT
 TC-FRD-BW1356-P ELECTRIC SHIFT, BOLT ON U-JOINT, W/ PTO
 TC-FRD-BW1356-Q ELECTRIC SHIFT, ROUND FLANGE
 TC-FRD-BW1356-R ELECTRIC SHIFT, ROUND FLANGE, W/ PTO
WHAT WE NEED TO KNOW: YEAR, MAKE, MODEL, TAG #, SPEEDO COLOR, PLUS ALL DESCRIPTION INFORMATION ABOVE

PART # **BW4404 STYLE - 1996-ON EXPLORER, MOUNTAINEER**

TC-FRD-BW4404-# **CORE - 30 DAYS**
 TC-FRD-BW4404-A FORD, 4X4, FIXED FLAT FLANGE FRONT OUTPUT, 7T SPEEDO
 TC-FRD-BW4404-B FORD, 4X4, FIXED CUPPED FLANGE FRONT OUTPUT, 7T SPEEDO
 TC-FRD-BW4404-C FORD, 4X4, FIXED CUPPED FLANGE FRONT OUTPUT, NO SPEEDO
WHAT WE NEED TO KNOW: YEAR, MAKE, MODEL, TAG #



FORD® REBUILT TRANSFER CASES (cont.)

UNIT

PAGE

PART # **BW4405 STYLE** - 1995-99 EXPLORER, MOUNTAINEER

TC-FRD-BW4405-# CORE - 30 DAYS
TC-FRD-BW4405-A DBL. CARDAN FRONT OUTPUT, CIRCULAR RR. ROUND FLANGE OUTPUT
TC-FRD-BW4405-B FIXED CUPPED FLANGE FRONT & RR. OUTPUT, 7T SPEEDO
TC-FRD-BW4406-C FIXED CUPPED FLANGE FRONT & RR. OUTPUT, NO SPEEDO

WHAT WE NEED TO KNOW: YEAR, MAKE, MODEL, TAG #

PART # **BW4406 STYLE**- 1997-ON F150, F250, EXPEDITION, NAVIGATOR

TC-FRD-BW4406-# CORE - 30 DAYS
TC-FRD-BW4406-A MANUAL SHIFT, W/ SPEEDO HOLE, 8T BROWN SPEEDO, SHIFT ON FLY (NO T.O.D.)
TC-FRD-BW4406-B MANUAL SHIFT, W/O SPEEDO HOLE, SHIFT ON FLY (NO T.O.D.)
TC-FRD-BW4406-C ELECTRIC SHIFT, W/ SPEEDO HOLE, 8T BROWN SPEEDO, SHIFT ON FLY (NO T.O.D.)
TC-FRD-BW4406-D ELECTRIC SHIFT, W/O SPEEDO HOLE, SHIFT ON FLY (NO T.O.D.)
TC-FRD-BW4406-E ELECTRIC SHIFT, T.O.D., W/ SPEEDO HOLE, FRONT & RR. SENSOR HOLES
TC-FRD-BW4406-F ELECTRIC SHIFT, T.O.D., W/O SPEEDO HOLE, FRONT & RR. SENSOR HOLES

WHAT WE NEED TO KNOW: YEAR, MAKE, MODEL, TAG #

PART # **BW4407 STYLE** - 1996-98 FW250, F350

TC-FRD-BW4407-# CORE - 30 DAYS
TC-FRD-BW4407-A MECHANICAL SHIFT, W/ PTO
TC-FRD-BW4407-B MECHANICAL SHIFT, W/O PTO

WHAT WE NEED TO KNOW: YEAR, MAKE, MODEL, TAG #

PART # **BW4410 STYLE** - 2002-ON EXPLORER, MOUNTAINEER (ELECTRIC SHIFT)

TC-FRD-BW4410-# CORE - 30 DAYS
FRONT CUP STYLE YOKE, RR. CIRCULAR FLANGE, NO SPEEDO HOLE, VISCOUS
TC-FRD-BW4410-A DRIVE, AWD

WHAT WE NEED TO KNOW: YEAR, MAKE, MODEL, TAG #

PART # **BW4411 STYLE** - 2002-ON EXPLORER, MOUNTAINEER (ELECTRIC SHIFT)

TC-FRD-BW4411-# CORE - 30 DAYS
TC-FRD-BW4411-A FRONT CUP STYLE YOKE, RR. CIRCULAR FLANGE, NO SPEEDO HOLE

WHAT WE NEED TO KNOW: YEAR, MAKE, MODEL, TAG #

PART # **BW4416 STYLE** - 2003-ON F150 (ELECTRIC SHIFT)

TC-FRD-BW4416-# CORE - 30 DAYS
TC-FRD-BW4416-A 32 SPLINE INPUT, RR. SLIP, W/O T.O.D., NO SPEEDO HOLE

WHAT WE NEED TO KNOW: YEAR, MAKE, MODEL, TAG #

PART # **DANA 28 STYLE** - 1990-96 AEROSTAR AWD MODELS

TC-FRD-DANA28-# CORE - 30 DAYS
TC-FRD-DANA28-A FORD, 4X4, MECHANICAL SPEEDO
TC-FRD-DANA28-B FORD, 4X4, ELECTRONIC SPEEDO

WHAT WE NEED TO KNOW: YEAR, MAKE, MODEL, TAG #

PART # **NP203 STYLE** - 1973-79 F150, F250, BRONCO

TC-FRD-NP203-# CORE - 30 DAYS
TC-FRD-NP203-FA FORD, 4X4, MARRIED W/O PART TIME KIT
TC-FRD-NP203-FB FORD, 4X4, MARRIED W/ PART TIME KIT
TC-FRD-NP203-FC FORD, 4X4, DIVORCED W/O PART TIME KIT
TC-FRD-NP203-FD FORD, 4X4, DIVORCED W/ PART TIME KIT

WHAT WE NEED TO KNOW: YEAR, MAKE, MODEL, TAG #



FORD® REBUILT TRANSFER CASES (cont.)

UNIT

PAGE

PART # NP205 STYLE - 1973-79 F150, F250, BRONCO

TC-FRD-NP205-# CORE - 30 DAYS
 TC-FRD-NP205-FA FORD, 4X4, MARRIED MOUNT, USED W/ C6 AUTOMATIC
 TC-FRD-NP205-FB FORD, 4X4, REMOTE MOUNT
 WHAT WE NEED TO KNOW: YEAR, MAKE, MODEL, TAG #

PART # NP208 STYLE - 1980-86 F150, F250, BRONCO

TC-FRD-NP208-# CORE - 30 DAYS
 TC-FRD-NP208-FA 31 SPLINE INPUT, BOLT REAR YOKE, BLUE SPEEDO
 TC-FRD-NP208-FB 31 SPLINE INPUT, BOLT REAR YOKE, WHITE SPEEDO
 TC-FRD-NP208-FC 31 SPLINE INPUT, SLIP REAR YOKE, BLUE SPEEDO
 TC-FRD-NP208-FD 31 SPLINE INPUT, SLIP REAR YOKE, WHITE SPEEDO
 WHAT WE NEED TO KNOW: YEAR, MAKE, MODEL, TAG #

PART # NV271 STYLE - 1998-ON F250-550 SUPERDUTY

TC-FRD-NV271-# CORE - 30 DAYS
 TC-FRD-NV271-A 31 SPLINE INPUT, MECHANICAL SHIFT, USED W/ AUTOMATIC OR 5 SPEED MANUAL
 TC-FRD-NV271-B 24 SPLINE INPUT, MECHANICAL SHIFT, USED W/ 6 SPEED
 TC-FRD-NV271-C 34 SPLINE INPUT, MECHANICAL SHIFT, USED W/ 5 SPEED AUTOMATIC
 WHAT WE NEED TO KNOW: YEAR, MAKE, MODEL, TAG #

PART # NV273 STYLE - 1999-ON F250-550 SUPERDUTY

TC-FRD-NV273-# CORE - 30 DAYS
 TC-FRD-NV273-A 31 SPLINE INPUT, ELECTRIC SHIFT, USED W/ AUTOMATIC OR 5 SPEED MANUAL
 TC-FRD-NV273-B 24 SPLINE INPUT, ELECTRIC SHIFT, USED W/ 6 SPEED
 TC-FRD-NV273-C 34 SPLINE INPUT, ELECTRIC SHIFT, NO SPEEDO, USED W/ 5 SPEED AUTOMATIC
 WHAT WE NEED TO KNOW: YEAR, MAKE, MODEL, TAG #

GMC® REBUILT TRANSMISSIONS

PART # T4 STYLE - 1982-88 S10

MT-GM-T4-# CORE - 30 DAYS
 MT-GM-T4-A 4 SPEED, 2WD, 1982-87, S10
 MT-GM-T4-B 4 SPEED, 4X4, 1982-87, S10
 WHAT WE NEED TO KNOW: YEAR, MAKE, MODEL

PART # T5 STYLE - 1982-98 CAMARO, FIREBIRD, S10/15, ASTRO SAFARI VAN, CHEVETTE

MT-GM-T5-# CORE - 30 DAYS
 MT-GM-T5-CA 5 SPEED 1985-89, ASTROVAN
 MT-GM-T5-CB 5 SPEED 1982-87, 4 CYL. AND V6, NON-WORLD CLASS, CAMARO
 MT-GM-T5-CC 5 SPEED 1982-97, V8, CAMARO NON-WORLD CLASS
 MT-GM-T5-CD 5 SPEED 1982-92, 4 CYL. AND V6, CAMARO, WORLD CLASS
 MT-GM-T5-CE 5 SPEED 1988-ON, V8, CAMARO, WORLD CLASS
 MT-GM-T5-CF 5 SPEED 1983-ON, S10 AND S15
 MT-GM-T5-CG 5 SPEED 1982-ON, S10, PLASTIC MECHANICAL SPEEDO, NON-WORLD CLASS
 MT-GM-T5-CH 5 SPEED 1982-ON, S10, ELECTRONIC SPEEDO, NON-WORLD CLASS
 MT-GM-T5-CI 5 SPEED 1989-ON, S10, 14 SPLINE, WORLD CLASS
 MT-GM-T5-CJ 5 SPEED 1994-ON, S10, 26 SPLINE, WORLD CLASS
 MT-GM-T5-CK 5 SPEED 1982-ON, CHEVETTE
 MG-GM-T5-CL 5 SPEED 1993-95, V6 CAMARO, WORLD CLASS
 MG-GM-T5-CM 5 SPEED 1996-ON, V6 CAMARO, WORLD CLASS
 WHAT WE NEED TO KNOW: YEAR, MAKE, MODEL, TAG # (IF POSSIBLE), SPEEDO COLOR



GMC® REBUILT TRANSMISSIONS (cont.)

UNIT

PAGE

PART # T56 STYLE - 1993-ON CAMARO, FIREBIRD, CORVETTE

MT-GM-T56-# **CORE - 30 DAYS**
 MT-GM-T56-A 6 SPEED V8, 1993-97, CAMARO AND FIREBIRD GET CAST NUMBER OFF CASE
 MT-GM-T56-B 6 SPEED V8, 1997-ON, CAMARO AND FIREBIRD GET CAST NUMBER OFF CASE
 MT-GM-T56-C 6 SPEED 1997-ON CORVETTE

WHAT WE NEED TO KNOW: YEAR, MAKE, MODEL, TAG #

PART # SM465 STYLE - 1968-91 PICK-UP, VANS AND TRUCKS

MT-GM-SM465-# **CORE - 30 DAYS**
 MT-GM-SM465-A 4 SPEED 1968-72, NO TAIL HOUSING MOUNT
 MT-GM-SM465-B 4 SPEED 1973-ON, W/ TAIL HOUSING MOUNT
 MT-GM-SM465-C 4 SPEED 1968-ON, 1-1/2" SPLINE INPUT, NO TAIL HOUSING MOUNT
 MT-GM-SM465-D 4 SPEED 1968-72, 10 SPLINE OUTPUT, THREADED HOLES IN CASE
 MT-GM-SM465-E 4 SPEED 1973-87, 10 SPLINE OUTPUT, NO THREADED HOLES IN CASE
 MT-GM-SM465-F 4 SPEED 1981-91, 32 SPLINE OUTPUT
 MT-GM-SM465-G 4 SPEED 1988-ON, 2WD, W/ ALUMINUM TOP COVER, MECHANICAL SPEEDO
 MT-GM-SM465-H 4 SPEED 1988-ON, 2WD, W/ ALUMINUM TOP COVER, ELECTRONIC SPEEDO
 M-GM-SM465-I 4 SPEED 1988-ON, 4X4, W/ ALUMINUM TOP COVER

WHAT WE NEED TO KNOW: YEAR, MAKE, MODEL, 4X4 OR 2WD, ALL CASTING #'S & SPLINE COUNTS

PART # NV1500 STYLE - 1996-ON S10

MT-GM-NV1500-# **CORE - 30 DAYS**
 MT-GM-NV1500 5 SPEED 2WD, 4 CYL. 17.5" TAIL, S10

WHAT WE NEED TO KNOW: YEAR, MAKE, MODEL

PART # GETRAG 290 STYLE (NV3500) - 1988-ON S10 AND FULL SIZE TRUCKS

MT-GM-290-# **CORE - 30 DAYS**
 MT-GM-NV3500-# **CORE - 30 DAYS**
 MT-GM-290-A1 5 SPEED 4X4, 1988-95, S10, TUBE STYLE FRONT RETAINER
 MT-GM-290-A2 5 SPEED 4X4, 1988-95, FULL SIZE, TUBE STYLE FRONT RETAINER
 MT-GM-290-B1 5 SPEED 2WD, 1988-95, S10, TUBE STYLE FRONT RETAINER
 MT-GM-290-B2 5 SPEED 2WD, 1988-95, FULL SIZE, TUBE STYLE FRONT RETAINER
 MT-GM-NV3500-A1 5 SPEED 4X4, 1995-99, S10, FLAT ALUMINUM, FRONT RETAINER (NO TUBE)
 MT-GM-NV3500-A2 5 SPEED 4X4, 1995-99, FULL SIZE, FLAT ALUMINUM, FRONT RETAINER (NO TUBE)
 MT-GM-NV3500-A3 5 SPEED 4X4, 1999-ON, S10, FLAT ALUMINUM, FRONT RETAINER (NO TUBE)
 MT-GM-NV3500-A4 5 SPEED 4X4, 1999-ON, FULL SIZE, FLAT ALUMINUM, FRONT RETAINER (NO TUBE)
 MT-GM-NV3500-B1 5 SPEED 2WD, 1995-99, S10, FLAT ALUMINUM, FRONT RETAINER (NO TUBE)
 MT-GM-NV3500-B2 5 SPEED 2WD, 1995-99, FULL SIZE, FLAT ALUMINUM, FRONT RETAINER (NO TUBE)
 MT-GM-NV3500-B3 5 SPEED 2WD, 1999-ON, S10, FLAT ALUMINUM, FRONT RETAINER (NO TUBE)
 MT-GM-NV3500-B4 5 SPEED 2WD, 1999-ON, FULL SIZE, FLAT ALUMINUM, FRONT RETAINER (NO TUBE)

WHAT WE NEED TO KNOW: YEAR, MAKE, MODEL, 4X4 OR 2WD, FULL SIZE OR S10, TUBE OR NO TUBE ON FRONT BRG. RET.

PART # NV4500 STYLE - (AKA MT8, MW3) 1991-ON C, K & P SERIES TRUCKS

MT-GM-NV4500-# **CORE - 30 DAYS**
 MT-GM-NV4500-A1 5 SPEED 2WD, 1992-94, C-TRUCK, GAS/DIESEL, TUBE STYLE FRONT RETAINER, ROUND TOP COVER
 MT-GM-NV4500-A2 5 SPEED 2WD, 1995, C-TRUCK, GAS/DIESEL, TUBE STYLE FRONT RETAINER, SQUARE TOP COVER
 MT-GM-NV4500-A3 5 SPEED 2WD, 1996-ON, C-TRUCK, GAS/DIESEL, FLAT ALUMINUM, FRONT RETAINER, SQUARE TOP COVER
 MT-GM-NV4500-B1 5 SPEED 4X4, 1992-94, K-TRUCK, GAS/DIESEL, TUBE STYLE FRONT RETAINER, ROUND TOP COVER
 MT-GM-NV4500-B2 5 SPEED 4X4, 1995, K-TRUCK, GAS/DIESEL, TUBE STYLE FRONT RETAINER, SQUARE TOP COVER
 MT-GM-MV4500-B3 5 SPEED 4X4, 1996-ON, K-TRUCK, GAS/DIESEL, FLAT ALUMINUM, FRONT RETAINER, SQUARE TOP COVER



GMC® REBUILT TRANSMISSIONS (cont.)

UNIT

PAGE

PART # NV4500 STYLE - (AKA MT8, MW3) 1991-ON C, K & P SERIES TRUCKS (cont.)

MT-GM-NV4500-C1	5 SPEED 2WD, 1992-94, GMT455, W/ E-BRAKE, TUBE STYLE FRONT RETAINER, ROUND TOP COVER
MT-GM-NV4500-C2	5 SPEED 2WD, 1995, GMT455, W/ E-BRAKE, TUBE STYLE FRONT RETAINER, SQUARE TOP COVER
MT-GM-NV4500-C3	5 SPEED 2WD, 1996-ON, GMT455, W/ E-BRAKE, FLAT ALUMINUM, FRONT RETAINER, SQUARE TOP COVER
MT-GM-NV4500-D1	5 SPEED 2WD, 1992-94, P-VAN, W/ E-BRAKE, TUBE STYLE FRONT RETAINER, ROUND TOP COVER
MT-GM-NV4500-D2	5 SPEED 2WD, 1995, P-VAN, W/ E-BRAKE, TUBE STYLE FRONT RETAINER, SQUARE TOP COVER
MT-GM-NV4500-D3	5 SPEED 2WD, 1996-ON, P-VAN, W/ E-BRAKE, FLAT ALUMINUM, FRONT RETAINER, SQUARE TOP COVER
MT-GM-NV4500-E1	5 SPEED 2WD, 1992-94, P-VAN, W/O E-BRAKE, TUBE STYLE FRONT RETAINER, ROUND TOP COVER
MT-GM-NV4500-E2	5 SPEED 2WD, 1995, P-VAN, W/O E-BRAKE, TUBE STYLE FRONT RETAINER, SQUARE TOP COVER
MT-GM-NV4500-E3	5 SPEED 2WD, 1996-ON, P-VAN, W/O E-BRAKE, FLAT ALUMINUM, FRONT RETAINER, SQUARE TOP COVER

WHAT WE NEED TO KNOW: YEAR, MAKE, MODEL, 4X4 OR 2WD, TAG # (IF POSSIBLE), CASTING # ON TAIL HOUSING

GMC® REBUILT TRANSFER CASES

PART # BW1370 / BW4401 STYLE - 1988-ON K3500

TC-GM-BW1370-#	CORE - 30 DAYS
TC-GM-BW1370-A	32 SPLINE INPUT, FIXED RR. OUTPUT, 3-POSITION SWITCH, 4" BELL FRONT OUTPUT YOKE, W/ PTO
TC-GM-BW1370-B	32 SPLINE INPUT, FIXED RR. OUTPUT, 2-POSITION SWITCH, 4" BELL FRONT OUTPUT YOKE, W/ PTO
TC-GM-BW1370-C	32 SPLINE INPUT, FRT & RR. FIXED OUTPUT YOKES, 3-POSITION SWITCH, W/ PTO
TC-GM-BW1370-D	32 SPLINE INPUT, SLIP RR. OUTPUT, 2-POSITION SWITCH, 4" BELL FRONT OUTPUT YOKE, W/ PTO
TC-GM-BW1370-E	32 SPLINE INPUT, SLIP RR. OUTPUT, 3-POSITION SWITCH, 4" BELL FRONT OUTPUT YOKE, W/ PTO
TC-GM-BW1370-F	33 SPLINE INPUT, SLIP RR. OUTPUT, 3-POSITION SWITCH, W/ PRO

WHAT WE NEED TO KNOW: YEAR, MAKE, MODEL, TAG#, PLUS ALL DESCRIPTION INFORMATION ABOVE

PART # BW4470 STYLE - 1988-ON K3500

TC-GM-BW4470-#	CORE - 30 DAYS
TC-GM-BW4470-A	32 SPLINE INPUT, FRONT & RR. FIXED YOKES, 3-POSITION SWITCH, W/ PTO
TC-GM-BW4470-B	32 SPLINE INPUT, FRONT & RR. FIXED YOKES, 2-POSITION SWITCH, W/ PTO
TC-GM-BW4470-C	32 SPLINE INPUT, RR. FIXED OUTPUT YOKE, 3-POSITION SWITCH, 4" BELL STYLE FRONT OUTPUT YOKE, W/ PTO
TC-GM-BW4470-D	32 SPLINE INPUT, RR. FIXED OUTPUT YOKE, 2-POSITION SWITCH, 4" BELL STYLE FRONT OUTPUT YOKE, W/ PTO
TC-GM-BW4470-E	32 SPLINE INPUT, RR. SLIP OUTPUT YOKE, 2-POSITION SWITCH, 4" BELL STYLE FRONT OUTPUT YOKE, W/ PTO

WHAT WE NEED TO KNOW: YEAR, MAKE, MODEL, TAG #, PLUS ALL DESCRIPTION DATA ABOVE

PART # BW4472 / BW1372 STYLE - 1991-98 ASTROVAN, SAFARI, BRAVADA, TYPHOON

TC-GM-BW4472-#	CORE - 30 DAYS
TC-GM-BW4472-A	CHEV, 4X4, 27 SPLINE REAR OUTPUT, 4.125" CENTERING RING
TC-GM-BW4472-B	CHEV, 4X4, 27 SPLINE REAR OUTPUT, 4.875" CENTERING RING
TC-GM-BW4472-C	CHEV, 4X4, 32 SPLINE REAR OUTPUT, 4.125" CENTERING RING
TC-GM-BW4472-D	CHEV, 4X4, 32 SPLINE REAR OUTPUT, 4.875" CENTERING RING

WHAT WE NEED TO KNOW: YEAR, MAKE, MODEL, TAG #, PLUS ALL DESCRIPTION INFORMATION ABOVE



GMC® REBUILT TRANSFER CASES (cont.)

UNIT

PAGE

PART # **BW4473 STYLE - EXPRESS 1500/2500**

TC-GM-BW4473-# CORE - 30 DAYS
 TC-GM-BW4473-A 27 SPLINE INPUT, RR. SLIP OUTPUT FEMALE SPLINE FRONT OUTPUT, AWD
 WHAT WE NEED TO KNOW: YEAR, MAKE, MODEL, TAG #

PART # **BW4481 STYLE - 2003-05 ESCALADE, EXT**

TC-GM-BW4481-# CORE - 30 DAYS
 TC-GM-BW4481-A 27 SPLINE INPUT, RR. SLIP OUTPUT FEMALE SPLINE FRONT OUTPUT, AWD
 WHAT WE NEED TO KNOW: YEAR, MAKE, MODEL, TAG #

PART # **NP126 STYLE - 2002-ON BRAVADA**

TC-GM-NP126-# CORE - 30 DAYS
 TC-GM-NP126-A 27 SPLINE INPUT, ELECTRIC SHIFT, SINGLE SPEED
 WHAT WE NEED TO KNOW: YEAR, MAKE, MODEL, TAG #

PART # **NP136 STYLE - 1998-ON PICK-UP**

TC-GM-NP136-# CORE - 30 DAYS
 TC-GM-NP136-CA CHEV. 4X4, 27 SPLINE INPUT (GET TAG #)
 WHAT WE NEED TO KNOW: YEAR, MAKE, MODEL, TAG #

PART # **NP149 STYLE - 2001-ON SIERRA, ESCALADE**

TC-GM-NP149-# CORE - 30 DAYS
 TC-GM-NP149-A 27 SPLINE INPUT, RR. SLIP OUTPUT YOKE, FEMALE FRONT OUTPUT, AWD
 WHAT WE NEED TO KNOW: YEAR, MAKE, MODEL, TAG #

PART # **NP203 STYLE - 1973-79 BLAZER, K SERIES**

TC-GM-NP203-# CORE - 30 DAYS
 TC-GM-NP203-CA USED W/ T350, DRIVER SIDE SPEEDO, NO PART TIME KIT
 TC-GM-NP203-CB USED W/ T350, DRIVER SIDE SPEEDO, W/ PART TIME KIT
 TC-GM-NP203-CC USED W/ T350, PASSENGER SIDE SPEEDO, NO PART TIME KIT
 TC-GM-NP203-CD USED W/ T350, PASSENGER SIDE SPEEDO, W/ PART TIME KIT
 TC-GM-NP203-CE USED W/ T400, DRIVER SIDE SPEEDO, NO PART TIME KIT
 TC-GM-NP203-CF USED W/ T400, DRIVER SIDE SPEEDO, W/ PART TIME KIT
 TC-GM-NP203-CG USED W/ T400, PASSENGER SIDE SPEEDO, NO PART TIME KIT
 TC-GM-NP203-CH USED W/ T400, PASSENGER SIDE SPEEDO, W/ PART TIME KIT
 TC-GM-NP203-CI USED W/ SM465, DRIVER SIDE SPEEDO, NO PART TIME KIT
 TC-GM-NP203-CJ USED W/ SM465, DRIVER SIDE SPEEDO, W/ PART TIME KIT
 TC-GM-NP203-CK USED W/ SM465, PASSENGER SIDE SPEEDO, NO PART TIME KIT
 TC-GM-NP203-CL USED W/ SM465, PASSENGER SIDE SPEEDO, W/ PART TIME KIT
 WHAT WE NEED TO KNOW: YEAR, MAKE, MODEL, PLUS ALL DESCRIPTION DATA ABOVE

PART # **NP205 STYLE - 1966-84 BLAZER K10-30 SERIES**

TC-GM-NP205-# CORE - 30 DAYS
 27 SPLINE INPUT (EXTERNAL SPLINE), SLIP RR. OUTPUT YOKE, USES "FIGURE 8" ADAPTER, MARRIED STYLE
 TC-GM-NP205-E 27 SPLINE INPUT (EXTERNAL SPLINE), FIXED RR. OUTPUT YOKE, USES "FIGURE 8" ADAPTER, MARRIED STYLE
 TC-GM-NP205-F 32 SPLINE INPUT (LONG VERSION), SLIP RR. OUTPUT, ROUND ADAPTER, MARRIED STYLE
 TC-GM-NP205-G 32 SPLINE INPUT (LONG VERSION), FIXED RR. OUTPUT, ROUND ADAPTER, MARRIED STYLE
 TC-GM-NP205-H 32 SPLINE INPUT (SHORT VERSION), SLIP RR. OUTPUT, ROUND ADAPTER, USES "FIGURE 8" ADAPTER, MARRIED STYLE
 TC-GM-NP205-I 32 SPLINE INPUT (SHORT VERSION), FIXED RR. OUTPUT, ROUND ADAPTER, USES "FIGURE 8" ADAPTER, MARRIED STYLE
 TC-GM-NP205-J 10 SPLINE INPUT (EXTERNAL SPLINE), FIXED FRONT & RR. YOKES, USES "FIGURE 8" ADAPTER WITH 2-SIDE MOUNTING HOLES, MARRIED STYLE
 TC-GM-NP205-K



GMC® REBUILT TRANSFER CASES (cont.)

UNIT

PAGE

PART # NP205 STYLE - 1966-84 BLAZER K10-30 SERIES (cont.)

TC-GM-NP205-L 10 SPLINE INPUT (EXTERNAL SPLINE), FIXED FRONT & RR. YOKES, USES "FIGURE 8" ADAPTER W/O 2-SIDE MOUNTING HOLES, MARRIED STYLE
 TC-GM-NP205-M 10 SPLINE INPUT (EXTERNAL SPLINE), SLIP RR. OUTPUT YOKES, USES "FIGURE 8" ADAPTER, MARRIED STYLE
WHAT WE NEED TO KNOW: YEAR, MAKE, MODEL, PLUS ALL DESCRIPTION INFORMATION ABOVE

PART # NP207 STYLE - 1983-87 BLAZER S10 JIMMY

TC-GM-NP207-# CORE - 30 DAYS
 27 SPLINE INPUT, 27 SPLINE RR. SLIP YOKE, FIXED FRONT OUTPUT, SPEEDO CABLE HOLE
WHAT WE NEED TO KNOW: YEAR, MAKE, MODEL

PART # NP208 STYLE - 1981-88 BLAZER, JIMMY

TC-GM-NP208-# CORE - 30 DAYS
 TC-GM-NP208-CA 27 SPLINE INPUT, 18 TOOTH BLUE SPEEDO, USED W/ 350-700 SERIES TRANSMISSION
 TC-GM-NP208-CB 27 SPLINE INPUT, 15T TAN/GREY SPEEDO, USED W/ 350-700 SERIES TRANSMISSION
 TC-GM-NP208-CC 32 SPLINE INPUT, 18 TOOTH BLUE SPEEDO, USED W/ 400 SERIES TRANSMISSION
 TC-GM-NP208-CD 32 SPLINE INPUT, 15T TAN/GREY SPEEDO, USED W/ 400 SERIES TRANSMISSION
WHAT WE NEED TO KNOW: YEAR, MAKE, MODEL

PART # NP226 STYLE - 2002-ON TRAILBLAZER (ELECTRIC SHIFT)

TC-GM-NP226-# CORE - 30 DAYS
 TC-GM-NP226-A 27 SPLINE INPUT, FRONT SLIP YOKE
WHAT WE NEED TO KNOW: YEAR, MAKE, MODEL, TAG #

PART # NP231 STYLE - 1988-ON S10, JIMMY

TC-GM-NP231-# CORE - 30 DAYS
 27 SPLINE INPUT, 27 SPLINE RR. SLIP OUTPUT, FIXED FRONT YOKE, SPEED SENSOR, WIRE OR VACUUM SHIFT INDICATOR
 TC-GM-NP231-CA EXT. CAB, 27 SPLINE INPUT, 32 SPLINE SLIP RR. YOKE, SLIP FRONT YOKE, SPEED SENSOR, WIRE OR VACUUM SHIFT INDICATOR, W/ TOP MOUNTING HOLES, FLAT SEAL RETAINER
 TC-GM-NP231-CB EXT. CAB, 27 SPLINE INPUT, 32 SPLINE SLIP RR. YOKE, SLIP FRONT YOKE, SPEED SENSOR, WIRE OR VACUUM SHIFT INDICATOR, W/ TOP MOUNTING HOLES, RAISED SEAL RETAINER
 TC-GM-NP231-CC EXT. CAB, 27 SPLINE INPUT, 32 SPLINE SLIP RR. YOKE, SLIP FRONT YOKE, SPEED SENSOR, WIRE OR VACUUM SHIFT INDICATOR, W/O TOP MOUNTING HOLES, FLAT SEAL RETAINER
 TC-GM-NP231-CD 27 SPLINE INPUT, 27 SPLINE RR. SLIP OUTPUT, FIXED FRONT YOKE, SPEED CABLE, WIRE OR VACUUM SHIFT INDICATOR
 TC-GM-NP231-CE EXT. CAB, 27 SPLINE INPUT, 32 SPLINE RR. SLIP OUTPUT, FIXED FRONT YOKE, WIRE OR VACUUM SHIFT INDICATOR, W/ TOP MOUNTING HOLES
WHAT WE NEED TO KNOW: YEAR, MAKE, MODEL, TAG #

PART # NP233 STYLE - 1992-ON, ELECTRIC SHIFT, S10, JIMMY

TC-GM-NP233-# CORE - 30 DAYS
 EXT. CAB. 27 SPLINE INPUT, 32 SPLINE RR. SLIP OUTPUT, SPEED SENSOR, FIXED FRONT YOKE, VACUUM SHIFT INDICATOR ABOVE ELECTRIC SHIFT, W/ TOP MOUNTING HOLES
 TC-GM-NP233-CA 27 SPLINE INPUT, 27 SPLINE RR. SLIP OUTPUT, SPEED SENSOR, FIXED FRONT YOKE, VACUUM SHIFT INDICATOR ABOVE ELECTRIC SHIFT
 TC-GM-NP233-CB EXT. CAB, 27 SPLINE INPUT, 32 SPLINE RR. SLIP OUTPUT, SPEED SENSOR, FIXED FRONT YOKE, VACUUM SHIFT INDICATOR ABOVE ELECTRIC SHIFT, NO TOP MOUNTING HOLES
 TC-GM-NP233-CC 27 SPLINE INPUT, 27 SPLINE RR. SLIP OUTPUT, SPEED SENSOR, SLIP FRONT YOKE, VACUUM SHIFT INDICATOR ABOVE ELECTRIC SHIFT
 TC-GM-NP233-CD EXT. CAB, 27 SPLINE INPUT, 32 SPLINE RR. SLIP OUTPUT, SPEED SENSOR, SLIP FRONT YOKE, VACUUM SHIFT INDICATOR, FLAT SEAL RETAINER
 TC-GM-NP233-CE EXT. CAB, 27 SPLINE INPUT, 32 SPLINE RR. SLIP OUTPUT, SPEED SENSOR, SLIP FRONT YOKE, VACUUM SHIFT INDICATOR, RAISED SEAL RETAINER
WHAT WE NEED TO KNOW: YEAR, MAKE, MODEL, TAG #



GMC® REBUILT TRANSFER CASES (cont.)

UNIT

PAGE

PART # **NP236 STYLE** - 1998-ON ELECTRIC SHIFT, ASTRO, SAFARI, GMC, BLAZER, ENVOY **WD**

TC-GM-NP236-# **CORE - 30 DAYS**
 TC-GM-NP236-A 27 SPLINE INPUT, RR. SLIP OUTPUT, SNAP RING ON FRONT OUTPUT
 TC-GM-NP236-B 27 SPLINE INPUT, RR. SLIP OUTPUT, MALE SPLINE FRONT OUTPUT, ELECTRIC SHIFT
WHAT WE NEED TO KNOW: YEAR, MAKE, MODEL, TAG #

PART # **NP241 STYLE** - 1987-98 BLAZER, SUBURBAN, TAHOE

TC-GM-NP241-# **CORE - 30 DAYS**
 TC-GM-NP241-CA 27 SPLINE INPUT, 2-WIRE INDICATOR, 4" BELL FRONT OUTPUT YOKE
 TC-GM-NP241-CB 32 SPLINE INPUT, 2-WIRE INDICATOR, 4" BELL FRONT OUTPUT YOKE
 TC-GM-NP241-CC 32 SPLINE INPUT, 3-WIRE INDICATOR, 4" BELL FRONT OUTPUT YOKE
 TC-GM-NP241-CD 27 SPLINE INPUT, 3-WIRE INDICATOR, 4" BELL FRONT OUTPUT YOKE
 TC-GM-NP241-CE 27 SPLINE INPUT, 2-WIRE INDICATOR, FIXED FRONT OUTPUT YOKE
 TC-GM-NP241-CF 32 SPLINE INPUT, 2-WIRE INDICATOR, FIXED FRONT OUTPUT YOKE, SPEED SENSOR
 TC-GM-NP241-CG 32 SPLINE INPUT, 2-WIRE INDICATOR, FIXED FRONT OUTPUT YOKE, 1.75" SPEEDO HOLE, RIGHT-HAND MOUNT
 TC-GM-NP241-CH 27 SPLINE INPUT, 3-WIRE INDICATOR, FIXED FRONT OUTPUT YOKE, SPEED SENSOR
 TC-GM-NP241-CI 32 SPLINE INPUT, 3-WIRE INDICATOR, FIXED FRONT OUTPUT YOKE
 TC-GM-NP241-CJ 32 SPLINE INPUT, 2-WIRE INDICATOR, 4" SQUARE FRONT OUTPUT YOKE, 2" SPEEDO HOLE, RIGHT-HAND MOUNT
 TC-GM-NP241-CK 27 SPLINE INPUT, 2-WIRE INDICATOR, 4" SQUARE FRONT OUTPUT YOKE, SPEED SENSOR, RIGHT-HAND MOUNT
 TC-GM-NP241-CL 32 SPLINE INPUT, 2-WIRE INDICATOR, 4" SQUARE FRONT OUTPUT YOKE, RIGHT-HAND MOUNT
 TC-GM-NP241-CM 27 SPLINE INPUT, 2-WIRE INDICATOR, 4" SQUARE FRONT OUTPUT YOKE, 2" SPEEDO HOLE, RIGHT-HAND MOUNT
WHAT WE NEED TO KNOW: YEAR, MAKE, MODEL, TAG #

PART # **NP243 STYLE** - 1996-ON BLAZER, SUBURBAN, TAHOE, YUKON

TC-GM-NP243-# **CORE - 30 DAYS**
 TC-GM-NP243-CA 27 SPLINE INPUT, U-JOINT TYPE FRONT YOKE - USED W/ 4L60E TRANSMISSION
 TC-GM-NP243-CB 32 SPLINE INPUT, U-JOINT TYPE FRONT YOKE - USED W/ 4L80E TRANSMISSION
 TC-GM-NP243-CC 27 SPLINE INPUT, FLANGE TYPE FRONT YOKE - USED W/ 4L60E TRANSMISSION
 TC-GM-NP243-CD 32 SPLINE INPUT, FLANGE TYPE FRONT YOKE - USED W/ 4L80E TRANSMISSION
WHAT WE NEED TO KNOW: YEAR, MAKE, MODEL, TAG #

PART # **NP246 STYLE** - 1998-ON ELECTRIC SHIFT, 1500/2500 SERIES STYLE TRUCKS

TC-GM-NP246-# **CORE - 30 DAYS**
 TC-GM-NP246-CA 27 SPLINE INPUT, FEMALE SPLINE FRONT OUTPUT
 TC-GM-NP246-CB 32 SPLINE INPUT, FEMALE SPLINE FRONT OUTPUT
 TC-GM-NP246-CC 27 SPLINE INPUT, FEMALE SPLINE FRONT OUTPUT, SPLINED SHIFT SECTOR
 TC-GM-NP246-CD 32 SPLINE INPUT, FEMALE SPLINE FRONT OUTPUT, SPLINED SHIFT SECTOR
WHAT WE NEED TO KNOW: YEAR, MAKE, MODEL, TAG #

PART # **NP261 STYLE** - 1999-ON MANUAL SHIFT, SILVERADO, 1500, 2500, 3500

TC-GM-NP261-# **CORE - 30 DAYS**
 TC-GM-NP261-CA 27 SPLINE INPUT, RR. SLIP OUTPUT, FEMALE SPLINE FRONT OUTPUT, (LD) - USED W/ 4L60 TRANSMISSION
 TC-GM-NP261-CB 32 SPLINE INPUT, RR. SLIP OUTPUT, FEMALE SPLINE FRONT OUTPUT, (LD) - USED W/ 4L80E TRANSMISSION
 TC-GM-NP261-CC 32 SPLINE INPUT, RR. SLIP OUTPUT, FEMALE SPLINE FRONT OUTPUT, (HD) - USED W/ 4L80E
 TC-GM-NP261-CD 29 SPLINE INPUT, RR. SLIP OUTPUT, 1.608" DIAMETER FEMALE SPLINE, FRONT OUTPUT, (XHD) - USED WITH ALLISON TRANSMISSION
WHAT WE NEED TO KNOW: YEAR, MAKE, MODEL, TAG #



GMC® REBUILT TRANSFER CASES (cont.)

UNIT

PAGE

PART # NP263 STYLE - 1999-ON ELECTRIC SHIFT SILVERADO, 1500, 2500, 3500, SAFARI

TC-GM-NP263-#	CORE - 30 DAYS 32 SPLINE INPUT, 32 SPLINE RR. SLIP, FEMALE FRONT OUTPUT (HD) - USED W/ 4L80E
TC-GM-NP263-CA	TRANSMISSION
TC-GM-NP263-CB	27 SPLINE INPUT, RR. SLIP MALE FRONT OUTPUT, (SAFARI 1999-05)
TC-GM-NP263-CC	29 SPLINE INPUT, 31 SPLINE RR. SLIP, FEMALE FRONT OUTPUT, (XHD) - USED W/ ALLISON TRANSMISSION

WHAT WE NEED TO KNOW: YEAR, MAKE, MODEL, TAG #

JEEP® REBUILT TRANSMISSIONS

PART # SR4 STYLE - 1979-81 CHEROKEE, WAGONEER, J10, J20

MT-JP-SR4-#	CORE - 30 DAYS
MT-JP-SR4-J	4 SPEED 4X4, 1979-81, CAST#: CAST #: "1332-xxx-xxx"

WHAT WE NEED TO KNOW: YEAR, MAKE, MODEL

PART # T4 STYLE - 1982-88 WRANGLER

MT-JP-T4-#	CORE - 30 DAYS
MT-JP-T4-C	4 SPEED 4X4, 14 SPLINE INPUT
MT-JP-T4-D	4 SPEED 4X4, 10 SPLINE INPUT

WHAT WE NEED TO KNOW: YEAR, MAKE, MODEL

PART # AX4 STYLE - 1984-87

MT-JP-AX4-#	CORE - 30 DAYS
MT-JP-AX4-A	4 SPEED 2WD, 1984-87, EXTERNAL SLAVE (NO SNOOT)
MT-JP-AX4-B	4 SPEED 2WD, 1984-87, INTERNAL SLAVE (W/ SNOOT)
MT-JP-AX4-C	4 SPEED 4X4, 1984-87, EXTERNAL SLAVE (NO SNOOT)
MT-JP-AX4-D	4 SPEED 4X4, 1984-87, WRANGLER, INTERNAL SLAVE (W/ SNOOT)
MT-JP-AX4-E	4 SPEED 4X4, 1984-87, CHEROKEE, INTERNAL SLAVE (NO SNOOT)

WHAT WE NEED TO KNOW: YEAR, MAKE, MODEL, 4X4 OR 2WD, TUBE OR NO TUBE ON FRT. BRG. RET.

PART # T5 STYLE - 1982-86 CJ5, CJ17, J10-20, CHEROKEE, WAGONEER

MT-JP-T5-#	CORE - 30 DAYS
MT-JP-T5-JA	5 SPEED 4X4, 10 SPLINE INPUT
MT-JP-T5-JB	5 SPEED 4X4, 14 SPLINE INPUT

WHAT WE NEED TO KNOW: YEAR, MAKE, MODEL, TAG #

PART # BA10 STYLE - 1987-90 CHEROKEE, COMANCHE, WRANGLER

MT-JP-BA10-#	CORE - 30 DAYS
MT-JP-BA10-A	5 SPEED 4X4, 1987-ON, WRANGLER
MT-JP-BA10-B	5 SPEED 4X4, 1987-ON, CHEROKEE
MT-JP-BA10-C	5 SPEED 2WD, 1987-ON

WHAT WE NEED TO KNOW: YEAR, MAKE, MODEL

PART # AX5 STYLE - 1984-98 CHEROKEE, COMANCHE, WRANGLER

MT-JP-AX5-#	CORE - 30 DAYS
MT-JP-AX5-A	5 SPEED 4X4, 1984-86, W/ NP207 TRANSFER CASE
MT-JP-AX5-B	5 SPEED 4X4, WRANGLER, 1984-86, INTERNAL SLAVE CYLINDER
MT-JP-AX5-C	5 SPEED 4X4, CHEROKEE, 1984-1986, INTERNAL SLAVE CYLINDER

continued →



JEEP® REBUILT TRANSMISSIONS (cont.)

UNIT

PAGE

PART # **AX5 STYLE** - 1984-98 CHEROKEE, COMANCHE, WRANGLER (cont.)

MT-JP-AX5-D 5 SPEED 4X4, WRANGLER, 1987-ON, EXTERNAL SLAVE CYLINDER
 MT-JP-AX5-E 5 SPEED 4X4, CHEROKEE, 1987-ON, EXTERNAL SLAVE CYLINDER
 MT-JP-AX5-F 5 SPEED 2WD, 1987-ON, EXTERNAL SLAVE CYLINDER
 MT-JP-AX5-G 5 SPEED 2WD, 1984-86, INTERNAL SLAVE CYLINDER

WHAT WE NEED TO KNOW: YEAR, MAKE, MODEL, 4X4 OR 2WD

PART # **AX15 STYLE** - 1984-98 CHEROKEE, COMANCHE, WRANGLER

MT-JP-AX15-# CORE - 30 DAYS
 MT-JP-AX15-A 5 SPEED 4X4, 1986 ONLY, .59 PILOT
 MT-JP-AX15-B 5 SPEED 4X4, CHEROKEE, 1986 ONLY, .59 PILOT
 MT-JP-AX15-C 5 SPEED 4X4, WRANGLER, 1987-91, .59 PILOT, INTERNAL SLAVE (TUBE)
 MT-JP-AX15-D 5 SPEED 4X4, CHEROKEE, 1987-91, .59 PILOT, INTERNAL SLAVE (TUBE)
 MT-JP-AX15-E 5 SPEED 4X4, WRANGLER, 1992-93, .750" PILOT, INTERNAL SLAVE (TUBE)
 MT-JP-AX15-F 5 SPEED 4X4, CHEROKEE, 1992-93, .750" PILOT, INTERNAL SLAVE (TUBE)
 MT-JP-AX15-G 5 SPEED 4X4, WRANGLER, 1994-ON, .750" PILOT, EXTERNAL SLAVE (NO TUBE)
 MT-JP-AX15-H 5 SPEED 4X4, CHEROKEE, 1994-ON, .750" PILOT, EXTERNAL SLAVE (NO TUBE)
 MT-JP-AX15-I 90-ON 2WD

WHAT WE NEED TO KNOW: YEAR, MAKE, MODEL, 4X4 OR 2WD

PART # **NV3550 STYLE** - 2000-04 CHEROKEE, WRANGLER TJ, RUBICON (TO '05)

MT-JP-NV3550-# CORE - 30 DAYS
 MT-JP-NV3550-A 5 SPEED 4X4,

WHAT WE NEED TO KNOW: YEAR, MAKE, MODEL

JEEP® REBUILT TRANSFER CASES

PART # **NP119 STYLE** - 1980-83 WRANGLER, CHEROKEE

TC-JP-NP119-# CORE - 30 DAYS
 TC-JP-NP119 GET TAG #

WHAT WE NEED TO KNOW: YEAR, MAKE, MODEL, TAG #

PART # **NP207 STYLE** - 1980-88 WRANGLER, CHEROKEE, J10

TC-JP-NP207-# CORE - 30 DAYS
 TC-JP-NP207-JA 21 SPLINE INPUT
 TC-JP-NP207-JB 23 SPLINE INPUT

WHAT WE NEED TO KNOW: YEAR, MAKE, MODEL, TAG #

PART # **NP208 STYLE** - 1983-88 WRANGLER, CHEROKEE

TC-JP-NP208-# CORE - 30 DAYS
 23 SPLINE INPUT, FRONT & RR. FIXED YOKES, SHIFT INDICATOR, 1.75" SPEEDO HOLE,
 TC-JP-NP208-JA LEFT HAND MOUNT
 23 SPLINE INPUT, FRONT & RR. FIXED YOKES, SHIFT INDICATOR, 1.75" SPEEDO HOLE,
 TC-JP-NP208-JB RIGHT HAND MOUNT

WHAT WE NEED TO KNOW: YEAR, MAKE, MODEL, TAG #

PART # **NP219 STYLE** - 1980-83 WAGONEER, CHEROKEE

TC-JP-NP219-# CORE - 30 DAYS
 TC-JP-NP219 GET TAG #

WHAT WE NEED TO KNOW: YEAR, MAKE, MODEL, TAG #



JEEP® REBUILT TRANSFER CASES (cont.)

UNIT

PAGE

PART # **NP228 STYLE - 1983-86 CHEROKEE, GRAND CHEROKEE, WAGONEER**

TC-JP-NP228-# CORE - 30 DAYS
 TC-JP-NP228-JA 23 SPLINE INPUT, FRONT AND RR. FIXED YOKES, SHIFT INDICATOR ON BACK HALF OF CASE
 TC-JP-NP228-JB 23 SPLINE INPUT, FRONT AND RR. FIXED YOKES, NO SHIFT INDICATOR
 WHAT WE NEED TO KNOW: YEAR, MAKE, MODEL, TAG #

PART # **NP229 STYLE - 1984-92 CHEROKEE, GRAND CHEROKEE, WAGONEER**

TC-JP-NP229-# CORE - 30 DAYS
 23 SPLINE INPUT, VISCOUS CLUTCH, 2 FIXED YOKES, 1.75" SPEEDO HOLE, HAS NO SHIFT INDICATOR IN CASE.
 TC-JP-NP229-JA 23 SPLINE INPUT, VISCOUS CLUTCH, 2 FIXED YOKES, 1.75" SPEEDO HOLE, HAS 2-WIRE SHIFT INDICATOR ON BACK HALF OF CASE.
 TC-JP-NP229-JB 23 SPLINE INPUT, VISCOUS CLUTCH, 2 FIXED YOKES, 1.75" SPEEDO HOLE, HAS 2-WIRE SHIFT INDICATOR ON BACK HALF OF CASE.
 WHAT WE NEED TO KNOW: YEAR, MAKE, MODEL, TAG #

PART # **NP231 STYLE - 1988-ON COMANCHE, CHEROKEE, GRAND CHEROKEE, WAGONEER**

TC-JP-NP231-# CORE - 30 DAYS
 23 SPLINE INPUT, 2 PC. TAIL HOUSING, FIXED FRONT YOKE, 2-WIRE SHIFT INDICATOR ABOVE SHIFT LEVER, 1.75" SPEEDO HOLE, .75" EXPOSED INPUT SHAFT
 TC-JP-NP231-JA 23 SPLINE INPUT, 1 PC. TAIL HOUSING W/ RUBBER BOOT, FIXED FRONT YOKE, 2-WIRE SHIFT INDICATOR ABOVE SHIFT LEVER, .84" EXPOSED INPUT SHAFT
 TC-JP-NP231-JB 23 SPLINE INPUT, 1 PC. TAIL HOUSING W/ RUBBER BOOT, FIXED FRONT YOKE, 2-WIRE SHIFT INDICATOR ABOVE SHIFT LEVER, 1.55" EXPOSED INPUT SHAFT
 TC-JP-NP231-JC 21 SPLINE INPUT, 2 PC. TAIL HOUSING WITH 1.75" SPEEDO HOLE, FIXED FRONT YOKE, 2-WIRE SHIFT INDICATOR ABOVE SHIFT LEVER, .75" EXPOSED INPUT SHAFT
 TC-JP-NP231-JD 21 SPLINE INPUT, 2 PC. TAIL HOUSING WITH 1.75" SPEEDO HOLE, FIXED FRONT YOKE, VACUUM SHIFT INDICATOR ON SPEEDO HOUSING, .75" EXPOSED INPUT SHAFT
 TC-JP-NP231-JE 23 SPLINE INPUT, 2 PC. TAIL HOUSING WITH 1.75" SPEEDO HOLE, FIXED FRONT YOKE, 2-WIRE SHIFT INDICATOR ABOVE SHIFT LEVER, .75" EXPOSED INPUT SHAFT
 TC-JP-NP231-JF 21 SPLINE INPUT, 1 PC. TAIL HOUSING W/ RUBBER BOOT, FIXED FRONT YOKE, 2-WIRE SHIFT INDICATOR ABOVE SHIFT LEVER, .75" EXPOSED INPUT SHAFT
 TC-JP-NP231-JG 23 SPLINE INPUT, 2 PC. TAIL HOUSING W/ 1.75" SPEEDO HOLE, FIXED FRONT YOKE, 4-WIRE SHIFT INDICATOR ABOVE SHIFT LEVER, .84" EXPOSED INPUT SHAFT W/ PILOT BUSHING
 TC-JP-NP231-JH 23 SPLINE INPUT, 2 PC. TAIL HOUSING W/ 1.75" SPEEDO HOLE, FIXED FRONT YOKE, 4-WIRE SHIFT INDICATOR ABOVE SHIFT LEVER, .75" EXPOSED INPUT SHAFT
 TC-JP-NP231-JI 23 SPLINE INPUT, 2 PC. TAIL HOUSING W/ 1.75" SPEEDO HOLE, FIXED FRONT YOKE, 2-WIRE SHIFT INDICATOR, 1.55" EXPOSED INPUT SHAFT
 TC-JP-NP231-JJ 23 SPLINE INPUT, 1 PC. TAIL HOUSING W/ RUBBER BOOT AND HARMONIC BALANCER, 2-WIRE SHIFT INDICATOR, 1.55" EXPOSED INPUT SHAFT
 TC-JP-NP231-JK 23 SPLINE INPUT, 1 PC. TAIL HOUSING W/ RUBBER BOOT AND HARMONIC BALANCER, 2-WIRE SHIFT INDICATOR, 1.55" EXPOSED INPUT SHAFT
 WHAT WE NEED TO KNOW: YEAR, MAKE, MODEL, TAG #

PART # **NP242 STYLE (SELECT TRAC) 1988-ON CHEROKEE, GRAND CHEROKEE, WAGONEER**

TC-JP-NP242-# CORE - 30 DAYS
 21 SPLINE INPUT, 2 PC. TAIL HOUSING, FIXED FRONT YOKE, 4-WIRE SHIFT INDICATOR ON SHIFT TAIL HOUSING, .75" EXPOSED INPUT SHAFT
 TC-JP-NP242-JA 23 SPLINE INPUT, 1 PC. TAIL HOUSING W/ RUBBER BOOT, FIXED FRONT YOKE, 4-WIRE SHIFT INDICATOR ABOVE SHIFT LEVER, .84" EXPOSED INPUT SHAFT
 TC-JP-NP242-JB 23 SPLINE INPUT, 2-PC. TAIL HOUSING WITH 1.75" SPEEDO HOLE, FIXED FRONT YOKE, 4-WIRE SHIFT INDICATOR ON SPEEDO HOUSING, .84" EXPOSED INPUT SHAFT
 TC-JP-NP242-JC 23 SPLINE INPUT, 2 PC. TAIL HOUSING W/O SPEEDO HOLE, W/ RUBBER BOOT, CUP FRONT YOKE, 4-WIRE SHIFT INDICATOR ABOVE SHIFT LEVER, .75" EXPOSED INPUT SHAFT
 TC-JP-NP242-JD 23 SPLINE INPUT, 2 PC. TAIL HOUSING WITH 1.75" SPEEDO HOLE, FIXED FRONT YOKE, 4-WIRE SHIFT INDICATOR, .75" EXPOSED INPUT SHAFT
 TC-JP-NP242-JE 23 SPLINE INPUT, 2 PC. TAIL HOUSING, WITH 1.75" SPEEDO HOLE, FIXED FRONT YOKE, 4-WIRE SHIFT INDICATOR ABOVE SHIFT LEVER, .84" EXPOSED INPUT SHAFT W/ PILOT BUSHING
 TC-JP-NP242-JF 23 SPLINE INPUT, 2 PC. TAIL HOUSING, WITH 1.75" SPEEDO HOLE, FIXED FRONT YOKE, 4-WIRE SHIFT INDICATOR ABOVE SHIFT LEVER, .84" EXPOSED INPUT SHAFT W/ PILOT BUSHING
 WHAT WE NEED TO KNOW: YEAR, MAKE, MODEL, TAG #



JEEP® REBUILT TRANSFER CASES (cont.)

UNIT

PAGE

PART # NP247 STYLE - 1999-ON GRAND CHEROKEE

TC-JP-NP247-# CORE - 30 DAYS
 TC-JP-NP247-JA 23 SPLINE INPUT, 27 SPLINE RR. SLIP OUTPUT, CUP STYLE FRONT OUTPUT YOKE, VISCOUS DRIVE
 TC-JP-NP247-JB 23 SPLINE INPUT, 27 SPLINE RR. SLIP OUTPUT, CUP STYLE FRONT OUTPUT YOKE, QUADRA-TRAC
 WHAT WE NEED TO KNOW: YEAR, MAKE, MODEL, TAG #

PART # NP249 STYLE - 1993-ON CHEROKEE, GRAND CHEROKEE, WAGONEER

TC-JP-NP249-# CORE - 30 DAYS
 TC-JP-NP249-A QUADRA-TRAC, 23 SPLINE INPUT, VISCOUS CLUTCH, .84" EXPOSED INPUT SHAFT
 TC-JP-NP249-B QUADRA TRAC, 23 SPLINE INPUT, VISCOUS CLUTCH, 1.55" EXPOSED INPUT SHAFT
 TC-JP-NP249-C 23 SPLINE INPUT, VISCOUS CLUTCH, .84" EXPOSED INPUT SHAFT W/ PILOT BUSHING
 WHAT WE NEED TO KNOW: YEAR, MAKE, MODEL, TAG #

PART # NP251 STYLE

TC-JP-NP251-# CORE - 30 DAYS
 TC-JP-NP251-A GET TAG #
 WHAT WE NEED TO KNOW: YEAR, MAKE, MODEL, TAG #

REBUILT IMPORT TRANSMISSIONS

ISUZU® - REBUILT

PART # MSG-5ET STYLE - 1984-6/87 TROOPER

MT-ISU-MSG-5ET# CORE - 30 DAYS
 MT-ISU-MSG-5ETA 5 SPEED 4X4, 1984-87, ALUMINUM CASE, IRON TAIL, GAS, 5T SPEEDO
 MT-ISU-MSG-5ETB 5 SPEED 4X4, 1984-87, ALUMINUM CASE, IRON TAIL, DIESEL, 5T SPEEDO
 MT-ISU-MSG-5ETC 5 SPEED 4X4, 1984-87, ALUMINUM CASE, IRON TAIL, GAS, 6T SPEEDO
 MT-ISU-MSG-5ETD 5 SPEED 4X4, 1984-87, ALUMINUM CASE, IRON TAIL, DIESEL, 6T SPEEDO
 WHAT WE NEED TO KNOW: YEAR, MAKE, MODEL, PLUS ALL DESCRIPTION DATA ABOVE

PART # MSG-5F STYLE - 1987-ON RODEO, TROOPER, AMIGO

MT-ISU-MSG-5F-# CORE - 30 DAYS
 MT-ISU-MSG-5F-A 5 SPEED 4X4, 5T SPEEDO, REAR SLIP YOKE W/ TRANSFER CASE
 MT-ISU-MSG-5F-B 5 SPEED 4X4, 6T SPEEDO, REAR SLIP YOKE W/ TRANSFER CASE
 MT-ISU-MSG-5F-C 5 SPEED 4X4, REMOTE SHIFT, 5T SPEEDO, REAR SLIP YOKE
 MT-ISU-MSG-5F-D 5 SPEED 4X4, REMOTE SHIFT, 6T SPEEDO, REAR SLIP YOKE
 MT-ISU-MSG-5F-E 5 SPEED 4X4, V6, 5T SPEEDO, REAR SLIP YOKE
 MT-ISU-MSG-5F-F 5 SPEED 4X4, V6, 6T SPEEDO, REAR SLIP YOKE
 MT-ISU-MSG-5F-G 5 SPEED 4X4, REMOTE SHIFT, V6, 5T SPEEDO, REAR SLIP YOKE
 MT-ISU-MSG-5F-H 5 SPEED 4X4, REMOTE SHIFT, V6, 6T SPEEDO, REAR SLIP YOKE
 MT-ISU-MSG-5F-I 5 SPEED 4X4, REMOTE SHIFT, V6, 5T SPEEDO, BOLT ON YOKE
 MT-ISU-MSG-5F-J 5 SPEED 4X4, REMOTE SHIFT, V6, 6T SPEEDO, BOLT ON YOKE
 WHAT WE NEED TO KNOW: YEAR, MAKE, MODEL, PLUS ALL DESCRIPTION DATA ABOVE

PART # NV1500 STYLE - 1996-ON HOMBRE

MT-ISU-NV1500-# CORE - 30 DAYS
 MT-ISU-NV1500 5 SPEED 2WD, 1996-ON ISUZU, HOMBRE, ALUMINUM CASE AND TAIL, CAST # 22340
 WHAT WE NEED TO KNOW: YEAR, MAKE, MODEL



REBUILT IMPORT TRANSMISSIONS (cont.)

UNIT

PAGE

ISUZU® - REBUILT (cont.)

PART # T5 STYLE - 1990-ON RODEO

MT-ISU-T5-# CORE - 30 DAYS
 MT-ISU-T5-IA 5 SPEED 2WD, ISUZU RODEO, CAST # 1352-2", 2.6L, 4 CYL., 14 SPLINE INPUT
 MT-ISU-T5-IB 5 SPEED 2WD, ISUZU RODEO, CAST # 1352-2", 2.6L, 4 CYL., 24 SPLINE INPUT
 WHAT WE NEED TO KNOW: YEAR, MAKE, MODEL, INPUT SPLINE COUNT

MAZDA® - REBUILT

PART # B2000 STYLE - 1997-84 B2000

MT-MAZ-B2000-# CORE - 30 DAYS
 MT-MAZ-B2000 5 SPEED 2WD
 WHAT WE NEED TO KNOW: YEAR, MAKE, MODEL, SPEEDO COLOR

PART # B2200 STYLE - 1986-97 B2200

MT-MAZ-B2200-# CORE - 30 DAYS
 MT-MAZ-B2200-A 5 SPEED 2WD, 1986-93
 MT-MAZ-B2200-B 5 SPEED 2WD, 1994-97
 WHAT WE NEED TO KNOW: YEAR, MAKE, MODEL, SPEEDO COLOR

NISSAN® - REBUILT

PART # FS5R30 STYLE - 1985-ON HARDBODY

MT-NIS-FS5R30-# CORE - 30 DAYS
 MT-NIS-FS5R30-A 5 SPEED 4X4, 1986-96, TRUCK, 6 CYL. DIRECT MOUNT TO TRANSFER CASE
 5 SPEED 4X4, 1996-ON, TRUCK, 6 CYL. DIRECT MOUNT TO TRANSFER CASE, CRANK
 POSITION SENSOR ON BELL
 MT-NIS-FS5R30-B 5 SPEED 2WD, 1986-ON, TRUCK, 6 CYL.
 MT-NIS-FS5R30-C 5 SPEED 2WD, 1986-ON, TRUCK, 6 CYL.
 MT-NIS-FS5R30-D 5 SPEED 2WD, 9/86-ON, CAR, TURBO/NON-TURBO 6 CYL. 300ZX
 WHAT WE NEED TO KNOW: YEAR, MAKE, MODEL, PLUS ALL DESCRIPTION INFORMATION ABOVE

PART # FS5W71 STYLE - 1985-ON HARDBODY

MT-NIS-FS5W71-# CORE - 30 DAYS
 MT-NIS-FS5W71-B 5 SPEED 2WD, 1974-80, 4 CYL. 16" TAIL HOUSING
 MT-NIS-FS5W71-C 5 SPEED 2WD, 1981-86, 4 CYL. 16" TAIL HOUSING
 MT-NIS-FS5W71-D 5 SPEED 2WD, 1981-86, DIESEL
 MT-NIS-FS5W71-E 5 SPEED 2WD, 1986-95, 4 CYL. 6 BOLT SHIFTER
 MT-NIS-FS5W71-F 5 SPEED 4X4, 1981-86, 12" TAIL HOUSING
 MT-NIS-FS5W71-G 5 SPEED 4X4, 1986-95, 4 CYL. DIRECT MOUNT TO TRANSFER CASE
 MT-NIS-FS5W71-H 5 SPEED 2WD, 1996-ON, 4 CYL. CRANK POSITION SENSOR ON BELL
 MT-NIS-FS5W71-I 5 SPEED 4X4, 1996-ON, 4 CYL. CRANK POSITION SENSOR ON BELL
 MT-NIS-FS5W71-J 5 SPEED CAR, 1983-89, CAR, NON-TURBO V6, 300ZX
 WHAT WE NEED TO KNOW: YEAR, MAKE, MODEL, PLUS ALL DESCRIPTION DATA ABOVE



REBUILT IMPORT TRANSMISSIONS (cont.)

UNIT

PAGE

SUZUKI® - REBUILT

PART # SAM STYLE - 1986-ON SAMURAI

MT-SUZUKI-# CORE - 30 DAYS
MT-SUZUKI-SAM 5 SPEED 4X4
WHAT WE NEED TO KNOW: YEAR, MAKE, MODEL

TOYOTA® - REBUILT

PART # L42 STYLE - 1972-74 PICK-UP

MT-TOY-L42-# CORE - 30 DAYS
MT-TOY-L42-A 4 SPEED, 1972-8/74, 21 SPLINE REAR OUTPUT
WHAT WE NEED TO KNOW: YEAR, MAKE, MODEL

PART # L43 STYLE - 1974-80 PICK-UP

MT-TOY-L43-# CORE - 30 DAYS
MT-TOY-L43 4 SPEED 4X4, 8/74-1980
WHAT WE NEED TO KNOW: YEAR, MAKE, MODEL

PART # L52 STYLE - 1980-84 PICK-UP

MT-TOY-L52-# CORE - 30 DAYS
MT-TOY-L52-A 5 SPEED 4X4, 1980-83, ALUMINUM TOP COVER
MT-TOY-L52-B 5 SPEED 2WD, 1980-83, GAS
MT-TOY-L52-C 5 SPEED 2WD, 1980-83, DIESEL
WHAT WE NEED TO KNOW: YEAR, MAKE, MODEL

PART # G52 STYLE - 1983-88 PICK-UP

MT-TOY-G52-# CORE - 30 DAYS
MT-TOY-G52-A 5 SPEED 4X4, 1984-ON, 4 CYL. CARBURATED MOTOR
MT-TOY-G52-B 5 SPEED 2WD, 1984-ON, 4 CYL. CARBURATED MOTOR
WHAT WE NEED TO KNOW: YEAR, MAKE, MODEL

PART # R150 STYLE - 1986-ON T100, TACOMA, 4RUNNER

MT-TOY-R150-# CORE - 30 DAYS
MT-TOY-R150 5 SPEED 2WD, 1985-ON, V6 OR 4 CYL. (TURBO)
WHAT WE NEED TO KNOW: YEAR, MAKE, MODEL

PART # R151 STYLE - 1986-ON T100, TACOMA, 4RUNNER

MT-TOY-R151-# CORE - 30 DAYS
MT-TOY-R151-A 5 SPEED 4X4, 1989-94, V6, 4 CYL. (TURBO)
MT-TOY-R151-B 5 SPEED 4X4, 1995-ON, V6
MT-TOY-R151-C 5 SPEED 4X4, 1986-88, 4 CYL. (TURBO)
MT-TOY-R151-D 5 SPEED 4X4, 1995-ON, T100, V6
WHAT WE NEED TO KNOW: YEAR, MAKE, MODEL, ENGINE SIZE

PART # W50 STYLE - 1974-86 PICK-UP

MT-TOY-W50-# CORE - 30 DAYS
MT-TOY-W50-A 5 SPEED 2WD, 1974-86, 5/8" SPROCKET, STRAIGHT UP SHIFTER STICK TIP
MT-TOY-W50-B 5 SPEED 2WD, 1974-86, 3/4" SPROCKET, STRAIGHT UP SHIFTER STICK TIP
MT-TOY-W50-C 5 SPEED 2WD, 1974-86, SHIFTER HANGS OVER REAL SEAL
WHAT WE NEED TO KNOW: YEAR, MAKE, MODEL, PLUS ALL DESCRIPTION DATA ABOVE



REBUILT IMPORT TRANSMISSIONS (cont.)

TOYOTA® - REBUILT (cont.)

UNIT

PAGE

PART # W55 STYLE - 1983-ON PICK-UP

MT-TOY-W55-# CORE - 30 DAYS
MT-TOY-W55-A 5 SPEED 2WD, 1981-88, PICK-UP AND SOME TOYOTA CARS
MT-TOY-W55-B 5 SPEED 2WD, 1989-ON, PICK-UP ONLY
WHAT WE NEED TO KNOW: YEAR, MAKE, MODEL

PART # W56 STYLE - 1984-93 PICK-UP

MT-TOY-W56-# CORE - 30 DAYS
MT-TOY-W56-A 5 SPEED 4X4, 1984-ON, FUEL INJECTED, 1 SHIFTER STICK
MT-TOY-W56-B 5 SPEED 4X4, 9/88-ON, FUEL INJECTED, 2 SHIFTER STICKS
WHAT WE NEED TO KNOW: YEAR, MAKE, MODEL, NUMBER OF SHIFTER STICKS

PART # W59 STYLE

MT-TOY-W59-# CORE - 30 DAYS
MT-TOY-W59-A 5 SPEED 4X4, 1995-ON, TACOMA, 4 CYL.
MT-TOY-W59-B 5 SPEED 2WD, 1995-ON, TACOMA, 4 CYL.
WHAT WE NEED TO KNOW: YEAR, MAKE, MODEL, NUMBER OF SHIFTER STICKS



Motive Gear supplies manual transmission and transfer case components such as gearing, bearings, seals, gaskets and more! Motive Gear also supplies rebuild kits, transmission case parts, plus new and rebuilt manual transmissions.

- ▶ Easy installation
- ▶ Unmatched durability
- ▶ Comprehensive warranty



TABLE OF CONTENTS

	PAGE
AMC® 20 STYLE	.8
CHRYSLER® 7.25" STYLE	.8-9
CHRYSLER® 8.0" FRONT STYLE	.9
CHRYSLER® & JEEP® 8.25" & 8.375" STYLE	.10
CHRYSLER® 8.75" 741 EARLY STYLE	.10-11
CHRYSLER® 8.75" 742 EARLY STYLE	.11-12
CHRYSLER® 8.75" LATE 489 STYLE	.12
CHRYSLER® 9.25" IFS FRONT STYLE	.13
CHRYSLER® 9.25" REAR STYLE	.13-14
CHRYSLER® 10.5" 14 BOLT REAR STYLE	.14
CHRYSLER® 11.5" 14 BOLT REAR STYLE	.15
DANA® 30 STYLE	.16
DANA® 35 & 35 IFS STYLE	.17
DANA® 44 STYLE	.18-19
DANA® 50 STYLE	.19-20
DANA® 60 STYLE	.21
DANA® 70 STYLE	.22-23
DANA® 80 STYLE	.24
FORD® 7.5" STYLE	.25
FORD® 8" STYLE	.26
FORD® 8.8" STYLE	.27
FORD® 9" STREET GEARS STYLE 1957 & UP	.28
FORD® 9" PERFORMANCE STYLE 1957 & UP	.28
FORD® 9" PERFORMANCE STYLE "AX" SERIES - LIGHT WEIGHT RACING APP'S	.29
FORD® 9" STYLE PRO GEARS	.30
FORD® 9.75" STYLE	.31
FORD® 10.25" STYLE EARLY 1983-1992	.32
FORD® 10.25" STYLE LATE 1993-1999	.32
FORD® 10.5" STYLE 1999 & LATER	.33
GM® 7.2" STYLE	.33-34
GM® 7.5" & 7.625" STYLE	.34-35
GM® 7.60" IFS FRONT STYLE	.35
GM® 7.75" BORG WARNER® STYLE	.36
GM® 8.0" STYLE	.36
GM® 8.20" 10 BOLT STYLE 1955-1964 CAR	.37
GM® 8.20" BUICK®/OLDS®/PONTIAC® STYLE	.38
GM® 8.20" 10 BOLT STYLE 1964-1972 CAR	.38-39
GM® CORVETTE® STYLE 1963-1979	.39
GM® CORVETTE® STYLE 1997 & LATER	.40
GM® 8.25" IFS STYLE FRONT	.40-41
GM® 8.5" 10 BOLT FRONT & REAR / 8.6" 10 BOLT REAR STYLE	.41-42
GM® 8.875" 12 BOLT STYLE CAR	.43

TABLE OF CONTENTS

	PAGE
GM® 8.875" 12 BOLT STYLE TRUCK	44
GM® 9.25" IFS 14 BOLT STYLE - FRONT	44-45
GM® 9.5" 14 BOLT STYLE - REAR	45
GM® 10.5" 14 BOLT STYLE	46
GM® 11.5" STYLE	47
TOYOTA® 7.5" IFS STYLE	47
TOYOTA® 7.8" STYLE	48
TOYOTA® 7.8" V6 AND TURBO STYLE	48
TOYOTA® LANDCRUISER® - FRONT IFS STYLE	49
TOYOTA® LANDCRUISER® STYLE	49
TOYOTA® TACOMA® & T100™ REAR STYLE	50
TOYOTA® TACOMA® - FRONT STYLE	50
GEAR RATIO CHART	51
LIGHT DUTY AXLE SHAFTS	54-63
MINI & FULL SPOOLS, NODULAR HOUSINGS, PINION SUPPORTS	66-67
PINION YOKES & ASSOCIATED COMPONENTS	68-71
CASES & INTERNAL PARTS KITS	72-82
RING GEAR SPACERS	82
PERFORMANCE GEAR OIL - LIMITED SLIP	82
ARB AIR LOCKER® MANUAL LOCKING DIFFERENTIALS	84-93
AUBURN GEAR® ASSEMBLIES	94-96
EATON® POSI LIMITED SLIP DIFFERENTIALS	98-104
SUPERWINCH® & WARN® HUBS	106-107
MANUAL TRANSMISSION & TRANSFER CASE EXPERTS	110
TROUBLESHOOTING RING & PINIONS	112-114

MOTIVE GEAR® KITS & WHAT THEY INCLUDE:

DIFFERENTIAL BEARING KIT:

FRONT & REAR PINION BEARING, PINION SEAL, CARRIER BEARINGS, PILOT BEARING WHERE APPLICABLE, GEAR MARKING COMPOUND, CRUSH SLEEVE, PINION NUT, BRUSH, THREAD LOCKING COMPOUND AND COVER GASKET OR RTV.

ADD "T" TO END OF PART # FOR ALL TIMKEN® BEARING KITS.

DIFFERENTIAL MASTER BEARING KIT:

DIFFERENTIAL BEARING KIT PLUS RING GEAR BOLTS, PINION SHIMS, CARRIER SHIMS

ADD "T" TO END OF PART# FOR ALL TIMKEN® BEARING KITS.

RING & PINION KIT:

RING & PINION

RING & PINION MASTER KIT:

RING & PINION AND DIFFERENTIAL MASTER BEARING KIT.

ADD "T" TO END OF PART# FOR ALL TIMKEN® BEARING KITS.

MINI INSTALLATION KIT:

PINION SHIMS, CARRIER SHIMS, PINION NUT, RING GEAR BOLTS, GEAR MARKING COMPOUND, PINION SEAL, CRUSH SLEEVE, BRUSH, AND COVER GASKET OR RTV.

INTERNAL KIT (OPEN):

SIDE GEARS, SIDE GEAR WASHERS, PINION GEARS, PINION GEAR WASHERS, PINION SHAFT AND LOCK BOLT OR ROLL PIN.

INTERNAL KIT (POSI):

SIDE GEARS, SIDE GEAR WASHERS, PINION GEARS, PINION GEAR WASHERS, PINION SHAFT, PINION BLOCK WHERE APPLICABLE, LOCK BOLT OR ROLL PIN, CLUTCHES OR POSI PLATES AND RETAINERS WHERE APPLICABLE.

KEY

 = NEW PART NUMBER

MotiveGear
Performance®

Motive
Gear®

LEAD WITH POWER

Dominate the track with AX Series ring & pinions from Motive Gear Performance. Rigorous testing and innovative technology elevates the AX Series to CHAMPION level power, durability, and performance.

- ▶ Solid Shank Pinion Shaft
- ▶ Indexed Tooth Spacing
- ▶ CNC Start to Finish
- ▶ Computerized Heat Treatment
- ▶ 2 lbs of rotating weight eliminated with the AX Series!
- ▶ Central Contact Pattern
- ▶ Gleason 5 Cut Technology
- ▶ Cutting Edge Lapping

**Motive Gear
Performance®**

AX



Motive Gear Performance
Proudly Sponsors Warren Johnson



Ring & Pinions / Bearing Kits



RING & PINION PART NUMBER KEY FOR:



Example: Part # D36-375 ICA REFERS TO

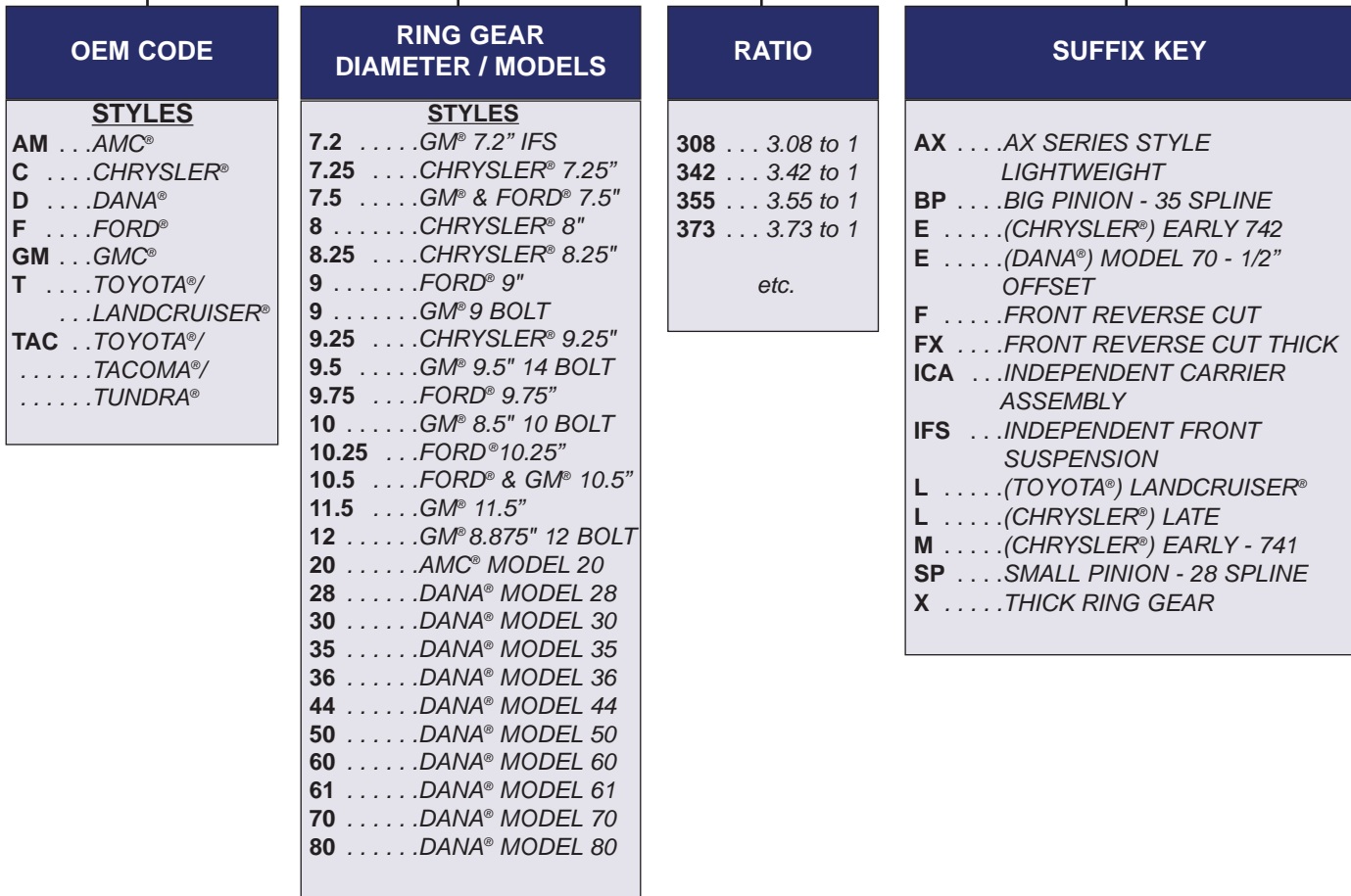

MotiveGear Performance®

Example: Part # G885410 REFERS TO

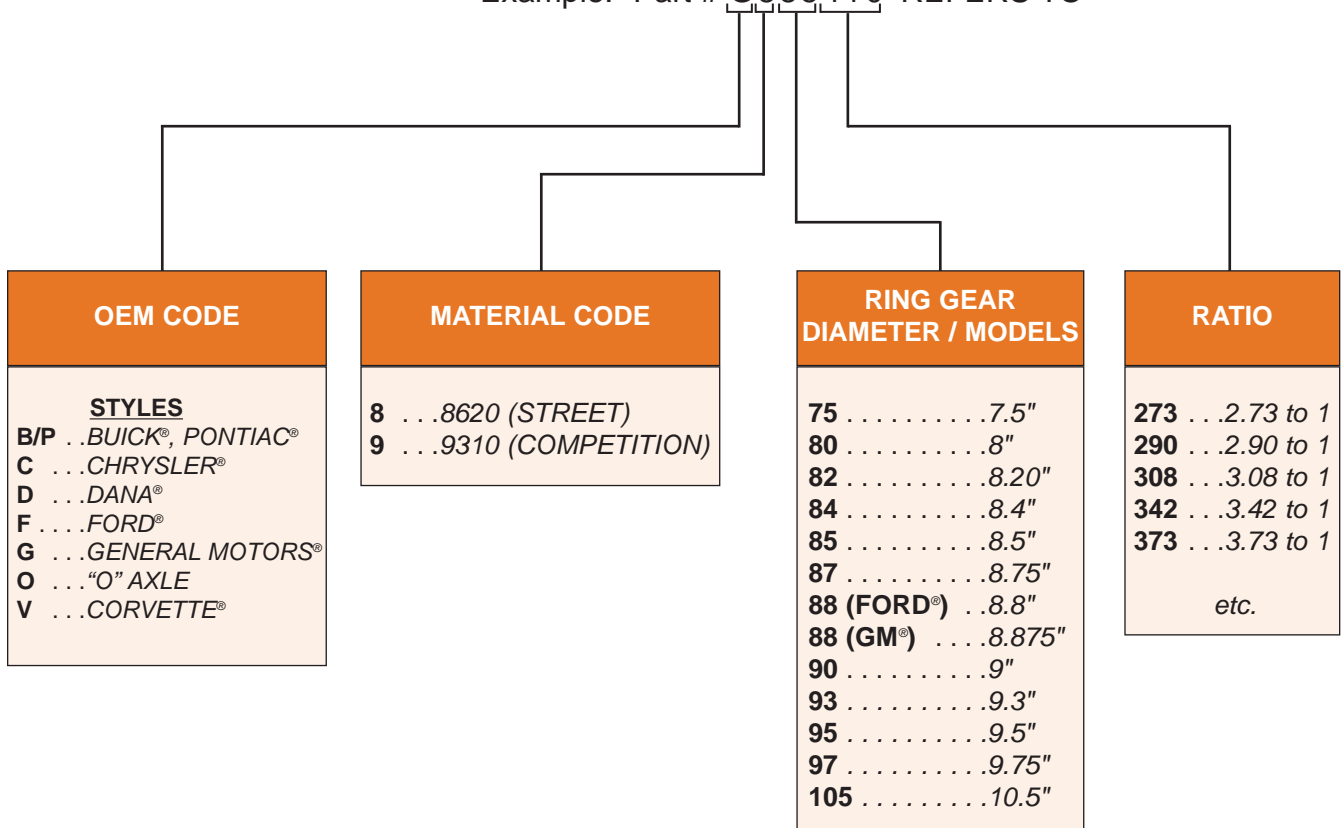

AMC® 20 STYLE

MODEL#	YEAR	MODEL#	YEAR
AMBASSADOR	68-74	MARLIN	69
AMX	68-79	MATADOR	72-78
CONCORD	78-79	PACER V8	78-79
GREMLIN V8	70-76	RAMBLER	69
HORNET V8	73-77	REBEL	69
J10	80-86	SCRAMBLER	76-86
JAVELIN V8	70-74	SPIRIT V8	79
JEEP® CJ	74-86	WAGONEER	79-86

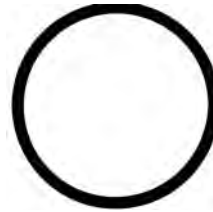

10-1/32" X 10-25/64"
12 HOLES
ROUND

SPECIFICATIONS:

- RG DIAMETER 8.875"
 - 8 7/16" X 20 RH THREADED BOLTS
 - PINION DIAMETER 1.625" 28 SPLINES
 - CASES: 2.73 & NUMERICALLY LOWER
3.08 & NUMERICALLY HIGHER
- 8620 Material - Heat Treated

MOTIVE GEAR® R&P			
MG#	OEM REF#	TEETH	RATIO
AM20-331	8132700	43-13	3.31
AM20-354	4486825	39-11	3.54
AM20-373	8133179	41-11	3.73
AM20-410	8127072	41-10	4.10
AM20-456	8124410	41-9	4.56
AM20-488	N/A	39-8	4.88

AMC® 20 STYLE INSTALLATION KITS & KIT COMPONENTS

DESCRIPTION	INSTALLATION KIT NO.	BEARING KIT NO.	MASTER KIT NO.	SUPER KIT NO.
1964 - 1988	AM20IK	R20R R20RT*	R20RMK R20RMKT*	
12 BOLT 8.875" HUMMER® STYLE		R20RH		

*KIT CONTAINS TIMKEN® BEARINGS

PINION SHIMS	CARRIER SHIMS	CRUSH SLEEVE	PINION SEAL	PINION NUT	RING GEAR BOLT	COVER GASKET
1127	1130	3507575	470331N	379570S	D8OZ4216B	5123

CHRYSLER® 7.25" STYLE

MODEL#	YEAR	MODEL#	YEAR
ASPEN	76-80	FIFTH AVENUE	80-89
CHALLENGER	70-76	IMPERIAL	77-89
CHARGER	70-71	LEBARON	75-83
CORDOBA	75-83	MIRADA	77-82
DAKOTA (F)	87-96	NEW YORKER	77-89
DAKOTA (R)	87-96	NEWPORT	77-89
DART	66-72	ST. REGIS	77-83
DIPLOMAT	77-89		



9-1/8"
9 HOLES
IRREGULAR

CHRYSLER® 7.25" STYLE (CONT.)

MOTIVE GEAR® R&P			
MG#	OEM REF#	TEETH	RATIO
C7.25-355	4411971	39-11	3.55
C7.25-390	4504006	39-10	3.90
C7.25-410		41-10	4.10

SPECIFICATIONS:

- RG DIAMETER 7.25"
- 8 3/8" x 24 LH THREADED BOLTS
- PINION DIAMETER 1.375" 27 SPLINES
- CASES: 2.47 & NUMERICALLY LOWER
2.76 & NUMERICALLY HIGHER
- 8620 Material - Heat Treated

CHRYSLER® 7.25" STYLE INSTALLATION KITS & KIT COMPONENTS

DESCRIPTION	INSTALLATION KIT NO.	BEARING KIT NO.	MASTER KIT NO.	SUPER KIT NO.
1960-ON	C7.25IK	R7.25R R7.25RT*	R7.25RMK R7.25RMKT*	

*KIT CONTAINS TIMKEN® BEARINGS

PINION SHIMS	CARRIER SHIMS	CRUSH SLEEVE	PINION SEAL	PINION NUT	RING GEAR BOLT	COVER GASKET
1104	N/A	3507575	8516N	1260823	1304	5127

CHRYSLER® 8.0" FRONT STYLE

MODEL	YEAR
DODGE® DURANGO (F)	2000 - ON
DODGE® DAKOTA	2000 - ON
TRUCK 1/2 TON R1500 (F)	2002 - ON



10-3/8"
12 HOLES
IRREGULAR

MOTIVE GEAR PERFORMANCE® R&P		
MGP#	TEETH	RATIO
C8-391	39-10	3.91
C8-410	41-10	4.10
C8-456	41-9	4.56

SPECIFICATIONS:

- RG DIAMETER 7 9/16"
- 8 3/8 X 24 RH THREADED BOLTS
- PINION DIAMETER 1.406 26 SPLINES
- CASE 3.31 & DOWN - 3.54 & UP
- 8620 Material - Heat Treat

CHRYSLER 8.0" FRONT STYLE INSTALLATION KITS & KIT COMPONENTS

DESCRIPTION	INSTALLATION KIT NO.	BEARING KIT NO.	MASTER KIT NO.	SUPER KIT NO.
RAM STYLE ONLY	R8IK	RC8R RC8RT*	RC8RMK RC8RMKT*	

*KIT CONTAINS TIMKEN® BEARINGS

PINION SHIMS	CARRIER SHIMS	CRUSH SLEEVE	PINION SEAL	PINION NUT	RING GEAR BOLT	COVER GASKET
1100	N/A	3507678	52070457AA	1260823	1304	107276

CHRYSLER® & JEEP® 8.25" & 8.375" STYLE

MODEL#	YEAR	MODEL#	YEAR	MODEL#	YEAR	MODEL#	YEAR
PASSENGER		CHALLENGER	70-74	DART	72-76	MIRADA/MAGNUM	78-83
CARS, VARIOUS	73-97	CHARGER/CORONET	73-76	DIPLOMAT/LEBARON	77-83	NEWORT	72-73
B100, 150, 200, 250	69-ON	CHEROKEE	97-01	DURANGO	98-ON	NEW YORKER	72-88
B,D,W-100	66-97	CHRYSLER®	87-ON	DUSTER	73-76	POLAR/SATELLITE	70-74
B,D,W-200	66-97	CHRYSLER 300	72-79	FIFTH AVE.	80-89	ST. REGIS	79-81
B,D,W-300	66-97	CORDOBA	75-83	FURY	70-81	W100, 150	86-ON
ASPEN/VOLARE	76-80	DAKOTA	87-ON	IMPERIAL	71-83	TRUCK 1/2 TON	69-96
BARRACUDA	70-74	DAKOTA	90-97	LIBERTY	02-ON	TRUCK 1/2 TON RAM	97-ON

MOTIVE GEAR® R&P			
MG#	OEM REF#	TEETH	RATIO
C8.25-271	3837580	46-17	2.71
C8.25-294	3837581	47-16	2.94
C8.25-321	3837582	45-14	3.21
C8.25-355	3837583	39-11	3.55
C8.25-390	3837584	39-10	3.90
C8.25-410		41-10	4.10
C8.25-456		41-9	4.56



11-3/8"
10 HOLES
OVAL

SPECIFICATIONS:

- RG DIAMETER 8.25"
 - 10 3/8" X 24 LH THREADED BOLTS
 - PINION DIAMETER 1.626" 27 SPLINES
 - CASE: 2.71 & NUMERICALLY HIGHER
- 8620 Material - Heat Treated

CHRYSLER® & JEEP® 8.25" & 8.375" STYLE INSTALLATION KITS & KIT COMPONENTS

DESCRIPTION	INSTALLATION KIT NO.	BEARING KIT NO.	MASTER KIT NO.	SUPER KIT NO.
1972-ON	C8.25IK	R8.25R R8.25RT*	R8.25RMK R8.25RMKT*	R8.25RSK R8.25RSKT*

*KIT CONTAINS TIMKEN® BEARINGS

PINION SHIMS	CARRIER SHIMS	CRUSH SLEEVE	PINION SEAL	PINION NUT	RING GEAR BOLT	COVER GASKET
1100	N/A	3507575	8516N	1260823	1304	5131

CHRYSLER® 8.75" EARLY (741)STYLE

MODEL#	YEAR	MODEL#	YEAR
B200/B250	65-68	FURY/IMPERIAL/	
BARRACUDA	64-68	TOWN & COUNTRY	57-68
BELVIDERE/300	57-68	ROAD RUNNER/	
CHARGER (DAYTON)	66-68	SATELLITE	67-68
CONCORD/MONACO/		SUPER BEE	68
POLARA	63-68	VALIANT	60-68
DART/SWINGER	66-68	W100/2150	65-68

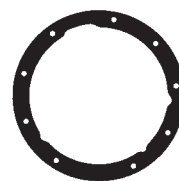

8-11/16" X 10-19/32"
10 HOLES
ROUND

CHRYSLER® 8.75" EARLY (741) STYLE (CONT.)

MOTIVE GEAR PERFORMANCE® R&P		
MGP#	TEETH	RATIO
C887355M	39-11	3.55
C887373M	41-11	3.73
ORIGINAL DESIGN WAS 10 SPLINE. MOTIVE GEAR® R&P ARE 29 SPLINE. MUST ORDER 29 SPLINE PINION YOKE. PLEASE SEE PINION YOKE SECTION ON PAGE 68.		

SPECIFICATIONS:

- 10 BOLT THIRD MEMBER
- RG DIAMETER 8.75"
- 12 3/8" X 24 LH THREADED BOLTS
- PINION DIAMETER 1.375" 29 SPLINES
- 741 STYLE CASTING • STRAIGHT PINION
- CASE: NO CASE BREAKS
- 8620 Material - Heat Treated

CHRYSLER® 8.75" EARLY (741) STYLE INSTALLATION KITS & KIT COMPONENTS

DESCRIPTION	INSTALLATION KIT NO.	BEARING KIT NO.	MASTER KIT NO.	SUPER KIT NO.
741 STYLE CASTING	C8.75IKM	R8.75RM R8.75RMT*	R8.75RMMK R8.75RMMKT*	
741 STYLE CASTING	C8.75IKM	R8.75RMA R8.75RMAT*	R8.75RMAMK R8.75RMAMKT*	

*KIT CONTAINS TIMKEN® BEARINGS

PINION SHIMS	CARRIER SHIMS	CRUSH SLEEVE	PINION SEAL	PINION NUT	RING GEAR BOLT	COVER GASKET
1109	N/A	1107A	5126B	1260823	1304	5101

CHRYSLER® 8.75" EARLY (742) STYLE

MODEL#	YEAR	MODEL#	YEAR
B200/B250	65-68	NEW YORKER	57-68
BARRACUDA	64-68	NEWPORT	57-68
BELVIDERE/300	57-68	ROAD RUNNER/	
CHALLENGER	68	SATELLITE	68
CHARGER (DAYTON)	66-68	SUPER BEE	68
CONCORD/MONACO/		TRUCK 1/2 TON	57-68
POLARA/CORONET	63-68	TRUCK 3/4 TON	65-68
DART/SWINGER	66-68	VALIANT	60-68
FURY/IMPERIAL/		W100/2150	65-68
TOWN & COUNTRY	57-68		



8-11/16" X 10-19/32"
10 HOLES
ROUND

MOTIVE GEAR PERFORMANCE® R&P		
MGP#	TEETH	RATIO
■ C887373E	41-11	3.73
■ C887391E	48-11	3.91
■ C887410E	41-10	4.10
■ C887456E	32-7	4.57

SPECIFICATIONS:

- 10 BOLT THIRD MEMBER
- RG DIAMETER 8.75"
- 12 3/8" X 24 LH THREADED BOLTS
- PINION DIAMETER 1.750" 10 SPLINES
- 742 STYLE CASTING • STRAIGHT PINION
- CASE: NO CASE BREAKS
- 8620 Material - Heat Treated

SEE INSTALLATION KITS
& KIT COMPONENTS ON
NEXT PAGE



CHRYSLER® 8.75" EARLY (742) STYLE (CONT.)

CHRYSLER® 8.75" EARLY (742) STYLE INSTALLATION KITS & KIT COMPONENTS

DESCRIPTION	INSTALLATION KIT NO.	BEARING KIT NO.	MASTER KIT NO.	SUPER KIT NO.
742 STYLE CASTING 1955-1960 W/SURE GRIP, POWER LOCK & OPEN STYLE	C8.75IKE	R8.75ER R8.75ERT*	R8.75ERMK R8.75ERMKT*	
742 CASTING 1955-1960 W/SPOOL & AUBURN® STYLE	C8.75IKE	R8.75ERS R8.75ERST*	R8.75ERSMK R8.75ERSMKT*	

*KIT CONTAINS TIMKEN® BEARINGS

PINION SHIMS	CARRIER SHIMS	CRUSH SLEEVE	PINION SEAL	PINION NUT	RING GEAR BOLT	COVER GASKET
1108	N/A	1107	7216	1260823	1304	5101

CHRYSLER® 8.75" LATE (489) STYLE

MODEL	YEAR	MODEL	YEAR	MODEL	YEAR	MODEL	YEAR
B200-B250	69-74	CHRYSLER® 300	69-73	IMPERIAL/		ROADRUNNER	74-93
BARRACUDA/		CORONET	69	TOWN & COUNTRY	69-74	SUPER BEE	69-70
CHARGER (DAYTONA)	69-74	DART/SWINGER	69-72	MONACO/POLARA	69-74	TRUCK 1/2 TON	68-74
BELVIDERE	69-70	DUSTER	70-74	NEWPORT/ NEW YORKER	69-74	TRUCK 3/4 TON	69-74
CHALLENGER	69-74	FURY/VALIANT	69-74	SATELLITE	69-74	W100/W150	69-74

MOTIVE GEAR PERFORMANCE® R&P

MGP#	TEETH	RATIO
C887355L	39-11	3.55
C887373L	41-11	3.73
C887391L	48-11	3.91
■ C887410L	41-10	4.10
■ C887456L	41-9	4.56



8-11/16" X 10-19/32"
10 HOLES
ROUND

SPECIFICATIONS:

- 10 BOLT THIRD MEMBER
- 489 STYLE CASTING# • TAPERED PINION
- RG DIAMETER 8.75"
- 12 3/8" X 24 LH THREADED BOLTS
- PINION DIAMETER 1.875" 29 SPLINES
- CASES: NO CASE BREAKS
- 8620 Material - Heat Treated

CHRYSLER® 8.75" LATE (489) STYLE INSTALLATION KITS & KIT COMPONENTS

DESCRIPTION	INSTALLATION KIT NO.	BEARING KIT NO.	MASTER KIT NO.	SUPER KIT NO.
489 CASTING 1960-1974 W/SURE GRIP & POWER LOCK	C8.75IKL	R8.75RL R8.75RLT*	R8.75RLMK R8.75RLMKT*	
489 CASTING 1960-1974 W/OPEN OR AUBURN®	C8.75IKL	R8.75RLA R8.75RLAT*	R8.75RLAMK R8.75RLAMKT*	

*KIT CONTAINS TIMKEN® BEARINGS

PINION SHIMS	CARRIER SHIMS	CRUSH SLEEVE	PINION SEAL	PINION NUT	RING GEAR BOLT	COVER GASKET
1102	N/A	3102	5126B	1260823	1304	5101

CHRYSLER® 9.25" IFS FRONT STYLE

MODEL	YEAR
-------	------

DODGE® RAM 2500, 3500 2003-ON



10-3/16 X 11-3/16"
10 HOLES
ROUND

MOTIVE GEAR® R&P			
MG#	OEM REF#	TEETH	RATIO
■ C9.25-373F			3.73
■ C9.25-410F			4.10

SPECIFICATIONS:

- 114 BOLT COVER
- RG DIAMETER 9.25"
- 12 - M12 X 1.5 RH THREADED BOLTS
- PINION DIAMETER 1.875" 30 SPLINES
- CASES: NO CASE BREAKS

CHRYSLER® 9.25" IFS FRONT STYLE INSTALLATION KITS & KIT COMPONENTS

DESCRIPTION	INSTALLATION KIT NO.	BEARING KIT NO.	MASTER KIT NO.	SUPER KIT NO.
2003-ON DODGE® RAM 2500, 3500 14 BOLT FRONT	GM9.5IKL	R9.5GRL R9.5GRLT*	R9.5GRLMK R9.5GRLMKT*	

*KIT CONTAINS TIMKEN® BEARINGS

PINION SHIMS	CARRIER SHIMS	CRUSH SLEEVE	PINION SEAL	PINION NUT	RING GEAR BOLT	COVER GASKET
1102	GM9.5SSK	14012691	26064029	1260823	14012703	5126

CHRYSLER® 9.25" REAR STYLE

MODEL	YEAR	MODEL	YEAR	MODEL	YEAR	MODEL	YEAR
B350	84-ON	DURANGO	98-ON	NEWPORT	73-81	TRUCK 1/2 TON	74-ON
CHARGER	74-76	FIFTH AVENUE	80-81	NEW YORKER	72-81	TRUCK 3/4 TON	74-ON
CORDOBA	75-81	FURY	73-81	POLARA	70-74	TRUCK 1 TON	74-2000
D300/D350	74-ON	IMPERIAL	74-75	RAMCHARGER	74-93	W100/W150/W200/W250	74-ON
DAKOTA W/V8	98-ON	MONACO	75-85	TRAILDUSTER	74-ON		

MOTIVE GEAR® R&P			
MG#	OEM REF#	TEETH	RATIO
C9.25-321	3837594	45-14	3.21
C9.25-355	3837595	39-11	3.55
C9.25-390	3837596	39-10	3.90
C9.25-410		41-10	4.10
C9.25-456		41-9	4.56

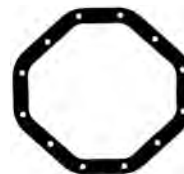

12-3/8" X 11-1/2"
12 HOLES
IRREGULAR PATTERN

SPECIFICATIONS:

- RG DIAMETER 9.25"
 - 12 7/16" X 18 LH THREADED BOLTS
 - PINION DIAMETER 1.876" 29 SPLINES
 - CASE: 2.71 & NUMERICALLY HIGHER
- 8620 Material - Heat Treated

**SEE INSTALLATION KITS
& KIT COMPONENTS ON
NEXT PAGE**



CHRYSLER® 9.25" REAR STYLE (CONT.)

CHRYSLER® 9.25" REAR STYLE INSTALLATION KITS & KIT COMPONENTS

DESCRIPTION	INSTALLATION KIT NO.	BEARING KIT NO.	MASTER KIT NO.	SUPER KIT NO.
12 BOLT 1969-2000	C9.25IK	R9.25R R9.25RT*	R9.25RMK R9.25RMKT*	R9.25RSK R9.25RSKT*
2001-ON		R9.25RL R9.25RLT*	R9.25RLMK R9.25RLMKT*	

*KIT CONTAINS TIMKEN® BEARINGS

PINION SHIMS	CARRIER SHIMS	CRUSH SLEEVE	PINION SEAL	PINION NUT	RING GEAR BOLT	COVER GASKET
1102	N/A	3507678	5126B	1260823	14066913	5132

CHRYSLER® 10.5" 14 BOLT REAR STYLE

MODEL	YEAR
DODGE® RAM P/U 2500 & 3500 SERIES	2003-ON

MOTIVE GEAR® R&P			
MG#	OEM REF#	TEETH	RATIO
■ C10.5-373			3.73
■ C10.5-410			4.10

SPECIFICATIONS:

- 14 BOLT COVER
- RG DIAMETER 10.5"
- 12 M14X1.5 LH THREADED BOLTS
- PINION DIAMETER 1.75" 30 SPLINES
- CASE: NO CASE BREAKS

CHRYSLER® 10.5" 14 BOLT REAR STYLE INSTALLATION KITS & KIT COMPONENTS

DESCRIPTION	INSTALLATION KIT NO.	BEARING KIT NO.	MASTER KIT NO.	SUPER KIT NO.
2003-ON DODGE® RAM 2500, 3500 14 BOLT REAR	GM10.5IKLA GM10.5IKLA-2	R14RLA R14RLAT*	R14RLAMKH R14RLAMKHT* R14RLAMKL R14RLAMKLT*	

*KIT CONTAINS TIMKEN® BEARINGS

PINION SHIMS	CARRIER SHIMS	CRUSH SLEEVE	PINION SEAL	PINION NUT	RING GEAR BOLT	COVER GASKET
GM14SK	N/A	3977355	N/A	15994582	331421	3977387

CHRYSLER® 11.5" 14 BOLT REAR STYLE

MODEL	YEAR
DODGE® RAM P/U 3500 SERIES	2003-ON

MOTIVE GEAR® R&P			
MG#	OEM REF#	TEETH	RATIO
■ C11.5-373			3.73
■ C11.5-410			4.10

SPECIFICATIONS:

- 14 BOLT COVER
- RG DIAMETER 11.5"
- 12 M14 X1.5 LH THREADED BOLTS
- PINION DIAMETER 2" 30 SPLINES
- CASE: NO CASE BREAKS

CHRYSLER® 11.5" 14 BOLT REAR STYLE INSTALLATION KITS & KIT COMPONENTS

DESCRIPTION	INSTALLATION KIT NO.	BEARING KIT NO.	MASTER KIT NO.	SUPER KIT NO.
2003-ON DODGE® RAM 2500	C11.5IK	R11.5R R11.5RT*	R11.5CRMK R11.5CRMKT*	

*KIT CONTAINS TIMKEN BEARINGS

PINION SHIMS	CARRIER SHIMS	CRUSH SLEEVE	PINION SEAL	PINION NUT	RING GEAR BOLT	COVER GASKET
1111	N/A	12471647	26064030	40003027	40022812	107276



TEAM MOTIVE GEAR

DANA® 30 STYLE

MODEL	YEAR
AMC® EAGLE FRT	87-87-1/2
BRONCO & U100	67-71
EXPLORER	2001-ON
FORD® AEROSTAR	87-89-1/2
GRAND CHEROKEE WJ	99-ON
GRAND CHEROKEE ZJ	92-96
IHC® SCOUT F	67-75
JEEPSTER	72-73

MODEL	YEAR
JEEP® C101 F&R	67-74
JEEP® CJ5,CJ7F & CJ8	74-86
JEEP® J10 F	66-71
JEEP® WAGONEER F	72-73
JEEP® CHEROKEE XJ	84&UP
JEEP® WRANGLER TJ	97&UP
JEEP® WRANGLER YJ	87-96
LIBERTY TRUCK	2002-ON

SPECIFICATIONS:

- RG DIAMETER 7.20"
 - 10 3/8" X 20 RH THREADED BOLTS
 - PINION DIAMETER 1.376" 26 SPLINES
 - CASE: 3.55 & NUMERICALLY LOWER 3.73 & NUMERICALLY HIGHER
- 8620 Material - Heat Treated

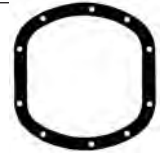

9-1/8" X 8-3/4"
10 HOLES
OVAL

R&P SUITABLE FOR DANA®				
MG#	OEM REF# REAR	OEM REF# FRONT	TEETH	RATIO
D30 STYLE REVERSE FRONT				
706930-2X		706930-2X	43-14	3.07
D30-373F		706930-5X	41-11	3.73
D30-410F		706930-4X	41-10	4.10
D30-456F		706930-6X	41-9	4.56
D30-488F			39-8	4.88
MG#	OEM REF# REAR	OEM REF# FRONT	TEETH	RATIO
D30 STYLE STRAIGHT CUT FRONT & REAR				
D30-354		706503-2X	46-13	3.54
D30-373	706000-3X	706503-3X	41-11	3.73
D30-410	706000-4X	706503-4X	41-10	4.10
■ 706000-8X	706000-8X		47-11	4.27
D30-456			41-9	4.56
D30-488			39-8	4.88
■ 70289-5X	70289-5X		43-8	5.38

DANA®/SPICER® kit includes ring & pinion, gasket, pinion bearings, bolts, seal and shims, pinion nut and washer.

Ring & Pinion also available separately. MOTIVE GEAR® Part # ring & pinion only.

R&P SUITABLE FOR DANA®				
MG#	OEM REF# REAR	OEM REF# FRONT	TEETH	RATIO
D30 STYLE TJ FRONT W/COLLAPSIBLE SPACER SHORT PINION				
■ 707344-2X		707344-2X	43-14	3.07
■ 707344-10X		707344-10X	39-11	3.55
D30-373TJ		707344-11X	41-11	3.73
D30-410TJ		707344-6X	41-10	4.10
D30-456TJ			41-9	4.56
D30-488TJ			39-8	4.88
MG#	OEM REF# REAR	OEM REF# FRONT	TEETH	RATIO
D30 STYLE NON-TJ FRONT W/COLLAPSIBLE SPACER				
■ 707300-4X		707300-4X	39-11	3.55
■ 707300-5X		707300-5X	41-11	3.73
D30-410*		706503-4X	41-10	4.10
D30-456*			41-9	4.56
D30-488*			39-8	4.88

*When using these gear sets to replace D30 style Front W/Collapsible spacer, use standard D30 style bearing kit and do not use crush sleeve.

DANA® 30 STYLE INSTALLATION KITS & KIT COMPONENTS

DESCRIPTION	INSTALLATION KIT NO.	BEARING KIT NO.	MASTER KIT NO.	SUPER KIT NO.
TJ STYLE	D30IK	R30FR R30FRT*	R30FRMK R30FRMKT*	
TJ STYLE	D30IKTJ	R30LR R30LRT*	R30LRMK R30LRMKT*	
IFS 1966-1990 FORD & JEEP	D30IK	R30R R30RT*	R30RMK R30RMKT*	
FRONT TJ ALL/WJ STYLE 1997-ON FORD® EXPLORER STYLE 2001-ON		R30LRA R30LRAT*	R30LRAMK R30LRAMKT*	

*KIT CONTAINS TIMKEN® BEARINGS

DESCRIPTION	PINION SHIMS	CARRIER SHIMS	CRUSH SLEEVE	PINION SEAL	PINION NUT	RING GEAR BOLT	COVER GASKET
DANA® 30 STYLE (F&R)	1112	1116	1114	5778	30185	41221	5113
1997-ON	1112	1116	44228	5778	30185	41221	5113
	1112	1116	1114	5778	30185	41221	5113

DANA® 35 & 35 IFS STYLE

MODEL#	YEAR
AMX	80-88
BRONCO II	90-92
CHEROKEE	81-01
COMANCHE XJ	85-ON
CONCORD	80-88
DAKOTA (F)	97-99
DURANGO (F)	97-99
EAGLE	80-88
EXPLORER	
SPORT TRAC	2001-ON

MODEL#	YEAR
FORD® EXPLORER	90-1/2-ON
GRAND CHEROKEE WJ	99-ON
GRAND CHEROKEE ZJ	93-ON
LIBERTY	2002-ON
PACER	80-88
RANGER (F)	98-ON
RANGER 4.0L	90-97
SPIRIT	80-88
WAGONEER	84-90
WRANGLER TJ, YJ (R)	90-2002

DANA® 35 STYLE



9-3/8" X 10-1/4"
10 HOLES
OVAL

DANA® 35 IFS STYLE



10-3/8"
12 HOLES
IRREGULAR

R&P SUITABLE FOR DANA®				
MG#	OEM REF# REAR	OEM REF# FRONT	TEETH	RATIO
D30 STYLE TJ FRONT W/COLLAPSIBLE SPACER				
■ 707244-1X*	707244-1X*		43-14	3.07
D35-355	707244-3X*		39-11	3.55
D35-373	707244-8X*		41-11	3.73
■ 73404-5X~		73404-5X~	41-10	4.10
D35-411	707244-4X*		37-9	4.11
D35-456F			41-9	4.56
D35-456	707244-5X*		41-9	4.56
D35-488			39.8	4.88
MOTIVE GEAR® Part# is ring & pinion only.				
* DANA®/ SPICER® kit includes ring & pinion, gasket, pinion bearings, bolts, seal and shims, pinion nut & washer.				
~ Reverse spiral bevel. Front IPS application only.				

SPECIFICATIONS:

- RG DIAMETER 7.562"
 - 8 7/16" X 20 RH THREADED BOLTS
 - PINION DIAMETER 1.376" 26 SPLINES
 - CASES: 2.35
2.73-3.31
3.54 & NUMERICALLY HIGHER
- 8620 Material - Heat Treated

NOTE: WHILE WE HAVE MADE EVERY EFFORT TO INCLUDE HELPFUL APPLICATION NOTES, WE RECOMMEND YOU SPECIFY BILL OF MATERIAL WHEN ORDERING.

DANA® 35 & 35 IFS STYLE INSTALLATION KITS & KIT COMPONENTS

DESCRIPTION	INSTALLATION KIT NO.	BEARING KIT NO.	MASTER KIT NO.	SUPER KIT NO.
IFS STYLE 1990-ON (FORD® ONLY)	D35IKF	R35FR R35FRT*	R35FRMK R35FRMKT*	
1964-ON (JEEP® ONLY)	D35IKJ	R35JR R35JRT*	R35JRMK R35JRMKT*	
WJ - 1999-ON	D35IKJ	R35RW R35RWT*	R35RWMK R35RWMKT*	

*KIT CONTAINS TIMKEN® BEARINGS

PINION SHIMS	CARRIER SHIMS	CRUSH SLEEVE	PINION SEAL	PINION NUT	RING GEAR BOLT	COVER GASKET
1112	1125R	3507575	470331N	44189	41221	107276

DANA® 44 STYLE

MODEL#	YEAR
BRONCO (F)	67-96
BRONCO II (F)	80-82
JEEP® CHEROKEE (F)	78-85
JEEP® CHEROKEE (R)	77-80
GRAND CHEROKEE WJ	99-ON
CHEVROLET®	60-80
CHEVROLET® K30, 35 (F)	67-76
CHEVROLET® C10,5 (R)	60-70
CHRYSLER® W100, 150, 200, 300 & 350 (F)	69-ON
CHRYSLER® 1/2 TON (F)	69-93
DODGE® 1/2 TON RAM (F)	94-ON

MODEL#	YEAR
CHRYSLER® 3/4 TON (F)	69-84
DODGE® 3/4 TON RAM (F)	94-ON
COBRA	63-67
CORVETTE®	80-83
CORVETTE® W/ MANUAL TRANSMISSION	85-96
FIREBIRD	84-85
FIREBIRD	92-94
FORD® F100, F50, 4X4 (R)	67-78
FORD® F150 (F)	75-78
FORD® F250 (F)	77-90
FORD® F100 & F150 (F)	78-90

MODEL#	YEAR
FORD® 1/2 TON (F)	67-96
FORDv 1/2 TON (R)	67-79
FORD® 3/4 TON (F)	67-88
FORD® 1 TON (F)	81-85
GM® 1/2 TON (F)	69-80
GM® 1/2 TON (R)	65-72
GM® 3/4 TON (F)	68-80
IHC® SCOUT (F)	72-80
IHC® SCOUT (R)	68-80
IHC® 100, 150, 200, 1100, 1110, 1200, 1210 (F&R)	65-75
JEEP® C101 (R)	67-72

MODEL#	YEAR
JEEP® J10, J20 (F)	78-87
JEEP® CJ SERIES (R)	82-86
JEEP® TJ	2001
JEEPSTER (R)	72-73
JEEP® CHEROKEE (F)	78-85
JEEP® CHEROKEE (R)	77-80
JEEP® COMANCHE XJ (R)	86-93
JEEP® WAGONEER (F)	74-84
JEEP® WAGONEER (R)	72-79
JEEP® GRAND WAGONEER (F)	85-91
THUNDERBIRD	55-56
VIPER (R)	93-00

R&P SUITABLE FOR DANA®

MG#	DANA® REF# REAR	DANA® REF# FRONT	TEETH	RATIO
▣ 706017-1X	706017-1X	706017-1X	43-14	3.07
▣ 706017-2X	706017-2X	706017-2X	43-13	3.31
D44-354	706017-3X	706017-3X	46-13	3.54
D44-354		707020-3X*	46-13	3.54
D44-354		707338-1X*	46-13	3.54
D44-354F~		707240-6X (1)	46-13	3.54
▣ 707381-3X(2)		707381-3X (2)	39-11	3.55
D44-373	706017-4X	706017-4X	41-11	3.73
▣ 707381-4X(2)	707381-4X(2)		41-11	3.73
D44-373F~			41-11	3.73
D44-392	706017-11X	706017-11X	47-12	3.92
D44-392		707020-5X*	47-12	3.92
D44-392		707338-2X*	47-12	3.92
D44-409	706017-5X	706017-5X	45-11	4.09
D44-409F~		707240-9X	45-11	4.09
D44-409F~		707283-9X**	45-11	4.09
▣ 707309-1X			41-10	4.10
D44-427	706017-10X	706017-10X	47-11	4.27
▣ 706017-21X		706017-21X	50-11	4.55
D44-456			41-9	4.56
D44-456F~			41-9	4.56
▣ D44-456GX***			41-9	4.56
▣ D44-488GX***			39-8	4.88
D44-489			44-9	4.89
D44-489F~			44-9	4.89
D44-513			41-8	5.13
D44-513F~			41-8	5.13
▣ D44-513GX***			41-8	5.13
D44-538	706017-8X	706017-8X	43-8	5.38
D44-538F~			43-8	5.38
D44-589	706017-9X		53-9	5.89

- ▶ DANA® / SPICER® Kit includes ring & pinion, gasket, pinion bearings, bolts, seal and shims, pinion nut and washer.
- ▶ MOTIVE GEAR® Part # is ring & pinion only.

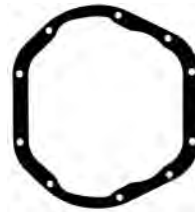

9-3/8" X 10-1/4"
10 HOLES
OVAL

SPECIFICATIONS:

- RG DIAMETER 8.5"
 - 10 3/8" X 24 RH THREADED BOLTS
 - PINION DIAMETER 1.376" 26 SPLINES
 - CASES: 3.73 & NUMERICALLY LOWER
3.92 & NUMERICALLY HIGHER
- 8620 Material - Heat Treated

NOTE: WHILE WE HAVE MADE EVERY EFFORT TO INCLUDE HELPFUL APPLICATION NOTES, WE RECOMMEND YOU SPECIFY BILL OF MATERIAL WHEN ORDERING.

- ~ REVERSE CUT PINION
- (1) REVERSE SPIRAL BEVEL FOR FORD FRONT
- (2) FITS LATE JEEP - SETS UP WITH CRUSH SLEEVE
- * FITS DODGE IFS FRONT. WHEN BUYING MOTIVE R&P, USE CORRECT BEARING KIT.
- ** FITS FORD IFS FRONT. WHEN BUYING MOTIVE R&P, USE CORRECT BEARING KIT.
- *** FITS JEEP RUBICON THICK GEAR

**SEE INSTALLATION KITS
& KIT COMPONENTS ON
NEXT PAGE**



DANA® 44 STYLE (CONT.)

DANA® 44 STYLE INSTALLATION KITS & KIT COMPONENTS

DESCRIPTION	INSTALLATION KIT NO.	BEARING KIT NO.	MASTER KIT NO.	SUPER KIT NO.
44 ICA STYLE CORVETTE® 8.5"		R44RICA R44RICAL	COMING SOON R44RICALMK	
44 BEFORE 1967 (FRONT & REAR)	D44IK	RA28R RA28RT*	RA28RMK RA28RMKT*	
44 1967 & LATER (FRONT & REAR)	D44IK	RA28LR RA28LRT*	RA28LRMK RA28LRMKT*	
44 JEEP® 1997-ON		RA28JLR RA28JLRT*	RA28JLRMK RA28JLRMKT*	
44 FORD® 1992-1996 IFS & BRONCO 1994 1994-ON RAM W/DISCONNECT		RA28FLR RA28FLRT*	RA28FLRMK RA28FLRMKT*	

*KIT CONTAINS TIMKEN® BEARINGS

DESCRIPTION	PINION SHIMS	CARRIER SHIMS	CRUSH SLEEVE	PINION SEAL	PINION NUT	RING GEAR BOLT	COVER GASKET
44 ICA STYLE CORVETTE® 1984-96	1100	1115	1107A	9316	1500	41221	
44 ICA STYLE CORVETTE® 1980-82	1104	1115	1114	5778V	1500	41221	5130
DANA® 44 STYLE 19 SPL	1113	1115	1114	5778	30185	41221	5114
DANA® 44 STYLE 30 SPL	1129R	1115	1114	5778	30185	41221	5114
DANA® 44 JEEP® 1994-ON	1134R	1115	43916	9316	30185	41221	107276

DANA® 50 STYLE

MODEL#	YEAR
EXCURSION	2000-ON
FORD® TRUCK F250 / F350 (F)	78-ON
FORD® 3/4 TON (F)	80-ON
FORD® 1 TON (F)	80-ON



9-3/8" X 10-1/4"
10 HOLES
OVAL

MOTIVE GEAR PERFORMANCE® R&P

MGP#	DANA® REF#	TEETH	RATIO
707239-2X*	707239-2X*	41-10	4.10
D50-430+		43-10	4.30
D50-456+		41-9	4.56
D50-489+		44-9	4.89
D50-513+		41-8	5.13
D50-538+		43-8	5.38

* Includes ring and pinion, gasket, pinion bearings, bolts, seal shims, pinion nut, washer, slinger, baffle and snap ring. MOTIVE GEAR® Part# is ring & pinion only.
+ Fits 4.10 & Down Case.

SPECIFICATIONS

- RG DIAMETER 8.5"
 - 10 3/8" X 24 RH THREADED BOLTS
 - PINION DIAMETER 1.376" 26 SPLINES
 - CASES: 4.10 & NUMERICALLY LOWER
- 8620 Material - Heat Treated

NOTE: WHILE WE HAVE MADE EVERY EFFORT TO INCLUDE HELPFUL APPLICATION NOTES, WE RECOMMEND YOU SPECIFY BILL OF MATERIAL WHEN ORDERING.

SEE INSTALLATION KITS
& KIT COMPONENTS ON
NEXT PAGE



DANA® 50 STYLE (CONT.)

DANA® 50 STYLE INSTALLATION KITS & KIT COMPONENTS

DESCRIPTION	INSTALLATION KIT NO.	BEARING KIT NO.	MASTER KIT NO.	SUPER KIT NO.
1980-1997 FORD® F250	D50IK	R50R R50RT*	R50RMK R50RMKT*	
1998-ON F250 & EXCURSION	D50IK	R50RL R50RLT*	R50RLMK R50RLMKT*	

*KIT CONTAINS TIMKEN® BEARINGS

DESCRIPTION	PINION SHIMS	CARRIER SHIMS	CRUSH SLEEVE	PINION SEAL	PINION NUT	RING GEAR BOLT	COVER GASKET
DANA® 50	1112	1117	1114 / 44896	5778 / 50531	30185	41221	107276

UNMATCHED
power • performance • durability

Motive Gear Performance®

Motive Gear Performance® drivetrain and differential product offerings surpass the competition in quality, durability and overall performance. Our extensive product line includes:

- ▶ Ring & Pinions
- ▶ Axles
- ▶ Spools, Cases, Housings, and Yokes
- ▶ Bearings
- ▶ Internal Kits

MGP Ring & Pinions

- ▶ Computerized Heat Treatment
- ▶ Gleason 5 Cut Technology
- ▶ Solid Shank Pinion Shaft
- ▶ Central Contact Pattern
- ▶ Indexed Tooth Spacing
- ▶ Cutting Edge Lapping
- ▶ CNC Start to Finish

DANA® 60 STYLE

R&P SUITABLE FOR DANA®				
MG#	DANA® REF# REAR	DANA® REF# FRONT	TEETH	RATIO
D60-354	706033-1X	706033-1X	46-13	3.54
■ 700020-1		700020-1~	46-13	3.54
■ 706033-15X		706033-15X	39-11	3.55
■ 708009-1*	708009-1*		39-11	3.55
■ 708125-6**	708125-6**		39-11	3.55
D60-373	706033-2X	706033-2X	41-11	3.73
■ 708125-4**	708125-4**		41-11	3.73
■ 708021-1			45-11	4.09
D60-410	706033-3X	706033-3X	41-10	4.10
D60-410F~		700020-2~	41-10	4.10
■ 708123-2^		708123-2^	41-10	4.10
■ 708009-2*	708009-2*		41-10	4.10
■ 708125-5**	708125-5**		41-10	4.10
■ 708123-3^		708123-3^	43-10	4.30
D60-456	706033-4X	706033-4X	41-9	4.56
D60-456XF•			41-9	4.56
■ 708123-4^		708123-4^	39-8	4.88
D60-488XF•			39-8	4.88
D60-513	706033-9X	706033-9X	41-8	5.13
D60-513XF•			41-8	5.13
D60-538			43-8	5.38
■ 708123-5^		708123-5^	43-8	5.38
D60-538XF•			43-8	5.38
■ 706033-6X	706033-6X	706033-6X	41-7	5.86

R&P SUITABLE FOR DANA® (cont)				
MG#	DANA® REF# REAR	DANA® REF# FRONT	TEETH	RATIO
706033-7X		706033-7X	37-6	6.17
706033-8X		706033-8X	43-6	7.17
~	REVERSE CUT - FRONT			
*	DODGE® ONLY - REAR			
**	FORD® ONLY - REAR			
^	FITS LATE 2000-ON - FORD® FRONT REVERSE REVERSE ROTATION THICK GEAR - FITS 4.10 & NUMERICALLY LOWER RATIO CASE			
DANA® /SPICER® kits include: R&P, bearings, shim, seal, gasket and ring bolts.				

MOTIVE GEAR PERFORMANCE® R&P		
MGP#	TEETH	RATIO
■ D897373	41-11	3.73
■ D897390	39-10	3.90
■ D897410	41-10	4.10
■ D897430	43-10	4.30
■ D897456	41-9	4.56

MOTIVE GEAR® Part# is ring & pinion only.

SPECIFICATIONS:

- RG DIAMETER 9.75"
 - 12 1/2" X 18 RH THREADED BOLTS
 - PINION DIAMETER 1.626" 29 SPLINES
 - CASES: 4.10 & NUMERICALLY LOWER 4.56 & NUMERICALLY HIGHER
- 8620 Material - Heat Treated

NOTE: WHILE WE HAVE MADE EVERY EFFORT TO INCLUDE HELPFUL APPLICATION NOTES, WE RECOMMEND YOU SPECIFY BILL OF MATERIAL WHEN ORDERING.

DANA® 60 STYLE INSTALLATION KITS & KIT COMPONENTS

DESCRIPTION	INSTALLATION KIT NO.	BEARING KIT NO.	MASTER KIT NO.	SUPER KIT NO.
1950-ON	D60IK	RA29R RA29RT*	RA29RMK RA29RMKT*	
2000-ON FRONT FORD®	D60IK	RA29RA RA29RAT*	RA29RAMK RA29RAMKT*	
1998-ON REAR	D60IK	RA29RL RA29RLT*	RA29RLMK RA29RLMKT*	

*KIT CONTAINS TIMKEN® BEARINGS

DESCRIPTION	PINION SHIMS	CARRIER SHIMS	CRUSH SLEEVE	PINION SEAL	PINION NUT	RING GEAR BOLT	COVER GASKET
DANA® 60	1110R	1106	1118	6808N / 9316	30271	40638	5116

DANA® 70 STYLE

MODEL#	YEAR
CHEVY® 1 TON - VARIOUS MODELS	74 & BEFORE
CHRYSLER® TRUCK (R)	61-83
DODGE® 1 TON - VARIOUS MODELS	74 & BEFORE
FORD® 1 TON - VARIOUS MODELS	74 & BEFORE
FORD® TRUCK (R)	61-83
GM® TRUCK (R)	73-90



9-3/8" X 10-1/4"
10 HOLES
OVAL

R&P SUITABLE FOR DANA®			
MG#	DANA® REF# REAR	TEETH	RATIO
D70-354	706998-1X(2)	46-13	3.54
D70-354	706999-1X(3)	46-13	3.54
■ 708015-1(4)(A)	708015-1(4)(A)	46-13	3.54
■ 708015-4(4)(5)(A)	708015-4(4)(5)(A)	46-13	3.54
D70-373	706998-2X(2)	41-11	3.73
D70-373	706999-2X(3)	41-11	3.73
■ 706997-1X(1)	706997-1X(1)	41-10	4.10
D70-410	706998-3X(2)	41-10	4.10
D70-410	706999-4X(3)	41-10	4.10
■ 708015-2(4)(A)	708015-2(4)(A)	41-10	4.10
■ 708015-5(4)(5)(A)	708015-5(4)(5)(A)	41-10	4.10
■ 707407-1X(4)(B)	707407-1X(4)(B)	41-10	4.10
■ 707482-1X(3)(C)	707482-1X(3)(C)	41-10	4.10
■ 708074-1(D)	708074-1(D)	41-10	4.10
■ 708126-1(E) (NLA)	708126-1(E)	41-10	4.10

R&P SUITABLE FOR DANA®			
MG#	DANA® REF# REAR	TEETH	RATIO
■ 708127-1(F)	708127-1(F)	41-10	4.10
■ 706997-2X(1)	706997-2X(1)	41-9	4.56
D70-456	706998-4X(2)	41-9	4.56
D70-456	706999-6X(3)	41-9	4.56
■ 707482-2X(3)(C)	707482-2X(3)(C)	41-9	4.56
■ 708074-2(D)	708074-2(D)	41-9	4.56
■ 708127-2(F)	708127-2(F)	41-9	4.56
D70-488	70698-5X(2)	39-8	4.88
D70-488	706999-8X(3)	39-8	4.88
D70-513	706999-9X(3)	41-8	5.13
D70-513E(1)	706997-4X(1)	41-8	5.13
D70-586	706999-10X(3)	41-7	5.86
■ 706999-12X(3)	706999-12X(3)	37-6	6.17
■ 706998-9X(2)		41-08	7.17
■ 706999-14X(3)	706999-14X(3)	41-08	7.17

- (1) MODEL 70 STYLE WITH .500" OFFSET OF PINION
- (2) MODEL 70U STYLE WITH .625" OFFSET
- (3) MODEL 70B & 70HD STYLE WITH .625" OFFSET WITHOUT DIFFERENTIAL SPACER
- (4) MODEL 70-2U STYLE WITH .625" OFFSET
- (5) SHOT PEENED FOR QUIETER OPERATION
- (A) 1991-2001 DODGE® REAR 3/4 & 1 TON
- (B) 1997-2000-5 FORD® REAR E350-W
- (C) 1997.5-2000.5 FORD® REAR E350-W HD CHASSIS
- (D) 2000-2002 FORD® REAR E350-E450
- (E) 2001 FORD® REAR E350 DUAL REAR WHEEL WITH ABS
- (F) 2001 FORD® REAR E450 SUPER DUTY DUAL REAR WHEEL ABS

DANA SPICER Kit includes:

Ring & pinion, gasket, pinion bearings, bolts, seal and shims, pinion nut and washer. MOTIVE GEAR® Part # is ring & pinion only.

SPECIFICATIONS:

- RG DIAMETER 10.50"
 - 12 1/2" X 18 RH THREADED BOLTS
 - PINION DIAMETER 1.750" 29 SPLINES
 - CASES: 4.10 & NUMERICALLY LOWER 4.56 & NUMERICALLY HIGHER
- 8620 Material - Heat Treated

NOTE: WHILE WE HAVE MADE EVERY EFFORT TO INCLUDE HELPFUL APPLICATION NOTES, WE RECOMMEND YOU SPECIFY BILL OF MATERIAL WHEN ORDERING.

DANA® 70 STYLE INSTALLATION KITS & KIT COMPONENTS

DESCRIPTION	INSTALLATION KIT NO.	BEARING KIT NO.	MASTER KIT NO.	SUPER KIT NO.
1961-1983	D70IK	R70R R70RT*	R70RMK R70RMKT*	

*KIT CONTAINS TIMKEN® BEARINGS

DESCRIPTION	PINION SHIMS	CARRIER SHIMS	CRUSH SLEEVE	PINION SEAL	PINION NUT	RING GEAR BOLT	COVER GASKET
DANA® 70 STYLE	1111	1106	1118	6808N / 9316	30271	40638	5117

DANA 70 INSTALLATION KITS & KIT COMPONENTS CONT.



DANA® 70 STYLE (CONT.)

DANA® 70 U STYLE INSTALLATION KITS & KIT COMPONENTS

DESCRIPTION	INSTALLATION KIT NO.	BEARING KIT NO.	MASTER KIT NO.	SUPER KIT NO.
10.5"	D70IK	R70UR R70URT*	R70URMK R70URMKT*	

*KIT CONTAINS TIMKEN® BEARINGS

DESCRIPTION	PINION SHIMS	CARRIER SHIMS	CRUSH SLEEVE	PINION SEAL	PINION NUT	RING GEAR BOLT	COVER GASKET
DANA® 70U STYLE	1110R	1106	1118	6808N / 9316	30271	40638	5117

DANA® 70 HD STYLE INSTALLATION KITS & KIT COMPONENTS

DESCRIPTION	INSTALLATION KIT NO.	BEARING KIT NO.	MASTER KIT NO.	SUPER KIT NO.
1972-ON	D70IKH	R70HR R70HRT*	R70HRMK R70HRMKT*	

*KIT CONTAINS TIMKEN® BEARINGS

DESCRIPTION	PINION SHIMS	CARRIER SHIMS	CRUSH SLEEVE	PINION SEAL	PINION NUT	RING GEAR BOLT	COVER GASKET
DANA® 70 HD STYLE	1111	1106	1118	6808N / 9316	30271	40638	5117



QUALITY

Motive Gear supplies quality axle shafts for light, medium, off road, and performance applications. Most popular domestic and import sizes are available. Your customers will experience:

- Easy installation
- Unmatched durability
- Comprehensive warranty
- High quality

MOTIVE GEAR ALSO SUPPLIES:
ring & pinions · cases · internal kits · driveline · new & rebuilt units · manual transmission & transfer case components · complete rebuild kits · bearing kits for ALL drivetrain applications

DANA® 80 STYLE

MODEL#	YEAR
CHRYSLER® 3/4 TON	94-ON
CHRYSLER® 1 TON	94-ON
CHEVROLET® C3500 1 TON	88-99
DODGE® D/W350	94-2001
FORD® 1 TON	88-ON
FORD® F350, F450	88-2002
GM® 1 TON	91-99



13-7/16"
10 HOLES
IRREGULAR

R&P SUITABLE FOR DANA®				
MG#	DANA® REF#	TEETH	RATIO	
707060-7X	707060-7X	43-13	3.31	
708120-5	708120-5	46-13	3.54	
707060-3X	707060-3X	41-11	3.73	
708120-6	708120-6	41-10	4.10	
708120-7	708120-7	43-10	4.30	
D80-463	707060-1X	37-08	4.63	
D80-488		39-08	4.88	
D80-513	707060-13X	41-08	5.13	
708120-11	708120-11	43-08	5.38	

DANA® Kit includes ring & pinion, gasket, pinion bearings, bolts, seal and shims, pinion nut and washer. MOTIVE GEAR® part # is ring & pinion only.

SPECIFICATIONS:

- RG DIAMETER 11.25"
 - 12 1/2" X 20 RH THREADED BOLTS
 - PINION DIAMETER 2" 37 SPLINES
 - CASES: 3.73 & NUMERICALLY LOWER 4.10 & NUMERICALLY HIGHER
- 8620 Material - Heat Treated

▶ Early DANA® 80 (pre-1998) 707060 DANA®/ SPICER® kits include a 4.125 diameter outer pinion bearing.

▶ Late DANA® 80 (1998 & Newer) 708120 DANA®/ SPICER® include a 4.375 diameter outer pinion bearing.

Please note this difference when ordering!

NOTE: WHILE WE HAVE MADE EVERY EFFORT TO INCLUDE HELPFUL APPLICATION NOTES, WE RECOMMEND YOU SPECIFY BILL OF MATERIAL WHEN ORDERING.

DANA® 80 STYLE INSTALLATION KITS & KIT COMPONENTS

DESCRIPTION	INSTALLATION KIT NO.	BEARING KIT NO.	MASTER KIT NO.	SUPER KIT NO.
1988-1998	D80IK	R80R R80RT*	R80RMK R80RMKT*	
1998-ON	D80IK	R80RA R80RAT*	R80RAMK R80RAMKT*	

*KIT CONTAINS TIMKEN® BEARINGS

DESCRIPTION	PINION SHIMS	CARRIER SHIMS	CRUSH SLEEVE	PINION SEAL	PINION NUT	RING GEAR BOLT	COVER GASKET
DANA® 80	1111	1106	1132	4525V	37082	42433	107276

FORD® 7.5" STYLE

MODEL#	YEAR
AEROSTAR	90-97
BOBCAT	76-81
BRONCO II	83-92
CAPRI (EXCEPT 86' W/ V8)	79-86
COUGAR	80-97
EXPLORER (R)	91-97
EXPLORER SPORT	2001-ON
TRAC (R)	

MODEL#	YEAR
FAIRMONT	78-83
FORD® FULL SIZE	79-81
GRANADA	81-82
MERCURY® FULL SIZE	80-81
MONARCH CAR (R)	79-80
MUSTANG 4 & 6 CYL.	80-ON
RANGER W/O 4.0L	83-ON
THUNDERBIRD	80-97
ZEPHYR	79-83



10-3/4" X 9-9/16"
10 HOLES
OVAL

SPECIFICATIONS:

- RG DIAMETER 7.5"
 - 10 7/16" X 20 RH THREADED BOLTS
 - PINION DIAMETER 1.626" 28 SPLINES
 - NO CASE BREAKS
- 8620 Material - Heat Treated

MOTIVE GEAR® R&P			
MG#	MOTORSPORT® REFERENCE#	TEETH	RATIO
F7.5-308	M4209L308	37-12	3.08
F7.5-345	M4209L345	38-11	3.45
F7.5-373*	M4209L373	41-11	3.73
F7.5-410*	M4209L410	41-10	4.10
F7.5-456*	SEE PERFORMANCE SECTION		

* REQUIRES CROSS SHAFT F7.5CS
(WILL NOT FIT IN AUBURN® CARRIER)

MOTIVE GEAR PERFORMANCE® R&P		
MGP#	TEETH	RATIO
■ F875373	41-11	3.73
■ F875410	41-10	4.10
F875456*	41-9	4.56

* REQUIRES CROSS SHAFT F7.5CS

FORD® 7.5" STYLE INSTALLATION KITS & KIT COMPONENTS

DESCRIPTION	INSTALLATION KIT NO.	BEARING KIT NO.	MASTER KIT NO.	SUPER KIT NO.
1979-ON	F7.5IK	R7.5FR R7.5FRT*	R7.5FRMK R7.5FRMKT*	R7.5FRSK R7.5FRSKT*

*KIT CONTAINS TIMKEN® BEARINGS

DESCRIPTION	PINION SHIMS	CARRIER SHIMS	CRUSH SLEEVE	PINION SEAL	PINION NUT	RING GEAR BOLT	COVER GASKET
FORD® 7.5	1100	1105	B7A4662A	3604	379570S	D5AZ4216A	5119

FORD® 8" STYLE

MODEL#	YEAR
AUSTRALIAN XT, GT	1968
BOBCAT	76-81
COMET	64-72
COUGAR	67-68
FAIRLANE	60-72
FAIRMONT	75-79
FALCON	62-70

MODEL#	YEAR
GRANADA	75-79
MAVERICK	71-78
MONARCH	74-80
MUSTANG	64-78
PINTO	71-80
TORINO	71-74
ZEPHYR	78-79



11"
10 HOLES
OVAL

MOTIVE GEAR PERFORMANCE® R&P		
MGP#	TEETH	RATIO
F880300	39-13	3.00
F880325	39-12	3.25
F880340	34-10	3.40
F880355	39-11	3.55
F880380	38-10	3.80
F880411	37-9	4.11

SPECIFICATIONS:

- RG DIAMETER 8"
 - 10 7/16" X 20 RH THREADED BOLTS
 - PINION DIAMETER 1.188" 25 SPLINES
 - NO CASE BREAKS
- 8620 Material - Heat Treated

FORD® 8" STYLE INSTALLATION KITS & KIT COMPONENTS

DESCRIPTION	INSTALLATION KIT NO.	BEARING KIT NO.	MASTER KIT NO.	SUPER KIT NO.
1964-80	F8IK	RA310R RA310RT*	RA310RMK RA310RMKT*	RA310RSK RA310RSKT*
1964-1980 W/AUBURN®	F8IK	RA310RA RA310RAT*	RA310RAMK RA310RAMKT*	RA310RASK RA310RASKT*

*KIT CONTAINS TIMKEN® BEARINGS

DESCRIPTION	PINION SHIMS	CARRIER SHIMS	CRUSH SLEEVE	PINION SEAL	PINION NUT	RING GEAR BOLT	COVER GASKET
FORD® 8	2102	N/A	3507575	8181NA	379570S	D8OZ4216B	5123 / 5128



FORD® 8.8" STYLE

MODEL#	YEAR	MODEL#	YEAR
AEROSTAR W/4.0L	90-97	FORD® 1/2 TON (R)	83-ON
BRONCO	83-96	FORD® 3/4 TON (R)	83-89
CAPRI V8	86	FULL SIZE CAR	80-ON
COUGAR	80-97	MUSTANG V8	86-ON
E150-E250	83-99	RANGER W/ 4.0L	83-ON
EXPEDITION	97-ON	THUNDERBIRD	87-97
EXPLORER	91-ON		
F100	81-90		
F150-250	81-2002		
F150 (F)	97-2002		
FORD® 1/2 TON (F)	97-ON		

***Starting 1997, production model F150 comes with factory Ford® 8.8 IFS style reverse cut gears.**



10-9/16" X 10-13/16"
10 HOLES
OVAL

SPECIFICATIONS:

- RG DIAMETER 8.80"
 - 10 7/16" X 20 RH THREADED BOLTS
 - PINION DIAMETER 1.626" 30 SPLINES
 - NO CASE BREAKS
- 8620 Material - Heat Treated

MOTIVE GEAR PERFORMANCE® R&P REAR			
MGP#	OEM REF#	TEETH	RATIO
F888308	M4209F308	40-13	3.08
F888327	M4209F327	36-11	3.27
F888331	-	43-13	3.31
F888355	M4209G355	39-11	3.55
F888373	M4209F373	41-11	3.73
F888390	-	43-11	3.90
F888410	M4209G410	41-10	4.10
F888430	M4209G430	43-10	4.30
F888456	M4209G456	41-9	4.56
F888488	-	39-8	4.88
F888514	-	36-7	5.14
F888571	-	40-7	5.71
F888614	-	43-7	6.14

MOTIVE GEAR® R&P			
MG#	OEM REF#	TEETH	RATIO
F8.8-308	E7TZ4209A	40-13	3.08
F8.8-327	E7TZ4209B	36-11	3.27
F8.8-355	E3TZ4209J	39-11	3.55
F8.8-373	E4TZ4209A	41-11	3.73
F8.8-410	E9TZ4209B	41-10	4.10
F8.8-456		41-9	4.56
F8.8-488		39-8	4.88

MOTIVE GEAR® R&P - FRONT			
MG#	ALT REF#	TEETH	RATIO
F888331IFS	(F8.8-331IFS)	43-13	3.31
F888355IFS	(F8.8-355IFS)	39-11	3.55
F888373IFS	(F8.8-373IFS)	41-11	3.73
F888410IFS	(F8.8-410IFS)	41-10	4.10
F888456IFS	(F8.8-456IFS)	41-9	4.56
F888488IFS	(F8.8-488IFS)	39-8	4.88

FORD® 8.8" STYLE INSTALLATION KITS & KIT COMPONENTS

DESCRIPTION	INSTALLATION KIT NO.	BEARING KIT NO.	MASTER KIT NO.	SUPER KIT NO.
1981-ON	F8.8IK	R8.8R R8.8RT*	R8.8RMK R8.8RMKT*	R8.8RSKC (CAR) R8.8RSKT (TRK) R8.8RSKCT* R8.8RSKTT*
8.8 IFS STYLE 1997-ON	F8.8IKF	R8.8RIFS R8.8RIFST*	R8.8RIFSMK R8.8RIFSMKT*	

*KIT CONTAINS TIMKEN® BEARINGS

DESCRIPTION	PINION SHIMS	CARRIER SHIMS	CRUSH SLEEVE	PINION SEAL	PINION NUT	RING GEAR BOLT	COVER GASKET
FORD® 8.8	1100	1101	B7A4662A	3604	379570S	D5AZ4216A	5122

FORD® 9" STREET GEARS STYLE 1957 & UP

MODEL#	YEAR	MODEL#	YEAR	MODEL#	YEAR	MODEL#	YEAR
AUSTRALIAN FALCON	69-74	E100/150	86-87	FORD® 1/2 TON (28 SPL)	57-5/70	MONTEGO (31 SPL)	5/70-76
GT, XW, XY, XA, XB		E200	68-74	FORD® 1/2 TON (31 SPL)	5/70-86	MONARCH	75-80
AUSTRALIAN FAIRLANE	69-74	F100/150	64-86	FORD® 3/4 TON (28 SPL)	69-5/70	MUSTANG (28 SPL)	65-5/70
ZC, ZD		FAIRLANE (28 SPL)	57-5/70	FORD® 3/4 TON (31 SPL)	5/70-74	MUSTANG (31 SPL)	5/70-73
BRONCO (28 SPL)	67-5/70	FAIRLANE (31 SPL)	5/70-71	GRANADA	75-80	THUNDERBIRD (28 SPL)	57-5/70
BRONCO (31 SPL)	5/70-86	FORD® FULL SIZE		LTD II	71-79	THUNDERBIRD (31 SPL)	5/70-79
COMET/CYCLONE	65-67	(28 SPL)	57-5/70	MERCURY® (28 SPL)	57-5/70	VERSAILLES	77-80
COUGAR (28 SPL)	67-5/70	FORD® FULL SIZE		MERCURY® (31 SPL)	5/70-79		
COUGAR 31 SPL)	5/70-79	(31 SPL)	5/70-79	MONTEGO (28 SPL)	5/70-76		

MOTIVE GEAR® R&P			
MG#	OEM REF#	TEETH	RATIO
F9-300	C0AZ4209A	39-13	3.00
F9-325	B8AZ4209C	39-12	3.25
F9-350	C9OZ4209A	35-10	3.50
F9-370		37-10	3.70
F9-389	B7AZ4209E	35-9	3.89
F9-411	B7AZ4209K	37-9	4.11
F9-456		41-9	4.56
F9-486		34-7	4.86



11-3/4"
10 HOLES
OVAL

SPECIFICATIONS:

- 10 BOLT 3RD MEMBER
 - ALUM. OR STEEL HOUSING
 - RG DIAMETER 9"
 - 10 7/16" X 20 RH THREADED BOLTS
 - PINION DIAMETER 1.313" 28 SPLINES
 - NO CASE BREAKS
- 8620 Material - Heat Treated

FORD® 9" PERFORMANCE STYLE 1957 & UP

MOTIVE GEAR PERFORMANCE® R&P		
MGP#	TEETH	RATIO
F890300	39-13	3.00
F890325	39-12	3.25
F890350	35-10	3.50
F890364	33-9	3.64
F890370	37-10	3.70
F890375	45-12	3.75
F890389	35-9	3.89
F890411	37-9	4.11
F890430	43-10	4.30
F890457	32-7	4.57
F890471	33-7	4.71
F890486	34-7	4.86
F890500	35-7	5.00
F890514	36-7	5.14
F890529	37-7	5.29
F890543	38-7	5.43
F890567	34-4	5.67
F890583	35-6	5.83

MOTIVE GEAR PERFORMANCE® R&P		
MGP#	TEETH	RATIO
F890600	36-6	6.00
F890620	31-5	6.20
F890633	38-6	6.33
F890650	39-6	6.50



11-3/4"
10 HOLES
OVAL

SPECIFICATIONS:

- 10 BOLT 3RD MEMBER
 - ALUM OR STEEL HOUSING
 - RG DIAMETER 9"
 - 10 7/16" X 20 RH THREADED BOLTS
 - PINION DIAMETER 1.313" 28 SPLINES
 - NO CASE BREAKS
- 8620 Material - Heat Treated

FORD® 9" STYLE PERFORMANCE "AX" SERIES LIGHT WEIGHT RACING APP.'S

FOR USE IN:

NASCAR®	IMCA®
NEXTEL CUP®	UMP®
BUSCH GRAND NATIONAL®	IHRA®
CRAFTSMAN TRUCK®	NHRA®
ARCA®	



11-3/4"
10 HOLES
OVAL

SPECIFICATIONS:

- 10 BOLT 3RD MEMBER
- ALUM OR STEEL HOUSING
- RG DIAMETER 9"
- 10 7/16" X 20 RH THREADED BOLTS
- PINION DIAMETER 1.313" 28 SPLINES
- NO CASE BREAKS
- 8620 Material - Heat Treated

MOTIVE GEAR PERFORMANCE® "AX" SERIES R&P

MGP#	TEETH	RATIO
F890422AX	38-9	4.22
F890430AX	43-10	4.30
F890457AX	32-7	4.57
F890471AX	33-7	4.71
F890478AX	43-9	4.78
F890486AX	34-7	4.86
F890500AX	35-7	5.00
F890514AX	36-7	5.14
F890525AX	42-8	5.25
F890529AX	37-7	5.29
F890537AX	43-8	5.37
F890543AX	38-7	5.43
F890550AX	44-8	5.50
F890557AX	39-7	5.57
F890567AX	34-4	5.67

MOTIVE GEAR PERFORMANCE® "AX" SERIES R&P (cont)

MGP#	TEETH	RATIO
F890583AX	35-6	5.83
F890600AX	36-6	6.00
F890614AX	43-7	6.14
F890620AX	31-5	6.20
F890633AX	38-6	6.33
F890650AX	39-6	6.50
F890666AX	40-6	6.66
F890683AX	41-6	6.83
F890700AX	42-6	7.00
F890716AX	43-6	7.16
F890733AX	44-6	7.33

WE RECOMMEND THE USE OF A DAYTONA PINION SUPPORT & SOLID PINION SPACER IN ALL RACING APPLICATIONS.

FORD® 9" STYLE PERFORMANCE "AX" SERIES INSTALLATION KITS & KIT COMPONENTS

DESCRIPTION	INSTALLATION KIT NO.	BEARING KIT NO.	MASTER KIT NO.	SUPER KIT NO.
1957-1986 2.891 W/ LM102910 & LM102949 28 SPL. LATE 2.891 W/ LM501310 & LM501349	F9IK	R9R R9RT*	R9RMK R9RMKT*	
FORD® 9" 2.891 W/ LM102910 & LM102949 LG REAR PINION BEARINGS	F9IKN	R9R28 R9R28T*	R9R28MK R9R28MKT*	
FORD® 9" 3.062 W/ LM603011 & LM603049 STD REAR PINION BEARINGS	F9IKN	R9RN*	R9RNMK*	
FORD® 9" 3.062 W/ LM603011 & LM603049 LG REAR PINION BEARINGS	F9IKN	R9R306S*	R9R306SMK*	
FORD® 9" 3.062 W/ LM603011 & LM603049 LG REAR PINION BEARINGS	F9IKN	R9R306*	R9R306MK*	
FORD® 9" 3.25 BORE W/ LM104910 & LM104949 STD REAR PINION BEARINGS	F9IKN	R9R325S	R9R325SMK*	
FORD® 9" 3.25 BORE W/ LM104910 & LM104949 LG REAR PINION BEARING	F9IKN	R9R325*	R9R325MK*	

*KIT CONTAINS TIMKEN® BEARINGS

DESCRIPTION	PINION SHIMS	CARRIER SHIMS	CRUSH SLEEVE	PINION SEAL	PINION NUT	RING GEAR BOLT	COVER GASKET
FORD® 9 TL	WAA4663	N/A	*B7A4662A	3604 / 7044NA	379570S	D8OZ4216A	D5AZ4035A
FORD® 9 OPEN	WAA4663	N/A	*B7A4662A	3604 / 7044NA	379570S	D8OZ4216B	D5AZ4035A

*FOR SOLID SPACER w/SHIMS, USE PART NUMBER SS9.

FORD® 9" STYLE PRO GEARS

MOTIVE GEAR PERFORMANCE® R&P		
MGP#	TEETH	RATIO
F990389BP	35-9	3.89
F990411BP	37-9	4.11
F990429SP	30-7	4.29
F990429BP	30-7	4.29
F990457SP	32-7	4.57
F990457BP	32-7	4.57
F990486SP	34-7	4.86
F990486BP	34-7	4.86
F990514SP	36-7	5.14
F990529SP	37-7	5.29
F990543SP	38-8	5.42
F990567SP	34-6	5.67
F990583SP	35-6	5.83
F990600SP	36-6	6.00
F990620SP	31-5	6.20
F990650SP	39-6	6.50

No Installation Kits currently available.

FOR USE IN:
NHRA®
IHRA®



11-3/4"
10 HOLES
OVAL

SPECIFICATIONS:

- 10 BOLT 3RD MEMBER
 - ALUM. OR STEEL HOUSING
 - RG DIAMETER 9"
 - 10 7/16" X 20 RH THREADED BOLTS
 - PINION DIAMETER 1.313" 28 SPLINES SP
 - PINION DIAMETER 1.500" 35 SPLINES BP
 - NO CASE BREAKS
- 9310 Material - Heat Treated

SP = SMALL PINION - BP = BIG PINION

Motive Gear® is proud to sponsor Warren Johnson



NHRA® Pro Stock

FORD® 9.75" STYLE

MODEL#	YEAR
EXPEDITION	97-ON
E150	97-ON
E250	97-ON
E350	97-ON
F150	97-ON
FORD® 1/2 TON	97-ON
FORD® 3/4 TON	97-ON
NAVIGATOR	97-ON



12 HOLES
IRREGULAR

MOTIVE GEAR® R&P			
MG#	FORD® PART REF#	TEETH	RATIO
■ F9.75-355		39-11	3.55
■ F9.75-373		41-11	3.73
F9.75-410	-	41-10	4.10
F9.75-430		43-10	4.30
F9.75-456	-	41-9	4.56
F9.75-489		39-8	4.89

SPECIFICATIONS:

- RG DIAMETER 9.75"
- 12-12MM X 26 RH THREADED BOLTS
- PINION DIAMETER 1.970 31 SPLINES
- NO CASE BREAKS

8620 Material - Heat Treated

FORD® 9.75" STYLE INSTALLATION KITS & KIT COMPONENTS

DESCRIPTION	INSTALLATION KIT NO.	BEARING KIT NO.	MASTER KIT NO.	SUPER KIT NO.
1997-1999-1/2	F9.75IK	R9.75FR R9.75FRT*	R9.75FRMK R9.75FRMKT*	
1999-1/2-ON	F9.75IKL	R9.75FRL R9.75FRLT*	R9.75FRLMK R9.75FRLMKT*	

*KIT CONTAINS TIMKEN® BEARINGS

DESCRIPTION	PINION SHIMS	CARRIER SHIMS	CRUSH SLEEVE	PINION SEAL	PINION NUT	RING GEAR BOLT	COVER GASKET
TO 1999	1136R	1135R	B7A4662A	3604	44189	F75Z4216AA	107276
1999-ON	1136R	1135R	B7A4662A	4278	44189	F75Z4216AA	107276

FORD® 10.25" STYLE (EARLY) 1983 - 1992

MODEL#	YEAR
F350	83-92
F450	83-92



12-1/8" X 13-5/16"
14 HOLES
IRREGULAR

MOTIVE GEAR® R&P		
MG#	FORD®#	RATIO
F10.25-308*	E5TZ4209A	3.08
F10.25-355*	E5TZ4209B	3.55
F10.25-373*	E5TZ4209C	3.73
F10.25-410*	E5TZ4209D	4.10
F10.25-456*	-----	4.56

*You must change yoke if '93-Later Model - Yoke #E5TZ4851 (1330 Series) or E7TZ4851A (1350 Series). 1993 & later can use Motive Gear® F10.25L late ring & pinion series with no yoke change.

SPECIFICATIONS:

- RG DIAMETER 10.25"
 - 12 1/2" X 20 RH THREADED BOLTS
 - PINION DIAMETER 1.940" 31 SPLINEES: NO CASE BREAKS
- 8620 Material - Heat Treated

FORD® 10.25 STYLE (LATE) 1993 - 1999

MODEL#	YEAR
F350	94-ON
F450	94-ON



12-1/8" X 13-5/16"
14 HOLES
IRREGULAR

MOTIVE GEAR® R&P			
MG#	FORD®#	TEETH	RATIO
F10.25-355L		39-11	3.55
F10.25-373L	F81Z4209AA	41-11	3.73
F10.25-410L	F81Z4209AB	41-10	4.10
F10.25-456L		41-9	4.56
F10.25-489L		44-9	4.89
F10.25-513L		41-8	5.13
■ F10.25-538L		43-8	5.38

SPECIFICATIONS:

- RG DIAMETER 10.25"
 - 12-1/2 X 20 RH THREADED BOLTS
 - PINION DIAMETER 1.940" 31 SPLINE
 - CASES: NO CASE BREAKS
- 8620 Material - Heat Treated

FORD® 10.25" STYLE INSTALLATION KITS & KIT COMPONENTS

DESCRIPTION	INSTALLATION KIT NO.	BEARING KIT NO.	MASTER KIT NO.	SUPER KIT NO.
1985 - 1999	F10.25IK	R10.25R R10.5FRT*	R10.5FRMK R10.5FRMKT*	

*KIT CONTAINS TIMKEN® BEARINGS

DESCRIPTION	PINION SHIMS	CARRIER SHIMS	CRUSH SLEEVE	PINION SEAL	PINION NUT	RING GEAR BOLT	COVER GASKET
FORD® 10.25	1102	F10.25SSK	B7A4662A	4278	44189	E5TZ4216A	5125

FORD® 10.5" STYLE - 1999 & LATER

MODEL#	YEAR
EXCURSION	2000-ON
FORD® F350-450	99-2002
FORD® 3/4 TON	99-ON
FORD® 1 TON	99-ON

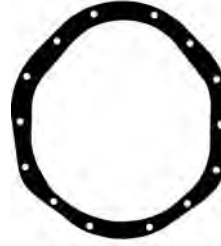

12-1/8" X 13-5/16"
14 HOLES
IRREGULAR

MOTIVE GEAR® R&P			
MG#	FORD® REF#	TEETH	RATIO
F10.5-355PK		39-11	3.55
F10.5-373PK		41-11	3.73
F10.5-410PK		41-10	4.10
F10.5-456PK		41-9	4.56
F10.5-489PK		41-8	4.89
F10.5-513PK		41-8	5.13

PK - These Kits include Ford® 10.25" Late Ring & Pinion with matching 10.25" inner & outer pinion bearings. **Do Not Substitute.** Use Ford® 10.25" Installation Kits.

SPECIFICATIONS:

- RG DIAMETER 10.5"
 - 12-1/2 X 20 RH THREADED BOLTS
 - PINION DIAMETER 1.940" 31 SPLINE
 - CASES: NO CASE BREAKS
- 8620 Material - Heat Treated

FORD® 10.5" STYLE 1999 & LATER INSTALLATION KITS & KIT COMPONENTS

DESCRIPTION	INSTALLATION KIT NO.	BEARING KIT NO.	MASTER KIT NO.	SUPER KIT NO.
FORD® 10.5"	F10.5IK	R10.5FR R10.5FRT*	R10.5FRMK R10.5FRMKT*	

*KIT CONTAINS TIMKEN® BEARINGS

DESCRIPTION	PINION SHIMS	CARRIER SHIMS	CRUSH SLEEVE	PINION SEAL	PINION NUT	RING GEAR BOLT	COVER GASKET
FORD® 10.5	1102	F10.25SSK	B7A4662A	4278	44189	E5TZ4216A	107276

GM® 7.2" STYLE

MODEL#	YEAR
BLAZER	83-ON
BRAVADA	2002-ON
ENVOY	2002-ON

MODEL#	YEAR
OLDS®	91-2002
S10, S15	83-ON
TRAILBLAZER	2002-ON

MOTIVE GEAR PERFORMANCE® R&P			
MGP#	OEM#	TEETH	RATIO
GM7.2-410IFS	14071743	41-10	4.10
GM7.2-456IFS	-	41-9	4.56

SPECIFICATIONS:

- RG DIAMETER 7.25"
 - 10 3/8 X 18 RH THREADED BOLTS
 - PINION DIAMETER 1.315" 27 SPLINES
 - CASES: 3.08 & Numerically Lower - 3.42 & Numerically Higher
- 8620 Material - Heat Treated

SEE INSTALLATION KITS
& KIT COMPONENTS ON
NEXT PAGE



GM® 7.2" STYLE (CONT.)

GM® 7.2" STYLE INSTALLATION KITS & KIT COMPONENTS

DESCRIPTION	INSTALLATION KIT NO.	BEARING KIT NO.	MASTER KIT NO.	SUPER KIT NO.
IFS 1983-ON S10 ONLY NO ASTRO	GM7.2IKF	R7.2RIFS R7.2RIFST*	R7.2RIFSMK R7.2RIFSMKT*	

*KIT CONTAINS TIMKEN® BEARINGS.

DESCRIPTION	PINION SHIMS	CARRIER SHIMS	CRUSH SLEEVE	PINION SEAL	PINION NUT	RING GEAR BOLT	COVER GASKET
GM® 7.2 IFS	1104	N/A	3974898	8610	1260823	14056135	N/A

GM® 7.5" & 7.625" STYLE

MODEL#	YEAR	MODEL#	YEAR
ASTRO	85-ON	GRAND PRIX	78-87
BUICK® FULL SIZE	75-86	ISUZU® RODEO	89-93
BUICK® MID SIZE	73-87	MONTE CARLO	81-88
CAMARO	82-ON	OLDS® FULL SIZE	77-85
CENTURY/PHOENIX		OLDS® BRAVADA	91-ON
VENTURA	78-81	OMEGA	75-79
CHEVY® FULL SIZE	75-96	PONTIAC® FULL SIZE	77-86
CHEVY® MID-SIZE	76-80	REGAL	78-83
CUTLASS	78-88	SKYLARK	76-79
FIRDBIRD	82-ON	S10, S15	82-ON



8-5/16" X 10-9/16"
10 HOLES
OVAL

SPECIFICATIONS:

- RG DIAMETER 7.50"
 - 10 3/8" X 18 LH THREADED BOLTS
 - PINION DIAMETER 1.438" 27 SPLINES
 - CASES: 3.08 & NUMERICALLY LOWER 3.23 & NUMERICALLY HIGHER
- 8620 Material - Heat Treated

MOTIVE GEAR PERFORMANCE® R&P

MGP#	OEM REF#	TEETH	RATIO
G875273	26043281	41-15	2.73
G875308	26026781	40-13	3.08
G875323	26046641	42-13	3.23
G875342	26026782	41-12	3.42
G875342X*		41-12	3.42
G875373	26036813	41-11	3.73
G875373X*		41-11	3.73
G875390		43-11	3.90
G875410	26014585	41-10	4.10
G875410X*		41-10	4.10
G875456	26014587	41-9	4.56

*FITS 3.08 & NUMERICALLY LOWER CASE

MOTIVE GEAR® R&P

MG#	OEM REF#	TEETH	RATIO
GM7.5-308	26026781	40-13	3.08
GM7.5-323	26046641	42-13	3.23
GM7.5-342	26026782	41-12	3.42
GM7.5-373	26036813	41-11	3.73
GM7.5-410	26014585	41-10	4.10
GM7.5-456	26014587	41-9	4.56

SEE INSTALLATION KITS &
KIT COMPONENTS ON NEXT PAGE



GM® 7.5" & 7.625" STYLE (CONT.)

GM® 7.5" & 7.625" STYLE INSTALLATION KITS & KIT COMPONENTS

DESCRIPTION	INSTALLATION KIT NO.	BEARING KIT NO.	MASTER KIT NO.	SUPER KIT NO.
1977 -1981 10 BOLT	GM 7.5IK	R7.5GRB R7.5GRBT*	R7.5GRBMK R7.5GRBMKT*	R7.5GRBSK R7.5GRBSKT*
1982 -1998 10 BOLT	GM 7.5IK	R7.5GR R7.5GRT*	R7.5GRMK R7.5GRMKT*	R7.5GRSK R7.5GRSKT*
1999-ON 10 BOLT	GM 7.5IK	R7.5GRL R7.5GRLT*	R7.5GRLMK R7.5GRLMKT*	R7.5GRSK R7.5GRSKT*

*KIT CONTAINS TIMKEN® BEARINGS

DESCRIPTION	PINION SHIMS	CARRIER SHIMS	CRUSH SLEEVE	PINION SEAL	PINION NUT	RING GEAR BOLT	COVER GASKET
GM® 7.5 / 7.625	1104	1105	9785792	8610	1260823	14066913	5110

GM 7.60" IFS FRONT STYLE

MODEL#	YEAR
MID-SIZE TRUCKS 4WD	2004-ON

MOTIVE GEAR® R&P - FRONT			
MG#	OEM REF#	TEETH	RATIO
GM7.6-342IFS			3.42
GM7.6-373IFS			3.73
GM7.6-410IFS			4.10



10 HOLES
OVAL
IRREGULAR

SPECIFICATIONS:

- 10 BOLT COVER
- RG DIAMETER 7.60"
- 10- 7/16" X 20 RH THREADED BOLTS
- PINION DIAMETER 1.438" 28 SPLINES
- CASES: NO CASE BREAK

GM® 7.60" IFS FRONT STYLE INSTALLATION KITS & KIT COMPONENTS

DESCRIPTION	INSTALLATION KIT NO.	BEARING KIT NO.	MASTER KIT NO.	SUPER KIT NO.
2004-ON 4WD MID-SIZE TRUCKS FRONT	GM 7.6 IFSIK	R7.6RIFS R7.6RIFST*	R7.6RIFSMK R7.6RIFSMKT*	N/A N/A

*KIT CONTAINS TIMKEN® BEARINGS

DESCRIPTION	PINION SHIMS	CARRIER SHIMS	CRUSH SLEEVE	PINION SEAL	PINION NUT	RING GEAR BOLT	COVER GASKET
GM® 7.6 IFS	1104	1105	9785792	12479267	9783762	14066913	107276

GM® 7.75" BORG WARNER® STYLE

MODEL#	YEAR
CAMARO	86-93
FIREBIRD	85-93
TRANS AM	85-93

SPECIFICATIONS:

- 9 BOLT COVER
- RG DIAMETER 7.75"
- 8-7/16" X 20 LH THREADED BOLTS
- PINION DIAMETER 1.376" 27 SPLINES
- CASES: 3.07 & NUMERICALLY HIGHER 8620 Material - Heat Treated

MOTIVE GEAR® R&P			
MG#	OEM REF#	TEETH	RATIO
GM9-370			3.70

GM® 7.75" BORG WARNER® STYLE INSTALLATION KITS & KIT COMPONENTS

DESCRIPTION	INSTALLATION KIT NO.	BEARING KIT NO.	MASTER KIT NO.	SUPER KIT NO.
BORG WARNER® STYLE 9 BOLT REAR 1986-93 CAMARO 1985-93 FIREBIRD/TRANS AM	GM7.75IK	R7.75R R7.75RT*	R7.75RMK R7.75RMKT*	N/A N/A

*KIT CONTAINS TIMKEN® BEARINGS

DESCRIPTION	PINION SHIMS	CARRIER SHIMS	CRUSH SLEEVE	PINION SEAL	PINION NUT	RING GEAR BOLT	COVER GASKET
GM® 7.75"	1104	1105	3507575	7457N	1508	14066913	N/A

GM® 8.0" STYLE

MODEL#	YEAR
MID-SIDE STD CAB P/U	2002-ON
SUV, 2WD & 4WD VANS, EXTENDED CAB P/U & CREW CAB P/U	

SPECIFICATIONS:

- 10 BOLT COVER
- RG DIAMETER 8.0"
- 10 - 7/16" X 20 RH THREADED BOLTS
- PINION DIAMETER 1.625" 28 SPLINES
- NO CASE BREAK

MOTIVE GEAR® R&P			
MG#	OEM REF#	TEETH	RATIO
GM8-342			3.42
GM8-373			3.73
GM8-410			4.10

GM® 8.0" STYLE INSTALLATION KITS & KIT COMPONENTS

DESCRIPTION	INSTALLATION KIT NO.	BEARING KIT NO.	MASTER KIT NO.	SUPER KIT NO.
2002-ON MID-SIZE SUV, P/U, 2WD & AWD VAN, 10 BOLT REAR	GM8IK	RG8R RG8RT*	RG8RMK RG8RMKT*	

*KIT CONTAINS TIMKEN® BEARINGS

DESCRIPTION	PINION SHIMS	CARRIER SHIMS	CRUSH SLEEVE	PINION SEAL	PINION NUT	RING GEAR BOLT	COVER GASKET
GM® 8.0	1100	1101	9785792	40006689	1260823	14066913	107276

GM® 8.20" 10 BOLT STYLE 1955 - 1964 CAR

MODEL#	YEAR
BELAIR/IMPALA/BISCAYNE	55-64
CHEVY® II	55-64
CORVETTE®	55-64
EL CAMINO	55-64
SERIES 140/210	55-64



11-5/8"
10 HOLES
IRREGULAR

MOTIVE GEAR PERFORMANCE® R&P		
MGP#	TEETH	RATIO
G884355	39-11	3.55
G884370	37-10	3.70
G884411X*	37-9	4.11

* FITS 3.70 AND NUMERICALLY LOWER CASE.

SPECIFICATIONS:

- RG DIAMETER 8.20"
- 10 7/16" X 20 RH THREADED BOLTS
- PINION DIAMETER 1.438" 17 SPLINES
- CASES: 3.70 & NUMERICALLY LOWER 4.11 & NUMERICALLY HIGHER
- 3RD MEMBER
- 8620 Material - Heat Treated

GM® 8.20" 10 BOLT STYLE 1955-1964 CAR INSTALLATION KITS & KIT COMPONENTS

DESCRIPTION	INSTALLATION KIT NO.	BEARING KIT NO.	MASTER KIT NO.	SUPER KIT NO.
1955 -1964 DROP OUT	GM8.4IK	R8.4R R8.4RT*	R8.4RMK R8.4RMKT*	

*KIT CONTAINS TIMKEN® BEARINGS

DESCRIPTION	PINION SHIMS	CARRIER SHIMS	CRUSH SLEEVE	PINION SEAL	PINION NUT	RING GEAR BOLT	COVER GASKET
1955 -1964	1104	N/A	3110	6818	1260823	41221	5109

**Motive Gear
Performance®**



G884370

GM® 8.20" 10 BOLT BUICK®, OLDS®, PONTIAC® STYLE

MODEL#	YEAR
BUICK® FULL SIZE	64-71
FIREBIRD	67-71
OLDS® F85	64-71
PONTIAC® FULL SIZE	64-71
TEMPEST GTO	64-71



10-5/8"
10 HOLES
IRREGULAR

MOTIVE GEAR PERFORMANCE® R&P		
MGP#	TEETH	RATIO
BP882355	39-11	3.55
BP882373	41-11	3.73
BP882390	39-10	3.90
BP882411	37-9	4.11

SPECIFICATIONS:

- RG DIAMETER 8.20"
 - 10 3/8" X 20 RH THREADED BOLTS
 - PINION DIAMETER 1.438" 27 SPLINES
 - B, P & O AXLES ONLY
 - CASES: 3.23 & NUMERICALLY LOWER
3.55 & NUMERICALLY HIGHER
- 8620 Material - Heat Treated

GM® 8.20" 10 BOLT BUICK®, OLDS®, PONTIAC® STYLE INSTALLATION KITS & KIT COMPONENTS

DESCRIPTION	INSTALLATION KIT NO.	BEARING KIT NO.	MASTER KIT NO.	SUPER KIT NO.
BOP 8.2 1964-1971	GM8.5PIK	R8.5PR R8.5PRT*	R8.5PRMK R8.5PRMKT*	

*KIT CONTAINS TIMKEN® BEARINGS

DESCRIPTION	PINION SHIMS	CARRIER SHIMS	CRUSH SLEEVE	PINION SEAL	PINION NUT	RING GEAR BOLT	COVER GASKET
GM® BOP	1104	1105	9785792	2043	1260823	14066913	5106

GM® 8.20" 10 BOLT STYLE 1964 - 1972 CAR

MODEL#	YEAR
CAMARO	67-70
CAPRICE	65-71
CHEVELLE	64-72
CHEVROLET®	65-70
CHEVY® II	64-72

MODEL#	YEAR
EL CAMINO	64-71
IMPALA	65-72
MONTE CARLO	70-72
NOVA	64-72



11" OVAL OR
10-5/8" IRREGULAR
10 HOLES

MOTIVE GEAR PERFORMANCE® R&P		
MGP#	TEETH	RATIO
G882336	37-11	3.36
G882355	39-11	3.55
G882373	41-11	3.73
G882390	39-10	3.90
G882411	37-9	4.11
G882456	41-9	4.56

SPECIFICATIONS:

- RG DIAMETER 8.20"
 - 10 3/8" X 24 RH THREADED BOLTS
 - PINION DIAMETER 1.438" 25 SPLINES
 - CASES: 3.00 & NUMERICALLY LOWER
3.08 & NUMERICALLY HIGHER
- 8620 Material - Heat Treated

SEE INSTALLATION KITS & KIT
COMPONENTS ON NEXT PAGE



GM® 8.20" 10 BOLT STYLE 1964 - 1972 CAR (CONT.)

GM® 8.20" 10 BOLT (1964-1972) CAR INSTALLATION KITS & KIT COMPONENTS

DESCRIPTION	INSTALLATION KIT NO.	BEARING KIT NO.	MASTER KIT NO.	SUPER KIT NO.
1964-1972	GM8.2IK	R10CR R10CRT*	R10CRMK R10CRMKT*	R10CRSK R10CRSKT*

*KIT CONTAINS TIMKEN® BEARINGS

DESCRIPTION	PINION SHIMS	CARRIER SHIMS	CRUSH SLEEVE	PINION SEAL	PINION NUT	RING GEAR BOLT	COVER GASKET
1964-1972 W/ OE GEAR SET	1104	1105	3106	8610	1260823	41221	5106
1964-1972 W/ AFTERMARKET GEAR SET	1104	1105	9785792	8610	1260823	41221	5106

GM® CORVETTE® STYLE 1963 - 1979

MODEL#	YEAR
CORVETTE®	63-79

MOTIVE GEAR PERFORMANCE® R&P		
MGP#	TEETH	RATIO
V885355	39-11	3.55
V885370	37-10	3.70

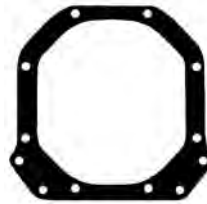

10" X 9-7/8"
8 HOLES
IRREGULAR

SPECIFICATIONS:

- RG DIAMETER 8.5"
 - 10 3/8" X 24 RH THREADED BOLTS
 - PINION DIAMETER 1.625" 30 SPLINES
 - CASES: 3.90 & NUMERICALLY LOWER
4.10 & NUMERICALLY HIGHER
- 8620 Material - Heat Treated

GM® CORVETTE® 1963-1979 INSTALLATION KITS & KIT COMPONENTS

DESCRIPTION	INSTALLATION KIT NO.	BEARING KIT NO.	MASTER KIT NO.	SUPER KIT NO.
1963-1971		R10RV R10RVT*	R10RVMK R10RVMKT*	

*KIT CONTAINS TIMKEN® BEARINGS

DESCRIPTION	PINION SHIMS	CARRIER SHIMS	CRUSH SLEEVE	PINION SEAL	PINION NUT	RING GEAR BOLT	COVER GASKET
1963-1979	1100	1101	3108	8460N	3752901	41221	5103

GM® CORVETTE® STYLE 1997 & LATER

MODEL#	YEAR
CORVETTE® C5, C6	1997-2005

SPECIFICATIONS:

- R.G. DIAMETER 8.25"
 - 10-12MM X 1.25 PITCH 1 3/4 LOW
 - PINION DIAMETER 2.535"
 - 3.14 & NUMERICALLY HIGHER
 - 2.75 & NUMERICALLY LOWER
 - TRANSAXLE TYPE
- 8620 Material - Heat Treated

MOTIVE GEAR PERFORMANCE® R&P		
MGP#	TEETH	RATIO
▶ V885342L	41-12	3.42
▶ V885373L	41-11	3.73
▶ V885390L	39-10	3.90
▶ V885390LX*	39-10	3.90
▶ V885410L	41-10	4.10
▶ V885411LX*	41-10	4.10

*Fits 2.75 & Numerically Lower Case

▶ **NOTE: 2006/07 C6 MODEL**
 WILL FIT: **LS2** W/Manual Transmission
 WILL NOT FIT: **LS2** when using Cooler Pump from **Z06**
 WILL NOT FIT: **LS2** W/Automatic Transmission (**A6**)
 WILL NOT FIT: **LS7/Z06**

GM® CORVETTE® STYLE 1997 & LATER INSTALLATION KITS & KIT COMPONENTS

DESCRIPTION	INSTALLATION KIT NO.	BEARING KIT NO.	MASTER KIT NO.	SUPER KIT NO.
C5 1997-ON		R10RVLT*	R10RVLMKT*	

*KIT CONTAINS TIMKEN® BEARINGS

GM® 8.25" IFS STYLE FRONT

MODEL#	YEAR
BLAZER/JIMMY	92-94
GM® 1/2 TON	88-ON
K15	88-ON

MODEL#	YEAR
SUBURBAN	90-ON
TAHOE/YUKON	95-ON

MOTIVE GEAR® R&P			
MG#	ALT REF#	TEETH	RATIO
G885342IFS	(GM10-342IFS)	41-12	3.42
G885373IFS	(GM10-373IFS)	41-11	3.73
G885411IFS	(GM10-411IFS)	37-9	4.11
■ GM10-430IFS	(GM10-430IFS)	43-10	4.30
■ GM10-456IFS	(GM10-456IFS)	41-9	4.56
G885488IFS	(GM10-488IFS)	39-8	4.88

SPECIFICATIONS:

- RG DIAMETER 8.25"
 - 10 7/16" X 20 LH THREADED BOLTS
 - PINION DIAMETER 1.625" 30 SPLINES
- NO CASE BREAKS
 8620 Material - Heat Treated

SEE INSTALLATION KITS
& KIT COMPONENTS ON
NEXT PAGE



GM® 8.25" IFS STYLE FRONT (CONT.)

GM® 8.25" IFS STYLE FRONT INSTALLATION KITS & KIT COMPONENTS

DESCRIPTION	INSTALLATION KIT NO.	BEARING KIT NO.	MASTER KIT NO.	SUPER KIT NO.
IFS 1988-1997	GM8.2IKF	R8.2RIFS R8.2RIFST*	R8.2RIFSMK R8.2RIFSMKT*	
IFS 1998-ON	GM8.2IKFL	R8.2RIFSL R8.2RIFSLT*	R8.2RIFSLMK R8.2RIFSLMKT*	

*KIT CONTAINS TIMKEN® BEARINGS

DESCRIPTION	PINION SHIMS	CARRIER SHIMS	CRUSH SLEEVE	PINION SEAL	PINION NUT	RING GEAR BOLT	COVER GASKET
GM® 8.25IFS	1100	1105	1234726	710101	1260823	14066913	N/A

GM® 8.5" 10 BOLT FRONT & REAR / 8.6" 10 BOLT REAR STYLE



11"
10 HOLES
IRREGULAR

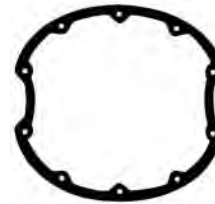

10-5/8"
10 HOLES
IRREGULAR

MODEL#	YEAR	MODEL#	YEAR	MODEL#	YEAR	MODEL#	YEAR
APOLLO/REGAL		CHEVY® FULL SIZE	71-96	GTO/FIRDBIRD/		OLDSV	71-92
CENTURY	73-77	CHEVY® II / NOVA	70/79	TRANS AM	70-81	OLDS® F-85	70-76
BISCAYNE/		CUTLASS/GRAND PRIX		GRAND NATIONAL	84-87	OMEGA	73-79
ROADMASTER	71-74	LEMANS/GTO/VENTURA/		GRAND SPORT	73-84	MONTE CARLO	71-83
BUICK® FULL SIZE	71-96	PHOENIX	71-77	HURST OLDS®	85-88	PONTIAC® FULL SIZE	71-89
CAMARO	70-81	EL CAMINO	71-77	IMPALA ROADMASTER	91-96	SKYLARK / GS	71-79
CHEVELLE	70-76	ELECTRA	73-78	LESABRE	73-74	Z-28	72-81

MODEL TRUCK	YEAR	MODEL TRUCK	YEAR
BLAZER FRONT/		GM® 3/4 TON (F)	77-99
REAR	77-91	GM® 3/4 TON (R)	79-95
C10/C15/G10/G15	78-ON	GM® 3/4 TON W/POSI (R)	77-99
G20/G25	79-ON	K10 -K15-K20-K26	
GM® 1/2 TON (F)	77-91	FRONT	77-87
GM® 1/2 TON (R)	71-ON	K10-K15 REAR	82-ON
GM® 1/2 TON W/POSI (R)	70-99		

SPECIFICATIONS:

- RG DIAMETER 8.5"
 - 10 7/16" x 20 LH THREADED BOLTS
 - PINION DIAMETER 1.626" 30 SPLINES
 - CASES: 2.56 & NUMERICALLY LOWER
2.73 & NUMERICALLY HIGHER
- 8620 Material - Heat Treated

SEE MG AND MGP RING & PINIONS PLUS
INSTALLATION KITS & KIT COMPONENTS
ON NEXT PAGE



GM® 8.5" 10 BOLT FRONT & REAR / 8.6" 10 BOLT REAR STYLE (CONT.)

MOTIVE GEAR® R&P			
MG#	OEM REF#	TEETH	RATIO
GM10-273	26018279	41-15	2.73
GM10-308	26037732	40-13	3.08
GM10-342	26037720	41-12	3.42
GM10-373	26037712	41-11	3.73
■ GM10-390		39-10	3.90
GM10-411	3988515	37-9	4.10
■ GM10-430		43-10	4.30
GM10-456	—	41-9	4.56

MOTIVE GEAR PERFORMANCE® R&P		
MGP#	TEETH	RATIO
G885273	41-15	2.73
G885308	40-13	3.08
G885342	41-12	3.42
G885373	41-11	3.73
■ G885390	39-10	3.90
G885410	41-10	4.10
■ G885430	43-10	4.30
G885456	41-9	4.56
G885488	39-8	4.88
G885513	41-8	5.13
G885538	43-8	5.38
G885557*	39-7	5.57

* SPECIAL CROSS PIN REQUIRED.
ORDER MG PART # GM10CS.
* ONLY ON 5.57

GM® 8.5" 10 BOLT FRONT & REAR / 8.6" 10 BOLT REAR STYLE INSTALLATION KITS & KIT COMPONENTS

DESCRIPTION	INSTALLATION KIT NO.	BEARING KIT NO.	MASTER KIT NO.	SUPER KIT NO.
1970-1999 FRONT(NON-IFS) & REAR CAR 1973-87 TRUCK 1988-96 TRUCK	GM8.5IK	R10R	R10RMK	R10RSK R10RASK R10RBSK
CAR 1973-87 TRUCK 1988-96 TRUCK	GM8.5IK	R10RT*	R10RMKT*	R10RSKT* R10RASKT* R10RBSKT*
1970-1999 REAR W/ EATON® POSI	GM8.5IK	R10RE R10RET*	R10REMK R10REMKT*	
1999-ON	GM8.5IKL	R10RL R10RLT*	R10RLMK R10RLMKT*	

*KIT CONTAINS TIMKEN® BEARINGS

DESCRIPTION	PINION SHIMS	CARRIER SHIMS	CRUSH SLEEVE	PINION SEAL	PINION NUT	RING GEAR BOLT	COVER GASKET
8.5 CAR & TRUCK	1100	1105	1234726	2043 / 8622	1260823	14066913	5106
8.5 & 8.6 1998-ON	1100	1101	1234726	26064028	1260823	14066913	5106

GM® 8.875" 12 BOLT STYLE CAR

MODEL#	YEAR
CHEVROLET®	64-72
CHEVY® II	65-72
CHEVELLE	64-72
CAMARO	67-72
EL CAMINO	65-72
FIREBIRD	67-72
GRAND PRIX	70-72
GTO	65-72
IMPALA	65-72
LEMANS	64-72
MONTE CARLO	70-72
NOVA	65-72
OLDS® F85	68-70

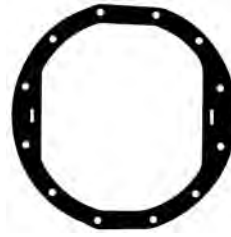

10-7/8"
12 HOLES
OVAL

SPECIFICATIONS:

- RG DIAMETER 8.875"
 - 12 3/8" X 24 RH THREADED BOLTS
 - PINION DIAMETER 1.625" 30 SPLINES
 - CASES: 3.90 & NUMERICALLY LOWER 4.10 & NUMERICALLY HIGHER
- 8620 Material - Heat Treated

MOTIVE GEAR PERFORMANCE® R&P		
MGP#	TEETH	RATIO
G888342	41-12	3.42
G888355	39-11	3.55
G888373	41-11	3.73
G888390	39-10	3.90
G888411	41-10	4.10
G888430	43-10	4.30
G888456	41-9	4.56
G888488	39-8	4.88
G888514	36-7	5.14
*FITS 3.07-3.73 CASE		

MotiveGear
Performance®

GM® 8.875" 12 BOLT STYLE CAR INSTALLATION KITS & KIT COMPONENTS

DESCRIPTION	INSTALLATION KIT NO.	BEARING KIT NO.	MASTER KIT NO.	SUPER KIT NO.
1965-1972 12 BOLT CAR	GM12IKC	R12CR R12CRT*	R12CRMK R12CRMKT*	R12CRSK R12CRSK*

*KIT CONTAINS TIMKEN® BEARINGS

DESCRIPTION	PINION SHIMS	CARRIER SHIMS	CRUSH SLEEVE	PINION SEAL	PINION NUT	RING GEAR BOLT	COVER GASKET
GM® 8.875 CAR	1100	1101	3954480	8460N	3752901	14003451	5104

GM® 8.875" 12 BOLT STYLE TRUCK

MODEL#	YEAR
1/2 TON - 3/4 TON TRUCK	64-81
G10, G15	64-81
G20, G25	69-81
K10, K15, C10, C15	64-82



11-1/2"
12 HOLES
IRREGULAR

MOTIVE GEAR® R&P		
MG#	TEETH	RATIO
GM12-308	40-13	3.08
GM12-342	41-12	3.42
GM12-373	41-11	3.73
GM12-373X *	41-11	3.73
GM12-411	37-9	4.11
GM12-411X *	37-9	4.11
GM12-456	41-9	4.56

*FITS 2.76-3.42 CASE

SPECIFICATIONS:

- RG DIAMETER 8.875"
 - 12 3/8" X 24 RH THREADED BOLTS
 - PINION DIAMETER 1.438" 30 SPLINES
 - CASES: 2.56-2.73
2.76-3.42
3.73 & NUMERICALLY HIGHER
- 8620 Material - Heat Treated

GM® 8.875" 12 BOLT STYLE TRUCK INSTALLATION KITS & KIT COMPONENTS

DESCRIPTION	INSTALLATION KIT NO.	BEARING KIT NO.	MASTER KIT NO.	SUPER KIT NO.
1963-1982 12 BOLT TRUCK	GM12IK	R12R R12RT*	R12RMK R12RMKT*	R12RSK R12RSKT*

*KIT CONTAINS TIMKEN® BEARINGS

DESCRIPTION	PINION SHIMS	CARRIER SHIMS	CRUSH SLEEVE	PINION SEAL	PINION NUT	RING GEAR BOLT	COVER GASKET
GM® 8.875 TRUCK	1104	1101	3954482	8460N	3752901	14003451	5105

GM® 9.25" IFS 14 BOLT STYLE - FRONT

MODEL#	YEAR
K2500 / K3500	1988-ON
3/4 TON	98-ON
1 TON	88-ON



10-3/16" X 11-3/16"
10 HOLES
ROUND

MOTIVE GEAR® R&P			
MG#	ALT REF#	TEETH	RATIO
G895342IFS	(GM9.25-342IFS)	41-12	3.42
G895373IFS	(GM9.25-373IFS)	41-11	3.73
G895410IFS	(GM9.25-410IFS)	41-10	4.10
G895456IFS	(GM9.25-456IFS)	41-9	4.56
G895488IFS	(GM9.25-488IFS)	39-8	4.88

SPECIFICATIONS:

- RG DIAMETER 9.25"
 - 12 MM X 1.5 LH THREADED BOLTS
 - PINION DIAMETER 1.438" 30 SPLINES
 - CASES: NO CASE BREAKS
- 8620 Material - Heat Treated

SEE INSTALLATION KITS
& KIT COMPONENTS ON
NEXT PAGE



GM® 9.25" IFS 14 BOLT STYLE - FRONT (CONT.)

GM® 9.25" IFS 14 BOLT STYLE - FRONT INSTALLATION KITS & KIT COMPONENTS

DESCRIPTION	INSTALLATION KIT NO.	BEARING KIT NO.	MASTER KIT NO.	SUPER KIT NO.
IFS 1988-1998	GM9.2IKF	R9.2RIFS R9.2RIFST*	R9.2RIFSMK R9.2RIFSMKT#	
IFS 1998-ON	GM9.2IKFL	R9.2RIFSL R9.2RIFSLT*	R9.2RIFSLMK R9.2RIFSLMKT*	

*KIT CONTAINS TIMKEN® BEARINGS

DESCRIPTION	PINION SHIMS	CARRIER SHIMS	CRUSH SLEEVE	PINION SEAL	PINION NUT	RING GEAR BOLT	COVER GASKET
GM®9.25IFS	1102	GM9.5SSK	14012691	710281	1260823	14012703	107276

GM® 9.50" 14 BOLT STYLE - REAR

MODEL#	YEAR
C10, C15, C20	88-ON
C30, C35	83-ON
K10, K15	88-ON
K20, K25	81-ON
K30, K35	89-ON
1/2 TON	88-ON
3/4 TON	81-ON
1 TON	83-95

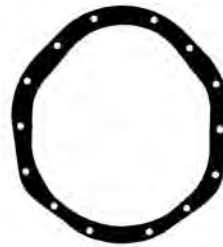

12-1/8" X 13-5/16"
14 HOLES
IRREGULAR

MOTIVE GEAR® R&P			
MG#	OEM REF#	TEETH	RATIO
GM9.5-342	26015981	41-12	3.42
GM9.5-373	26015719	41-11	3.73
GM9.5-410	26015982	41-10	4.10
GM9.5-456	14034946	41-9	4.56
GM9.5-488		39-8	4.88

SPECIFICATIONS:

- RG DIAMETER 9.5"
 - 12 12MM X 1.50" LH THREADED BOLTS
 - PINION DIAMETER 1.876 30 SPLINES
 - CASES: NO CASE BREAKS
- 8620 Material - Heat Treated

GM® 9.5" 14 BOLT STYLE REAR INSTALLATION KITS & KIT COMPONENTS

DESCRIPTION	INSTALLATION KIT NO.	BEARING KIT NO.	MASTER KIT NO.	SUPER KIT NO.
1981-1997 14 BOLT	GM9.5IK	R9.5GR R9.5GRT*	R9.5GRMK R9.5GRMKT*	
1998-ON 14 BOLT	GM9.5IK	R9.5GRL R9.5GRLT*	R9.5GRLMK R9.5GRLMKT*	

*KIT CONTAINS TIMKEN® BEARINGS

DESCRIPTION	PINION SHIMS	CARRIER SHIMS	CRUSH SLEEVE	PINION SEAL	PINION NUT	RING GEAR BOLT	COVER GASKET
GM®9.5	1102	GM9.5SSK	14012691	3896	1260823	14012703	5126

GM® 10.5" 14 BOLT STYLE

MODEL#	YEAR
3/4 TON	73-ON
1 TON	72-ON

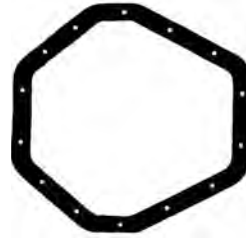

14-7/8" X 13"
14 HOLES
IRREGULAR

MOTIVE GEAR® R&P			
MG#	OEM REF#	TEETH	RATIO
GM10.5-373	327721	41-11	3.73
GM10.5-410	26029468	45-11	4.10
GM10.5-456	26026100	41-9	4.56
GM10.5-456X*		41-9	4.56
GM10.5-488	26054987	39-8	4.88
GM10.5-488X*		39-8	4.88
GM10.5-513X*		41-8	5.13
*FITS 4.10 & DOWN CASE			

SPECIFICATIONS:

- RG DIAMETER 10.5"
 - 12 9/16" X 18 RH THREADED BOLTS
 - PINION DIAMETER 1.750" 30 SPLINES
 - CASES: 4.10 & NUMERICALLY LOWER
4.56 & NUMERICALLY HIGHER
- 8620 Material - Heat Treated

GM® 10.5" 14 BOLT STYLE INSTALLATION KITS & KIT COMPONENTS

DESCRIPTION	INSTALLATION KIT NO.	BEARING KIT NO.	MASTER KIT NO.	SUPER KIT NO.
1ST DESIGN 1972-1988 W/ HM803110/49 INNER PINION BEARINGS	GM10.5IK [^]	R14R	R14RMKH [^]	
	GM10.5IK-2 ^{^^}		R14RMKL ^{^^}	
		R14RT*	R14RMKHT ^{^*}	R14RMKLT ^{^^*}
2ND DESIGN 1988-1997 W/ HM903210/49 INNER PINION BEARINGS	GM10.5IKL [^]	R14RLR	R14RLMKL ^{^^}	
	GM10.5IKL-2 ^{^^}		R14RLMKH [^]	
		R14RLT*	R14RLMKHT ^{^*}	R14RLMKLT ^{^^*}
3RD DESIGN 1998-ON	GM10.5IKLA [^]	R14RLA	R14RLAMKH [^]	
	GM10.5IKLA-2 ^{^^}		R14RLAMKL ^{^^}	
		R14RLAT*	R14RLAMKHT ^{^*}	R14RLAMKLT ^{^^*}

[^] FOR 4.10 & NUMERICALLY LOWER

^{^^} FOR 4.56 & NUMERICALLY HIGHER

* KIT CONTAINS TIMKEN® BEARINGS

DESCRIPTION	PINION SHIMS	CARRIER SHIMS	CRUSH SLEEVE	PINION SEAL	PINION NUT	RING GEAR BOLT	COVER GASKET
1973-1988	GM14SK	N/A	3977355	2286	15994582	331421 USE FOR 4.56-UP 331422 USE FOR 4.10-DN	3977387
1989 - 19997	GM14SK	N/A	26008741	2286	15994582	331421 USE FOR 4.56-UP 331422 USE FOR 4.10-DN	3977387
1998-ON	GM14SK	N/A	26008741	26064030	15994582	331421 USE FOR 4.56-UP 331422 USE FOR 4.10-DN	

GM® 11.5" STYLE

MODEL#	YEAR
C/K TRUCK	
G VAN, P TRUCK	
1 TON ALL	2001-ON

MOTIVE GEAR® R&P			
MG#	OEM REF#	TEETH	RATIO
GM11.5-373	12471452	41-11	3.73
GM11.5-410	12471453	41-10	4.10
■ GM11.5-456		41-9	4.56
GM11.5-463	40005991	37-8	4.63
GM11.5-488		39.8	4.88

SPECIFICATIONS:

- RG DIAMETER 11.5"
 - 12 9/16 X 18 RH THREADED BOLTS
 - PINION DIAMETER 2.005" 30 SPLINES
 - CASES: 4.10 & NUMERICALLY LOWER
4.63 & NUMERICALLY HIGHER
- 8620 Material - Heat Treated

GM® 11.5" STYLE INSTALLATION KITS & KIT COMPONENTS

DESCRIPTION	INSTALLATION KIT NO.	BEARING KIT NO.	MASTER KIT NO.	SUPER KIT NO.
2001-ON 1 TON C/K SERIES, G VAN, P TRUCK		R11.5R R11.5RT*	R11.5RMK R11.5RMKT*	

*KIT CONTAINS TIMKEN® BEARINGS

DESCRIPTION	PINION SHIMS	CARRIER SHIMS	CRUSH SLEEVE	PINION SEAL	PINION NUT	RING GEAR BOLT	COVER GASKET
1998-ON	GM14SK	N/A	12471647	26064030	40003027	26064505	107276

TOYOTA® 7.5" IFS STYLE

MODEL#	YEAR
TOYOTA® 4X4 LIGHT TRUCK (F)	79-ON
INDEPENDENT FRONT SUSPENSION	

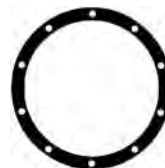

8-3/8" X 9-3/32"
10 HOLES
ROUND

MOTIVE GEAR® R&P		
MG#	TEETH	RATIO
T411IFS	41-10	4.11
T456IFS	41-9	4.56
T488IFS	39-8	4.88
T529IFS	37-7	5.29
T571IFS	40-7	5.71

SPECIFICATIONS:

- RG DIAMETER 7.5"
 - 10 7/16" X 20 RH THREADED BOLTS
 - PINION DIAMETER 1.3785" 23 SPLINES
 - CASES: NO CASE BREAKS
- 8620 Material - Heat Treated

TOYOTA® 7.5" IFS STYLE INSTALLATION KITS & KIT COMPONENTS

DESCRIPTION	INSTALLATION KIT NO.	BEARING KIT NO.	MASTER KIT NO.	SUPER KIT NO.
IFS 1986-ON	TOYKIFS	R11RIF R11RIFT*	R11RIFMK R11RIFMKT*	

*KIT CONTAINS TIMKEN® BEARINGS

DESCRIPTION	PINION SHIMS	CARRIER SHIMS	CRUSH SLEEVE	PINION SEAL	PINION NUT	RING GEAR BOLT	COVER GASKET
T7.5" IFS	1109	1130	3121	1177	1504	TOY1308	107276

TOYOTA® 7.8" STYLE

MODEL#	YEAR
TOYOTA® 4X4 LIGHT TRUCK (F&R)	79-85
4X4 (R)	86-96



8-3/8" X 9-3/32"
10 HOLES
ROUND

MOTIVE GEAR® R&P		
MG#	TEETH	RATIO
T390	39-10	3.90
T411	41-10	4.11
T456	41-9	4.56
T488	39-8	4.88
T529	37-7	5.29
T571	40-7	5.71

SPECIFICATIONS:

- RG DIAMETER 7.8"
- 10 7/16" X 20 RH THREADED BOLTS
- PINION DIAMETER 1.3785" 27 SPLINES
- CASES: NO CASE BREAKS
- 10 BOLT 3rd MEMBER
- 8620 Material - Heat Treated

TOYOTA® 7.8" STYLE INSTALLATION KITS & KIT COMPONENTS

DESCRIPTION	INSTALLATION KIT NO.	BEARING KIT NO.	MASTER KIT NO.	SUPER KIT NO.
1969-1987 4X4 TRUCK 4 CYL. NON-TURBO	TOYIK	R11R R11RT*	R11RMK R11RMKT*	

*KIT CONTAINS TIMKEN BEARINGS

DESCRIPTION	PINION SHIMS	CARRIER SHIMS	CRUSH SLEEVE	PINION SEAL	PINION NUT	RING GEAR BOLT	COVER GASKET
TOYOTA® 7.8	1109	N/A	3114	1177	1504	TOY1308	107276

TOYOTA® 7.8" V6 AND TURBO STYLE

MODEL#	YEAR
TOYOTA® P/U - 4 RUNNER	
4 CYL. TURBO, V6	87-95

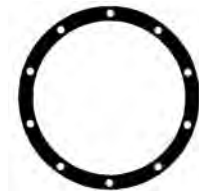

8-3/8" X 9-3/32"
10 HOLES
ROUND

MOTIVE GEAR® R&P		
MG#	TEETH	RATIO
T390	39-10	3.90
T390V6	39-10	3.90
T411V6	41-10	4.11
T456V6	41-9	4.56
T488V6	39-8	4.88
T529V6	37-7	5.29
T571V6	40-7	5.71

SPECIFICATIONS:

- RG DIAMETER 7.8"
- 10 - 11 X 1.00MM RH THREADED BOLTS
- PINION DIAMETER 1.3785" 27 SPLINES
- CASES: NO CASE BREAKS
- 10 BOLT 3RD MEMBER
- 8620 Material - Heat Treated

TOYOTA® 7.8" V6 & TURBO STYLE INSTALLATION KITS & KIT COMPONENTS

DESCRIPTION	INSTALLATION KIT NO.	BEARING KIT NO.	MASTER KIT NO.	SUPER KIT NO.
1986-ON V6 & 4 CYL. TURBO	TOYV6IK	R11RV6 R11RV6T*	R11RV6MK R11RV6MKT*	

*KIT CONTAINS TIMKEN® BEARINGS

DESCRIPTION	PINION SHIMS	CARRIER SHIMS	CRUSH SLEEVE	PINION SEAL	PINION NUT	RING GEAR BOLT	COVER GASKET
T7.8V6	1109	N/A	3122	1177	1504	TOY1308	107276

TOYOTA® LANDCRUISER® - FRONT IFS STYLE

MODEL#	YEAR
LANDCRUISER	90-97



8-3/8" X 9-3/32"
10 HOLES
ROUND

MOTIVE GEAR® R&P		
MG#	TEETH	RATIO
T456LIFS	41-9	4.56

SPECIFICATIONS:

- RG DIAMETER 8"
- 10 - 11 X 1.00MM RH THREADED BOLTS
- PINION DIAMETER 1.378 - 27 SPLINES
- CASES: NO CASE BREAKS
- 10 BOLT 3RD MEMBER
- 8620 Material - Heat Treated

TOYOTA® LANDCRUISER STYLE

MODEL#	YEAR
LANDCRUISER	68-89

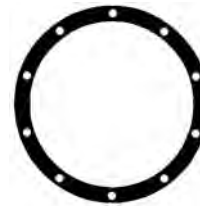

8-3/8" X 9-3/32"
10 HOLE
ROUND

MOTIVE GEAR® R&P		
MG#	TEETH	RATIO
T370L	37-10	3.70
T411L	41-10	4.11
T456L	41-9	4.56
T488L	39-8	4.88

SPECIFICATIONS:

- 9.5" RG DIAMETER
- 12 12mm X 1.00 RH THREADED BOLTS
- PINION DIAMETER 1.575" 27 SPLINES
- CASES: NO CASE BREAKS
- 10 BOLT 3rd MEMBER
- 8620 Material - Heat Treated

NOTE: SOME LATER APPLICATIONS MAY REQUIRE PURCHASE OF FACTORY BOLT & NUT KIT.

TOYOTA® LANDCRUISER STYLE - FRONT & REAR INSTALLATION KITS & KIT COMPONENTS

DESCRIPTION	INSTALLATION KIT NO.	BEARING KIT NO.	MASTER KIT NO.	SUPER KIT NO.
1969-2002 REAR	N/A	R11RLC	N/A	N/A
1969-1990 FRONT STRAIGHT AXLE	N/A	R11RLC	N/A	N/A

*KIT CONTAINS TIMKEN® BEARINGS

Motive Gear®

TOYOTA® TACOMA & T100™ REAR STYLE

MODEL#	YEAR
TACOMA	95-ON
TUNDRA (R)	95-ON
T100 (R)	95-ON
SEQUOIA	95 1/2-ON



8-3/8" X 9-3/32"
10 HOLES
ROUND

MOTIVE GEAR® R&P		
MG#	TEETH	RATIO
TAC456	41-9	4.56
TAC488	39-8	4.88
TAC529	37-7	5.29

SPECIFICATIONS:

- 8 1/4" RG DIAMETER
- 12 12MM X 1.00 RH RG BOLTS
- PINION DIAMETER 1.580" 30 SPLINES
- CASES: 3.50 & DOWN - 3.70 & UP
- 8620 Material - Heat Treated

TOYOTA® TACOMA & T100™ REAR STYLE INSTALLATION KITS & KIT COMPONENTS

DESCRIPTION	INSTALLATION KIT NO.	BEARING KIT NO.	MASTER KIT NO.	SUPER KIT NO.
1993-1996 TACOMA 4 CYL. 2 WD POSI	N/A	R11RA	N/A	N/A
1993-1999 TACOMA 4 & 6 CYL. 4WD OPEN	N/A	R11RC	N/A	N/A
1996-1999 TACOMA 4 CYL. 2WD OPEN	N/A	R11RD	N/A	N/A
1993-1995 TACOMA 4 CYL. 2WD OPEN	N/A	R11RE	N/A	N/A
1997-1999 TACOMA 4 & 6 CYL. 4WD POSI	N/A	R11RF	N/A	N/A
1993-1996 TACOMA 4 & 6 CYL. 4WD POSI	N/A	R11RG	N/A	N/A

*KIT CONTAINS TIMKEN® BEARINGS

TOYOTA® TACOMA - FRONT STYLE

MODEL#	YEAR
TACOMA	95 1/2-ON
TUNDRA	95 1/2-ON
SEQUOIA	95 1/2-ON

MOTIVE GEAR® R&P		
MG#	TEETH	RATIO
TAC456	41-9	4.56
TAC456IFS	41-9	4.56
TAC488IFS	39-8	4.88
TAC529IFS	37-7	5.29

SPECIFICATIONS:

- 7 1/2" RG DIAMETER
- 10MM X 1.00 RH RG BOLTS
- PINION DIAMETER 1.378" 23 SPLINES
- 8620 Material - Heat Treated

TOYOTA® TACOMA - FRONT STYLE INSTALLATION KITS & KIT COMPONENTS

DESCRIPTION	INSTALLATION KIT NO.	BEARING KIT NO.	MASTER KIT NO.	SUPER KIT NO.
TACOMA FRONT IFS	N/A	R11RTACF	R11RTACFMK	N/A

*KIT CONTAINS TIMKEN® BEARINGS

Choose The Gear Ratio That Is Best For Your Vehicle

When selecting a Gear Ratio, you should consider the following:

1. Tire Size
2. Transmission Ratio
3. Final Gear Ratio
4. Engine RPM at Cruise Speed

The following formula has been developed to calculate the optimum final Gear Ratio to suit your application.

$$\frac{\text{M.P.H.} \times \text{Gear Ratio}}{\text{Tire Diameter}} \times 336 = \text{rpm}$$

The chart shown below shows **RPM calculations at 55 MPH** for various combinations of final Gear Ratio and Tire Diameter.

- ▶ **ACCEPTABLE RPM RANGE:** 2000-3000 (represented by the entire shaded area of the chart).
- ▶ **OPTIMUM RPM RANGE:** 2300-2600 (represented by the yellow shading in the chart).
- ▶ **CHANGING RATIOS TO IMPROVE MILEAGE:** Choose a ratio within the orange shaded band above the optimum range.
- ▶ **CHANGING RATIOS TO IMPROVE POWER:** Choose a ratio within the orange shaded band below the optimum range.

Gear Ratio	Tire Diameter																
	24	25	26	27	28	29	30	31	32	33	34	35	36	38	40	42	44
2.56	1972	1892	1820	1752	1690	1631	1577	1526	1478	1434	1391	1352	1314	1245	1183	1126	1075
2.73	2102	2018	1940	1869	1802	1740	1682	1627	1577	1529	1484	1441	1401	1328	1261	1201	1147
2.94	2264	2173	2090	2012	1942	1874	1811	1753	1698	1646	1599	1552	1509	1429	1358	1294	1235
3.08	2372	2277	2189	2108	2033	1963	1897	1836	1779	1725	1674	1626	1581	1498	1423	1355	1294
3.21	2472	2373	2282	2197	2119	2046	1977	1914	1854	1798	1745	1695	1648	1561	1483	1412	1348
3.31	2549	2447	2353	2266	2185	2110	2039	1973	1912	1854	1799	1748	1699	1610	1529	1456	1390
3.42	2633	2528	2303	2341	2257	2179	2107	2039	1975	1915	1859	1806	1756	1663	1580	1505	1436
3.54	2726	2617	2516	2423	2336	2256	2181	2110	2044	1982	1924	1869	1817	1772	1635	1558	1487
3.73	2872	2757	2651	2553	2462	2377	2298	2224	2154	2089	2027	1969	1915	1814	1723	1641	1567
3.90	3003	2883	2772	2669	2574	2485	2402	2325	2252	2184	2120	2059	2002	1897	1802	1716	1638
4.10	3157	3031	2914	2806	2706	2613	2526	2444	2368	2296	2228	2165	2105	1994	1894	1804	1722
4.27	3288	3156	3035	2923	2818	2721	2630	2545	2466	2391	2321	2255	2192	2077	1973	1879	1793
4.56	3511	3371	3291	3121	3010	2906	2809	2718	2633	2554	2478	2408	2341	2218	2107	2006	1915
4.88	3758	3607	3469	3340	3221	3110	3006	2909	2818	2733	2652	2577	2505	2373	2255	2147	2050
5.29	4073	3910	3760	3621	3491	3371	3259	3154	3055	2962	2875	2793	2716	2573	2444	2328	2222
5.38	4143	3977	3824	3682	3551	3428	3314	3207	3107	3013	2924	2841	2762	2616	2486	2367	2260
5.71	4397	4221	4058	3908	3769	3639	3517	3404	3298	3198	3104	3015	2931	2777	2638	2512	2398
6.17	4751	4561	4385	4223	4072	3932	3801	3678	3563	3455	3354	3258	3167	3001	2851	2715	2591
7.17	5521	5300	5096	4907	4732	4569	4417	4274	4141	4015	3897	3786	3681	3487	3313	3155	3011



Find Your Power

When you need less rotating weight with faster acceleration and higher speeds, you need the MOTIVE GEAR® AX High Performance ring & pinion!

- ▶ Up to 2 lbs. of rotating weight removed
- ▶ Computer controlled heat treatment
- ▶ Solid shank pinion shaft



AX

WIN WITH MOTIVE GEAR!

Engineered to outperform the competition!



Motive Gear Performance®

The Performance Division of Midwest Truck & Auto Parts, Inc.™

Motive Gear Performance proudly sponsors Robin Lawrence (top) and Team Horse Power/Team Motive Gear

Axle Shafts



LIGHT DUTY AXLE SHAFTS - FRONT TRUCK

AMC®-JEEP® STYLE (ALL CHROME MOLY 4340)

MODEL #	MOTIVE GEAR® PART #	DESCRIPTION/STYLE	OVERALL LENGTH	U-JOINT	SIDE	SPLINE	DIAMETER
D30	MG8000	OUTER AXLE, 1987- UP YJ, TJ, X5, RUBICON STYLE	6.11"	5-297X/5-760X	L/R	27	1.16"
D30/44	MG8003	OUTER AXLE, 1972-86 CJ STYLE	8.72"	5-297X/5-760X	L/R	27	1.31"
D44	MG8001	OUTER AXLE 1974-76 WAGONEER W/ DRUM BRAKE STYLE	9.72"	5-297X/5-760X	L/R	19	1.16"
D44	MG8002	OUTER AXLE 1974-83 WAGONEER W/ DISC BRAKES STYLE	9.94"	5-297X/5-760X	L/R	19	1.16"
D30	MG9004	INNER AXLE, 1972-81 CJ5, CJ7 STYLE	14.14"	5-297X/5-760X	RH	27	1.16"
D30	MG9005	INNER AXLE, 1982-86 CJ7 STYLE	15.82"	5-297X/5-760X	RH	27	1.16"
D30	MG9008	INNER AXLE, 1987-96 - WRANGLER XJ, TJ STYLE	32.31"	5-297X/5-760X	RH	27	1.16"
D30	MG9015	INNER AXLE, 1972-81 CJ STYLE	27.01"	5-297X/5-760X	LH	27	1.16"
D30	MG9016	INNER AXLE, 1982-86 CJ7 STYLE	28.69"	5-297X/5-760X	LH	27	1.16"
D30	MG9019	INNER AXLE, 1987-ON WAGONEER STYLE	16.50"	5-297X/5-760X	LH	27	1.16"
D44	MG9003	INNER AXLE, 1974-79 WAGONEER STYLE	14.69"	5-297X/5-760X	RH	30	1.31"
D44	MG9007	INNER AXLE, 1980-92 WAGONEER STYLE	15.80"	5-297X/5-760X	RH	30	1.31"
D44	MG9017	INNER AXLE, 1974-79 WAGONEER STYLE	33.19"	5-297X/5-760X	LH	30	1.31"
D44	MG9018	INNER AXLE, 1980-84 WAGONEER STYLE	32.12"	5-297X/5-760X	LH	30	1.31"

DANA® STYLE BLANKS (ALL CHROME MOLY 4340)

MODEL #	MOTIVE GEAR® PART #	DESCRIPTION/STYLE	OVERALL LENGTH	U-JOINT	SIDE	SPLINE	DIAMETER
D44	MG9401	INNER AXLE - BLANK INNER SHAFT	22.00"	5-297X/5-760X			
D44	MG9402	INNER AXLE - BLANK INNER SHAFT	36.25"	5-297X/5-760X			

FORD® STYLE (ALL CHROME MOLY 4340)

MODEL #	MOTIVE GEAR® PART #	DESCRIPTION/STYLE	OVERALL LENGTH	U-JOINT	SIDE	SPLINE	DIAMETER
D44	MG8001	OUTER AXLE, 1971-79 BRONCO STYLE	9.72"	5-297/5-760X	L/R	19	1.16"
D60	MG8005	OUTER AXLE, 1978-79 F150 W/ DISC BRAKES STYLE	11.40"	5-332X/5-806X	L/R	35	1.50"
D44	MG9001	INNER AXLE, 1971-77 BRONCO STYLE	27.94"	5-297X/5-760X	RH	30	1.31"
D44	MG9012	INNER AXLE, 1971-77 BRONCO STYLE	18.31"	5-297X/5-760X	LH	30	1.31"
D44	MG9013	INNER AXLE, 1968-79 PICKUP, 1978-79 BRONCO STYLE	18.91"	5-297X/5-760X	LH	30	1.31"

LIGHT DUTY AXLE SHAFTS - FRONT TRUCK

FORD® STYLE STOCK REPLACEMENT

MODEL #	MOTIVE GEAR® PART #	DESCRIPTION/STYLE	OVERALL LENGTH	U-JOINT	SIDE	SPLINE	DIAMETER
D44	620200R	OUTER SHAFT 1971-77 BRONCO, 1978-79 F150 W/ DISC BRAKES STYLE	9.72"	5-297X/5-760X	L/R	19	1.25"

GMC® STYLE (ALL CHROME MOLY 4340)

MODEL # OR RING GEAR DIAM.	MOTIVE GEAR® PART #	DESCRIPTION/STYLE	OVERALL LENGTH	U-JOINT	SIDE	SPLINE	DIAMETER
D44/8.5"	MG8002	OUTER AXLE, 1974-83 1/2 TON	9.94"	5-297X/5-760X	L/R	19	1.16"
D60	MG8004	OUTER AXLE, GMC STYLE	12.00"	5-332X/5-806X	L/R	35	1.50"
D44/8.5"	MG9000	INNER AXLE, 1969-78 PICKUP, BLAZER STYLE	18.31"	5-297X/5-760X	RH	30	1.31"
D44/8.5"	MG9010	INNER AXLE, 1979-87 PICKUP, BLAZER STYLE	35.46"	5-297X/5-760X	LH	29	1.27"
D44/8.5"	MG9011	INNER AXLE, 1969-78 PICKUP STYLE	36.13"	5-297X/5-760X	LH	30	1.31"
D44/8.5"	MG9024	INNER AXLE, 1979-87 CHEVY® PICKUP, BLAZER STYLE	19.15"	5-297X/5-760X	LH	30	1.31"

GMC® STYLE STOCK REPLACEMENT

MODEL # OR RING GEAR DIAM.	MOTIVE GEAR® PART #	DESCRIPTION/STYLE	OVERALL LENGTH	U-JOINT	SIDE	SPLINE	DIAMETER
D44/8.5"	41677R	OUTER AXLE, 1979-87 1/2 TON & PICKUP STYLE	9.94"	5-297X/5-760X	L/R	28	1.16"
D44/8.5"	29903-1XR	INNER AXLE SHAFT, 1979-87 1/2 TON & PICKUP STYLE	19.15"	5-297X/5-760X	RH	28	1.27"
D44/8.5"	660276-1R	INNER AXLE SHAFT, 1979-87 1/2 TON & PICKUP STYLE	35.46"	5-297X/5-760X	LH	28	1.27"
D44/8.5"	* GM10FAXL	AXLE KIT 1979-87 1/2 TON & PICKUP	45.40"	5-297X/5-760X	LH	28	1.27"
D44/8.5"	* GM10FAXR	AXLE KIT 1979-87 1/2 TON & PICKUP	29.09"	5-297X/5-760X	RH	28	1.27"

* Kit includes Inner Axle, Outer Axle & U-Joint

IHC® STYLE (ALL CHROME MOLY 4340)

MODEL #	MOTIVE GEAR® PART #	DESCRIPTION/STYLE	OVERALL LENGTH	U-JOINT	SIDE	SPLINE	DIAMETER
D30/44	MG8003	1973-80 INTL SCOUT II STYLE	14.78"	5-297X/5-760X	R/L	27	1.31"
D44	MG9006	1971-80 INTL SCOUT II STYLE	14.78"	5-297X/5-760X	RH	30	1.31"
D44	MG9014	1971-80 INTL SCOUT II STYLE	32.91"	5-297X/5-760X	LH	30	1.31"

LIGHT DUTY AXLE SHAFTS - REAR CAR

FORD® STYLE

RING GEAR DIAM.	MOTIVE GEAR® PART #	CROSS REF. OEM PART #	CROSS REF. HOLLANDER® PART #	DESCRIPTION/STYLE	OVERALL LENGTH	2/4 WD	# OF LUGS	SIDE L/R	SPLINE COUNT
7.5/8.8"	MG7430	D9AZ4234A	1227	1979-89 MERCURY® PASSENGER CAR STYLE	30 7/8"	2	5	L/R	28
7.5/8.8"	F8AZ4234DA	F2AZ4234DA	2307	1998-02 CROWN VICTORIA TOWN CAR - ABS STYLE	32 7/16"	2	5	L/R	28
7.5/8.8"	MG2010	XR3Z4234AA	2425	1999-2002 MUSTANG ABS STYLE	30 5/8"	2	5	L/R	28
8.8"	3W1Z4234KA	3W1Z4234KA	2733	2003-2006 CROWN VICTORIA, GRAND MARQUIS STYLE	34 7/16"	2	5	L/R	31
8.8"	F2AZ4234B	F2AZ4234B	1824	1992-97, LINCOLN® MERCURY® ABS 1991-98 CROWN VICTORIA STYLE	31 3/4"	2	5	L/R	28
8.8"	F2AZ4234C	F2AZ4234C	1823	1992-97, LINCOLN® MERCURY® - W/O ABS, 1991-98 CROWN VICTORIA STYLE	31 3/4"	2	5	L/R	28
8.8"	MG1231	D9BZ4234C	1231	1979-93 MUSTANG STYLE	29"	2	4	L/R	28
8.8"	MG2006	F4ZZ4234B	2006	1994-98 MUSTANG ABS STYLE	29 15/16"	2	5	L/R	28
8.8"	MG2007	F4ZZ4234A	2007	1994-98 MUSTANG W/O ABS STYLE	29 15/16"	2	5	L/R	28

GMC® STYLE

RING GEAR DIAM.	MOTIVE GEAR® PART #	CROSS REF. OEM PART #	CROSS REF. HOLLANDER® PART #	DESCRIPTION/STYLE	OVERALL LENGTH	2/4 WD	# OF LUGS	SIDE L/R	SPLINE COUNT
7.5	22504959	22504959	1206	1977-85 FULL SIZE CAR APPLICATIONS	30 1/2"	2	5	L/R	26
7.5"	22506477	22506477	1137	1982-90 CAPRICE, 1982-86 OLDS® CUSTOM, 1983-86 PONTIAC® PERISIENNE STYLE	30 1/2"	2	5	L/R	26
7.5"	22512850	22512850	1309	1982-87 MID-SIZE CAR	28.5"	2	5	L/R	26
7.5"	22515441	22515441	1302	1982-87 CAMARO/FIREBIRD W/DRUM STYLE	30 5/16"	2	5	L/R	26
7.5"	26019539	26019539	1870	1991-92 CAPRICE STYLE	30 1/8"	2	5	L/R	26
7.5"	26059962	26059962	2343	1998-2001 CAMARO/FIREBIRD W/O TRACTION CONTROL STYLE	32"	2	5	L/R	28
7.5"	26059972	26059972	2342	1998-2001 CAMARO/FIREBIRD W/ TRACTION CONTROL STYLE	32"	2	5	L/R	28
7.5"	551818	551818	1208	1978-81 MID-SIZE CAR	28.5"	2	5	L/R	26
7 5/8"	MG1021	26027588	1960/961	1993-96 CAMARO/FIREBIRD STYLE	32"	2	5	L/R	28
7.6"	MG1020	26031252	1776/1777	1990-92 CAMARO/FIRDBIRD STYLE	30 5/16"	2	5	L/R	28
8.2"	MG1010	1255803	787	1967-69 CAMARO, 1970-75 NOVA, 1965-67 CHEVELLE STYLE	29 5/8"	2	5	L/R	28
8.2"	MG1015	1255802	912	1970-81 CAMARO STYLE 1968-72 CHEVELLE & EL CAMINO STYLE	30 1/8"	2	5	L/R	28
8.5"	1255801	1255801	1067	1977-87 VARIOUS INTERMEDIATE GM®	30 7/16"	2	5	L/R	28
8.5"	25501599	25501599	1205	1983-88 CAPRICE, 1986-88 CADILLAC® DEVILLE, 1979-80 LESABRE STYLE	30 7/16"	2	5	L/R	28
8.5"	26014036	26014036	1668	1989-90 PASSENGER CAR	30 1/2"	2	5	L/R	30
8.5"	26014037	26014037	1664	1989-90 CADILLAC® STYLE	30 7/16"	2	5	L/R	30
8.5"	26018080	26018080	1858	1991-96 CAPRICE W/DISC BRAKES STYLE 1991-92 CADILLAC® RWD STYLE 1991-96 BUICK® STYLE	30 3/8"	2	5	L/R	30
8.5"	26038684	26038684	2048	1994-96 CAPRICE STYLE 1994-96 IMPALA W/DISC BRAKES	30 5/16"	2	5	L/R	30

LIGHT DUTY AXLE SHAFTS - REAR CAR

GMC® STYLE (CONT.)

RING GEAR DIAM.	MOTIVE GEAR® PART #	CROSS REF. OEM PART #	CROSS REF. HOLLANDER® PART #	DESCRIPTION/STYLE	OVERALL LENGTH	2/4 WD	# OF LUGS	SIDE L/R	SPLINE COUNT
8.875"	MG1000	3969285	913	1968-72 CHEVELLE & EL CAMINO STYLE 1970-72 CAMARO STYLE	30 1/16"	2	5	L/R	30
8.875"	MG1005	3969349	788	1968-72 CHEVY® II, 1967-69 CAMARO STYLE 1965-67 CHEVELLE STYLE	29 9/16"	2	5	L/R	30

#1 Source
for diesel performance gearing

Motive Gear®

Motive Gear supplies **over 70** diesel gearing ratios for the following applications:

- ▶ Dana® Style 50, 60, 70 & 80
- ▶ Dodge® Style 9.25 Rear
- ▶ Dodge® Style Trucks-10.5 Rear
- ▶ Dodge® Style Trucks-9.25 Front
- ▶ Dodge® Style Trucks-11.5 Rear
- ▶ Ford® Style 9.75 Rear
- ▶ Ford® Style 10.25 Rear (early)
- ▶ Ford® Style 10.25 Rear (late)
- ▶ Ford® Style 10.5 Rear
- ▶ GM® Style 9.25 Front
- ▶ GM® Style 9.5 Rear
- ▶ GM® Style 10.5 Rear
- ▶ GM® Style 11.5 Rear

LIGHT DUTY AXLE SHAFTS - REAR TRUCK

AMC®-JEEP® STYLE

MODEL#	MOTIVE GEAR® PART #	CROSS REF. OEM PART #	CROSS REF. HOLLANDER® PART #	DESCRIPTION/STYLE	OVERALL LENGTH	2/4 WD	# OF LUGS	SIDE L/R	SPLINE COUNT
AM20	3150046K			AXLE BEARING KIT FOR 2 PC. AXLE - (CUP & CONE, NUT & KEY & SEALS)					
AM20	8127070	8127070		2 PC. AXLE CJ 1976-82 STYLE	26 1/4"	4	5	LH	29
AM20	8127071	8127071		2 PC. AXLE CJ 1976-82 STYLE	29"	4	5	RH	29
AM20	8127079	8127079		1976-86 ALL CJ W/QUADRATRAC T/C STYLE	33 1/2"	4	5	LH	29
AM20	8127081	8127081		1976-86 ALL CJ W/QUADRATRAC T/C STYLE	22"	4	5	RH	29
AM20	8133730			AXLE HUB ASSEMBLY FOR 2 PC. AXLE					
AM20	8133885	8133885		2 PC. AXLE CJ 1982-86 STYLE	28 1/2"	4	5	LH	29
AM20	8133886	8133886		2 PC. AXLE CJ 1982-86 STYLE	31 1/2"	4	5	RH	29
AM20	* AM20CJE			1976-82 1 PC. AXLE KIT CJ STYLE		4	5	PAIR	29
AM20	* AM20CJL			1983-86 1 PC. AXLE KIT CJ STYLE		4	5	PAIR	29
AM20	* AM20Q			1976-86 CJ 1 PC. AXLE KIT W/QUADRATRAC T/CASE STYLE		4	5	PAIR	29
C8.25	53008134	53008134	1831	1991-96 CHEROKEE STYLE	29 13/16"	2/4	5	L/R	27
C8.25	MG5020	5018393	2235	1997-2001 CHEROKEE STYLE	29 3/4"	4	5	L/R	29
D35	72912-1X	72912-1X	1799R	1988-89 CHEROKEE, WAGONEER ABS STYLE	28 15/16"	4	5	RH	27
D35	72912-2X	72912-2X	1799L	1988-89 CHEROKEE, WAGONEER ABS STYLE	30 9/16"	4	5	LH	27
D35	73624-1XR	73624-1X	1797R	1990-92 CHEROKEE WAG. WRANGLER STYLE	29 1/16"	4	5	RH	27
D35	73624-2XR	73624-2X	1797L	1990-92 CHEROKEE WAG. WRANGLER STYLE	30 9/16"	4	5	LH	27
D35	74356-1X	74356-1X	1832R	1993-98 CHEROKEE, WRANGLER - NON-ABS STYLE	29 1/16"	4	5	RH	27
D35	74356-2X	74356-2X	1832L	1993-98 CHEROKEE, WRANGLER - NON-ABS STYLE	30 9/16"	4	5	LH	27
D35	74789-1XR	74789-1X	2081R	1994-98 GRAND CHEROKEE, ABS. DISC STYLE	29 1/8"	4	5	RH	27
D35	74789-2XR	74789-2X	2081L	1994-98 GRAND CHEROKEE, ABS. DISC STYLE	30 9/16"	4	5	LH	27
D35	76467-3X	76467-3X	2461	1999-2001 GRAND CHEROKEE STYLE		4	5	RH	27
D35	76467-4X	76467-4X	2462	1999-2001 GRAND CHEROKEE STYLE	31 7/8"	4	5	LH	27
D44	73499-1X	73499-1X	1567R	1987-89 CHEROKEE WAGON STYLE 1987-92 COMMANCHE STYLE	29 1/4"	4	5	RH	30
D44	73499-2X	73499-2X	1567R	1987-89 CHEROKEE WAGON STYLE 1987-92 COMMANCHE STYLE	29 3/4"	4	5	LH	30
D44	74871-1XR	74871-1X	2232R	1996-98 GRAND CHEROKEE, ABS. DISC STYLE	29 1/4"	4	5	RH	30
D44	74871-2XR	74871-2X	2232L	1996-98 GRAND CHEROKEE, ABS. DISC STYLE	30 1/4"	4	5	LH	30
D44	75786-1X	75786-1X	2416R	1997-2000 WRANGLER STYLE	29 11/16"	4	5	RH	30
D44	75786-2X	75786-2X	2416L	1997-2000 WRANGLER STYLE	29 1/4"	4	5	LH	30
D44	76454-1X	76454-1X	2703R	1999-2002 GRAND CHEROKEE - W/ VERI-LOC STYLE	29 3/8"	4	5	RH	30
D44	76454-2X	76454-2X	2704L	1999-2002 GRAND CHEROKEE - W/ VERI-LOC STYLE	32 3/8"	4	5	LH	30
D44	76454-3X	76454-3X	2705R	1999-2001 GRAND CHEROKEE STYLE	30 7/16"	4	5	RH	30
D44	76454-4X	76454-4X	2706L	1999-2001 GRAND CHEROKEE STYLE	31 7/16"	4	5	LH	30

* Kit includes Left & Right Axle Shafts, Bearings, Seals, and Studs



LIGHT DUTY AXLE SHAFTS - REAR TRUCK

CHRYSLER®-DODGE®-PLYMOUTH® STYLE

RING GEAR DIAM.	MOTIVE GEAR® PART #	CROSS REF. OEM PART #	CROSS REF. HOLLANDER® PART #	DESCRIPTION/STYLE	OVERALL LENGTH	2/4 WD	# OF LUGS	SIDE L/R	SPLINE COUNT
7.25"	MG1552	4348511	1552	1987-90 DAKOTA STYLE	30 1/4"	2	5	L/R	25
7.25"	MG1901	4506147	1901	1991-96 DAKOTA STYLE	30 1/4"	2	5	L/R	25
8.25"	4137828	4137828	1074	VARIOUS 73-83 PASSENGER CAR & RAMCHARGER STYLE	31 5/8"	2	5	L/R	27
8.25"	4506115	4506115	1900	1991-96 DAKOTA STYLE	30 3/4"	2/4	6	L/R	27
8.25"	MG1441	4137670	1441	1985-95 DODGE® VAN 150, 250, 1500, 2500 STYLE	32 9/16"	2/4	5	L/R	27
8.25"	MG1551	4348510	1551	1987-90 DAKOTA STYLE	30 3/4"	2/4	5	L/R	27
9.25"	4037726	4037726	1289	1980-4/2/84 RAMCHARGER, TRAILDUSTER, PICKUP, 1/2 TON STYLE	31 5/8"	2/4	5	L/R	31
9.25"	4137429	4137429	1398	1985-93 RAMCHARGER 4WD PICKUP, 1/2 TON STYLE	31 5/8"	2/4	5	L/R	
9.25"	52067708	52067708	1927	1991-01 DODGE® VAN STYLE	32 9/16"	2	5	L/R	31
9.25"	52069388	52069388	2344R	1998-04 DAKOTA, 1998-03 DURANGO STYLE	30 1/14"	4	6	RH	31
9.25"	52069389	52069389	2344L	1998-04 DAKOTA, 1998-03 DURANGO STYLE	33 5/16"	4	6	LH	31
9.25"	MG1081	3723824	1081	1974-83 RAMCHARGER, CHRYSLER®, TRAILDUSTER, PICKUP, 1/2 TON STYLE	30 11/16"	2/4	5	L/R	31
9.25"	MG5000	52067614	2030	1994-2000 DODGE® 1/2 TON STYLE	34 1/8"	2/4	5	L/R	31
11.5"	40022279	40022279	2744	2003-04 DODGE® PICKUP 3/4 TON - SINGLE WHEEL STYLE	37 1/14"	2/4	8	L/R	30
11.5"	40022280	40022280	2745	2003-04 DODGE® PICKUP 1 TON DUALY STYLE	40 1/2"	2	8	L/R	30

FORD® STYLE

RING GEAR DIAM.	MOTIVE GEAR® PART #	CROSS REF. OEM PART #	CROSS REF. HOLLANDER® PART #	DESCRIPTION/STYLE	OVERALL LENGTH	2/4 WD	# OF LUGS	SIDE L/R	SPLINE COUNT
7.5"	E3TZ4234B	E3TZ4234B	1337R	1983-92 RANGER STYLE	26 1/4"	2/4	5	RH	28
7.5"	E3TZ4234C	E3TZ4234C	1338	1983-92 RANGER/BRONCO II STYLE	29 1/8"	2/4	5	LH	28
7.5"	E4TZ4234A	E4TZ4234A	1339R	1983-91 BRONCO II STYLE	27 11/16"	4	5	RH	28
7.5"	MG1409	14074822	1409R	1985-89 ASTRO VAN STYLE	30 5/16"	2	5	RH	26
7.5"	MG1456	E69Z4234A	1456L	1986-97 AEROSTAR STYLE	32 1/4"	2/4	5	LH	28
7.5/8.8"	F87Z4234AC	F87Z4234AC	2419	1999-2001 RANGER STYLE	27 1/4"	2/4	5	RH	28
7.5/8.8"	F87Z4234AD	F87Z4234AD	2420	1999-2001 RANGER STYLE	30 1/4"	2/4	5	LH	28
7.5/8.8"	MG3040	F37Z4234A	2088R	1993-97 FORD® RANGER, MAZDA® P/U STYLE	27 1/4"	2/4	5	RH	28
7.5/8.8"	MG3041	F37Z4234B	2089L	1993-97 RANGER, MAZDA® PICKUP STYLE	30 1/8"	2/4	5	LH	28
8.8"	E3TZ4234D	E3TZ4234D	1340R	1983-86 F100/F150, FULL SIZE BRONCO STYLE	31 1/16"	2/4	5	RH	31
8.8"	E3TZ4234E	E3TZ4234E	1341L	1983-86 F100/F150, FULL SIZE BRONCO STYLE	33 3/16"	2/4	5	LH	31
8.8"	MG2121	F5TZ4234B	2121L	1995-2000 EXPLORER/MOUNTAINEER STYLE	30 1/2"	2/4	5	LH	31
8.8"	MG2120	F5TZ4234D	2120R	1995-2000 EXPLORER/MOUNTAINEER STYLE	27 5/8"	2/4	5	RH	31
8.8"	E7TZ4234A	E7TZ4234A	1573R	1987-96 F150/BRONCO, 1987-98 E150 VAN STYLE	31 1/16"	2/4	5	RH	31
8.8"	E7TZ4234B	E7TZ4234B	1574L	1987-96 F150/BRONCO, 1987-98 E150 VAN STYLE	33 3/16"	2/4	5	LH	31
8.8"	E7UZ4234E	E7UZ4234E	1575L	1987-ON E150 VAN STYLE	35 5/8"	2	5	LH	31
8.8"	F7UZ4234BA	F7UZ4234BA	2439R	1997-2001 FORD® E150 VAN STYLE	31 1/16"	2	5	RH	31
8.8"	F7UZ4234BB	F7UZ4234BB	2440L	1997-2001 FORD® E150 VAN STYLE	35 5/8"	2	5	LH	31
8.8"	F87Z4234BA	F87Z4234BA	2417	1999-2001 RANGER STYLE	27 1/4"	2/4	5	RH	31
8.8"	F87Z4234BB	F87Z4234BB	2418	1999-2001 RANGER STYLE	30 1/4"	2/4	5	LH	31
8.8"	MG1575	E7UZ4234E	1575L	1987-98 E-150 VAN STYLE	35 5/8"	2	5	LH	31

LIGHT DUTY AXLE SHAFTS - REAR TRUCK

FORD® STYLE (CONT.)

MODEL # OR RING GEAR DIAM.	MOTIVE GEAR® PART #	CROSS REF. OEM PART #	CROSS REF. HOLLANDER® PART #	DESCRIPTION/STYLE	OVERALL LENGTH	2/4 WD	# OF LUGS	SIDE L/R	SPLINE COUNT
8.8"	MG1724	F1TZ4234A	1724R	1991-94 EXPLORER, NAVAJO STYLE	27 3/4"	2/4	5	RH	31
8.8"	MG1725	F1TZ4234B	1725L	1991-94 EXPLORER, NAVAJO STYLE	30 5/8"	2/4	5	LH	31
8.8"	MG2120	F5TZ4234A	2120R	1995-2000 EXPLORER 1997-PRESENT MOUNTAINEER STYLE	27 5/8"	2/4	5	RH	31
8.8"	MG2121	F5TZ4234B	2121L	1995-2000 EXPLORER 1997-PRESENT MOUNTAINEER STYLE	30 1/2"	2/4	5	LH	31
8.8"	MG2192	F75Z4234AA/NA	2192R	1997-ON F150 & EXPEDITION W/8.8" STYLE	31 3/4"	2/4	5	RH	31
8.8"	MG2193	F75Z4234AB/NB	2193L	1997-ON F150 & EXPEDITION W/8.8" STYLE	33 3/8"	2/4	5	LH	31
9"	D6TZ4234A	D6TZ4234A	2014	1974-86 FORD® 9", F150 & E150, BRONCO STYLE	31 27/32"	2/4	5	L/R	31
9"	MG3000	D3TZ4234F	1008L	1966-75 BRONCO SMALL BEARING STYLE	27 1/4"	4	5	LH	28
9"	MG3001	D3TZ4234G	1008R	1966-75 BRONCO SMALL BEARING STYLE	29 5/8"	4	5	RH	28
9"	MG3010	D3TZ4234J	1009L	1966-75 BRONCO LARGE BEARING - 3300 LB. STYLE	26 15/16"	4	5	LH	28
9"	MG3011	D3TZ4234K	1009R	1966-75 BRONCO LARGE BEARING - 3300 LB. STYLE	29 5/16"	4	5	RH	28
9"	MG3020	D4TZ4234F	1090L	1974-75 BRONCO LARGE BEARING - 2900 LB., W/10" BRAKE STYLE	27 1/4"	4	5	LH	28
9"	MG3021	D4TZ4234E	1090R	1974-75 BRONCO LARGE BEARING W/10" BRAKE STYLE	29 3/4"	4	5	RH	28
9"	MG3030	D6TZ4234G	1163L	1976-77 BRONCO LARGE BEARING STYLE	27 1/4"	4	5	LH	28
9"	MG3031	D6TZ4234F	1163R	1976-77 BRONCO LARGE BEARING STYLE	29 11/16"	4	5	RH	28
9.75"	F75Z4234LA	F75Z4234LA	2484R	1997-99 EXPEDITION, F150, NAVIGATOR STYLE	31 3/4"	2/4	5	RH	34
9.75"	F75Z4234LB	F75Z4234LB	2485L	1997-99 EXPEDITION, F150, NAVIGATOR STYLE	33 3/8"	2/4	5	LH	34
9.75"	F75Z4234MA	F75Z4234MA	2236R	1997-99 EXPEDITION, F150, NAVIGATOR STYLE	31 3/4"	2/4	5	RH	34
9.75"	F75Z4234MB	F75Z4234MB	2237L	1997-99 EXPEDITION, F150, NAVIGATOR STYLE	33 3/8"	2/4	5	LH	34
10.25"	E5TZ4234B	E5TZ4234B	1449R	1985 F250, SEMI-FLOAT STYLE	30 9/16"	2/4	8	RH	35
10.25"	E5TZ4234C	E5TZ4234C	1450L	1985 F250, SEMI-FLOAT STYLE	30 9/16"	2/4	8	RH	35
10.25"	MG1506	E6TZ4234B	1506R	1986-97 F250, SEMI-FLOAT STYLE	30 9/16"	2/4	8	RH	35
10.25"	MG1507	E6TZ4234C	1507	1986-97 F250, SEMI-FLOAT STYLE	33"	2/4	8	LH	35
D70	MG7401	C9TZ4234D		1963-74 FORD® F350 STYLE	35.42"	2/4	8	L/R	23
D70	MG7400	D5TZ4234A		1975-84 FORD® F350 STYLE	35.05"	2/4	8	L/R	35
D80	43651-1R	F0TZ4234A		1998 FORD® DANA® 80 STYLE	37.67"	2	8	L/R	37



LIGHT DUTY AXLE SHAFTS - REAR TRUCK

GMC® STYLE

RING GEAR DIAM.	MOTIVE GEAR® PART #	CROSS REF. OEM PART #	CROSS REF. HOLLANDER® PART #	DESCRIPTION/STYLE	OVERALL LENGTH	2/4 WD	# OF LUGS	SIDE L/R	SPLINE COUNT
7.5"	14030355	14030355	1310	1982-93 S10, S15, SM. BLAZER STYLE	26 9/16"	2	5	L/R	26
7.5"	26013882	26013882	1651	1988-97 S10, S15, SM. BLAZER, JIMMY, SONOMA STYLE	29"	4	5	L/R	28
7.5"	26015260	26015260	1861	1991-93 S10, S15, ABS BLAZER, JIMMY STYLE	29"	4	5	L/R	28
7.5"	26050549	26050549	2261	1998-2001 S10, S15, SM. BLAZER, JIMMY STYLE	28 13/16"	4	5	L/R	28
7.5"	26064388	26064388	2370	1998-2001 S10, S15 STYLE	26 5/8"	2	5	L/R	28
7.5"	MG1329	14035368	1329	1983-98 S10, S15, SM. BLAZER, JIMMY, SONOMA 1994-96 OLDS® BRAVADO STYLE	29"	4	5	L/R	26
7.5"	MG1408	14074821	1409L	1985-89 ASTRO VAN STYLE	34 3/4"	2	5	LH	26
7.5"	MG1764	26011055	1764R	1990-2001 ASTRO VAN STYLE	30 5/16"	2/4	5	RH	28
7.5"	MG1765	26011054	2173	1990-1998 ASTRO VAN STYLE	34 13/16"	2/4	5	LH	28
7.6"	12479210	12479210	2823L	2003-04 ASTRO VAN STYLE	35 1/2"	4	6	LH	28
7.6"	12479211	12479211	2822R	2003-04 ASTRO VAN STYLE	31"	4	6	RH	28
7.6"	26009534R	26009534	1599	1988-97 S-10 BLAZER STYLE	26 5/8"	2	5	L/R	28
7.6"	26014613	26014613		1990-ON RODEO GMC® STYLE	28 1/8"	2/4	6	L/R	28
8.0"	12479016	12479016	2646L	2002-04 TRAILBLAZER, ENVOY STYLE	33 3/8"	4	6	LH	28
8.0"	12479017	12479017	2645R	2002-04 TRAILBLAZER, ENVOY STYLE	31 1/2"	4	6	RH	28
8.5"	12479160	12479160	2653L	2002-05 ENVOY XL, TRAILBLAZER EXT STYLE	33 1/4"	4	6	LH	30
8.5"	12479161	12479161	2652R	2002-05 ENVOY XL, TRAILBLAZER EXT STYLE	31 3/4"	4	6	RH	30
8.5"	14035542	14035542	1204	1979-89 BLAZER, JIMMY, SUBURBAN, PICKUP, 1/2 TON, C10, C1500 STYLE	31 3/8"	2	5	L/R	28
8.5"	14039547	14039547	1300	1981-88 BLAZER, JIMMY, SUBURBAN, PICKUP, 1/2 TON STYLE	31 1/2"	4	6	L/R	28
8.5"	14042690	14042690	1085	1975-88 CHEVY® VAN 10 SER., 1979-88 CHEVY® VAN 20 SER., 1975-88 GMC® VAN 1500 SER., 1979-88 GMC® VAN 2500 SER. STYLE	33 5/16"	2	5	L/R	28
8.5"	15521892	15521892	1608	1988 CHEVY®/GMCv K1500 STYLE	33 1/8"	4	6	L/R	28
8.5/8.6"	26010414	26010414	1652	1988-91 BLAZER, JIMMY, SUBURBAN, PICKUP, 1/2 TON STYLE	31 1/2"	4	6	L/R	30
8.5/8.6"	26010415	26010415	1669	1988-91 SUBURBAN, 1/2 TON 1988-91 CHEVY® BLAZER STYLE	31 3/8"	2	5	L/R	30
8.5/8.6"	26010416	26010416	1671	1988-2000 GMC® PICKUP, 1/2 TON STYLE 1992-98 SUBURBAN, TAHOE-YUKON STYLE	33"	2/4	6	L/R	30
8.5/8.6"	26010417	26010417	1670	1988-2000 PICKUP, 1/2 TON, 1992-98 SUBURBAN 1500 SERIES, TAHOE 1988-98 CHEVY®/GMCv TRUCK 1500 SER., 1994-98 CHEVY® YUKON STYLE	31 13/16"	2	5	L/R	30
8.5"	26013313	26013313	1672	1988-95 CHEVY®/GMC® VAN, 1/2 TON STYLE	33 5/16"	2	5	L/R	30
8.5"	26033364	26033364	2056	1994-97 S10, S15, SM. BLAZER NON-ZR2 STYLE	28 13/16"	4	5	L/R	30
8.5"	26042818	26042818	2172	1996-2001 CHEVY®/GMC® G1500 VAN STYLE	33 1/4"	2	5	L/R	30
8.5"	26058079	26058079	2414	1998-2001 S10, S15, SM. BLAZER NON-ZR2 STYLE	28 13/16"	4	5	L/R	30
8.6"	12471369	12471369	2457	1999-2001 SILVERADO/SIERRA, 1/2 TON DISC STYLE	33 9/16"	2/4	6	L/R	30

LIGHT DUTY AXLE SHAFTS - REAR TRUCK

GMC® STYLE (CONT.)

RING GEAR DIAM.	MOTIVE GEAR® PART #	CROSS REF. OEM PART #	CROSS REF. HOLLANDER® PART #	DESCRIPTION/STYLE	OVERALL LENGTH	2/4 WD	# OF LUGS	SIDE L/R	SPLINE COUNT
8.6"	12479285	12479285		1999-ON SILVERADO, SIERRA 1/2 TON WORKS W/ OR W/O ACTIVE BRAKE CONTROL STYLE	33 9/16"	2/4	6	L/R	30
8.6"	26058925	26058925	2498	1998-2003 S10, BLAZER, JIMMY STYLE	26 3/8"	2	5	L/R	30
8.6"	40009129	40009129	2756	2003-05 CHEVY® 1500 VAN STYLE	34 1/2"	2/4	5	L/R	30
8.6"	40016171	40016171	2755	2003-05 ESCALADE, TAHOE, YUKON W/ ACTIVE BRAKE CONTROL STYLE	33 9/16"	2/4	6	L/R	30
8.875"	14071750	14071750	1063	1970-81 BLAZER, JIMMY, SUBURBAN, PICKUP, 1/2 TON STYLE	31 9/32"	4	6	L/R	30
8.875"	14071751	14071751	1062	1971-81 BLAZER, SUBURBAN, PICKUP STYLE	31 5/16"	2/4	5	L/R	30
8.875"	3893605	3893605	780	1965-69 CHEVY®/GMC® 1/2 TON PICKUP STYLE	30 11/16"	2/4	6	L/R	30
8.875"	MG6569			1965-69 GMCv STYLE	30 1/2"	2/4	6/5		
9.5"	14035355	14035355	1347L	1983-96 CHEVY®/GMC® 1 TON VAN, SINGLE WHEEL STYLE	35 7/8"	2	8	LH	33
9.5"	15521928	15521928	1610	1988-99 PICKUP, SUBURBAN, 1/2 TON & 3/4 TON STYLE	33 1/8"	4	6	L/R	33
9.5"	15522068	15522068	1609	1988-98 CHEVY® 3/4 TON, SEMI-FLOAT STYLE	31 9/16"	2	6	L/R	33
9.5"	26060414	26060414	2458	1999-2001 SILVERADO/SIERRA 3/4 TON DISC STYLE	33 5/16"	2/4	8	L/R	33
9.5"	40014728	40014728	2753	2003-05 HUMMER® H2 STYLE	34 5/8"	4	8	L/R	33
9.5"	MG1276	14035395	1276	1981-96 CHEVY®/GMC® 3/4 TON & 1 TON - INCLUDING VAN & SUBURBAN STYLE	32 31/2"	2/4	8	L/R	33
9.5"	MG1615	15522070	1615	1988-99 PICKUP, SUBURBAN, 3/4 TON 1989-98 CHEVY®/GMC® TRUCK 2500 SER. 1988-89 CHEVY®/GMC® TRUCK 3500 SER. 1992-98 SUBURBAN 1500 SER. W/8 HOLES 1992-98 SUBURBAN 2500 SER. STYLE	31 13/16"	2/4	8	L/R	33
10.5"	12471329	12471329	2594	1999-2001 SILVERADO/SIERRA 3/4 TON - DISC STYLE	39"	2/4	8	RH	30
10.5"	26020039	26020039	1975	1992-2000 CHEVY®/GMC® 1 TON PICKUP - SINGLE WHEEL STYLE	32 3/4"	2/4	8	LH	30
10.5"	26020040	26020040	1974	1996-2001 CHEVY® 1 TON PICKUP - SINGLE WHEEL & 1996-01 CHEVY® 1 TON VAN DUALY STYLE	37"	2/4	8	P/U-RH VAN-LH	30
10.5"	26042925	26042925	2283	1996-01 CHEVY®/GMC® VAN, SINGLE WHEEL STYLE	39 3/16"	2	8	RH	30
10.5"	26042927	26042927	2372	1996-2001 CHEVY® 1 TON VAN DUALY STYLE	42 1/4"	2	8	RH	30
10.5"	26045426	26045426	2284	1996-01 CHEVY®/GMC® VAN, SINGLE WHEEL STYLE	33 3/8"	2/4	8	LH	30
10.5"	MG1774	3977384	1774R	1973-93 CHEVY®/GMC® 3/4 TON & 1 TON - FULL FLOAT STYLE	37 9/16"	2/4	8	RH	30
10.5"	MG1775	3977383	1775L	1973-2000 CHEVY®/GMC® 3/4 TON & 1 TON FULL FLOAT STYLE	31 11/16"	2/4	8	LH	30
11.5"	40003201	40003201	2595	2001-04 SILVERADO/SIERRA, 3/4 TON & 1 TON SINGLE WHEEL STYLE	35 15/16"	2/4	8	L/R	30
11.5"	40003202	40003202	2593	2001-04 SILVERADO/SIERRA, 1 TON - DUALY WIDE TRACK STYLE	40 1/8"	2/4	8	L/R	30
11.5"	40003204	40003204	2596	2001-04 SILVERADO/SIERRA 1 TON DUALY NARROW TRACK STYLE	36 1/8"	2/4	8	L/R	30
D70	41100-1R	41100-1		1994-97 GMC® STYLE	39.69"	2	8	L/R	35

LIGHT DUTY AXLE SHAFTS - REAR TRUCK

GMC® STYLE (CONT.)

RING GEAR DIAM.	MOTIVE GEAR® PART #	CROSS REF. OEM PART #	CROSS REF. HOLLANDER® PART #	DESCRIPTION/STYLE	OVERALL LENGTH	2/4 WD	# OF LUGS	SIDE L/R	SPLINE COUNT
D70HD	MG7505	36453-2		1973-79 C10-C30 STYLE	34.39"	2	8	L/R	35
D80	44264-1R	44264-1		1992-2000 GMC® DANA® 80 STYLE	36.17"	2	8	L/R	37

Motive

**TRAIL TESTED...
DRIVER APPROVED**

Off road competitors turn to **Motive Gear** ring & pinions for:

- ▶ Core Strength
- ▶ Reliability
- ▶ Easy Installation
- ▶ Comprehensive Warranty

Motive Gear®

SPOOLS
PINION YOKES
CASES
INTERNAL KITS



Differential Components

MINI SPOOLS & FULL SPOOLS

MINI SPOOLS

CHRYSLER® STYLE

PART #	DESCRIPTION
MSD44-30	8.75" 30 SPLINE

FORD® STYLE

MS88-28	8.8" 28 SPLINE - STEEL
MS88-31	8.8" 31 SPLINE - STEEL
MS9-28*	8" & 9" 28 SPLINE - STEEL
MS9-28-4*	8" & 9" 28 SPLINE - STEEL - 4 PINION
MS9-31*	9" 31 SPLINE - STEEL
MS9-31-4*	9" 31 SPLINE - STEEL - 4 PINION

* LIGHT WEIGHT

GM® STYLE

MS7.5-26	7.5" 26 SPLINE - STEEL
MS7.5-28	7.5" 28 SPLINE - STEEL
MS10-28	8.5" 10 BOLT 28 SPLINE - STEEL
MS10C-28	8.2" 10 BOLT 28 SPLINE - STEEL
MS12C	8.875" 12 BOLT 30 SPLINE - STEEL

FULL SPOOLS

CHRYSLER® STYLE

PART #	DESCRIPTION
FS8.75-30	8.75" 30 SPLINE - STEEL

DANA® STYLE

FSD44-30	8.75" 35 SPLINE - STEEL
FSD60-35H	9.75" 35 SPLINE
FSD60-35L	9.75" 35 SPLINE

FORD® STYLE

FS8.8-31	8.8" 31 SPLINE - STEEL
FS9-28	9" 28 SPLINE - STEEL
FS9-28LW	9" 28 SPLINE - LIGHT WEIGHT
FS9-31*	9" 31 SPLINE - STEEL
FS9-31LW	9" 31 SPLINE - LIGHT WEIGHT
FS9-33*	9" 33 SPLINE - STEEL
FS9-35**	9" 35 SPLINE - STEEL
FS9-40**	9" 40 SPLINE - STEEL

* USE 3.062 BORE HOUSING

** USE 3.250 BORE HOUSING

GM® STYLE

FS10-28	8.5" 10 BOLT 28 SPLINE - STEEL
FS10-30	8.5" 10 BOLT 30 SPLINE - STEEL
FS12-30	8.78 12 BOLT 30 SPLINE - STEEL - CAR ONLY

NODULAR HOUSINGS & PINION SUPPORTS

NODULAR HOUSINGS

PART#	DESCRIPTION
26304	9" W/ 3.062 BORE DIAMETER - STEEL STREET CASE
26305	9" W/ 3.25 BORE DIAMETER - STEEL STREET CASE
26306	9" W/ 3.062 BORE DIAMETER - STEEL
26306A	9" W/ 3.062 BORE DIAMETER - ALUMINUM
26325	9" W/ 3.25 BORE DIAMETER - STEEL
26325A	9" W/ 3.25 BORE DIAMETER - ALUMINUM

PINION SUPPORTS

PART#	DESCRIPTION
25100	9" PINION SUPPORT - ALUMINUM
25105	9" PINION SUPPORT KIT W/BEARINGS & SEALS - ALUMINUM
225200	9" PINION SUPPORT DAYTONA - STEEL
25200A	9" PINION SUPPORT DAYTONA - ALUMINUM
M4614A	9" PINION SUPPORT DAYTONA - ALUMINUM
M4614B	9" PINION SUPPORT DAYTONA - STEEL



**Motive
Gear®**

PINION YOKES & ASSOCIATED COMPONENTS

PINION YOKES

AXLE ID STYLE	OA LENGTH	SERIES	ITEM #	MATERIAL	SPLINE	U-JOINT	U-BOLT/ STRAP
AMC® 20 STYLE							
8.875	2.938	1310	MG1310-2027	CAST	28	5-153XR	STRAP
8.875	2.938	1330	2-4-7031-1X	CAST	28	5-213XR	STRAP
8.875		1350	MG1350-2028	CAST	28	5-178XR	STRAP
CHRYSLER® STYLE							
7.25,8.25	2.750	7260	MG7260-7227	CAST	27	5-1306X	STRAP
7.25,8.25	2.750	7290	MG7290-8258	CAST	27	5-1309X	STRAP
8.25		7290	MG1330-8253	CAST	28	5-737X	STRAP
8.75	3.340	1350	MG1350-8751	ALUMINUM BILLET	10	5-178XR	STRAP
8.75	3.140	1350	MG1350-8755	CAST	10	5-178XR	STRAP
8.75	3.098	1350	MG1350-8775	FORGED	10	5-178XR	STRAP
8.75	3.350	1350 PRO	MG1350-C875*	CHROMOLY BILLET	10	5-447X	UB
8.75	3.350	7260	MG7260-8705	CHROMOLY BILLET	10	5-1306X	UB
8.75	3.350	7260	MG7260-8706	ALUMINUM BILLET	10	5-1306X	STRAP
8.75	3.350	7290	MG7290-8711	ALUMINUM BILLET	10	5-1309X	STRAP
8.75 MOPAR®	3.350	7260	MG7260-8751	CAST- OEM	10	5-1306X	STRAP
MUSCLE CAR RESTORATION							
8.75 MOPAR®	3.350	7290	MG7290-8752	CAST-OEM	10	5-1309X	STRAP
MUSCLE CAR RESTORATION							
8.75	3.350	4130	MG7290-8710	CHROMOLY BILLET	10	5-1309X	UB
8.75, 9.25	3.000	1350	MG1350-C87529*	CAST RACING ONLY	29	5-447X	UB
8.75, 9.25	3.000	1350	MG1350-8759	CHROMOLY BILLET HP	29	5-178XR	UB
8.75, 9.25	3.350	7260	MG7260-C875*	CAST	29	5-1306X	STRAP
8.75, 9.25	3.350	7260	MG7260-8762*	CHROMOLY BILLET	29	5-1306X	UB
8.75, 9.25	3.188	7290	MG7290-C875*	CAST	29	5-1309X	STRAP
8.75, 9.25	3.350	7290	MG7290-8760*	CHROMOLY BILLET HP	29	5-1309X	UB
* 30 DEGREE PRESSURE ANGLE OF TOOTH							
DANA® STYLE							
28 FORD®	3.00	1310	MG1310-D2823S	CAST	23	5-153XR	STRAP
RANGER							
35	2.938	1310	MG1310-3526	CAST	26	5-153XR	STRAP
35	3.562	1330	MG1330-3527	CAST	26	5-213XR	STRAP
44	3.00	1310	MG1310-D4410S	CAST	10	5-153XR	STRAP
44 ICA GM®, JEEP®	2.930	1310	MG1310-3801	CAST XHD	29	5-153XR	STRAP
44 R JEEP®, R GM®	3.000	1310	MG1310-D4426U	CAST	26	5-153XR	UB
F CAR & ICA							
44 ICA GM®, JEEP®	2.995	1310	MG1310-6015	BILLET	29	5-153XR	UB
44 ICA GM®, JEEP®	2.970	1310	MG1310-6010*	CAST	29	5-153XR	UB
44 R JEEP®	3.000	1310	MG1310-6561	CAST	26	5-153XR	STRAP
44 R JEEP®	3.000	1310	MG1310-6781	CAST	26	5-153XR	STRAP
44 R JEEP®	3.250	1310	MG1310-7301	CAST	26	5-153XR	STRAP
44HD, 60, 70 F&R	2.938	1310	MG1310-6020	CAST XHD	29	5-153XR	STRAP
DODGE®, FORD®, F-GM®, R-JEEP®							
44 R GM®	3.000	1330	MG1330-D4426S	CAST	26	5-213XR	STRAP
44, 60 R JEEP®	2.930	1330	MG1310-D4426S	CAST	26	5-153XR	STRAP

PINION YOKES & ASSOCIATED COMPONENTS

AXLE ID STYLE	OA LENGTH	SERIES	ITEM #	MATERIAL	SPLINE	U-JOINT	U-BOLT/ STRAP
DANA® STYLE CONT.							
44 F&R FORD®	3.000	1330	MG1330-D4426U	CAST	26	5-213XR	UB
44HD, 60, 70	2.938	1330	MG1330-6040*	CAST XHD	29	5-213XR	STRAP
44ICA	3.188	1330	MG1330-4450	CAST	26	5-213XR	STRAP
44ICA	3.188	1350	MG1350-4451	CAST	26	5-178XR	STRAP
44	3.00	1350	MG1350-D4426S	CAST	26	5-178XR	STRAP
44 ICA VIPER	3.000	1350	(NLA)	CAST	29	5-178XR	STRAP
44 ICA VIPER	3.000	1350	MG1350-6055**	BILLET HP	29	5-178XR	UB
44 ICA VIPER	3.000	1350	MG1350-6000#	CAST	29	5-178XR	UB
#REPLACES DISCONTINUED DANA® #3-4-5731X STYLE							
44HD, 60, 70		1350	MG1350-6050	CAST	29	5-178XR	STRAP
44 R JEEP®	3.219	7290	2-4-8311-1	CAST	26	5-1309X	STRAP
44 F DODGE®	3.350	7290	2-4-7651-1X	CAST	26	5-1309X	STRAP
**20 DEGREE PRESSURE ANGLE OF TOOTH				*45 DEGREE PRESSURE ANGLE OF TOOTH			
D60	2.970	1310	MG1310-6010*	CAST XHD	29	5-153XR	UB
60 F FORD®, GM®	2.970	1310	MG1310-6020*	CAST XHD	29	5-153XR	STRAP
R FORD®, JEEP®							
60	2.995	1310	MG1310-6015*	BILLET HP XHD	29	5-153XR	UB
60	3.180	1330	MG1330-6030*	CAST XHD	29	5-213XR	UB
60, 61, 70 F & R	2.938	1330	MG1330-6030*	FORGED	29	5-213XR	UB
FORD®							
60, 61, 70	2.938	1330	2-4-8051-1X*	CAST XHD	29	5-213XR	STRAP
F&R FORD®							
60, 70 F&R FORD®	3.000	1350	MG1350-6000*	CAST XHD	29	5-178XR	UB
60	3.000	1350	MG1350-6055*	BILLET HP XHD	29	5-447X	UB
60, 70	3.330	1350	MG1350-6057*	BILLET HIGH ANGLE XHD	29	5-178XR	BILLET CAP
60,70		1350	MG1350-6075	FORGED	29	5-178XR	STRAP
70 R DODGE®	3.000	1410	MG1410-6050*#	FORGED XHD	29	5-160XR	UB
#REPLACES DISCONTINUED DANA #3-4-5711X							
60, 70 R DODGE®	3.188	1410	MG1410-6095	CAST XHD	29	5-160XR	STRAP
80 R DODGE®	4.312	1410	3-4-11081-1X*	CAST	37	5-160XR	STRAP
80 DODGE®	4.300	1410	(NLA)	CAST	37	5-160XR	STRAP
80	4.328	1480	MG1480-D8035	CAST	35	5-188XR	STRAP
60, 70	3.010	7260	MG7260-9755*	BILLET XHD	29	5-1306X	UB
60, 70 HD HEMI	3.340	7290	MG7290-9757*	CHROMOLY BILLET XHD	29	5-1309X	UB
60, 70, F&R	3.340	7290	MG7290-9756*	CAST XHD	29	5-1309X	STRAP
DODGE® OEM							
HEMI							
60, 70 F&R	3.359	7290	2-4-7681-1X*	CAST XHD	29	5-1309X	STRAP
DODGE®							
**20 DEGREE PRESSURE ANGLE OF TOOTH				*45 DEGREE PRESSURE ANGLE OF TOOTH			
FORD® STYLE							
8.8	1.470	1330	MGCF1330-8027	CAST	30	5-213XR	STRAP
8.8	3.200	1330	MG1330-8810	CAST	30	5-1204XR	STRAP
8.8	3.200	1350	MG1350-F88	4340 CHROMOLY BILLET	30	5-447X	UB
8.8	2.868	1350	MG1350-8875	FORGED	30	5-178XR	STRAP
9	4.080	1310	MG1310-9000	CAST W FLINGER	28	5-153XR	UB
9	3.810	1330	MG1330-9015	ALUMINUM BILLET	28	5-213XR	UB
9		1310	MG1310-9254	CAST (MACHINED FOR DAYTONA PINION SUPPORT)		5-153XR	UB
9	3.870	1310	MG1310-9285	CHROMOLY BILLET	28	5-153XR	UB
9	3.870	1310	MG1310-9286	ALUMINUM BILLET	28	5-153XR	UB

PINION YOKES & ASSOCIATED COMPONENTS

AXLE ID STYLE	OA LENGTH	SERIES	ITEM #	MATERIAL	SPLINE	U-JOINT	U-BOLT/ STRAP
9	4.070	1330	MG1330-9010	CAST	28	5-213XR	UB
9	4.070	1330	MG1330-9044	CAST	28	5-213XR	UB
9	3.810	1330	MG1330-9046	CAST DAYTONA	28	5-1204XR	UB
9	5.075	1330	MG1330-9050	CAST	28	5-1204XR	STRAP
9	4.120	1350	MG1350-F9280	4340 CHROMOLY BILLET W/ FLINGER	28	5-178XR	UB
9	4.120	1350	MG1350-F928	4340 CHROMOLY BILLET DRAG RACE W/ DCRL	28	5-178XR	UB
9	4.120	1350	MG1350-F928A	ALUMINUM /FLINGER	28	5-178XR	UB
9	3.845	1350	MG1350-F935	BILLET PRO DRAG RACE	35	5-178XR	UB
9	4.045	1350	MG1350-F9282	FORGED W PULLEY	28	5-178XR	UB
9	4.100	1350	MG1350-9275	FORGED	35	5-178XR	STRAP
9	3.598	1350	MG1350-9375	FORGED	28	5-178XR	STRAP
10.25 83-93 W/1.265" SPL	3.150	1330	MG1330-F1025E	CAST	31	5-1204XR	STRAP
10.25 94-ON W/1.640" SPL	3.550	1330	MG1330-F1025L	CAST	31	5-1204XR	UB
10.25 83-93 W/1.265" SPL	3.150	1350	MG1350-F1025E	CAST	31	5-178XR	STRAP
10.25 94-ON W/1.640" SPL	3.550	1350	MG1350-F1025L	CAST	31	5-178XR	STRAP
GMC® STYLE							
7.25IFS	3.185	1310	MG1310-7250	CAST	27	5-153XR	STRAP
7.25IFS	3.570	3R/1344	MG3R-7251	CAST	27	5-3147XR	STRAP
10 BOLT 7.5, 7.6	3.500	1310	MG1310-7501	CAST	27	5-153XR	STRAP
10 BOLT 7.5, 7.6	3.175	1310	MG1310-7505	CAST	27	5-153XR	STRAP
10 BOLT 7.5, 7.6	3.250	1350	MG1350-7555	CAST	27	5-447X	STRAP
7.5, 7.6	3.55	3RS44	MG3R-7500	CAST	27	5-3147XR	STRAP
7.5, 7.6	3.585	3RS44	MG3R-7566	CAST	27	5-3147XR	STRAP
7.6	3.565	3RS44	MG3R-7560	CAST	27	5-3147XR	STRAP
7.6, 8.0		3R/1344	MG3R-8000	CAST	27	5-3147XR	STRAP
10 BOLT 8.20 55-64 CAR	2.620	1310	MG1310-8250	FORGED	17	5-153XR	UB
8.25IFS, 9.25IFS	3.400	3R/1344	MG3R-8255	CAST	30	5-3147XR	STRAP
10 BOLT 64-72 CAR	2.900	1310	MG1310-8200	FORGED	25	5-153XR	UB
10 BOLT 8.5	2.778	1350	MG1350-8575	FORGED	28	5-178XR	STRAP
10 BOLT 8.5, 8.6 14 BOLT 9.5	3.250	1310	MG1310-8505	CAST	30	5-153XR	STRAP
10 BOLT 8.5 14 BOLT 9.5	3.200	1350	MG1350-8550	CHROMOLY BILLET	30	5-178XR	UB
10 BOLT 8.5 14 BOLT 9.5	3.125	1350	MG1350-8515	CAST	30	5-178XR	STRAP
10 BOLT 8.5 14 BOLT 9.5	3.400	3RS44	MG3R-8500	STOCK CAST	30	5-3147XR	STRAP
10 BOLT 8.5 14 BOLT 9.5	3.400	3RS44	MG3R-8554	BILLET REPLACEMENT	30	5-3147XR	UB
10 BOLT 8.6 14 BOLT 9.5	3.400	3RS44	MG3R-8555	CAST	30	5-3147XR	STRAP
12 BOLT 8.875	2.650	1310	MG1310-1200	CAST	30	5-153XR	UB
12 BOLT 8.875	2.870	1310	MG1310-1210	CAST	30	5-153XR	STRAP
12 BOLT 8.875	2.650	1310	MG1310-1255	CHROMOLY BILLET	30	5-153XR	UB
12 BOLT 8.875	2.650	1310	MG1310-1256	BILLET ALUMINUM	30	5-153XR	UB
12 BOLT 8.875	2.75	1330	MG1330-1220	FORGED	30	5-213XR	STRAP

PINION YOKES & ASSOCIATED COMPONENTS

AXLE ID STYLE	OA LENGTH	SERIES	ITEM #	MATERIAL	SPLINE	U-JOINT	U-BOLT/ STRAP
12 BOLT 8.875	2.750	1330	MG1330-1222	CAST	30	5-213XR	UB
12 BOLT 8.875	3.250	1350	MG1350-GM12	BILLET HP W FLINGER DRAG RACE W/DCRL	30	5-178XR	UB
12 BOLT 8.875	3.250	1350	MG1350-1202	4340 BILLET	30	5-178XR	UB
12 BOLT 8.875	3.250	1350	MG1350-1203	7075 BILLET ALUMINUM DRAG RACE W/DCRL	30	5-178XR	UB
12 BOLT 8.875	3.18	1350	MG1350-1250	FORGED	30	5-178XR	STRAP
12 BOLT 8.875		1350	MG1350-1275	FORGED	30	5-178XR	UB
12 BOLT 8.875	2.720	3RS44	MG3R-1275	BILLET HP	30	5-3147XR	UB
12 BOLT 9.25IFS	2.778	3R/1344	MG3R-8255	CAST	30	5-3147XR	STRAP
12 BOLT 9.25IFS	3.400	3RS44	MG3R-9251	CAST	30	5-178XR	STRAP
14 BOLT 9.5	3.400	1350	MG1350-8520	CAST	30	5-178XR	STRAP
14 BOLT 9.50 EL	3.350	1350	MG1350-9510	CAST	30	5-178XR	STRAP
14 BOLT 10.5	3.719	1350	MG1350-1050	CAST	30	5-447X	STRAP
EARLY TO 98							
14 BOLT 10.5	3.719	1350	MG1350-1051	CAST	30	5-447X	STRAP
LATE 99-ON							
14 BOLT 10.5	3.956	1410	MG1410-1055	CAST	30	5-160XR	STRAP
EARLY TO 98							
14 BOLT 10.5	3.956	1410	MG1410-1056	CAST	30	5-160XR	STRAP
LATE 99-ON							
14 BOLT 11.5	3.900	1410	MG1410-1150	CAST	30	5-160XR	STRAP
14 BOLT 11.5	3.900	1480	MG1480-1151	CAST	30	5-188XR	STRAP
W/DCRL= WITH DATA COLLECTION RING LAND							
QUICK CHANGE		1310	MG1310-2611	FORGED	10	5-153XR	UB
QUICK CHANGE		1350	MG1350-1010	FORGED	10	5-178XR	STRAP

SMALL PARTS

U-BOLTS AND BOLT & STRAP ASSEMBLY

SERIES	U-BOLTS CAST	U-BOLTS CHROMOLY	BOLT & STRAP ASSEMBLY	BILLET CAP OPTION (HD-APPLICATIONS)
1210	2-94-28X		2-70-18X	AS OEM BOLT & STRAP REPLACEMENT
1310	2-94-28X		2-70-18X	
1310	MGUB1310XL			
1330	2-94-28X		2-70-18X	
1330 SPECIAL	2-94-58X		2-70-28X	
1350	3-94-18X	MGUB1350*	3-70-28X	BK1350HD
1410	3-94-18X	MGUB1350*	3-70-28X	BK1350HD
3R/S44	MGUB3R*		2-70-48X	
7260	2-94-58X		2-70-38X	
7290			SK7290	

*KITS INCLUDE CHROMOLY U-BOLTS WHICH ARE LONGER THAN DANA® AND GRADE 8 BOLTS

PINION YOKE MICRO SLEEVES

MODEL AXLE STYLE	OD	PART#
CHRYSLER® 8.75, DANA® 60	1.875	MGMS426-1875
UP TO '99 GM® 8.5, 9.5, 67-70 BOP	1.940	MGMS454-1940
FORD® 8" 8.89, 9.75	1.805	MGMS427-1805
ALL-INSTALLATION TOOL		MS-TOOL

1350 SPICER® STYLE U-JOINTS AVAILABLE IN 3 TYPES

5-178XR STD LUBE
5-799X SOLID
5-447X SOLID RACE-BEST FOR HIGH HORSE POWER/DRAG RACE APPLICATIONS

CASES & INTERNAL PARTS KITS

THIS IS A BASIC GUIDE TO CASES AND INTERNAL PARTS KITS CONSOLIDATING INFORMATION FROM MANY SOURCES. IT IS NOT COMPLETE AS WE HAVE OMITTED PARTS WHICH ARE OBSOLETE OR ARE AVAILABLE FROM A DEALER ONLY, AND REFERS TO MODELS BETWEEN 1978 AND 2002 IN MOST CASES. WITH DANA® STYLE AXLES, IT IS ALWAYS BEST TO USE THE VEHICLE BILL OF MATERIAL NUMBER AND CALL FOR CORRECT PART NUMBERS. IF YOU HAVE A FORD® STYLE TAG # WE CAN USE THESE AS WELL. CALL YOUR SALES REPRESENTATIVE WITH YEAR, MAKE, MODEL TAG AND BM#. WE WILL BE HAPPY TO HELP YOU. FOR INFORMATION ON AFTERMARKET CASE ALTERNATIVES SUCH AS ARB®, AUBURN® & EATON® PERFORMANCE STYLES, INCLUDING TRUETRAC® & DETROIT LOCKERS®, PLEASE USE THOSE SECTIONS OF THIS CATALOG.

DODGE®/ CHRYSLER® STYLE - FRONT

YEAR	DESCRIPTION	TYPE/RATIO	CASE ASSEMBLY KIT	CASE KIT	INTERNAL KIT	DIA/SPL
MODEL C9.25IFS STYLE						
03-ON	RAM	STD EMPTY ALL	05086691AA	14012695	GM9.5BI	1.37/33
MODEL D44 STYLE						
79-89	W100-W200	STD 3.54-UP	706020X	706024X	706027X	1.31/30
79-89	W100-W200	STD 3.92-DN	706021X	706025X	706027X	1.31/30
85-93.5	D500-D800	STD 3.54-UP	707021X	707023X	707025X	1.31/30
94-01	RAM	STD 3.54-UP	707021-1X	707024X	707025-1 (NLA)	1.31/30
94-01	RAM	STD 3.92-UP	707022-1X	706025X	707025-1 (NLA)	1.31/30
MODEL D60 STYLE						
79-93	D600-D700	STD 4.10-DN	706180X	706040X	706181-1 (NLA)	1.50/35
MODEL D60HD STYLE						
95-99.5	D3500 W2500 W3500	STD 4.10-DN	707339-1X	706040X	707340-1X	1.31/30
00-01.5	D3500 W2500 W3500	STD 4.10-DN	708048	706040X	708049	1.37/32
MODEL D61 STYLE						
87-93.5	D600-D700	STD 4.10-DN	706180X	706040X	706181X	1.50/35

DODGE®/ CHRYSLER® STYLE - REAR

YEAR	DESCRIPTION	TYPE/RATIO	CASE ASSEMBLY KIT	CASE KIT	INTERNAL KIT	DIA/SPL
MODEL C7.25" STYLE						
63-97		STD EMPTY ALL	NA	C7.25E	C7.25BI	1.15/25
MODEL C8.25" STYLE						
66-97		STD EMPTY ALL	NA	C8.25E	C8.25BI	1.17/27
97-ON		STD	NA	NA	C8.25BIL	1.21/29
97-ON		T/L ASSY ALL	NA	C8.25-TLCA	NA	1.21/29
MODEL C9.25" STYLE						
68-ON		STD EMPTY ALL	NA	C9.25E	C9.25BI	1.32/31
68-ON		T/L ASSY ALL	NA	C9.25-TLCA	NA	1.32/31
MODEL C10.5" STYLE						
03-ON	DODGE® RAM	STD ALL	C10.5L	C10.5E	NA	1.50/30
03-ON	DODGE® RAM	TRACRITE® GT LKR ALL	C10.5LKR	NA	NA	1.50/30

CASES & INTERNAL PARTS KITS

DODGE® / CHRYSLER® - REAR (CONT.)

YEAR	DESCRIPTION	TYPE/RATIO	CASE ASSEMBLY KIT	CASE KIT	INTERNAL KIT	DIA/SPL
MODEL C11.5" STYLE						
03-ON	RAM	STD EMPTY ALL	NA	C11.5E	C11.5BI	1.50/30
03-ON	DUAL WHEEL RAM	TRACRITE® OPEN ASSY	C11.5L	NA	NA	1.50/30
03-ON	DUAL WHEEL RAM	TRACRITE® GT (LKR)	C11.5LKR	NA	NA	1.50/30
MODEL D44ICA STYLE						
98-00	VIPER REAR	T/L 3.07-3.73	75499X	41232	NA	1.31/30
00.5	VIPER REAR	T/L 3.07-4.10	80740	50734 (NLA)	NA	1.31/30
MODEL D60 STYLE						
79-01	VARIOUS MODELS REAR AS FOLLOWS: B300B600,C300,D200,D300,D800MB300DRW HD, W200HD					
78-89		STD 4.10-DN	706036X	706040X	706043X	1.31/30
78-89		STD 4.56-UP	706037X	706041X	706043X	1.31/30
79-01		T/L 4.10-DN	708013	708014	707084X	1.31/30
79-01		STD 4.10-DN	708010	708011	706043X	1.31/30
94-01	RAM	T/L 4.10-DN	708013	708014	707084X	1.31/30
94-01	RAM	STD 4.10-DN	708010	708011	706043X	1.31/30
79-98	HP RACING APPS	STD 4.56-UP	706182X	706041X	706181X	1.50/35
MODEL D70 STYLE						
79-93.5	VARIOUS MODELS REAR AS FOLLOWS: CB300HD, CB400, D300, D400,D500,D600,D700,M300, M400, MB400, M500, W350, WM300					
MODEL D70B STYLE						
79-85.5	W/ 1/2" OFFSET	STD 4.10-DN	706051X	706055X	706058X	1.50/35
79-85.5	W/ 1/2" OFFSET	STD 4.56-UP	706052X	706056X	706058X	1.50/35
79-85.5	W/ 1/2" OFFSET	P/L 4.10-DN	706049X	706053X	706057X	1.50/35
79-85.5	W/ 1/2" OFFSET	P/L 4.56-UP	706050X	706054X	706057X	1.50/35
MODEL D70-2U STYLE						
89-91	W/ ANTILOCK	STD 4.10-DN	707128X	708017	706058X	1.50/35
89-91	W/ ANTILOCK	STD 4.56-UP	707124X	708023	706058X	1.50/35
89-91	W/ ANTILOCK	P/L 4.10-DN	707130X	708019	707074X	1.50/35
89-91	W/ ANTILOCK	P/L 4.56-UP	707126X	708025	707074X	1.50/35
91-01	W/ ANTILOCK	STD 4.10-DN	708016	708017	707254X	1.37/32
91-01	W/ ANTILOCK	STD 4.56-UP	708022	708023	707252X	1.37/32
91-01	W/ ANTILOCK	P/L 4.10-DN	708018	708019	707254X	1.37/32
91-01	W/ ANTILOCK	P/L 4.56-UP	708024	708025	707254X	1.37/32
MODEL D70HD STYLE						
78-83	W/5/8" OFFSET	STD 4.10-DN	706064X	706068X	706058X	1.50/35
78-83	W/5/8" OFFSET	STD 4.56-UP	706065X	706069X	706058X	1.50/35
MODEL D80 STYLE						
94-01	D/W2500, D3500 REAR	STD 3.73-DN	708027	708028	707063X	1.50/35
94-01	D/W2500, D3500 REAR	STD 4.10-UP	708031	708032	707063X	1.50/35
94-01	D/W2500, D3500 REAR	T/L 3.73-DN	708054	708055 (NLA)	708051	1.50/35
94-01	D/W2500, D3500 REAR	T/L 4.10-UP	708052	708053	708051	1.50/35

CASES & INTERNAL PARTS KITS

FORD® STYLE - FRONT

YEAR	DESCRIPTION	TYPE/RATIO	CASE ASSEMBLY KIT	CASE KIT	INTERNAL KIT	DIA/SPL
MODEL D28IFS STYLE						
83-89	RANGER	STD 3.54-UP	706974X	706975X	706890X	1.00/23
84-89	BRONCO II	STD 3.54-UP	706974X	706975X	706890X	1.00/23
93-94.5	RANGER	STD 3.54-UP	707270X	707272X (NLA)	706890X	1.00/23
95-97.5	RANGER W/ ABS	STD 3.54-UP	707270X	707272X (NLA)	706890X	1.00/23
97	RANGER NON-ABS	STD 3.54-UP	707270X	707272X (NLA)	706890X	1.00/23
MODEL D35IFS STYLE W/ CARDAN JOINT FRONT AXLES						
90-92.5	BRONCO II	STD 3.08-UP	708039	707168X	707167X	1.18/27
90-94.5	EXPLORER	STD 3.08-UP	708039	707168X	707167X	1.18/27
90-97.5	RANGER NON-ABS	STD 3.08-UP	708039	707168X	707167X	1.18/27
MODEL D35IFS STYLE W/ CV JOINT FRONT AXLES						
95-98.5	EXPLORER	STD 3.08-4.10	707378X	707360X	707379X	1.18/27
98-98.5	RANGER	STD 3.08-4.10	707378X	707360X	707379X	1.18/27
MODEL D44IFS STYLE						
79-82	BRONCO II					
79-82	F150 80 3/4 TON					
79-82	F250 W/ PART TIME TRANSFER CASE					
81	F250 & F350 HD FRONT					
		STD 3.73-DN	706020X	706024X	706027X	1.31/30
		STD 3.92-UP	706021X	706025X	706027X	1.31/30
		T/L 4.10-DN	707115X	707116X	706026X	1.31/30
		T/L 3.92-UP	707150X	707151X	706026X	1.31/30
83-96.5	BRONCO					
83-88	F150 SNOW PLOW					
83-95	F150					
83-85	F250 & F350 HD					
85.5-88	F250 FRONT					
		STD 3.73-DN	706921X	706923X	706925X	1.31/30
		STD 3.92-UP	706945X	706947X	706925X	1.31/30
		T/L 3.73-DN	707147X	707148X	706926X	1.31/30
MODEL D60 STYLE						
78-79	F250					
79-95	F350 FRONT					
		STD 4.10-DN	706180X	706040X	706181X	1.50/35
		T/L 4.56-UP	707097-4X	706039X	707086X (NLA)	1.50/35
MODEL D60* STYLE						
00-02	F350-F450 DRW 4x4 FRONT	STD 4.10-DN	706180X	706040X	706181X	1.50/35
		STD 4.56-UP	706182X	706041X	706181X	1.50/35
		STD 4.10-DN	706703X**	706668X (NLA)	706702X	1.50/35
* REVERSE SPIRAL RING & PINION						
** HEAVY DUTY CASE						

CASES & INTERNAL PARTS KITS

FORD® STYLE - REAR

YEAR	DESCRIPTION	TYPE/RATIO	CASE ASSEMBLY KIT	CASE KIT	INTERNAL KIT	DIA/SPL
MODEL D28 STYLE						
90-97	AEROSTAR	STD 3.54-UP	706974X	706975X	706890X	1.00/23
MODEL D44 STYLE						
79	F100 F150	STD 3.73-DN	706020X	706024X	706027X	1.31/30
		STD 3.92-UP	706021X	706025X	706027X	1.31/30
MODEL D60 STYLE						
79-88	E250,E350, F250, F350 W/ FULL FLOAT (BOLT IN) AXLE					
		STD 4.10-DN	706036X	706040X	706043X	1.31/30
		STD 4.56-UP	706037X	706041X	706043X	1.31/30
		T/L 4.10-DN	708013	708014	707084X	1.31/30
		T/L 4.56-UP	707097X++ (NLA)	706039X	707084X	1.31/30
80-88	E250,E350, F250, F350 W SEMI FLOAT (C-CLIP) AXLE					
		STD 4.10-DN	706840X	706842X	706844X	1.50/35
		T/L 4.10-DN	707096X	706843X	707095X	1.50/35
88-97	E250,E350, F250, F350 W FULL FLOAT (BOLT IN) AXLE					
		STD 4.10-DN	707213X	707214X	706043X	1.31/30
		T/L 4.10-DN	707143X	707144X	707084X	1.31/30
		STD 4.10-DN	707387X	707214X	707389X	1.37/32
89-97.5	E250,E350, F250, F350 W SEMI FLOAT (C-CLIP) AXLE					
		STD 4.10-DN	707211-1X	707212-1X	706844X	1.50/35
		T/L 4.10-DN	707163X	707164X	707095X	1.50/35
97.5-01	E250,E350, F250, F350 W FULL FLOAT (BOLT IN) AXLE					
		STD 4.10-DN	707387-1X	707214-1X	707389X	1.37/32
		T/L 4.10-DN	707432X	707144X	707084-1X (NLA)	1.37/32
97.5-02	E250,E350, F250, F350 W SEMI FLOAT (C-CLIP) AXLE					
		STD 4.10-DN	707211-1X	707212-1X	706844X	1.50/35
		T/L 4.10-DN	707427X	707428X	707435X	1.50/35
MODEL D61 STYLE						
79-87	E250,F250, E350, F350 W FULL FLOAT (BOLT IN) AXLE					
		STD 4.10-DN	706036X	706040X	706043X	1.31/30
		STD 3.33-UP	706399X	706400X	706043X	1.31/30
		T/L 4.10-DN	708013	708014	707084X	1.31/30
		T/L 4.56-UP	707097X++ (NLA)	706039X	707084X	1.31/30
80-83.5	E250,F250, E350, F350 W SEMI FLOAT (C-CLIP) AXLE					
		STD 4.10-DN	706840X	706842X	706844X	1.50/35
		T/L 4.10-DN	707096X	706843X	707095X	1.50/35
++THE RATIO BREAK WHEN USED IN D60 IS 4.56-UP; WHEN USED IN D61 IT IS 4.10-DN						
MODEL D70 STYLE						
97-00.5	HD DRW	STD 4.56-DN	707483X	707484X	706058X	1.50/35
97-01	E350 DRW ABS, E350 SRW WIDE TRACK, E350 SRW CUT AWAY OR CHASSIS DRW & D70 02 E350DRW FULL FLOAT AXLE					
		STD 4.10-DN	707276-1X	707216-1X	707252X	1.37/32
		P/L 4.10-DN	707277-1X	707146-1X	707254X	1.37/32

CASES & INTERNAL PARTS KITS

FORD® STYLE - REAR (CONT.)

YEAR	DESCRIPTION	TYPE/RATIO	CASE ASSEMBLY KIT	CASE KIT	INTERNAL KIT	DIA/SPL
MODEL D70-2U W/ 1/2" OFFSET STYLE						
90-92	UPS ABS STD	STD 4.10-DN	707241X	707216X	707119X	1.50/35
92.5-97	E350 DRW W ABS, E350 SRW CUTAWAY, WIDE TRACK, AND CONTINENTAL BAKERY CHASSIS WABS	STD 4.10-DN	707276X	707216X	707252X	1.37/32
		P/L 4.10-DN	707277X	707146X	707254X	1.37/32
MODEL D70B W 1/2" OFFSET STYLE						
79-83.5	E350, F350 VARIOUS	STD 4.10-DN	706051X	706055X	706058X	1.50/35
		STD 4.56-UP	706052X	706056X	706058X	1.50/35
		P/L 4.10-DN	706049X	706053X	707074X	1.50/35
		P/L 4.56-UP	706050X	706054X	706057X	1.50/35
		NO SPIN 4.10-DN	28286X (NLA)	706083X	NA	1.50/35
		NO SPIN 4.56-UP	28284X (NLA)	706084X	NA	1.50/35
MODEL D70HD STYLE						
00-02	E450 SUPER DUTY DRW ABS E350 DSO	STD 4.56-DN	708075-1	708076-1	708077	1.50/35
		T/L 4.56-DN	2005658	NA	NA	1.50/35
MODEL D70HD W/5/8" OFFSET STYLE						
79-90	E350,E350 MOTORHOME, F350 DSO AMBULANCE,F350 DUAL WHEEL, F350 6 WHEELER	STD 4.10-DN	706064X	706068X	706058X	1.50/35
		STD 4.56-UP	706065X	706069X	706058X	1.50/35
		P/L 4.10 -DN	707028X	707029X	707074X	1.50/35
91-97	E350 MOTORHOME, E350 U-HAUL®STYLE	STD 4.10-DN	707186X	707187X	706058X	1.50/35
		P/L 4.10-DN	707189X	707188X	707074X	1.50/35
MODEL D70U STYLE						
92.5-97	E350 DRW W/ABS, E350 SRW CUTAWAY, WIDE TRACK, AND CONTINENTAL BAKERY CHASSIS WABS	STD 4.10-DN	707276X	707216X	707252X	1.37/32
		P/L 4.10-DN	707277X	707146X	707254X	1.37/32
MODEL D70U W/ 1/2" OFFSET STYLE						
82.5-86	E350 DSO, F350,F350-U-HAUL®STYLE, F350 P/U	STD 4.10-DN	706051X	706055X	706058X	1.50/35
		STD 4.56-UP	706052X	706056X	706058X	1.50/35
		P/L 4.10-DN	706049X	706053X	707074X	1.50/35
		P/L 4.56-UP	706050X	706054X	706057X	1.50/35
		NO SPIN 4.10-UP	28286X (NLA)	706083X	NA	1.50/35
		NO SPIN 4.56-UP	28284X (NLA)	706084X	NA	1.50/35
87-88	E350 DSO, F350,F350-U-HAUL®STYLE, F350 P/U	STD 4.10-DN	706051X	706055X	706058X	1.50/35
		STD 4.56-UP	706052X	706056X	706058X	1.50/35
		P/L 4.10-DN	707073X	707027X (NLA)	707074X	1.50/35
89-92	E350 DRW	STD 4.10-DN	707215X	707216X	706058X	1.50/35

CASES & INTERNAL PARTS KITS

FORD® STYLE - REAR (CONT.)

YEAR	DESCRIPTION	TYPE/RATIO	CASE ASSEMBLY KIT	CASE KIT	INTERNAL KIT	DIA/SPL
MODEL D80 STYLE						
89-89	F350 SUPER DUTY	STD 4.10-UP	707061X	707062X	707063X	1.50/35
90-91	F350 SUPER DUTY	STD 4.10-UP	707184X	707062X	707185X	1.60/37
92-95.5	F450 DRW FULL FLOAT AXLE	STD 4.10-UP	707232X	707230X	707185X	1.60/37
96-02	E350 DRW FULL FLOAT AXLE	STD 4.10-UP	707330X	707230X	707063X	1.50/35
		T/L 4.10-UP	2003548	708053	2003857	1.50/35
96-00	F450 DRW FULL FLOAT, F450					
01-02	F53 MOTORHOME DRW FULL FLOAT	STD 4.10-UP	707394X	707395X	707185X	1.60/37
		T/L 4.10-UP	708097	DYNEER	DYNEER	1.60/37
00	E450 SUPER DUTY DRW ABS	STD 4.10-UP	708031	707395X	707063X	1.50/35
01-02.5	F350 CHASSIS DRW FULL FLOAT AXLE ABS	STD 4.10-UP	708031	707395X	707063X	1.50/35
		T/L 4.10-UP	708170	NA	NA	1.50/35
MODEL F7.5" STYLE						
78-ON	VARIOUS	STD ALL	NA	E7TZ4204A	F7.5BI	1.20/28
78-ON	VARIOUS	T/L ALL	M4204C75	NA	NA	1.20/28
MODEL F8.0" STYLE						
62-79	FORD® CAR	T/L ALL	NA	D3OZ4204A	NA	1.20/28
MODEL F8.8" STYLE						
87-ON	VARIOUS	STD ALL	M4204F3180	E7TZ4204E	F8.8BI	1.32/31
87-ON	VARIOUS	T/L ALL	M4204F318	NA	NA	1.32/31
87-ON	VARIOUS	T/L ALL	M4204F288	NA	NA	1.20/28
87-ON	VARIOUS	T/L ALL	CLUTCH PACK KIT F8.8CPK (1 PER UNIT)			
MODEL F9" STYLE						
57-ON	VARIOUS	STD ALL (4 PINION)	NA	D0OZ4204D	F9-IOH	1.32/31
57-ON	VARIOUS	STD ALL (2PINION)	NA	D0OZ4204D	F9-IO	1.32/31
57-ON	VARIOUS	STD ALL (4 PINION)	NA	D0OZ4204D	F9-IO28H	1.20/28
57-ON	VARIOUS	STD ALL (2 PINION)	NA	D0OZ4204D	F9-IO28	1.20/28
57-ON	VARIOUS	T/L ALL (4 PINION)	D3SZ4026A	D3TZ4204A	F9-IP28H	1.20/28
57-ON	VARIOUS	T/L ALL (2 PINION)	NA	NA	F9-IP28	1.20/28
57-ON	VARIOUS	T/L ALL (4 PINION)	D4TZ4026A	D3TZ4204A	F9-IPH	1.32/31
57-ON	VARIOUS	T/L ALL (2 PINION)	NA	NA	F9-IP	1.32/31
57-ON	VARIOUS	T/L ALL	CLUTCH PACK KIT (4 TAB) F9-CPK (1 PER UNIT)			
MODEL F9.75" STYLE						
97-ON	EXPEDITION/NAVIGATOR, E150,E250, E350, F150	STD ALL	NA	F75Z4204AA	NA	1.37/34
97-ON	EXPEDITION/NAVIGATOR, E150,E250, E350, F150 REAR	LKR ALL	F75Z4026AA	NA	NA	1.37/34
	CLUTCH PACK KIT 3L1Z4947AB					

CASES & INTERNAL PARTS KITS

FORD® STYLE - REAR (CONT.)

YEAR	DESCRIPTION	TYPE/RATIO	CASE ASSEMBLY KIT	CASE KIT	INTERNAL KIT	DIA/SPL
MODEL F10.25" STYLE						
83-99	F350,F450 REAR (2 PINION) STD ALL		F10.25L	E7TZ4204C	F10.25BI	1.50/35
83-99	F350,F450 REAR (2 PINION) LKR ALL		73109X	E7TZ4204D	NA	1.50/35
	CLUTCH PACK KIT 72960X					
MODEL F10.5" STYLE						
99-ON	F350,F450 REAR (2 PINION) STD ALL		F10.25L	E7TZ4204C	F10.25BI	1.50/35
99-ON	F350,F450 REAR (2 PINION) LKR ALL		73109X	NA	NA	1.50/35
	CLUTCH PACK KIT 72960X					

GMC® STYLE - FRONT

MODEL D44 STYLE						
78-80	K20;	STD 3.73-DN	706020X	706024X	706027X	1.31/30
78	BLAZER, K10	STD 3.73-DN	706020X	706024X	706027X	1.31/30
78-80	K20	STD 3.92-UP	706021X	706025X	706027X	1.31/30
78	BLAZER, K10	STD 3.92-UP	706021X	706025X	706027X	1.31/30
MODEL D60 STYLE						
79-85	GM® K30	STD 4.10-DN	706180X	706040X	706181X	1.50/35
		STD 4.56-UP	706182X	706041X	706181X	1.50/35
		T/L 4.56-UP	707097-4X	706039X	707086X (NLA)	1.50/35
88-91	V30	STD 4.10-DN	706180X	706040X	706181X	1.50/35
MODEL GM7.25IFS STYLE						
83-ON	1/2 TON TRK,VAN	STD 3.42-UP	NA	GM7.25IFSE	GM7.25BIFS	1.16/26
MODEL GM7.6IFS STYLE						
04-ON	1/2 TON 4WD	STD ALL	NA	GM7.6IFSE	GM7.6BIFS	1.20/28
MODEL GM8.25IFS STYLE						
88-03	1/2 TON 4WD/AWD	STD ALL		26018131	GM10BIFS	1.20/28
MODEL GM9.25IFS STYLE						
88-ON	3/4-1 TON 4WD/AWD	STD ALL	NA	14038087	GM9.5BI	1.37/33

GMC® STYLE - REAR

YEAR	DESCRIPTION	TYPE/RATIO	CASE ASSEMBLY KIT	CASE KIT	INTERNAL KIT	DIA/SPL
MODEL D36ICA STYLE						
85-87	CORVETTE®	T/L 2.73-DN	74224X*	707015X	707226X (NLA)	1.18/27
85-87	CORVETTE®	T/L 3.07-3.54	74230X*	707016X	707226X (NLA)	1.18/27
85-87	CORVETTE®	T/L3.07-3.73	74229X*	41232	707225X	1.31/30
*ASSEMBLY DOES NOT INCLUDE SHIMS, BEARINGS OR DRIVE GEAR SCREWS						
MODEL D44 STYLE						
84-85	F CAR	T/L 3.73-DN	707132X	707133X (NLA)	707134X (NLA)	1.31/30
92.5-94	F CAR	T/L 3.73-DN	707132X	707133X (NLA)	707134X (NLA)	1.31/30

CASES & INTERNAL PARTS KITS

GMC® STYLE - REAR (CONT.)

YEAR	DESCRIPTION	TYPE/RATIO	CASE ASSEMBLY KIT	CASE KIT	INTERNAL KIT	DIA/SPL
MODEL D60 STYLE						
79-91	G-VAN	STD 4.10-DN	706180X	706040X	706181X	1.50/35
79-91	G-VAN	STD 4.56-UP	706182X	706041X	706181X	1.50/35
MODEL D70 STYLE						
79-94	VARIOUS MODELS AS FOLLOWS: C30, SRW & DRW G VAN, G300, K30, P30, P300, R30 & V30					
MODEL D70B W/ 1/2" OFFSET STYLE						
79-83	G300 W 146" WB	STD 4.10-DN	706051X	706055X	706058X	1.50/35
79-83	G300 W 146" WB	STD 4.56-UP	706052X	706056X	706058X	1.50/35
MODEL D70-3HD W/ 5/8" OFFSET STYLE						
85-89	SRW C/K30	STD 4.56-UP	706065X	706069X	706058X	1.50/35
88-91.5	DRW C/K30	STD 4.56-UP	706065X	706069X	706058X	1.50/35
89.5-91.5	G VAN	STD 4.56-UP	706065X	706069X	706058X	1.50/35
MODEL D70HD W/ 5/8" OFFSET STYLE						
79-81	C30, P300	STD 4.10-DN	706064X	706068X	706058X	1.50/35
82-86	C/K30					
982.5-90	P30					
85-89	P300 UPS					
87-91	R/V30					
		STD 4.10-DN	706906X	706908X (NLA)	706058X	1.50/35
		STD 4.56-UP	706065X	706069X	706058X	1.50/35
90-94	P300UPS	STD 4.56-UP	707118X	706909X	707119X	1.50/35
MODEL D80 STYLE						
92-98.5	MOTORHOME W/ DISK BRAKES, GMT 455, P TRUCK					
		STD 4.10-UP	707061X	707062X	707185X	1.50/35
		STD 4.10-UP	707184X	707062X	707185X	1.60/37
		STD 4.10-UP	707362X	707363X	707280X	1.60/37
MODEL GM7.5" STYLE						
75-88	CAR	STD 3.23-UP	NA	GM7.5E	GM7.5BI	1.16/26
82-88	TRK	STD 3.23-UP	NA	GM7.5E	GM7.5BI	1.16/26
MODEL GM7.5" & GM7.6" STYLE						
88-ON	CAR & TRK	STD 3.08-DN	NA	26033478	GM7.6BI	1.20/28
88-ON	CAR & TRK	LKR 3.08-DN		NA	NA	1.20/28
88-ON	CAR & TRK	STD 3.23-UP	NA	26033477	GM7.6BI	1.20/28
88-ON	CAR & TRK	LKR 3.23-UP	26046172	NA	NA	1.20/28
MODEL GM8.0" STYLE						
02-ON	2WD-4WD MID-SIZE	STD ALL	NA	GM8.0E	GM8.0BI	1.20/28
02-ON	2WD-4WD MID-SIZE	LKR ALL	GM8.0LKR	NA	NA	1.20/28

CASES & INTERNAL PARTS KITS

GMC® - REAR (CONT.)

YEAR	DESCRIPTION	TYPE/RATIO	CASE ASSEMBLY KIT	CASE KIT	INTERNAL KIT	DIA/SPL
MODEL GM8.5" & GM® 8.6" STYLE						
82-87	2WD-4WD FULL SIZE CAR, TRK & UTILITY	STD 2.73-UP	GM10L-28	26010481	GM10BI	1.20/28
88-99	2WD-4WD FULL SIZE CAR, TRK & UTILITY	STD 2.73-UP	GM10L-30	26010481	GM10BI-30	1.31/30
MODEL GM8.6" STYLE						
99-ON	2WD-4WD FULL SIZE CAR, TRK & UTILITY	LKR 2.73-UP	GM8.6LKR	NA	NA	1.31/30
99 MID-00	2WD-4WD FULL SIZE CAR, TRK & UTILITY	STD 2.73-UP	NA	GM8.6E	GM8.6BI	1.31/30
MID-00 UP	2WD-4WD FULL SIZE CAR, TRK & UTILITY	STD 2.73-UP	NA	GM8.6LE	GM8.6BIL	1.31/30
MODEL GM8.875" STYLE						
64-82	1/2 TON-3/4 12 BOLT TRK	STD 3.42-DN	NA	6258088	GM12BI	1.31/30
64-82	1/2 TON-3/4 12 BOLT TRK	STD 3.73-UP	NA	6258086	GM12BI	1.31/30
MODEL GM9.5" STYLE						
81-ON	SEMI FLOAT 3/4 TON -1 TON 14 BOLT	STD ALL	NA	14038087	GM9.5BI	1.37/33
		LKR ALL	GM9.5LKR	NA	NA	1.37/33
MODEL GM10.5" STYLE						
73-01	FULL FLOAT 3/4 TON -1 TON 14 BOLT	STD 4.10-DN	NA	6258336	GM14BI	1.50/30
		STD 4.56-UP	NA	6258340	GM14BI	1.50/30
		LKR 4.10-DN	GM10.5LKRH	NA	NA	1.50/30
		LKR 4.56-UP	GM10.5LKRL	NA	NA	1.50/30
MODEL GM11.5" STYLE						
01-ON	FULL FLOAT 3/4 TON -1 TON 14 BOLT	STD ALL	NA	GM11.5E	GM11.5BI	1.50/30
		LKR ALL	GM11.5LKR	NA	NA	1.50/30

JEEP®/ EAGLE® STYLE - FRONT

YEAR	DESCRIPTION	TYPE/RATIO	CASE ASSEMBLY KIT	CASE KIT	INTERNAL KIT	DIA/SPL
------	-------------	------------	-------------------	----------	--------------	---------

MODEL CODES:

XJ=CHEROKEE/COMANCHE YJ/TJ= WRANGLER WJ & ZJ=GRAND CHEROKEE J10= PICK-UP TRUCKCJ=CIVILIAN JEEP

MODEL D30 STYLE

78-83	CJ5 & CJ7	STD 3.54-DN	706003X	706007X	706010X	1.18/27
82-87	CJ7 & CJ8	STD 3.73-UP	706004X	706008X	706010X	1.18/27
85-89	XJ	STD 3.54-DN	706931X	706933X	706935X	1.18/27
84-89	XJ, YJ	STD 3.73-UP	706932X	706008X	706820X	1.18/27
90-01	XJ					
92-96	YJ					

CASES & INTERNAL PARTS KITS

JEEP®/ EAGLE® STYLE - FRONT (CONT.)

YEAR	DESCRIPTION	TYPE/RATIO	CASE ASSEMBLY KIT	CASE KIT	INTERNAL KIT	DIA/SPL
		STD 3.55-DN	707158X	706933X	707160X	1.18/27
		STD 3.73-UP	707159X	706934X	707160X	1.18/27
MODEL D30 STYLE WITH COLLAPSIBLE SPACER						
92.5-02	ZJ					
97-02	TJ					
		STD 3.55-DN	707158X	706007X	707160X	1.18/27
		STD 3.73-UP	707159X	706008X	707160X	1.18/27
01	XJ LHD & RHD DIESEL ABS	STD 3.55-DN	707158X	706007X	707160X	1.18/27
		STD 3.73-UP	707159X	706008X	707160X	1.18/27
MODEL SUPER D30 STYLE						
99-01	WJ	STD 3.55-DN	707158-1X	706007-1X	707160X	1.18/27
		STD 3.73-UP	707159-1X	706008-1X (NLA)	707160X	1.18/27
		HL 3.73-UP	85282	NA	NA	1.18/27
MODEL D44 STYLE						
78-85	WAGONEER, CHEROKEE					
78-87.5	J10, J20					
78-79	HONCHO					
78-85	WIDE TRACK CHEROKEE					
85-92	GRAND WAGONEER					
		STD 3.73-DN	706020X	706024X	706027X	1.31/30
		STD 3.92-UP	706021X	706025X	706027X	1.31/30

JEEP®/ EAGLE® STYLE - REAR

YEAR	DESCRIPTION	TYPE/RATIO	CASE ASSEMBLY KIT	CASE KIT	INTERNAL KIT	DIA/SPL
MODEL D35 STYLE						
85.5-86	XJ UTILITY	STD 3.54-UP	74209X	43218 (NLA)	707247X	1.18/27
86	XJ UTILITY, P/U	T/L 3.54-UP	74210X	707243X	707349X	1.18/27
87-93.5	XJ UTILITY, P/U, TRUCK					
90-93.5	YJ					
93-94	ZJ					
		STD 2.73-3.31	74214X	(NLA)	707247X	1.18/27
		STD 3.54-UP	74209X	75054X (NLA)	707247X	1.18/27
		T/L 2.73-3.31	74215X	707242X	707173X	1.18/27
		T/L 3.54-UP	74210X	707243X	707349X	1.18/27
92.5	XJ	STD 3.54-UP	74211X	43218 (NLA)	707247X	1.18/27-
93-01	XJ UTILITY, YJ, ZJ & TJ	STD 2.73-3.31	75053X	44649	707321X	1.18/27
		STD 3.54-UP	75054X (NLA)	44590	707321X	1.18/27
		T/L 2.73-3.31	74215X	707242X	707173X	1.18/27
		T/L 3.54-UP	74210X	707243X	707349X	1.18/27
99-99.5	WJ w/ ABS	STD 3.54-UP	708109	48178	707321X	1.18/27
		T/L 3.54-UP	708110	708137 (NLA)	707349X	1.18/27

CASES & INTERNAL PARTS KITS

JEEP®/ EAGLE® STYLE - REAR (CONT.)

YEAR	DESCRIPTION	TYPE/RATIO	CASE ASSEMBLY KIT	CASE KIT	INTERNAL KIT	DIA/SPL
MODEL D44 STYLE						
77-85	CJ,J10,XJ, YJ/TJ	STD 3.73-DN	706020X	706024X	706027X	1.31/30
		STD 3.92-UP	706021X	706025X	706027X	1.31/30
		T/L 4.10-DN	707115X	707116X	706026X	1.31/30
		T/L 3.92-UP	707150X	707151X	706026X	1.31/30
96-99	CJ,J10,XJ, YJ/TJ	STD 3.73-DN	707045X	706024X	707047X	1.31/30
		STD 3.92-UP	707046X	706025X	707047X	1.31/30
		T/L 4.10-DN	707115X	707116X	706026X	1.31/30
		T/L 3.92-UP	707150X	707151X	706026X	1.31/30
01	TJ NON-ABS	STD 3.92-UP	706021-1X (NLA)	706615X	707125-1X (NLA)	1.31/30
		T/L 4.10-DN	707115X	707116X	706026X	1.31/30
MODEL SUPER D44 STYLE						
99-00	WJ, ZJ W/ABS	STD 3.73-DN	707382X	43771 (NLA)	707384X	1.31/30
		T/L 3.73-DN	707383X	43775 (NLA)	707385X	1.31/30
		H/L 3.31-4.11	NA	76740X	N/A	1.31/30
MID 00-ON WJ W/ABS		STD 3.31-4.11	708107	51256	707384X	1.31/30
		T/L 3.31-4.11	708108	51257 (NLA)	707385X	1.31/30
		H/L ALL	NA	84084	NA	1.31/30
MODEL D60 STYLE						
78-88	J20	STD 4.10-DN	706036X	706040X	706043X	1.31/30
		STD 4.56-UP	706037X	706041X	706043X	1.31/30
		T/L 4.10-DN	708013	708014	707084X	1.31/30
		T/L 4.56-UP	707097X (NLA)	706039X	707084X	1.31/30
82.5-82	CJ20	STD 4.10-DN	706180X	706040X	706181X	1.50/35
		T/L 4.10-DN	707090-4X	707123X	707086X (NLA)	1.50/35
		T/L 4.56-UP	707097-4X	706039X	707086X (NLA)	1.50/35
MODEL D70 STYLE						
85	CJ 10A MILITARY	STD 4.56-UP	706052X	706056X	706058X	1.50/35
		P/L 4.56-UP	706050X	706054X	706057X	1.50/35

RING GEAR SPACERS

PART#	DESCRIPTION
075050	SPACER RING 7.5 GM
082050	SPACER R.G. 10 BOLT CAR 8.2"
085050	SPACER R.G. 10 BOLT
087050	SPACER R.G. 12 BOLT CAR
088050	SPACER R.G. 12 BOLT TRUCK

PERFORMANCE GEAR OIL - LIMITED SLIP

PART#	DESCRIPTION
MGP 75W140	SYNTHETIC GEAR OIL 75W-140 GL-6 WITH LIMITED-SLIP ADDITIVE 1 U.S. QUART
MGPLSF	LIMITED SLIP FRICTION MODIFIER TYPE F
MGPLSG	LIMITED SLIP FRICTION MODIFIER TYPE G

ARB®

AUBURN®

EATON®/DETROIT LOCKER®



Positioner Units

ARB® AIR LOCKER® MANUAL LOCKING DIFFERENTIALS

CHEVROLET®/ GMC®/ HUMMER®

Vehicle/Model	Axle Loc'n	Year	Description	Shaft Diameter	Shaft Spline	Ratio	ARB Part No.
10/1500 Series, C, G, K, P, Blazer, Jimmy, Yukon, Suburban ¹ , Vans	Front	To 1980	Dana M44, 3600lb	33.3 (1.31")	30	3.92 & UP 3.73 & DN	RD116 ⁶ RD117
		1977-89	GM 10 bolt	30.5 (1.20")	28	2.73 & UP	RD83 ²
	Rear	1989-96	GM 10 bolt, 8.5" dia. RG, semi floating	33.3 (1.31")	30	2.73 & UP	RD84 ⁷
		1982-89	GM 10 bolt, 8.5" dia. RG, semi floating	30.5 (1.20")	28	2.73 & UP	RD83 ²
		1982 on	GM 14 bolt, 9.5" dia. RG, semi floating	34.8 (1.37")	33	All	RD40
		To 1982	GM 12 bolt, 8.875" dia. RG, semi floating	33.3 (1.31")	30	3.73 & UP	RD12
20/2500 Series, C, G, K, P, Cab Chassis, Pickup, Suburban ¹ , Rally, Sportvan	Front	To 1980	Dana 44	33.3 (1.31")	30	3.92 & UP 3.73 & DN	RD116 ⁶ RD117
		1977-89	GM 10 bolt	30.5 (1.20")	28	2.73 & UP	RD83 ²
	Rear	1982 on	GM 14 bolt, 9.5" dia. RG, 4800-5700lb	34.8 (1.37")	33	All	RD40
		1980-93	GM 10 bolt, 8.5" dia. RG, semi floating	30.5 (1.20")	28	2.73 & UP	RD83 ²
		1975-77	Dana 60HD	38.1 (1.50")	35	4.56 & UP 4.10 & DN	RD35 RD36
			Dana 60	33.3 (1.31")	30	4.56 & UP 4.10 & DN	RD21 RD22
		1973 on	GM 14 bolt, 10.5" dia. RG full floating	39.0 (1.56")	30	All ⁵	RD114
	30/3500 Series, C, K, G, P, RV, Pickup, Suburban ¹ , Rally, Sportvan	Front	1977-90	Dana 60HD	38.1 (1.50")	35	4.56 & UP 4.10 & DN
1989 on			GM IFS 9.25" dia. RG	34.8 (1.37")	33	All	RD51
Rear		1988 on	GM 14 bolt, 9.5" dia. RG, semi floating	34.8 (1.37")	33	All	RD40
		1976 on	Dana 70HD ^{3,4}	38.1 (1.50")	35	4.56 & UP 4.10 & DN	RD53 ⁵ RD54
			Dana 70U	38.1 (1.50")	35	4.56 & UP 4.10 & DN	RD65 RD66
		1975-86	Dana 60HD, full floating	38.1 (1.50")	35	4.56 & UP 4.10 & DN	RD35 RD36
		1973 on	GM 14 bolt, 10.5" dia. RG, full floating	39.0 (1.56")	30	All ⁵	RD114
3500 HD		Rear	1992 on	Dana 80	38.1 (1.50")	35	3.73 & DN
				40.6 (1.60")	37	3.73 & DN	RD91
	1992 on		GM 14 bolt, 10.5" dia. RG full floating	39.0 (1.56")	30	All ⁵	RD114
Hummer H1	Front	1983 on	AMC Model 20, 8.875" dia. RG	31.8 (1.25")	29	2.73	RD47 ⁴
	Rear	1983 on	AMC Model 20, 8.875" dia. RG	31.8 (1.25")	29	2.73	RD47 ⁴
Hummer H2	Front	2003 on	GM IFS 9.25" dia. RG	34.8 (1.37")	33	All	RD51
	Rear	2003 on	GM 14 bolt, 9.5" dia. RG, semi floating	34.8 (1.37")	33	All	RD40
Hummer H3	Front	2006 on	GM IFS 9.25" dia. RG	34.8 (1.37")	33	All	RD51
	Rear	2006 on	TBD				TBD

¹ Suburban kept 10 bolt front and rear ends until 1991. Keep in mind spline change in 1989.

² If vehicle was manufactured in 1989/90 check spline count to determine which model is needed.

³ Some 1988 and newer trucks use a unique Dana 70-3HD. Special fitment is required.

⁴ 1999 and newer axle shafts may need .005" dia. removed for proper fit.

⁵ 4.56 & UP ratios must use 'thick' type high offset gearset.

⁶ See performance section of this guide for non-standard upgrade model(s) available for this application.

ARB® AIR LOCKER® MANUAL LOCKING DIFFERENTIALS

CHRYSLER®/ JEEP®

Vehicle/Model	Axle Loc'n	Year	Description	Shaft Diameter	Shaft Spline	Ratio	ARB Part No.
CJ(5, 6, 7 & 8), YJ & TJ Wrangler, XJ Cherokee, XJ Wagoneer, ZJ, WJ Grand Cherokee ^{3,4}	Front	1971 on	Dana 30	29.5 (1.16")	27	3.73 & UP 3.54 & DN	RD100 ^{4,7} RD101 ⁴
	Rear	1990 on	Dana 35 ¹ , C-clip, XJ, YJ, ZJ, TJ, WJ	29.5 (1.16")	27	2.73-3.31 3.54 & UP	RD103 ⁶ RD102 ^{6,7}
		1997-00 to 1996	Chrysler 8.25" dia. RG, C-clip Chrysler 8.25" dia. RG, C-clip	30.7 (1.21") 29.5 (1.16")	29 27	All	RD93 RD112 ⁶
		1997 on	Dana 44, TJ model only ³	33.3 (1.31")	30	3.92 & UP 3.73 & DN	RD116 ^{6,7} RD117 ⁶
	Rear	1985-89	Dana 35 ¹ , non C-clip	29.5 (1.16")	27	2.73-3.31 3.54 & UP	RD103 RD102 ⁷
		1987-89	Dana 44, Commanche truck	33.3 (1.31")	30	3.92 & UP 3.73 & DN	RD116 ⁷ RD117
	Rear	1986-91	Dana 44, XJ w/ metric ton package	33.3 (1.31")	30	3.92 & UP 3.73 & DN	RD116 ⁷ RD117
		1976-85	AMC Model 20, 8.875" dia. RG	31.8 (1.25")	29	3.08 & UP 2.73 & DN	RD60 RD47
	Rear	1969-75,86	Dana 44-3R	33.3 (1.31")	30	3.92 & UP 3.73 & DN	RD116 ⁷ RD117
		1966-68	Dana 44-R	31.8 (1.25")	19	3.92 & UP 3.73 & DN	NA NA
JK Jeep Wrangler (not Rubicon models)	Front	2007 on	Dana 30	29.5 (1.16")	27	3.73 & UP 3.54 & DN	RD100 ⁷ RD101
	Rear	2007 on	Dana 44	33.3 (1.31")	30	All	RD117 ⁷
KJ Jeep Liberty	Front	2001 on	Dana 30 IFS	29.5 (1.16")	27	3.73 & UP 3.54 & DN	RD100 ⁷ RD101
	Rear	2001 on	Chrysler 8.25" dia. RG, C-clip	30.7 (1.21")	29	All	RD93 ⁶
Full size AMC Cherokee, Grand Wagoneer	Front	1974-93	Dana M44-1F	33.3 (1.31")	30	3.92 & UP 3.73 & DN	RD116 ⁷ RD117
		1971-73	Dana 30	29.5 (1.16")	27	3.73 & UP 3.54 & DN	RD100 ⁷ RD101
	Rear	1986-93	Dana 44	33.3 (1.31")	30	3.92 & UP 3.73 & DN	RD116 ⁷ RD117
		1980-86	AMC Model 20, 8.875" dia. RG	31.8 (1.25")	29	3.08 & UP 2.73 & DN	RD60 ² RD47
	Rear	1969-79	Dana M44-3R	33.3 (1.31")	30	3.92 & UP 3.73 & DN	RD116 ⁷ RD117
		1966-69	Dana M44-R	31.8 (1.25")	19	3.92 & UP 3.73 & DN	NA NA
J10, Light Truck, FC150, 170, Honcho	Front	1971-88	Dana M44-1F	33.3 (1.31")	30	3.92 & UP 3.73 & DN	RD116 ⁷ RD117
	Rear	1980-88	AMC Model 20, 8.875" dia. RG	31.8 (1.25")	29	3.08 & UP 2.73 & DN	RD60 RD47
		1970-88	Dana M44-R	33.3 (1.31")	30	3.92 & UP 3.73 & DN	RD116 ⁷ RD117
		1966-69	Dana M44-R	31.8 (1.25")	19	3.92 & UP 3.73 & DN	NA NA
J20, Medium Truck, J30, Heavy Truck	Front	1970-88	Dana M44-1F	33.3 (1.31")	30	3.92 & UP 3.73 & DN	RD116 ⁷ RD117
	Rear	1974-88	Dana M60-3R	33.3 (1.31")	30	4.56 & UP 4.10 & DN	RD21 RD22
		1969-73	Dana M60-2R	38.1 (1.50")	35	4.56 & UP 4.10 & DN	RD35 RD36
WK/WH Grand Cherokee	Front	2005 on	Chrysler 8.25" dia. RG, non-C-clip	30.7 (1.21")	29	TBA	NA
	Rear	2005 on	Chrysler 8.25" dia. RG, non-C-clip	30.7 (1.21")	29	TBA	NA

¹ The "C" in "Dana 35C" does not represent C-clip. They are manufactured in both C-clip and non C-clip models. Air Locker model RD102, RD103 and RD105 suits both types of axles regardless.

² Air Locker model RD60 has a floating thrust block to suit vehicles with tapered axles. The thrust block must not be used when swapping to full floating axles and some one-piece axle shaft conversions.

³ No application for differentials with aluminium housings.

⁴ Quadra-drive traction control vehicles require non-Quadra-drive axle shaft replacements for Air Locker installation.

⁵ Pre-1997 8.25" axle assemblies with 27 spline axle shafts will accept newer 29 spline shafts if RD93 is fitted.

⁶ Newer OEM Dana 35, Dana 44 & Chrysler 8.25" ring gears have 7/16" bolts. Air Locker flange holes must be reamed larger to suit.

⁷ See performance section of this guide for non-standard upgrade model(s) available for this application.

ARB® AIR LOCKER® MANUAL LOCKING DIFFERENTIALS

DODGE®

Vehicle/Model	Axle Loc'n	Year	Description	Shaft Diameter	Shaft Spline	Ratio	ARB Part No.
100, 150, 200, 250, A, B, D, W	Front	All	Dana 44, half ton truck	33.3 (1.31")	30	3.91 & UP 3.73 & DN	RD116 ^{3,4} RD117 ⁴
		1975-93	Dana 60, three quarter ton truck	33.3 (1.31")	30	4.56 & UP 4.10 & DN	RD21 RD22
		1989-93	Dana 70, three quarter ton truck	35.8 (1.41")	32	4.56 & UP	RD97
		1988-95 & 1971-82	Dana 60HD, three quarter ton truck	38.1 (1.50")	35	4.56 & UP 4.10 & DN	RD98 RD35 RD36
	Rear	1991-93	Dana 70, three quarter ton truck	35.8 (1.41")	32	4.56 & UP	RD97
		1988-93	Dana 70U, three quarter ton truck	38.1 (1.50")	35	4.10 & DN 4.56 & UP	RD98 RD65 RD66
		1983-93	Dana 60 ¹	33.3 (1.31")	30	3.54	RD22
		1972-82	Dana 60	33.3 (1.31")	30	4.56 & UP	RD21
						4.10 & DN	RD22
300, 350, 400, B, C, M, W	Front	1976-95	Dana 60HD	38.1 (1.50")	35	4.56 & UP 4.10 & DN	RD35 RD36
		1971-74	Dana 70	35.8 (1.41")	32	4.56 & UP	RD97
		1955 on	Dana 60	33.3 (1.31")	30	4.10 & DN 4.56 & UP	RD98 RD21 RD22
	Rear	1979-93	Dana 70HD	38.1 (1.50")	35	4.56 & UP	RD53 ³
						4.10 & DN	RD54
		1971-93	Dana 70	35.8 (1.41")	32	4.56 & UP 4.10 & DN	RD97 RD98
		1993	Dana 80	38.1 (1.50") 40.6 (1.60")	35 37	3.73 & DN 3.73 & DN	RD80 RD91
Dakota V6, 1500/2500 Van	Front	1997 on	Dana 30 (non-standard)	29.5 (1.16")	27	-	NA
	Rear	1997 on to 1996	Chrysler 8.25" dia. RG, C-clip Chrysler 8.25" dia. RG, C-clip	30.7 (1.21") 29.5 (1.16")	29 27	All All	RD93 ⁴ RD112 ²
RAM 1500	Front	1994-03	Dana 44	33.3 (1.31")	30	3.91 & UP 3.73 & DN	RD116 ^{3,4} RD117 ⁴
	Rear	1994 on	Chrysler 9.25" dia. RG		31		NA
RAM 2500, 3500	Front	1994-02	Dana 60	35.8 (1.41")	32	4.56 & UP 4.10 & DN	RD95 RD96
		2003 on	AA&M 9.25"	34.8 (1.37")	33	All	RD51
	Rear	1994-02	Dana 70	35.8 (1.41")	32	4.56 & UP 4.10 & DN	RD97 RD98
		1994-02	Dana 80	38.1 (1.50")	35	3.73 & DN	RD80
			Dana 80	40.6 (1.60")	37	3.73 & DN	RD91
		2003 on	AA&M 11.5"	39.0 (1.56")	30	All	NA ⁵

¹ 1988 and newer half ton petrol trucks may have either a Chrysler 9.25" or Dana 60. Check spline count.

² Pre-1997 8.25" axle assemblies with 27 spline axle shafts will accept newer, stronger 29 spline shafts if RD93 is used.

³ See performance section of this guide for non-standard upgrade model(s) available for this application.

⁴ Newer OEM Chrysler 8.25" and Dana 44 ring gears may have 7/16" bolts. Air Locker flange holes must be reamed larger to suit.

⁵ Available 2007.

Motive Gear®

ARB® AIR LOCKER® MANUAL LOCKING DIFFERENTIALS

FORD®

Vehicle/Model	Axle Loc'n	Year	Description	Shaft Diameter	Shaft Spline	Ratio	ARB Part No.
Maverick (Nissan Patrol GQ)	Front	All	H233B	32.0 (1.26")	31	All	RD78A ⁶
	Rear	All	H233B		33	All	RD24
F100/150 Pickup, E100/150 Van (2WD), Bronco	Front	1997 on	Ford 8.8" dia. RG, IFS	30.5 (1.20")	28	All	RD82
		1983-96	Dana 44, C-clip	33.3 (1.31")	30	3.92 & UP 3.73 & DN	RD116 ^{1,4} RD117 ¹
		To 1982	Dana 44	33.3 (1.31")	30	3.92 & UP 3.73 & DN	RD116 ⁴ RD117
	Rear	1976-86	Ford 9" dia. RG	33.5 (1.32")	31	All	RD119 ⁴
		1977-79	Dana 44	33.3 (1.31")	30	3.92 & UP 3.73 & DN	RD116 ⁴ RD117
		To 1979	Ford 9" dia. RG, 28 spline	30.5 (1.20")	28	All	NA
		1997 on	Ford 9.75" dia. RG	-	-	-	NA
	1983 on	Ford 8.8" dia. RG	33.5 (1.32")	31	All	RD81	
F250 Pickup, E250 Van (2WD)	Front ³	1997-98	Ford 8.8" dia. RG, 3750lb	33.5 (1.32")	31	All	RD81
				30.5 (1.20")	28	All	RD82
		1983-96	Dana 44, C-clip	33.3 (1.31")	30	3.92 & UP 3.73 & DN	RD116 ^{1,4} RD117 ¹
		To 1983	Dana 44	33.3 (1.31")	30	3.92 & UP 3.73 & DN	RD116 ⁴ RD117
		1980-06	Dana 50, IFS w/ HD suspension option	33.3 (1.31")	30	All	RD50
		2000 on	Dana 60, full floating	38.1 (1.50")	35	4.56 & UP 4.10 & DN	RD35 RD36
	Rear	1985 on	Ford 10.25" x 10.5" dia. RG, 6250lb, full floating	38.1 (1.50")	35	All	RD37
		1975-84	Dana 60, full floating	33.3 (1.31")	30	4.56 & UP 4.10 & DN	RD21 RD22
		1995-96	Dana 60, full floating	38.1 (1.50")	35	4.56 & UP	RD35
						4.10 & DN	RD36
2002 on		Dana 70, full floating	35.8 (1.41")	32	4.56 & UP 4.10 & DN	RD97 RD98	
1981 on		Dana 60, semi floating (C-clip)	38.1 (1.50")	35	4.56 & UP 4.10 & DN	RD42 RD43	
F350 Pickup, E350 Van (2WD)	Front	1980-04	Dana 50	33.3 (1.31")	30	All	RD50
		1997-00	Non-HD option	33.3 (1.31")	30	All	RD50
		1986 on	Dana 60	38.1 (1.50")	35	All	RD36 ²
						4.56 & UP	RD35
	Rear	1985 on	Ford 10.25" dia. RG, 6250lb, full floating	38.1 (1.50")	35	All	RD37
		2000-01	Dana 60 (dual rear wheel axle models)	38.1 (1.50")	35	4.56 & UP 4.10 & DN	RD35 RD36
		1988 on	Dana 60, full floating	38.1 (1.50")	35	4.56 & UP	RD35
						4.10 & DN	RD36
		1975-85	Dana 70HD, 10.5" dia. RG	38.1 (1.50")	35	4.56 & UP	RD53 ⁴
						4.10 & DN	RD54
	1975-85	Dana 70U	38.1 (1.50")	35	4.57 & UP	RD65	
				4.10 & DN	RD66		
	1973-79	Dana 60, full floating	33.3 (1.31")	30	4.56 & UP 4.10 & DN	RD21 RD22	
Explorer, Ranger (US), Aerostar (2WD)	Front	1990-97	Dana 35 (V6 only)	29.5 (1.16")	27	2.73-3.31 3.54 & UP	RD103 ¹ RD102 ^{1,4}
		1998 on	Dana 35 (non-standard)				NA
	Rear	1990 on	Ford 8.8" dia. RG, C-clip	30.5 (1.20") 33.5 (1.32")	28 31	All	RD82 RD81
Courier, Ranger (Thai)	Front	All					NA
	Rear	All	4 cylinder, Dana banjo type	30.8 (1.21")	30	All	RD123 ⁵
				6 cylinder, Salisbury type	32.8 (1.29")	30	All
	2006 on	Dana 44, 32 spline	35.8 (1.41")	32	TBD	RD143 ⁷	
Expedition	Front	1997 on	Ford 8.8" dia. RG, C-clip	30.5 (1.20")	28	All	RD82
	Rear	1997 on	Ford 9.75" dia. RG				NA
F450/550 Pickup, Super Duty Van (2WD), E/F350 Dually	Front	1997 on	Dana 60	38.1 (1.50")	35	4.56 & UP 4.10 & DN	RD35 RD36
	Rear	1996 on	Dana 80	40.6 (1.60")	37	All	RD91
	1988 on	Dana 80	38.1 (1.50")	35	All	RD80	

¹ The C-clip used in the OE differential cannot be used in the Air Locker. Refer to installation guide or Air Locker Service & Parts Manual for alternative 'spring retained stub' fitment method.

² Reverse rotation Dana 60 front ends with aftermarket ring & pinion sets all use RD36 regardless of the gear ratio.

³ Dana 44's, 50's, 60's and Ford 8.8's were all found in these vehicles. Use housing markings and axle splines to identify.

⁴ See performance section of this guide for non-standard upgrade model(s) available for this application.

⁵ Suits the shimmed type third member (not the early adjuster nut type) which can be visually identified by the Dana logo cast into the third member between the two fins of the right hand side.

⁶ Floating thrust block(s) are included but should ONLY be installed on semi-floating axle assemblies.

⁷ Available mid-2007.

ARB® AIR LOCKER® MANUAL LOCKING DIFFERENTIALS

HOLDEN / ISUZU®

Vehicle/Model	Axle Loc'n	Year	Description	Shaft Diameter	Shaft Spline	Ratio	ARB Part No.
Isuzu Trooper, Holden Jackaroo	Front	1988 on	Independent suspension (IFS)	28.4 (1.12")	17	All	RD94 ¹
	Rear	1987-91	Turbo diesel & V6 petrol only	33.5 (1.32")	26	All	RD44
		1993-97	All models	33.5 (1.32")	26	All	RD44
		1998-99 2000 on	Non-LSD models	38.1 (1.50") 38.1 (1.50")	23 23	All All	RD85 ³ NA ³
Holden Rodeo, Isuzu Pickup, Opel Campo	Front	1988 on	Independent suspension (IFS)	28.4 (1.12")	17	All	RD94 ¹
	Rear	1987-91	4x4 diesel & 4x2 diesel models	33.5 (1.32")	26	All	RD44
		1993 on	All models including 4x2	33.5 (1.32")	26	All	RD44 ⁴
Holden Suburban	Front	1998 on					NA
	Rear	1998 on	1500 petrol engine 2500 diesel engine	33.3 (1.31")	30	2.73 & UP	RD84 NA
Holden Frontera/Sport, Isuzu Rodeo/Sport, Isuzu Amigo, MU	Front	1990 on	Independent suspension (IFS)	28.4 (1.12")	17	All	RD94 ¹
	Rear	1999 on	Dana 44	33.3 (1.31")	30	4.56 & UP 4.13 & DN	RD117 ² RD117
Isuzu Axiom, Honda Passport	Front	2001 on	Independent suspension (IFS)	28.4 (1.12")	17	All	RD94
	Rear	2001 on	Dana 44	33.3 (1.31")	30	4.56 & UP 4.13 & DN	RD117 ² RD117

¹ Some builds between December 1996 and May 1998 used an unidentified 3rd member and carrier with a different ring gear bolt pattern. A 3rd member with the same ratio may be swapped from earlier or later models for Air Locker installation.

² Aftermarket Dana 44 ring and pinion ratio's of 4.56 & up will require RD116 instead.

³ Third member may be swapped from pre-2000 non-LSD model for RD85 fitment.

⁴ 2003 on models may require thrust block removal or axle shaft shortening.

NOTE: Applications for Isuzu Pickups may vary internationally. Axle model must be checked prior to purchase of Air Locker.

HYUNDAI®

Vehicle/Model	Axle Loc'n	Year	Description	Shaft Diameter	Shaft Spline	Ratio	ARB Part No.
Terracan	Front	2001 on	All models	28.8 (1.13")	28	All	RD110 ¹
	Rear	2001 on	All models		34	All	NA

¹ Air Locker fitment requires larger ring gear bolt holes. Reaming from Ø10.2mm to 12.2mm [31/64"] is required.

ARB® AIR LOCKER® MANUAL LOCKING DIFFERENTIALS

LAND ROVER® STYLE

Vehicle/Model	Axle Loc'n	Year	Description	Shaft Diameter	Shaft Spline	Ratio	ARB Part No.
Range Rover	Front	To 1993	Rover type	28.2 (1.11")	10	3.54	RD03 ^{1,4}
		1993-98	Rover type	31.5 (1.24")	24	3.54	RD56 ^{1,5}
		1998-06	Rover type, w/ traction control	31.5 (1.24")	24	3.54	RD57 ⁵
	Rear	To 1993	Rover type	28.2 (1.11")	10	3.54	RD03 ^{1,4}
		1993-98	Rover type	31.5 (1.24")	24	3.54	RD56 ^{1,5}
		1998-06	Rover type, w/ traction control	31.5 (1.24")	24	3.54	RD57 ⁵
Discovery	Front	To 1993	Rover type	28.2 (1.11")	10	3.54	RD03 ¹
		1993-98	Rover type	31.5 (1.24")	24	3.54	RD56 ^{1,5}
	Rear	To 1993	Rover type	28.2 (1.11")	10	3.54	RD03 ¹
		1993-98	Rover type	31.5 (1.24")	24	3.54	RD56 ^{1,5}
Discovery Series II	Front	All	Rover type	31.5 (1.24")	24	3.54	RD56
	Rear	All	Rover type	31.5 (1.24")	24	3.54	RD56 ⁶
		2002 on	Rover type, w/ traction control	31.5 (1.24")	24	3.54	RD57 ⁶
Discovery Series III	Front	2005 on					NA
	Rear	2005 on					NA
Defender 110, 130, County	Front	1983-93	Rover type	28.2 (1.11")	10	3.54	RD03 ¹
		1993 on	Rover type	31.5 (1.24")	24	3.54	RD56 ^{1,5}
	Rear	1983-02	Salisbury type	31.5 (1.24")	24	3.54	RD20
		2002 on	Rover type, w/ traction control	31.5 (1.24")	24	3.54	RD57 ⁶
Defender 90, County	Front	1984-93	Rover type	28.2 (1.11")	10	3.54	RD03 ¹
		1993 on	Rover type	31.5 (1.24")	24	3.54	RD56 ^{1,5}
	Rear ²	1983-93	Rover type, 4 cyl. petrol & diesel engines	28.2 (1.11")	10	3.54	RD03 ¹
		1993 on	Rover type	31.5 (1.24")	24	3.54	RD56 ^{1,5}
		2002 on	Rover type, w/ traction control	31.5 (1.24")	24	3.54	RD57 ⁶
LWB models V8 engine	Front	1979-83	Rover type	28.2 (1.11")	10	3.54	RD03
			Salisbury type	31.5 (1.24")	24	3.54	RD20
	Rear	1979-83	Salisbury type	31.5 (1.24")	24	3.54	RD20
Series III, Series II, Series I	Front	1948-85	Rover type	28.2 (1.11")	10	4.7	RD03 ^{2,3}
			Salisbury type	31.5 (1.24")	24	4.7	RD32
	Rear	1948-85	Rover type	28.2 (1.11")	10	4.7	RD03 ^{2,3}
			Salisbury type	31.5 (1.24")	24	4.7	RD32

¹ If vehicle was manufactured during 1993, check spline count.

² Air Locker not available for vehicles equipped with high load option.

³ RD03A ring gear spacer required. Longer ring gear bolts (not supplied) are also necessary - (Land Rover part no. 576521).

⁴ When an RD03 Air Locker is to be installed in Range Rovers manufactured prior to 1980 (approx.), special carrier bearings (No. K11300/K11162) may also be necessary - Land Rover part no. RTC3426.

⁵ Some vehicles have crown wheel bolts which cannot be reused and must be replaced. Consult service manual.

⁶ Some vehicles without traction control also use RD57. Identify RD57 type diff by 205mm [8.07"] flange diameter.

MAZDA® STYLE

Vehicle/Model	Axle Loc'n	Year	Description	Shaft Diameter	Shaft Spline	Ratio	ARB Part No.
Bravo (Thai)	Front	All					NA
	Rear	To 2006	2500/2600, 4 cylinder, Dana banjo type	30.8 (1.21")	30	All	RD123 ¹
BT-50 (Thai)	Rear	2006 on	6 cylinder, salisbury type	32.8 (1.29")	30	All	NA
			Dana 44,32 spline	35.8 (1.41")	32	TBD	RD143 ⁴
Navajo (US)	Front	1990-94	Dana 35	29.5 (1.16")	27	2.73-3.31	RD103
	Rear	1990-94	Ford 8.8" dia. RG, C-clip	30.5 (1.20")	28	3.54 & UP	RD102 ³
				33.5 (1.32")	31	All	RD82 ² RD81 ²
B4000, Pickup (US)	Front	1993-94	Dana 35	29.5 (1.16")	27	2.73-3.31	RD103
	Rear	1993	Ford 8.8" dia. RG, C-clip	30.5 (1.20")	28	3.54 & UP	RD102 ³
				33.5 (1.32")	31	All	RD82 ² RD81 ²

¹ Suits the shimmed type third member (not the early adjuster nut type) which can be visually identified by the Dana logo cast into the third member between the two fins of the right hand side.

² Axle spline must be determined for correct model selection.

³ See performance section of this guide for non-standard upgrade model(s) available for this application.

⁴ Available mid-2007.

ARB® AIR LOCKER® MANUAL LOCKING DIFFERENTIALS

MITSUBISHI® STYLE

Vehicle/Model	Axle Loc'n	Year	Description	Shaft Diameter	Shaft Spline	Ratio	ARB Part No.
Montero, Raider, Pajero, Delica (van)	Front	1991 on	IFS, 28 spline, 8.00" RG	28.8 (1.13")	28	All	RD110 ⁴
		1984-97	IFS, 25 spline, 7.25" RG		25	All	NA
	Rear	1983-86	8.00" 10 bolt RG ¹	30.5 (1.20")	28	All	RD05
		1987-95	9.00" 12 bolt RG ²	30.5 (1.20")	28	All	RD46 ³
		1995-02	3.5L & TDI, NK,NL, 9.5" RG, live axle	35.5 (1.40")	31	All	NA
2002 on	NM,NP, 9.5" RG, IRS		33	All	NA		
Challenger Montero Sport	Front	All	IFS, 28 spline	28.8 (1.13")	28	All	RD110
	Rear	All	3.0L, 9.00" RG	30.5 (1.20")	28	All	RD46
		All	3.5L, 9.50" RG	35.5 (1.40")	31	All	NA
Triton, Pickup	Front	All	IFS, 28 spline, 8.00" RG	28.8 (1.13")	28	All	RD110 ⁴
		All	IFS, 25 spline, 7.25" RG		25	All	NA
	Rear	All	9.00" RG	30.5 (1.20")	28	All	RD46
		2002 on	9.50" RG	35.5 (1.40")	31	All	NA

¹ Small differential has a crown wheel spigot diameter of 124mm.

² Large differential has a crown wheel spigot diameter of 145mm.

³ Will not fit turbo diesel with intercooler or 3.5L petrol vehicles.

⁴ Will not fit Pajero/Montero/Delica 3.0L automatic.

NISSAN® STYLE

Vehicle/Model	Axle Loc'n	Year	Description	Shaft Diameter	Shaft Spline	Ratio	ARB Part No.
Frontier, Xterra, Navara Pickup (D21), Wagon	Front	1986-05	R180A, 4 cyl.	27.8 (1.09")	27	All	NA
		2005-on	R200A, 6 cyl. 6 cyl.	30.4 (1.20")	29	All	RD107 ⁴ TBD
	Rear	1986 on	H233B, 31 spline, 6 cyl.	32.0 (1.26")	31	All	RD78A ^{3,4}
			H233B, 33 spline, 6 cyl.	33.3 (1.31")	33	All	RD24 ³
		2006 on	H233B, 33 spline, 12 bolt RG	33.3 (1.31")	33	All	NA
		1986-97	C200, 29 spline, 4 cyl.	30.4 (1.20")	29	All	RD107 ^{1,3,4}
		2002-05	C200, 31 spline	32.0 (1.26")	31	All	RD106 ^{3,4}
2005 on	Salisbury, 32 spline, 10 bolt RG	35.8 (1.41")	32	All	NA ⁵		
Pathfinder	Front	1986-05	R180A, 4 cyl.	27.8 (1.09")	27	All	NA
		2005 on	R200A, 6 cyl. 6 cyl.	30.4 (1.20")	29	All	RD107 ⁴ TBD
	Rear	1986-97	C200, 29 spline, 4 cyl.	30.4 (1.20")	29	All	RD107 ^{1,3,4}
		1986-05	H233B, 31 spline, 6 cyl.	32.0 (1.26")	31	All	RD78A ^{3,4}
		2005 on	33 spline, 12 bolt RG	33.3 (1.31")	33	All	NA ⁵
Y61, Patrol GU	Front	1998 on	H233B	32.0 (1.26")	31	All	RD78A ⁴
	Rear	1998 on	H233B 'small'	33.3 (1.31")	33	All	RD24 ³
		1998 on	H260 'large', 37 spline H260 'large', 34 spline	38.4 (1.51")	37 34	All	RD70 ^{3,4} NA ^{2,3}
Y60, Patrol GQ	Front	1988-98	H233B, 31 SPL	32.0 (1.26")	31	All	RD78A ⁴
	Rear	1988-98	H233B, 33 SPL	33.3 (1.31")	33	All	RD24
		1988-98	H260, leaf sprung cab chassis & utility	38.4 (1.51")	37	All	RD70 ⁴
160, Patrol MQ	Front	1979-88	C200	30.4 (1.20")	29	All	RD107 ⁴
	Rear ³	1979-88	C200	30.4 (1.20")	29	All	RD107 ⁴
		1979-88	H233	32.0 (1.26")	31	All	RD04
		1979-88	H260	38.4 (1.51")	37	All	RD70 ⁴
Terrano II Wagon	Rear	1997 on	H233B	32.0 (1.26")	31	All	RD78A ^{3,4}
		2003 on	H233B	33.3 (1.31")	33	All	RD24 ³
Titan	Front	2004 on	TBD				TBD
	Rear	2004 on	Salisbury, 32 spline, 10 bolt RG	35.8 (1.41")	32	All	NA ⁵

¹ Only suitable for differentials with 12mm crown wheel bolts.

² No application for leaf sprung cab chassis vehicles with 34 spline axle shafts.

³ Refer to dealer or check spline count to determine axle type.

⁴ Floating thrust block(s) are included but should ONLY be installed on semi-floating axle assemblies. Refer to installation guide.

⁵ Available mid to late 2007.

ARB® AIR LOCKER® MANUAL LOCKING DIFFERENTIALS

SANTANA® STYLE

Vehicle/Model	Axle Loc'n	Year	Description	Shaft Diameter	Shaft Spline	Ratio	ARB Part No.
Anibal, PS10	Front		All models (Land Rover type)		10	All	RD03 ¹
	Rear		All models		24	All	RD126
PS300	Front		10 bolt RG (Suzuki Vitara type)	27.4 (1.08")	26	All	RD88
	Rear		12 bolt RG	27.4 (1.08")	26	All	NA ²
PS350	Front		10 bolt RG (Suzuki Vitara type)	27.4 (1.08")	26	All	RD88 ²
	Rear		12 bolt RG	27.4 (1.08")	26	All	NA ²

¹ Requires ring gear spacer (ARB part # RD03A) ordered separately.

² Requires 10 bolt RD88 conversion using PS300 front third member assembly of same ratio.

SsangYong® STYLE

Vehicle/Model	Axle Loc'n	Year	Description	Shaft Diameter	Shaft Spline	Ratio	ARB Part No.
Musso / Rexton / Korando	Front	1996 on	Dana 30, live axle	29.5 (1.16")	27	3.73 & UP	RD100 ¹
	Rear	1996 on	Dana 44, manual	33.3 (1.31")	30	4.55	RD116 ¹
		1996 on	Dana 44, automatic	33.3 (1.31")	30	3.73	RD117

¹ See performance section of this guide for non-standard upgrade model(s) available for this application.

SUZUKI® STYLE

Vehicle/Model	Axle Loc'n	Year	Description	Shaft Diameter	Shaft Spline	Ratio	ARB Part No.
Sierra / Samurai / Jimny Holden Drover Maranti Gypsy	Front	2003 on	Jimny model with 10 bolt RG	23.9 (0.94")	22	All	RD118
		1998-03	Jimny model with 8 bolt RG	23.9 (0.94")	22	All	RD87
	Rear	1984-98	Leaf spring suspension	23.9 (0.94")	22	All	RD75
		1984 on	1.3 litre models only	27.4 (1.08")	26	All	RD88
Jimny (Japan only) (JA11, JA12)	Front	1990-95	JA11, 660cc turbocharged engines ONLY	23.9 (0.94")	22	All	RD87
	Rear	1990-98	JA11 & JA12, 660cc turbocharged engines	27.4 (1.08")	26	All	RD88
Vitara / Sidekick Grand Vitara, XL7	Front	1988-98	26 spline	27.4 (1.08")	26	All	RD88
			22 spline	23.9 (0.94")	22	All	RD75
		1998-05	26 spline ADD	27.4 (1.08")	26	All	NA ²
			2005 on				All
	Rear	1988-93	Suzuki 10 bolt RG	27.4 (1.08")	26	All	RD74 ¹
		1993-00	Suzuki 12 bolt RG	27.4 (1.08")	26	All	RD79 ¹
		1998-05	26 spline	27.4 (1.08")	26	All	NA ³
2005 on	28 spline IRS	28.8 (1.13")	28	All	NA		

¹ Note that in some (Asian) countries, the Dana 30 salisbury type axle was used from 1993 on. See RD100 & RD101.

² Grand Vitara/XL7 (to 2005) front requires conversion using RD88, Vitara/Sidekick third member assembly and free wheeling hubs.

³ Grand Vitara/XL7 (to 2005) rear requires conversion using Vitara/Sidekick third member assembly (and 26 spl axle shafts if required). No application for current model (2005 on) Grand Vitara.

MotiveGear
Performance®

ARB® AIR LOCKER® MANUAL LOCKING DIFFERENTIALS

TOYOTA® / LEXUS® STYLE

Vehicle/Model	Axle Loc'n	Year	Description	Shaft Diameter	Shaft Spline	Ratio	ARB Part No.
LandCruiser 78, 79, 100 & 105 Series	Front	1998 on	8" dia. RG, IFS, 50mm bearing ID	33 (1.31")	30	All	RD92
		1998 on	Live axle suspension	33 (1.31")	30	All	RD23
Lexus LX470	Rear	1998 on	All models	34.8 (1.37")	32	All	RD64
LandCruiser 40, 55, 60, 62, 75, & 80 Series Lexus LX450	Front	To 1989	12 bolt, full floating	33 (1.31")	30	All	RD33 ¹
		1990-97	10 bolt, full floating	33 (1.31")	30	All	RD23
		1969-76	12 bolt, semi floating	33 (1.31")	30	All	RD124 ¹
	Rear	1977-89	12 bolt, full floating, 45mm bearing ID	33 (1.31")	30	All	RD33 ¹
		1990-97	12 bolt, full floating, 50mm bearing ID	33 (1.31")	30	All	RD33
		1977-92	12 bolt, semi floating	33 (1.31")	30	All	RD124
FJ40s made in South America	Rear		Dana 60	30 (1.31")	30	4.56 & UP 4.10 & DN	RD21 RD22
Bundera, LandCruiser II LJ70, RJ70	Front	All	10 bolt	33 (1.31")	30	All	RD23 ¹
	Rear	To 1985	10 bolt, 45mm bearing ID	33 (1.31")	30	All	RD23 ¹
		1986 on	10 bolt, 50mm bearing ID	33 (1.31")	30	All	RD23
HiLux, Pickup	Front	All	10 bolt, live axle	33 (1.31")	30	All	RD23 ¹
		To 2005	7.5" dia. RG, 10 bolt, IFS	28 (1.1")	27	All	RD90 ²
		2005 on	8" dia. RG, IFS clamshell, 53mm BRNG	33 (1.31")	30	3.91 & UP 3.73 & DN	RD111 ³ RD121 ³
	Rear	To 1988	4 cylinder, 45mm bearing ID	33 (1.31")	30	All	RD23 ¹
		1988-05	All models, 50mm bearing ID	33 (1.31")	30	All	RD23
		2005 on	Adjuster nut models, 50 or 53mm bearing ID Dana Spicer shim adjusted models.	33 (1.31")	30	All	RD23 ⁴ RD133 ⁵
4Runner, LN61, YN63	Front	All	10 bolt, live axle	33 (1.31")	30	All	RD23 ¹
		To 2003	7.5" dia. RG, 10 bolt, IFS	28 (1.1")	27	All	RD90 ²
		2003 on	8" dia. RG, IFS clamshell, 53mm BRNG	33 (1.31")	30	3.91 & UP 3.73 & DN	RD111 ³ RD121 ³
	Rear	1984-88	4 cylinder, 45mm bearing ID	33 (1.31")	30	All	RD23 ¹
		1988 on	V6, 4WD, 50mm bearing ID	33 (1.31")	30	All	RD23
		1988 on	V6, 2WD, 45mm bearing ID	33 (1.31")	30	All	RD23 ¹
LandCruiser Prado, LandCruiser 120 Series, Lexus GX	Front	1996-03	7.5" dia. RG, 10 bolt, IFS	28 (1.1")	27	All	RD90
		2003 on	8" dia. RG, IFS clamshell, 53mm BRNG	33 (1.31")	30	3.91 & UP 3.73 & DN	RD111 ³ RD121 ³
	Rear	1996 on	8" dia. RG, 10 bolt	33 (1.31")	30	All	RD23
T100, Tacoma	Front	2004 on	8" dia. RG, IFS clamshell, 53mm BRNG	33 (1.31")	30	3.91 & UP 3.73 & DN	RD111 ³ RD121 ³
		To 2004	7.5" dia. RG, 10 bolt, IFS	28 (1.1")	27	All	RD90
	Rear	All	8" dia. RG, 12 bolt	33 (1.31")	30	All	RD89
Tundra	Front	2007 on	TBD		34		TBD
		2005-07	8" dia. RG, IFS clamshell, 53mm BRNG	33 (1.31")	30	3.91 & UP 3.73 & DN	RD111 ³ RD121 ³
	Rear	To 2004	7.5" dia. RG, 10 bolt, IFS	28 (1.1")	27	All	RD90
		2007 on	TBD		36		TBD
FJ Cruiser (US)	Front	2005 on	8" dia. RG, IFS clamshell, 53mm BRNG	33 (1.31")	30	3.91 & UP 3.73 & DN	RD111 ³ RD121 ³
		2005 on	8" non-factory locker model	33 (1.31")	30	All	RD23

¹ Late model 50.00mm [1.969"] ID carrier bearings (e.g., from FJ/HJ80 model) must be used. This will also improve bearing life.

² Does not fit some 1986-1995 manual hub models with larger 33mm [1.30"] dia. 27 spline axle shafts.

³ May use either RD111 or RD121. Model required varies with R&P ratio used.

⁴ Some models have 53mm bearing ID and require new carrier bearings (Koyo #TR100802-2 from LC100 IFS carrier).

⁵ Shim adjusted Dana Spicer made models came in some vehicles from South Africa.

PERFORMANCE STYLE APPLICATIONS®

Description	Ratio	Notes	Spline Count	Shaft Diameter	Spline Type	Pressure Angle	ARB Part No.
Ford 9"	ALL	Does not suit OE third member	35	38.1 (1.50")	24/48 DP	30°	RD99 ¹
Dana 30	3.73 & UP		30	33.3 (1.31")	24/48 DP	30°	RD104
Dana 35	3.54 & UP	Suits C-clip or non-C-clip type shafts	30	33.3 (1.31")	24/48 DP	30°	RD105
Dana 35	3.54 & UP	Suits ONLY non-C-clip retained shafts (4 pinion)	30	33.3 (1.31")	24/48 DP	30°	RD125
Dana 44	3.92 & UP		35	38.1 (1.50")	24/48 DP	30°	RD109
Dana 44	3.92 & UP		33	34.8 (1.37")	24/48 DP	45°	RD113
Dana 70	4.56 & UP		37	40.6 (1.60")	24/48 DP	45°	RD115

NOTE: Performance application models do not suite any original equipment axle shafts.

Custom shafts to suit your specific axle assembly must be obtained.

Contact ARB for more information on performance upgrades available to suit your axle type.

¹ Can be manually modified to accept 33 spline axle shafts. Contact ARB.

RD99 will suit Ford 9 3/8" third member if alternative ARB adjuster nut is used.

ARB® AIR LOCKER® MANUAL LOCKING DIFFERENTIALS

APPLICATIONS BY PART NUMBER

ARB Part No.	Description	Splines	Ratio
RDCKA	On-Board Air Compressor Kit,Medium		
RDCKA24	On-Board Air Compressor Kit,Medium (24 VOLT)		
RDCP	Portable Air Compressor,Deluxe (includes pressure cutout & tyre pressure gauge)		
RDCPA	Portable Air Compressor		
CKSA12	On-Board Air Compressor Kit,Small		
ARB Part No.	Description	Splines	Ratio
RD03	Land Rover,10 SPL, Banjo	10	3.54
RD04	Nissan,H233,31 SPL	31	All
RD05	Mitsubishi 8",RR,28 SPL	28	All
RD09	Nissan H233B,31 SPL (thrust block only)	31	All
RD12	GM 12 Bolt,8.9",30 SPL,3.73 & UP	30	3.73 & UP
RD17	Nissan H233B,33 SPL (disc brake only)	33	All
RD20	Land Rover,Salisbury,3.54:1	24	3.54
RD21	Dana 60,30 SPL,4.56 & UP	30	4.56 & UP
RD22	Dana 60,30 SPL,4.10 & DN	30	4.10 & DN
RD23	Toyota 8",50mm BRNG	30	All
RD24	Nissan H233B,33 SPL	33	All
RD25	Mitsubishi 9",RR,28 SPL (disc brake only)	28	All
RD32	Land Rover,Salisbury,4.70:1	24	4.7
RD33	Toyota 8.9",50mm BRNG	30	All
RD35	Dana 60HD,35 SPL,4.56 & UP	35	4.56 & UP
RD36	Dana 60HD,35 SPL,4.10 & DN	35	4.10 & DN
RD37	Ford 10.25" & 10.5" (Sterling / corporate)	35	All
RD40	GM 14 Bolt,9.5",C-clip	33	All
RD42	Dana 60HD,C-clip,35 SPL,4.56 & UP	35	4.56 & UP
RD43	Dana 60HD,C-clip,35 SPL,4.10 & DN	35	4.10 & DN
RD44	Isuzu,RR,26 SPL	26	All
RD46	Mitsubishi 9",RR,28 SPL	28	All
RD47	AMC Model 20,2.73:1	29	2.73
RD50	Dana 50,30 SPL	30	All
RD51	GM / AAM 9.25",33 SPL	33	All
RD53	Dana 70HD,35 SPL,4.56 & UP	35	4.56 & UP
RD54	Dana 70HD,35 SPL,4.10 & DN	35	4.10 & DN
RD56	Land Rover,24 SPL, Banjo	24	All
RD57	Land Rover,24 SPL, Banjo, T/C	24	All
RD60	AMC Model 20,3.08 & UP	29	3.08 & UP
RD64	Toyota 9.5",32 SPL	32	All
RD65	Dana 70U,35 SPL,4.56 & UP	35	4.56 & UP
RD66	Dana 70U,35 SPL,4.10 & DN	35	4.10 & DN
RD70	Nissan H260,37 SPL	37	All
RD71	Nissan H260,37 SPL (disc brake only)	37	All
RD74	Suzuki Vitara,RR,26 SPL,10 bolt RG	26	All
RD75	Suzuki,FR,22 SPL,10 bolt RG	22	All
RD78A	Nissan H233B,31 SPL	31	All
RD79	Suzuki Vitara,RR,26 SPL,12 bolt RG	26	All
RD80	Dana 80,35 SPL	35	Varies by Mfg.
RD81	Ford 8.8",31 SPL	31	All
RD82	Ford 8.8",28 SPL	28	All
RD83	GM 10 Bolt,28 SPL,8.5"	28	2.73 & UP
RD84	GM 10 Bolt,30 SPL,8.5"	30	2.73 & UP
RD85	Isuzu RR,23 SPL,non-LSD	23	All
RD87	Suzuki Jimny,FR,22 SPL,8 bolt RG	22	All
RD88	Suzuki,26 SPL,10 bolt RG	26	All
RD89	Toyota Tacoma,RR	30	All
RD90	Toyota 7.5" IFS	27	All
RD91	Dana 80,37 SPL	37	Varies by Mfg.
RD92	Toyota 8" IFS,50mm BRNG	30	All
RD93	Chrysler 8.25",29 SPL	29	All
RD94	Isuzu IFS,17 SPL	17	All
RD95	Dana 60,32 SPL,4.56 & UP	32	4.56 & UP
RD96	Dana 60,32 SPL,4.10 & DN	32	4.10 & DN
RD97	Dana 70,32 SPL,4.56 & UP	32	4.56 & UP
RD98	Dana 70,32 SPL,4.10 & DN	32	4.10 & DN
RD99	Ford 9",35 SPL,2" BRNG	35	All
RD100	Dana 30,27 SPL,3.73 & UP	27	3.73 & UP
RD101	Dana 30,27 SPL,3.54 & DN	27	3.54 & DN
RD102	Dana 35,27 SPL,3.54 & UP	27	3.54 & UP
RD103	Dana 35,27 SPL,3.31 & DN	27	3.31 & DN
RD104	Dana 30,30 SPL,3.73 & UP	30	3.73 & UP
RD105	Dana 35,30 SPL,3.54 & UP	30	3.54 & UP
RD106	Nissan C200,31 SPL	31	All
RD107	Nissan C200/R200A,29 SPL	29	All
RD109	Dana 44,35 SPL,3.92 & UP	35	3.92 & UP
RD110	Mitsubishi IFS,28 SPL	28	All
RD111	Toyota 8" IFS,53mm BRNG	30	3.91 & UP
RD112	Chrysler 8.25",27 SPL	27	All
RD113	Dana 44,33 SPL,3.92 & UP	33	3.92 & UP
RD114	GM 14 Bolt,10.5",FF	30	4.10 & DN
RD115	Dana 70HD,37 SPL,4.56 & UP	37	4.56 & UP
RD116	Dana 44,30 SPL,3.92 & UP	30	3.92 & UP
RD117	Dana 44,30 SPL,3.73 & DN	30	3.73 & DN
RD118	Suzuki Jimny,FR,22 SPL,10 bolt RG	22	All
RD119	Ford 9",31 SPL	31	All
RD121	Toyota 8" IFS,53mm BRNG	30	3.73 & DN
RD123	Mazda,RR,shim adjusted	30	All
RD124	Toyota 8.9",C-clip,50mm BRNG	30	All
RD125	Dana 35,non C-clip,30 SPL,3.54 & UP	30	3.54 & UP
RD126	Santana Anibal,RR	24	All
RD143	Courier, Ranger, Dana 44	32	TBD

GENERAL NOTES

While every effort has been made to ensure that this list is accurate, ARB Corporation Ltd cannot possibly guarantee its accuracy or completeness given the large number of vehicle makes, models, and option variations, and therefore it is the client's responsibility to establish the correct model Air Locker for their application.

While ARB supplies Air Lockers for the front of many vehicles, they should only be engaged for off-highway use only.

'TBD' refers to information that is still yet 'to be determined' at this time.

'& UP' following the ratio means that the Air Locker is suitable for the stated ratio and those which are numerically higher.

'& DN' following the ratio means that the Air Locker is suitable for the stated ratio and those which are numerically lower.

'RG' refers to the 'ring gear' or 'brown wheel' of the vehicle.

'dia RG' refers to the outside diameter taken over the outside of the ring gear teeth.

'SPL' refers to the spline of the axle shaft.

'FR' refers to front axle application.

'RR' refers to rear axle application.

'IFS' refers to independent front suspension.

'BRNG' refers to carrier bearing inside diameter.

'LSD' refers to vehicles originally equipped with a Limited Slip Differential.

'Year xxxx on' refers to model years up to the revision date of this printing of the chart.

Only the first Air Locker installation in a vehicle requires a compressor kit. The second unit in the same vehicle utilises the same compressor installed for the first unit.

AUBURN GEAR® ASSEMBLIES



AMC® STYLE

AG PART#	SIZE	APPLICATIONS	RATIOS	SIDE GEAR SPLINE	MODEL YEARS
542081*	AMC® 20, 12 Bolt	All AMC® 20 Axles	3.07 - UP	29 Teeth	1966 -1986

DANA® STYLE

*PRO SERIES

AG PART#	SIZE	APPLICATIONS	RATIOS	SIDE GEAR SPLINE	MODEL YEARS
5420109	Model 44	All Dana® 44 models without "C" clips	3.92 -UP	30 Teeth	1971-Present
5420110	Model 44	All Dana® 44 models without "C" clips	3.73 -DN	30 Teeth	1971-Present
542082*	Model 44	All Dana® 44 models without "C" clips	3.92 -UP	30 Teeth	1971-Present
542083*	Model 44	All Dana® 44 models without "C" clips	3.73 -DN	30 Teeth	1971-Present
542084*	Model 44	All Dana® 44 models without "C" clips	3.92 -UP	19 Teeth	1970 & Prior
542085*	Model 44	All Dana® 44 models without "C" clips	3.73 -DN	19 Teeth	1970 & Prior
5420111	Model 44	All Dana® 44 models without "C" clips	3.92 -UP	19 Teeth	1970 & Prior
5420112	Model 44	All Dana® 44 models without "C" clips	3.73 -DN	19 Teeth	1970 & Prior

DODGE®/ CHRYSLER® STYLE

*PRO SERIES

542072	8-1/4, 10 Bolt	All Chrysler® products w/ 8-1/4" & 8-3/8" ring gear (Accepts tone ring for ABS applications)	2.71-UP	27 Teeth	1966 -1996
542074	8-1/4, 10 Bolt	All Chrysler® products w/ 8-1/4" & 8-3/8" ring gear (Accepts tone ring for ABS applications)	2.71-UP	29 Teeth	1997-Present
542004	8-1/2		2.24-2.45		
542051*	8-3/4, 10 Bolt	All Chrysler® products with 8 3/4" ring gear	All Ratios	30 Teeth	1957-1974
542070	9-1/4, 12 Bolt	All Chrysler® products w/9-1/4" ring gear (Accepts tone ring for ABS applications)	2.71-UP	31 Teeth	1984-Present
542071	9-1/4, 12 Bolt	All Chrysler® products with 9-1/4" ring gear	2.71-UP	31 Teeth	1968-1983

ECTED® STYLE

ECTED® stands for Electronically Controlled Traction Enhancing Differential

■ 545006	AMC® 20	All AMC® 20 axles including H1 Hummer	2.73 - DN	29 Teeth	1966 -ON
■ 545007	AMC® 20	All AMC® 20 axles including H1 Hummer	3.07 - DN	29 Teeth	1966 -1986
■ 545016	Model 30	All Dana® 30 applications - Jeep®, Ford®, Toyota®	3.55 - DN	27 Teeth	1967-ON
■ 545017	Model 30	All Dana® 30 applications - Jeep®, Ford®, Toyota®	3.73 - UP	27 Teeth	1967-ON
■ 545012**	Model 35	All Dana® 35 applications - Jeep®, Ford®, Mazda®	3.31 - DN	27 Teeth	1987-ON
■ 545013**	Model 35	All Dana® 35 applications - Jeep®, Ford®, Mazda®	3.55 - UP	27 Teeth	1987-ON
■ 545014**	Model 35	All Dana® 35 applications - Jeep®, Ford®, Mazda®	3.31 - DN	30 Teeth***	1987-ON

** Does not use stock bearings. Use LM102949, LM102911 carrier bearings.

*** 30 Teeth requires aftermarket axle shafts.

AUBURN GEAR® ASSEMBLIES

ECTED® (CONT.)

ECTED® stands for Electronically Controlled Traction Enhancing Differential

AG PART#	SIZE	APPLICATIONS	RATIOS	SIDE GEAR SPLINE	MODEL YEARS
■ 545015**	Model 35	All Dana® 35 applications -Jeep®,Ford®,Mazda®	3.55 - UP	30 Teeth***	1987-ON
■ 545018	Model 44	All Dana® 44 applications w/o C-Clip	3.73 -DN	30 Teeth	1971-ON
■ 545019	Model 44	All Dana® 44 applications w/o C-Clip	3.92 -UP	30 Teeth	1971-ON
■ 545020	Model 50	All Dana® 50 applications - F250, F350, Ford® Excursion - Front Axles	All Ratios	30 Teeth	1981-2004 2000-2005
545003	8.5 & 8.6, 10 Bolt	All GM® products with 8.5" & 8.6" ring gear	2.73 -UP	28 Teeth	1971-1988
545004	8.5 & 8.6, 10 Bolt	All GM® products with 8.5" & 8.6" ring gear	2.73 -UP	30 Teeth	1989-Present
■ 545009	8.875, 12 Bolt	All Chevrolet® Truck w/12 Bolt 3 Series Case	2.76 -3.42	30 Teeth	1964-1982-1/2
■ 545011	8.875, 12 Bolt	All Chevrolet® Truck w/12 Bolt 3 Series Case	3.73 -UP	30 Teeth	1964-1982-1/2
545001	8.8, 10 Bolt	All Ford® products with 8.8" ring gear Accepts tone ring for ABS applications	All Ratios	28 Teeth	1979-Present
545002	8.8, 10 Bolt	All Ford® products with 8.8" ring gear Accepts tone ring for ABS applications	All Ratios	31 Teeth	1983-Present
545005	8.8, 10 Bolt	All Ford® products with 8.8" ring gear Accepts tone ring for ABS applications For IRS applications only	All Ratios	31 Teeth	1983-Present

FORD®

*PRO SERIES

542023	7-1/2, 10 Bolt	All Ford® products with 7.5" ring gear (Accepts tone ring for ABS applications)	All Ratios	28 Teeth	1978 -Present
542048*	7-1/2, 10 Bolt	All Ford® products with 7-1/2" ring gear (Accepts tone ring for ABS applications)	All Ratios	28 Teeth	1978 -Present
5420115*	7-3/4 & 8, 10 Bolt	All Ford® products with 7-3/4" & 8" ring gear (Use Ford® D80Z4216B ring gear bolts)	All Ratios	28 Teeth	1960-1979
542059*	8, 10 Bolt	All Ford® products with 7-3/4" & 8" ring gear (Use Ford® D80Z4216B ring gear bolts)	All Ratios	28 Teeth	1960-1979
5420116*	8.8	All Ford® products with 8.8" ring gear (Accepts tone ring for ABS applications)	All Ratios	31 Teeth	1983-Present
542025	8.8, 10 Bolt	All Ford® products with 8.8" ring gear 31 spl.	All Ratios	31 Teeth	1983-Present
542039	8.8, 10 Bolt	All Ford® products with 8.8" ring gear (Accepts tone ring for ABS applications)	All Ratios	28 Teeth	1979-Present
542054*	8.8	All Ford® products with 8.8" ring gear 31 spl. (Accepts tone ring for ABS applications)	All Ratios	31 Teeth	1983-Present
542080*	8.8, 10 Bolt	All Ford® products with 8.8" ring gear, including IRS applications (Accepts tone ring for ABS applications)	All Ratios	28 Teeth	1979-Present
542079	8.8, 10 Bolt	All Ford® products with 8.8" ring gear (Accepts tone ring for ABS applications)	All Ratios	28 Teeth	1979-Present
542036*	9, 10 Bolt	All Ford® products with 8-3/4" & 9" ring gear (Use Ford® D80Z4216B ring gear bolts)	All Ratios	31 Teeth	1957-1987
542043*	9, 10 Bolt	All Ford® products with 8-3/4" & 9" ring gear (Use Ford® D80Z4216B ring gear bolts)	All Ratios	28 Teeth	1957-1987
542090	9-3/4, 12 Bolt	All Ford® products with 9-3/4" ring gear (Accepts tone ring for ABS applications)	All Ratios	34 Teeth	1997-Present
542089	10-1/4 & 10-1/2, 12 Bolt	All Ford® products with 10-1/4" & 10-1/2" ring (Accepts tone ring for ABS applications)	All Ratios	35 Teeth	1983-Present

PRO FORD® 8" & 9" MODELS USE D80Z4216B RG BOLTS

NOTE: AUBURN® SERVICE PARTS AVAILABLE - PLEASE CALL FOR PRICING AND AVAILABILITY.

AUBURN GEAR® ASSEMBLIES

GENERAL MOTORS® STYLE

AG PART#	SIZE	APPLICATIONS	RATIOS	SIDE GEAR SPLINE	MODEL YEARS
*PRO SERIES					
542040	7-1/2 & 7-5/8, 10 Bolt	All GM® products w/7-1/2 & 7-5/8 ring gear (Accepts tone ring for ABS applications)	3.23 - UP	28 Teeth	1988-Present
542041	7-1/2 & 7-5/8, 10 Bolt	All GM® products w/7-1/2 & 7-5/8 ring gear (Accepts Tone ring for ABS applications)	3.08 - DN	28 Teeth	1988-Present
542044*	7-1/2 & 7-5/8, 10 Bolt	All GM® products with 7-1/2 & 7-5/8 ring gear	3.23 - UP	26 Teeth	1976-1988
542045*	7-1/2 & 7-5/8, 10 Bolt	All GM® products with 7-1/2 & 7-5/8 ring gear	3.08 - DN	26 Teeth	1976-1988
542046*	7-1/2 & 7-5/8, 10 Bolt	All GM® products with 7-1/2 & 7-5/8 ring gear (Accepts tone ring for ABS applications)	3.23 - UP	28 Teeth	1988-Present
542047*	7-1/2 & 7-5/8, 10 Bolt	All GM® products with 7-1/2 & 7-5/8 ring gear (Accepts tone ring for ABS applications)	3.08 - DN	28 Teeth	1988-Present
542057	7-1/2 & 7-5/8, 10 Bolt	All GM® products w/7-1/2 & 7-5/8 ring gear	3.23 - UP	26 Teeth	1976-1988
542058	7-1/2 & 7-5/8, 10 Bolt	All GM® products w/7-1/2 & 7-5/8 ring gear	3.08 - DN	26 Teeth	1976-1988
542088	7-1/2 & 7-5/8	All GM® products w/7-1/2 & 7 5/8 ring gear	3.23 - UP	28 Teeth	1988-Present
542060*	8.2, 10 Bolt	Buick®, Oldsmobile®, Pontiac® with 8.2 ring gear, Non "C" lock axle, 27 tooth pinion spline	3.36 - UP	28 Teeth	1964-1971
542061*	8.2, 10 Bolt	Chevrolet® with 8.2 ring gear, "C" lock axle, 25 tooth pinion spline	3.08 - UP	28 Teeth	1964-1972
5420108	8.2, 10 Bolt	Chevrolet® w/8.2" ring gear, "C" lock axle, 25 tooth pinion spline	3.08 - UP	28 teeth	1964-1972
5420113	8.2	Buick®, Olds®, Pontiac® with 8.2 ring gear	3.36 - UP	28 Teeth	1964-1971
5420114	8.2	Buick®, Olds®, Pontiac® with 8.2 ring gear	2.93-3.23	28 Teeth	1964-1971
542099*	8.2	Olds® & Pontiac®	2.93 - 3.23	28 Teeth	1964-1971
5420100	8.4	AG-GM® 8.4 10 Bolt	4.70 - DN		1955-1964
542062*	8.5, 10 Bolt	Corvette®	2.41 - 3.70	17 Teeth	1963-1979
542063*	8.5, 10 Bolt	Corvette®	4.10 - UP	17 Teeth	1963-1979
542018	8.5 & 8.6, 10 Bolt	All GM® products w/8.5 & 8.6 ring gear	2.73 - UP	28 Teeth	1971-1988
542022	8.5 & 8.6, 10 Bolt	All GM® products w/8.5 & 8.6 ring gear	2.73 - UP	30 Teeth	1989-1998
542029	8.5 & 8.6, 10 Bolt	All GM® products w/8.5 & 8.6 ring gear	2.56 - DN	30 Teeth	1989-1998
542050*	8.5 & 8.6, 10 Bolt	All GM® products with 8.5 & 8.6 ring gear (Large bearing hub, includes bearings)	2.73 - UP	28 Teeth	1971-1988
542052*	8.5 & 8.6, 10 Bolt	All GM® products with 8.5 & 8.6 ring gear (Large bearing hub, includes bearings)	2.73 - UP	30 Teeth	1989-Present
542097	8.5 & 8.6, 10 Bolt	All GM® products w/8.5 & 8.6 ring gear (Uses LM60349 & LM60312 diff. bearings)	2.73 - UP	30 Teeth	1999-Present
542031*	8-7/8, 12 Bolt	Chevrolet® passenger car w/8-7/8 ring gear ("C" axle 4 series case)	4.10 - UP	30 Teeth	1965-1972
542033*	8-7/8, 12 Bolt	Chevrolet® passenger car w/8-7/8 ring gear ("C" axle 3 series case)	3.07 - 3.73	30 Teeth	1965-1972
542032*	8-7/8, 12 Bolt	Chevrolet® truck with 8-7/8 ring gear (4 series case)	3.73 - UP	30 Teeth	1964-1982-1/2
542034*	8-7/8, 12 Bolt	Chevrolet® truck with 8-7/8 ring gear (3 series case)	2.76 - 3.42	30 Teeth	1964-1982-1/2
5420104	8-7/8	AG-GM®	4.10 - UP	30 Teeth	1965-1972
5420105	8-7/8	Truck	3.73 - UP	30 Teeth	1964-1982
5420106	8-7/8	GM®	3.07 - 3.73	30 Teeth	1965-1972
5420107	8-7/8	AG-GM® Truck	2.76 - 3.42	30 Teeth	1964-1982
5420117*	8-7/8", 12 Bolt	GM® Car		33 Teeth	1964-1972
5420118	8-7/8", 12 Bolt	GM® Car		33 Teeth	1965-1972
542087	9.5, 14 Bolt	All GM® products with 9-1/2 ring gear	All Ratios	33 Teeth	1984-Present
542030*	8-7/8, 12 Bolt	Landcruiser (1967 & prior must update to 30 tooth axle shafts)	All Ratios	30 Teeth	1968-1989

DOMINATE THE TRAIL

TOYOTA®

<u>AG REF PART#</u>	<u>SIZE</u>	<u>APPLICATIONS</u>	<u>RATIOS</u>	<u>SIDE GEAR SPLINE</u>	<u>MODEL YEARS</u>
542030*	8-7/8, 12 Bolt	Landcruiser® (1967 & prior must update to 30 tooth axle shafts)	All Ratios	30 Teeth	1968-1989



LIGHT TRUCK & PERFORMANCE CAR APPLICATION GUIDE



Posi™

- Carbon Friction Technology
- Precision-Forged Gears
- Automatic LSD
- Rebuildable



ELocker™

- Push Button
- Maintenance Free
- Driver Controlled
- Servicable



Detroit Locker™

- 100% Automatic Locking
- Wheel Speed Sensitive
- Legendary Traction
- Unmatched Durability



Detroit Truetrac™

- Helical Gear LSD
- Torque Biasing
- Smooth & Automatic
- Improved Design



Detroit E-Z Locker™

- E-Z on the Budget
- E-Z to Install
- E-Z on the Trails
- E-Z Locking Action

	Year	Description	Axle Shaft Dia.-Spline	Ring Gear Pinion Ratio	Detroit Locker	Detroit Truetrac	Detroit E-Z Locker	Eaton Posi	Eaton ELocker	
REAR	CHEVROLET/GMC									
	Camaro • Chevelle • Corvette • Grand National • Nova • Car									
		1964-72	GM 12 bolt car	8.875"	1.29" 30	3.08-3.90	187C197A	913A555 (pa)	19554-010	
		1964-72	GM 12 bolt car	8.875"	1.29 30	4.10 & up			19555-010	
		1964-72	GM 12 bolt car	8.875"	1.41" 33	3.08-3.90	187C198A	914A576 (pa)		
		1964-72	GM 12 bolt car	8.875"	1.41" 33	4.10 & up		914A575 (pa)		
			GM 12 bolt car	8.875"	1.50" 35	3.08-3.90	187S196A (ch)			
		1955-64	GM 3rd member	8.2"	17	3.90 & dn			19686-010	
		1963-79	GM 10 bolt Corvette	8.5"	17	3.08-3.90			19670-010	
			(cast iron 3rd member)		17	4.11-4.56			19673-010	
		1988-96	GM 10 bolt C-Clip	8.5/8.6"	1.32" 30	2.73 & up	187C148A	913A481	813A023	19559-010
		1971-89	GM 10 bolt C-Clip	8.5"	1.20" 28	2.73 & up	187C149A	912A556	813A022	19557-010
		1964-71	GM 10 bolt Buick, Olds, Pontiac	8.2"	28	3.36 & up				19674-010
		1964-72	GM 10 bolt Chevrolet	8.2"	28	3.08 & up				19603-010
		1988-05	GM 10 bolt	7.5/7.6"	1.20" 28	3.23 & up	162C59A	912A317		19599-010
		1975-89	GM 10 bolt C-Clip	7.5"	1.16" 26	3.23 & up	162C58A	911A319		19663-010
					3.08 & dn		911A415			
	(ch) custom housing with 3.25" bearing bore.									
	(pa) 30 and 33 spline units are made to fit axles cut with 45 degree pressure angle.									
FRONT	10/1500 • Pickup • Blazer/Jimmy • Suburban • Tahoe • Yukon • Van									
		1977-88	GM 10 bolt	8.5"	1.20" 28	2.73-5.13	187C149A	912A557	813A022	19557-010
		To 1990	Dana 44	8.5"	1.31" 30	3.73 & dn	187SL16D	913A591	813A014	19695-010
						3.92 & up	187SL16C	913A592	813A014	19747-010
		1988-05	GM 10 bolt	7.5/7.6"	1.20" 28	3.23 & up	162C59A	912A317		19599-010
		1982-89	GM 10 bolt C-Clip	7.5"	1.16" 26	3.23 & up	162C58A	911A319		19663-010
						3.08 & dn		911A415		
		1989-06	GM 10 bolt C-Clip	8.5/8.6"	1.32" 30	2.73 & up	187C148A	913A481	813A023	19559-010
		1972-88	GM 10 bolt C-Clip	8.5"	1.20" 28	2.73 & up	187C149A	912A556	813A022	19557-010
		To 1982	GM 12 bolt C-Clip	8.875"	1.30" 30	3.73 & up	187C150A	913A315	813A013	19556-010
					2.76-3.42				19587-010	
All GM 8.5"/8.6" Eaton differentials require special bearings. For axles with small bearing bores (race O.D. of 2.89"), usually found on vehicles prior to 1999, bearing LM-102949 and race LM-102911 are required. For axles with large bearing bores (race O.D. of 3.06"), usually found on vehicles from 1999 to present, bearing LM-603049 and race LM-603012 are required.										

Year	Description	Axle Shaft Dia.	Shaft Spline	Ring Gear Pinion Ratio	Detroit Locker	Detroit Truetrac	Detroit E-Z Locker	Eaton Posi	Eaton ELocker
CHEVROLET/GMC									
10/1500 • Pickup • Blazer/Jimmy • Suburban • Tahoe • Yukon • Van (continued)									
1982-06	GM 14 Bolt IFS	9.25"	33	All					19622-010
1981-06	GM 14 bolt C-Clip	9.5"	1.37" 33	All	225C135A	914A538		19590-010	19684-010
20/2500 • Pickup • Suburban • Rally/Sport • Van									
1977-91	GM 10 bolt	8.5"	1.20" 28	2.73 & up	187C149A	912A557	813A022	19557-010(mh)	
1988-91	GM 10 bolt	8.5"	1.31" 30	2.73 & up				19559-010(mh) 19659-010	
To 1980	Dana 44	8.5"	1.31" 30	3.73 & dn 3.92 & up	187SL16D 187SL16C	913A591 913A333	813A014 813A014	19695-010 19747-010	
1988-06	GM 10 bolt C-Clip (Van) 8.5/8.6"		1.32" 30	2.73-5.13+	187C148A	913A481	813A023	19559-010	19659-010
1978-89	GM 10 bolt C-Clip (Van) 8.5"		1.20" 28	2.73-5.13+	187C149A	912A556	813A022		
1981-06	GM 14 bolt C-Clip	9.5"	1.37" 33	All	225C135A	914A538		19590-010	19684-010
1972-06	GM 14 bolt	10.5"	1.50" 30	4.10 & dn	225S10 (a)	915A545		19689-010	
1973-06	GM 14 bolt	10.5"	1.50" 30	4.56 & up	225S10 (a)	915A547 (x)		19610-010	
1975-77	Dana 60HD	9.75"	1.50" 35	4.10 & dn 4.56 & up	225SL29B 225SL29A	915A385 915A386			
To 1974	Dana 60	9.75"	1.31" 30	4.10 & dn 4.56 & up	225SL19B 225SL19A	913A389 913A390		19730-010 19734-010	19722-010 19737-010
	Dana Super 60	9.75"	1.70" 40	4.10 & dn	225SL193A				
	Dana Super 60	9.75"	1.70" 40	4.56 & up	225SL193B				
30/3500 R/V • Chassis-Cab • Motor Home • Bus Chassis • Pickup C/K • Van									
1977-87	Dana 60HD	9.75"	1.50" 35	4.10 & dn 4.56 & up	225SL29B 225SL29A	915A387 915A388			19760-010 19761-010
1988-06	GM 14 bolt C-Clip	9.5"	1.37" 33	All	225C135A	914A538			
1973-06	GM 14 bolt	10.5"	1.50" 30	4.10 & dn 4.56 & up	225S10 (a) 225S10 (a)	915A545 (x) 915A547 (x)			
1973-94	Dana 70HD with 4" dia. axle tubes FLAT STYLE CAB 10.5" 5/8" Pinion Offset 5/8" Pinion Offset		1.50" 35 1.50" 35	4.10 & dn 4.56 & up	225SL58B 225SL58A				
1988-89	Dana 70-3U HD w/3.5" dia. axle tubes AERODYNAMIC CAB: 10.5" 5/8" Pinion Offset 31/32" Pinion Offset		1.50" 35 1.50" 35	3.21, 3.42 3.54-4.56	225SL58A 225SL58E				
1973-91	Dana 60HD (G Series) 9.75"		1.50" 35	4.10 & dn 4.56 & up	225SL29B 225SL29A	915A385 915A386			19760-010 19761-010
1984-86	Dana 70U	10.5"	1.50" 35	4.10 & dn	225SL58D				
1979-80	Dana 70B	10.5"		4.56 & up	225SL58C				
To 1986	GM 11000 lb.	12"	1.75" 27	All	250S27				
1986-92	GM 11000 lb. (Rockwell)		1.70" 28	All	225S52				
3500 HD									
1991-00	Rockwell C-102		1.70" 28	All	225S52				
1992-06	Dana 80	11.5"	1.60" 37	4.10 & up 3.73 & dn	225SL105A	916A427 916A566			

(mh) manual locking hubs recommended

All GM 8.5"/8.6" Eaton differentials require special bearings. For axles with small bearing bores (race O.D. of 2.89"), usually found on vehicles prior to 1999, bearing LM-102949 and race LM-102911 are required. For axles with large bearing bores (race O.D. of 3.06"), usually found on vehicles from 1999 to present, bearing LM-603049 and race LM-603012 are required.

(a) 225S10 differential replaces the conventional differential internals used in certain 1973 thru present GM axles. If it is to be installed in a GM axle equipped with an optional Eaton differential, it will also be necessary to purchase a new gear support case assembly, GM #6258336 or #6258340, depending upon gear ratio.

Year	Description	Axle Shaft Dia.-Spline	Ring Gear Pinion Ratio	Detroit Locker	Detroit Truetrac	Detroit E-Z Locker	Eaton Posi	Eaton ELocker
CHRYSLER/DODGE/PLYMOUTH								
D-50, 100, 150, 200 & 250, A, B, D, W								
Pickup • Power Wagon • Ramcharger • Sportvan • Van								
1989-02	Dana 44, one side C-Clip 8.5"	1.31"	30	3.73 & dn 3.92 & up		913A591 913A592	813A014 813A014	
To 1984	Dana 44	8.5"	1.31"	30	3.73 & dn 3.92 & up	187SL16D 187SL16C	913A591 913A592	813A014 813A014
1971-93	Dana 60HD	9.75"	1.50"	35	4.10 & dn 4.56 & up	225SL29B 225SL29A	915A387 915A388	19695-010 19747-010 19760-010 19761-010
To 1972	Dana 70	10.5"	1.50"	23	All	225S14		
1997-06	Chrysler C-Clip	8.375"	1.21"	29	All	187C179A	912A553	
1969-96	Chrysler C-Clip	8.375"	1.17"	27	All	187C151A		
1974-06	Chrysler C-Clip	9.25"	1.32"	31	2.76-4.56	187C172A	913A368	
1969-74	Chrysler	8.75"	1.28"	30	2.76-4.56	187SL14A	913A572	
1969-74	Chrysler	8.75"	1.31"	33	2.76-4.56		914A583 (pa)	
(pa) 33 spline units are made to fit axles cut with 45 degree pressure angle.								
1972-02	Dana 60	9.75"	1.31"	30	4.10 & dn 4.56 & up	225SL19B 225SL19A	913A389 913A390	19730-010 19734-010 19722-010 19737-010
To 1971	Dana 60	9.75"	1.24"	16	4.10 & dn 4.56 & up	225S12C 225S12A		
1972-90	Dana 70	10.5"	1.50"	35	4.10-3.54 4.56 & up	225SL58D 225SL58C		
1991-02	Dana 70	10.5"	1.41"	32	4.10 & dn 4.56 & up	225SL107D 225SL107C		
	Dana Super 60	9.75"	1.70"	40	4.10 & dn	225SL-193A		
	Dana Super 60	9.75"	1.70"	40	4.56 & up	225SL-193B		
300, 350, 400, B, C, M, W								
Chassis-Cab • Motor Home • Pickup • Power Wagon • Van								
1976-00	Dana 60HD	9.75"	1.50"	35	4.10 & dn 4.56 & up	225SL29B 225SL29A	915A387 915A388	19760-010 19761-010
1971-76	Dana 70	10.5"	1.50"	35	4.56 & up (7)	225SL58C		
1974	Dana 70	10.5"	1.50"	23	All	225S14		
1975-02	Dana 60, 60HD, 60M 9.75"	1.31"	30	4.10 & dn 4.56 & up	225SL19B 225SL19A	913A389 913A390	19730-010 19734-010	19722-010 19737-010
1991-02	Dana 70	10.5"	1.41"	32	4.10 & dn 4.56 & up	225SL107D 225SL107C		
1972-90	Dana 70	10.5"	1.50"	35	4.10 & dn (7) 4.56 & up (7)	225SL58D 225SL58C		
1972-85	Dana 70HD	10.5"	1.50"	35	4.10 & dn (7) 4.56 & up (7)	225SL58B 225SL58A		
1971-74	Dana 70	10.5"	1.50"	35	All	225S18		
To 1974	Dana 70	10.5"	1.50"	23	All	225S14		
1994-02	Dana 80	11.5"	1.52"	35	4.10 & up 3.73 & dn	225SL131A	915A450 915A567	

(B) with or without ABS

Year	Description	Axle Shaft Dia.-Spline	Ring Gear Pinion Ratio	Detroit Locker	Detroit Truetrac	Detroit E-Z Locker	Eaton Posi	Eaton ELocker
FORD								
Ranger • Explorer • Aerostar • Bronco II • Mustang								
1991-95	Dana 35 IFS Snap ring	1.14"	27	3.54 & up	162C56A		812A020 (j) 812A025 (h)	
1996-05	Ford IFS Front	8.8"	1.20"	28	All	912A563		19685-010
1983-06	Ford C-Clip	7.5"	1.20"	28	All	162C57A	912A316	
1987-06	Ford C-Clip	8.8"	1.32"	31	All	187C145A(+)	913A561	813A024
1983-06	Ford C-Clip	8.8"	1.20"	28	All	187C147A(+)	912A562	19588-010
1983-86	Ford C-Clip	8.8"	1.32"	31	All	187C146A		19605-010
To 1979	Ford	9"	1.20"	28	All	187SL13A	912A587	813A027 (w)
To 1978	Ford	8"	1.20"	28	All	187S13D	912A580	813A027 (w)
(h) 1.558" Hub dia. (j) 1.616" Hub dia. (w) without side gears								
F/E-100/150 • Pickup • Bronco • Van • Expedition • Crown Victoria								
1983-96	Dana 44 C-Clip	8.5"	1.31"	30	3.73 & dn 3.92 & up	913A591 913A592	813A014 813A014	19695-010 19747-010
1997-06	Ford IFS	8.8"	1.20"	28	All	912A548		19685-010
To 1982	Dana 44	8.5"	1.31"	30	3.73 & dn 3.92 & up	187SL16D 187SL16C	913A591 913A592	813A014 813A014
1997-06	Ford	9.75"	1.37"	34	All	225C194A	913A477	19627-010
1987-03	Ford C-Clip	8.8"	1.32"	31	All	187C145A(+)	913A561	813A024
1983-86	Ford C-Clip	8.8"	1.32"	31	All	187C146A(+)		19588-010
1976-87	Ford	9"	1.32"	31	All exc. 2.72	187SL17B	913A382	813A027 (w)
To 1979	Ford	9"	1.50"	35	All exc. 2.72	187S160A		
1977-79	Dana 44	8.5"	1.31"	30	3.73 & dn 3.92 & up	187SL13A 187SL16D 187SL16C	912A587 913A312 913A313	813A027 813A014 813A014
To 1974	Ford 9" 1.62" bearing hub dia.	1.20"	28	All	187S13A		813A027	
(w) without side gears								
F/E-250 (98' Super Duty) • Pickup • Van • Excursion								
1997-06	Ford IFS Snap ring	8.8"	1.20"	28	All	187C147A(+)	912A563	19685-010
1983-97	Dana 44 C-Clip IFS	8.5"	1.31"	30	3.73 & dn 3.92 & up	913A591 913A592	813A014 813A014	
To 1982	Dana 44	8.5"	1.31"	30	3.73 & dn 3.92 & up	187SL16D 187SL16C	913A591 913A592	813A014 813A014
1980-05	Dana50	9"	1.31"	30	3.54 & dn			
1979	Dana 60 (f)	9.75"	1.50"	35	4.10 & dn 4.56 & up	225SL29B 225SL29A	915A387 915A388	19760-010 19761-010
1983-84	Ford C-Clip	8.8"	1.32"	31	All	187C145A(+)		19588-010
1985-05	Ford	10.25"/10.5"	1.50"	35	All	225SL56A	915A550	19694-010
1983-85	Dana 70U	10.5"	1.50"	35	4.10 & dn (7) 4.56 & up (7)	225SL58D 225SL58C		
1974-87	Dana 61-1	9.75"	1.31"	30		See Note (6)		
1975-84	Dana 60-3	9.75"	1.31"	30	4.10 & dn 4.56 & up	225SL19B 225SL19A	913A389 913A390	19722-010 19737-010
To 1974	Dana 60	9.75"	1.31"	16	4.10 & dn 4.56 & up	225S12C 225S12A		
	Dana Super 60	9.75"	1.70"	40	4.10 & dn	225SL193A		
	Dana Super 60	9.75"	1.70"	40	4.56 & up	225SL193B		
F/E 350, 450, 550 • (98' & up Super Duty) • Pickup • Van • Wagon • Chassis-Cab								
1979-06	Dana 60	9.75"	1.50"	35	4.10 & dn	225SL29B	915A387	19760-010
1978-79	Dana 60	9.75"			4.56 & up	225SL29A	915A388	19761-010
1981-87	Dana 61-1	9.75"	1.31"	30		See Note (6)		
1983-97	Dana 70-U-1,-2	10.5"	1.50"	35	4.10 & dn (7) 4.56 & up (7)	225SL58D 225SL58C		
1975-85	Dana 70HD	10.5"	1.50"	35	4.10 & dn (7) 4.56 & up (7)	225SL58B 225SL58A		
1978-79	Dana 60 (f) Snowplow package only	9.75"	1.31"	30	4.10 & dn 4.56 & up	225SL19B 225SL19A	913A389 913A390	19730-010 19734-010
To 1974	Dana 60	9.75"	1.31"	16	4.10 & dn 4.56 & up	225S12C 225S12A		19722-010
To 1972	Dana 70	10.5"	1.50"	23	All	225S14		19737-010

Year	Description	Axle Shaft Dia.-Spline	Ring Gear Pinion Ratio	Detroit Locker	Detroit Truetrac	Detroit E-Z Locker	Eaton Posi	Eaton ELocker
F/E 350, 450, 550 • (98' & up Super Duty) • Pickup • Van • Wagon • Chassis-Cab (continued)								
1990-98	Dana 80	11.5"	1.80" 37	4.10 & up	225SL105A	918A427		
1998-03	Dana 80	11.5"	1.50" 35	3.73 & dn	225SL131A	915A567		
1998-03	Dana S135		1.84" 36	4.63-5.38	250SL166			
	Dana Super 60	9.75"	1.70" 40	4.10 & dn	225SL193A			
				4.56 & up	225SL193B			
HUMMER								
Front	AMC 20 IFS	8.875"	1.27" 29	3.08 & up	187C147A		813A016	
Front	AMC 20 IFS	8.875"	1.27" 29	2.73 & dn	187SL163A	912A549		813A016
To 1998	AMC 20 IRS	8.875"	1.27" 29	3.08 & up	187C147A	912A579		813A016
To 1998	AMC 20 IRS	8.875"	1.27" 29	2.73 & dn	187SL163A	912A573		813A016
HYUNDAI								
Santa Fe								
	AWD rear axle 10 bolt		27	3.81				19567-010
ISUZU								
Rodeo								
1993-00	Dana 44	8.5"/9"	1.31" 30	3.73 & dn	187SL16D	913A589		813A014
				3.92 & up	187SL16C	913A590		813A014
(US onl ¹)								
1989-£	10 bolt	7.5"	1.20" 28	3.23 & up	162C59A	912A317(x)		
JEEP								
Wrangler • Cherokee • Grand Cherokee • Wagoneer • CJ & DJ • Post Office Truck								
1971-06	Dana 30 (g)		1.16" 27	3.54 & dn	162SL60A	912A374		812A012
				3.73 & up	162SL60B	912A585		812A012
1970-03	Dana M-44-IF, IFHD (g)		1.31" 30	3.73 & dn	187SL16D	913A334		813A014
				3.92 & up	187SL16C	913A333		813A014
1997-00	Chrysler C-Clip	8.375"	1.21" 29	All	187C179A	913A553		
1991-96	Chrysler C-Clip	8.375"	1.17" 27	All	187C151A			
1993-03	Dana 35 C-Clip	7.56"	1.18" 27	3.54 & up	162C56A	912A569		812A025(h)
1984-93	Dana 35 C-Clip	7.56"	1.18" 27	3.54 & up	162C56A	912A569		812A020(j)
1985-89	Dana 35 non C-Clip	7.56"	1.18" 27	3.54 & up	162C56A	912A569		812A020
	Dana Super 35	7.56"	30		162C-66A			
1997-03	Wrangler Dana 44	8.5"	1.31" 30	3.73 & dn	187SL16D	913A589		813A014
1969-79	Various Dana 44	8.5"		3.92 & up	187SL16C	913A590		813A014
1966-68	Dana 44	8.5"	1.25" 19	3.73 & dn	187SL12B			19695-010
				3.92 & up	187SL12A			19747-010
	Dana Super 44	8.5"	1.36" 33		187SL192A			
1974-88	Dana M60-3R	9.75"	1.31" 30	4.10 & dn	225SL19B			
				4.56 & up	225SL19A			
6/76-86	AMC 20	8.875"	1.27" 29	3.08 & up	187SL47A	912A579		813A016
				2.73 & dn	187SL163A	912A573		813A016
(g) Does not fit axle disconnect Dana 44 1982-85; Dana 30 Cherokee 1984-92, Wrangler 1987-95 (h) 1.558" Hub dia. (j) 1.616" Hub dia.								
KIA								
Sportage • Sorento								
1993-97	Sportage 10 bolt		26	All				19519-01S
1998-06	Sportage 10 bolt		28	4.44				19536-020
2003-06	Sorento 10 bolt		34	All				19651-020

Year	Description	Axle Shaft Dia.-Spline	Ring Gear Pinion Ratio	Detroit Locker	Detroit Truetrac	Detroit E-Z Locker	Eaton Posi	Eaton ELocker
LAND ROVER								
Rover Type & Salisbury								
1993-00	Rover Type (k)	1.24" 24	3.54	187SL173A	912A407			
1985-93	Rover Type (m)	1.11" 10	3.54	187SL174A	910A416			
To 1985	Rover Type	1.11" 10	4.7		910A461			
	Salisbury 8HA	1.24" 24	3.54	225SL36				
1993-00	Rover Type (n)	1.24" 24	3.54	187SL173A	912A383			
1985-93	Rover Type (p)	1.11" 10	3.54	187SL174A	910A400			
To 1985	Rover Type	1.11" 10	4.7		910A460			
	Salisbury 8HA	1.24" 24	3.54	225S36				
	Salisbury 101 Rear	1.44" 22	5.37	225SL183				
	Salisbury Defender	24	4.10 & dn		912A593			
(k) Axle serial numbers 49L11363C or 57L05188B and later								
(m) Axle serial numbers and later: Range Rover - suffix H, 88/109 4 cyl. ¾ ton - suffix H, 109 V8/1ton - suffix D								
(n) Axle serial numbers 35S18135C or 37S08651B and later								
(p) Axle serial numbers and later: Range Rover - suffix F, 88 -suffix G, 109 V8/1ton - (Salisbury standard), 109 4 cyl. ¾ ton - (Salisbury optional)								
MITSUBISHI								
Montero Sport								
	12 bolt, 3.5 L	12	4.625				19629-010	
NISSAN								
Titan • Pickup								
1993-05	Nissan	1.38" 32	All		913A582			
	H233	1.25" 31	All	187SL167A				
SUZUKI								
Samurai • Sierra								
1985-3/88	Suzuki	1.09" 26	All			810A019(r)		
(r) with side gears (w) without side gears								
TOYOTA								
4 Cylinder - Pickup • 4 Runner								
1986-95	7.5" IFS (t) (u)	1.30" 27	All		911A342	811A017		
1986-95	7.5" IFS (v)	1.10" 27	All		911A445			
1974-95	8" 2 pinion (v)	1.30" 30	All	187SL61A	913A609	813A015	19614-010	
1980-95	7.5" 2 pinion	1.30" 27	All		911A565	811A017		
1986-96	8" 4 pinion (v) 4x4 gas/turbo/diesel	1.30" 30	All	187SL61A	913A611	813A015		
1986-96	8" 4 pinion (w) 4x4 turbo/gas	1.30" 30	All	187SL61B	913A610*	813A028	19614-010(Tacoma only)	
1995-05	8.4" Tacoma, Tundra, T-100	1.29" 30	3.54-5.29	187SL199A	913A541			
	Toyota Legend Race Series	1.08" 27	All		911A565			
6 Cylinder - Pickup • 4 Runner								
1986-95	7.5" IFS (t) (u)	1.30" 27	All		911A342	811A017		
1986-04	7.5" IFS (v) 4 Runner only	1.10" 27	All		911A445			
1974-85	8" 2 pinion (v) 4x2 gas ½ ton	1.30" 30	All	187SL61A	913A348	813A028	19614-010	
6-95	8" 4 pinion (w) 4x4 gas, 4x2 cab chassis	1.30" 30	All	187SL61B	913A321	813A028	19614-010	
1995-05	8.4" Tacoma, Tundra, T-100	1.29" 30	3.54-5.29	187SL199A	913A541			
	Toyota Legend Race Series	1.08" 27	All		911A565			
Land Cruiser II								
1990-97	8" 4 pinion (lb)	1.30" 30	All	187SL61B	913A612	813A028		
1969-89	9.5" 2 pinion C-Clip	1.30" 30	All	187C152A		813A011		
	Australian 8 7/8"	1.31" 30	All	225SL124A				
1969-97	9.5" 2 pinion C-Clip	1.30" 30	All	187C152A		813A011		
	Australian 8 7/8"	1.31" 30	All	225SL124A				
* 32010X allows 913A610 in place of 913A611								
(t) Will not fit selector disconnect "shift on the fly"								
(u) Prior to 3-88 requires Toyota "small" hub bearing #90368-50006								
(v) "Small" hub bearing dia. 45 mm								
(lb) "Large" hub bearing dia. 50 mm								

Year	Description	Axle Shaft Dia.-Spline	Ring Gear Pinion Ratio	Detroit Locker	Detroit Truetrac	Detroit E-Z Locker	Eaton Posi	Eaton ELocker
------	-------------	---------------------------	---------------------------	-------------------	---------------------	-----------------------	---------------	------------------

PERFORMANCE

	Dana 30	7.2"	1.15" 27	3.73 & up				912A411
	Dana Super 35	7.56"	1.15" 30	3.54 & up	182C66A			
	Dana Super 44	8.5"/9"	1.36" 33	3.92 & up	187SL192A			
	Dana Super 60	9.75"	1.70" 40	4.10 & dn	225SL193A			
	Dana Super 60	9.75"	1.70" 40	4.56 & up	225SL193B			
	Chrysler	8.75"	1.20" 30	2.76-5.57	187SL14A		913A572	
	Chrysler	8.75"	1.31" 33	2.76-4.56			914A583 (pa)	
(pa) 33 spline units are made to fit axles cut with 45 degree pressure angle.								
	Ford	9"	1.50" 35	All exc. 2.72	187S160A			
	Ford	9"	1.32" 31	All exc. 2.72	187SL17B		913A586	
	Ford C-Clip	8.8"	1.32" 31	2.47-4.56	187C145A+		913A561	19588-010 19660-010
1999-00	GM 10 bolt C-Clip	8.6"	1.32" 30	2.73-5.13	187C148B			
1989-98	GM 10 bolt C-Clip	8.5"	1.32" 30	2.73-5.13	187C148A		913A481	19559-010 19659-010
1964-72	GM 12 Bolt car	8.875"	1.29" 30	3.08-3.90	187C197A		913A555	19559-010 19659-010
1964-72	GM 12 Bolt car	8.875"	1.41" 33	3.08-3.90	187C198A		914A576 (pa)	
1964-72	GM 12 Bolt car	8.875"	1.41" 33	4.10 & up			914A575 (pa)	
1964-72	GM 12 Bolt car	8.875"	1.50" 35	4.10 & up	187S196A			
	Dana 60 rear	9.75"	1.50 35	4.10 & dn 4.56 & up			915A385 915A386	
	Toyota Legend/Celica		1.08" 27	All			911A565	

(pa) 33 spline units are made to fit axles cut with 45 degree pressure angle.

Circle Track Racing Applications

Ford 9" CTR only	1.32" 31	All exc. 2.72	R18703A
Ford 9"	1.32" 31	All	R18706A (was 187N158A)
Ford 9" 2.00 Large Bearing	1.32" 31	All	R18707A (was 187N178A)
Quick Change (Franklin, Halibrand, Richmond, Winters, etc.)			
CTR only	1.32" 31	All	R18705A
Performance Detroit Locker	1.32" 31	All	R18708A (was 187N30A)

The Detroit Locker CTR (Circle Track Racing) version of the Detroit Locker is made exclusively for left hand turn racing only.

MotiveGear Performance®

Motive Gear®

SUPERWINCH®

WARN®



Hubs

SUPERWINCH® & WARN® HUBS

CHEVROLET®/GMC®/GEO® STYLE

REPLACES FACTORY AUTOMATIC HUBS

SUPERWINCH®#	WARN®#	DESCRIPTION
400439*	11690	K30 1 TON PICKUP '76-91
400442		GMC® 2.5 TON
400517		3/4 TON PICKUP '60-76
400518	9790	BLAZER '69-83
400518	9790	1/2 TON PICKUP '69-87
400518	9790	3/4 TON PICKUP '77-87
400522		LUV 4X4 ALL
400538	39198	TRACKER - ALL
400542		GMC® 2.5 TON

FORD® STYLE- AUTOMATIC

REPLACES FACTORY AUTOMATIC HUBS

SUPERWINCH®#	WARN®#	DESCRIPTION
400518	9790	BRONCO '87-97
400518	9790	1/2 TON F100 '59-86
400518	9790	1/2 TON F150 '76-96
400518	9790	BRONCO '66-86
400518	9790	1/2 TON F150 '76-96
400518	9790	3/4 TON F250, 3,000-LB. AXLE '59-75

CHRYSLER® STYLE

REPLACES FACTORY AUTOMATIC HUBS

SUPERWINCH®#	WARN®#	DESCRIPTION
400517	9078	1/2 TON PICKUP - '57-68
400518	9790	1/2 TON PICKUP - '69-75
400517	9072	3/4 TON PICKUP - '57-75
400518	9790	1/2 TON PICKUP, RAMCHARGER & TRAILDUSTER '81-84
400528		ARROW, D-50 4X4 THRU '81
400543		D-50 RAM 50 4X4 '82-93
400508		POWER WAGON WC-50 & 60 '42-56
400508		WM300 '57-75
400439*	11690	W250 & W350 4X4 '91
400541		W300 DODGE® 1 TON '79-89
400439*	11690	W350 4X4 '93

FORD® STYLE - AUTOMATIC

REPLACES FACTORY MANUAL HUBS

SUPERWINCH®#	WARN®#	DESCRIPTION
400518	9790	BRONCO '66-86
400518	9790	1/2 TON F150 '76-96
400518	9790	3/4 TON F250, 3,000-LB. AXLE '59-75
400517	9072	3/4 TON F250, 3,500 LB. AXLE '63-77
400518	9790	3/4 TON F250 SERIES, 3,500 LB. AXLE '78-86
400439*	11690	3/4 TON F250 & CREW CAB, 3,800 LB. AXLE (INTERNAL MOUNT) '78-97
400439*	11690	1 TON F350 SERIES, 4,500 LB. AXLE '76-97

DAIHATSU® STYLE

REPLACES FACTORY AUTOMATIC HUBS

SUPERWINCH®#	WARN®#	DESCRIPTION
400503		ROCK RUGGER - ALL
400520		4X4 - ALL

INTERNATIONAL HARVESTER® STYLE

REPLACES FACTORY AUTOMATIC HUBS

SUPERWINCH®#	WARN®#	DESCRIPTION
400501	29062	SCOUT '60-71
400502		SCOUT II, TERRA, TRAVELER '72-80
400517	9072	1/2, 3/4 TON PICKUP '56-67
400518	9790	1/2 TON PICKUP '68-75

*HUBS MADE TO MILITARY SPECIFICATION - COMES WITH NYLON DIAL.

SUPERWINCH® & WARN® HUBS

ISUZU® STYLE		
SUPERWINCH®#	WARN®#	DESCRIPTION
400522		4X4 PICKUP THRU '85
400532		4X4 PICKUP -72-80
400532	61424	TROOPER I & II '83-86
400533	61385	TROOPER II '87-93

SUZUKI®/GEO STYLE		
SUPERWINCH®#	WARN®#	DESCRIPTION
400530		SJ-410, 412, 413
400538	34581	SAMURAI, SIERRA '82-94
400538		SIDEKICK/TRACKER - ALL

LANDROVER® STYLE		
SUPERWINCH®#	WARN®#	DESCRIPTION
400405*		SERIES I, II, IIA, III, ALL W.B. 10 SPLINE AXLE '59-80
400406*		24 SPLINE AXLE '81-9

JEEP® STYLE		
SUPERWINCH®#	WARN®#	DESCRIPTION
400501	29062	CJ, UNIVERSAL '42-71
400502	9062	CJ, UNIVERSAL '72-80
400526	28751	CJ, UNIVERSAL '81-86
400518	9790	J10 PICKUP '74-90
400517	9072	J20 PICKUP '74-76
400518		J30 PICKUP '77-90
400518	29062	WAGONEER, CHEROKEE,

MITSUBISHI® STYLE		
SUPERWINCH®#	WARN®#	DESCRIPTION
400543		MONTERO '82-93
400543		PICKUP '82-9

TOYOTA® STYLE		
SUPERWINCH®#	WARNV#	DESCRIPTION
400504	28781	LANDCRUISER THRU '75
400519	28771	LANDCRUISER, PICKUP '76-84
400521		LANDCRUISER '79-91
400521		4X4 PICKUP '79-85
400513	28761	4X4 PICKUP 4RUNNER IFS '86-95 (EXCL. TACOMA)
400513	28761	MID-SIZE P/U T100 '93-94

NISSAN® STYLE		
SUPERWINCH#	WARN#	DESCRIPTION
400524		4X4 PICKUP '72-82
400544	29087	4X4 PICKUP '83-86
400529	28739	4X4 PICKUP W/4CYL. '86 1/2 -93
400545		4X4 PICKUP, PATHFINDER W/6 CYL. AND AUTOMATIC HUBS (31 SPLINE ONLY)
400523		PATROL '87-87

COMMERCIAL TRUCKS & HD AXLES		
SUPERWINCH®#	WARN®#	DESCRIPTION
400501		DANA® 25-27 AXLE, 10 SPLINE
400502		DANA® 30 AXLE, 27 SPLINE
400517		DANA® 44 HD AXLE 19 SPLINE (EXTERNAL MOUNT)
400518	9790	DANA® 44 AXLE 19 SPLINE (INTERNAL MOUNT)
400439*	11690	DANA® 60 AXLE 30 SPLINE (INTERNAL MOUNT)
		DANA® 70 AXLE

4X2 CONVERSION KITS
<ul style="list-style-type: none"> ☛ Convert Ford® and Chevrolet® trucks with "NEW PROCESS" 203 full-time transfer case to part-time 4WD/2WD. ☛ Retains stock transfer case shift pattern and shifter. ☛ Add Superhubs and front wheel drivetrain no longer turns 100% of the time. ☛ Adds better fuel economy.

PART#	APPLICATION
900801	Conversion Kit only (hubs not included).
900802	900801 plus Superhub set 400518, 1/2 ton hubs, Chevy®/GMC® truck, Blazer/Jimmy, Ford® F100/150, Bronco, F250 with 3,000 and 3,500 lbs. axle.
900803	900801 plus Superhub set 400517, 3/4 ton hubs, Chevy®/GMC® 3/4 ton, Ford F250 with 3,500 axle 1963-1977
900805	900801 plus Superhub set 400439, 1 ton hubs, Chevy®/GMC® K30 1 ton '78-present, Ford® F250/Crew Cab W/3800 axle, Ford® F350 1 ton W/4500 axle.

***HUBS MADE TO MILITARY SPECIFICATION - COMES WITH NYLON DIAL.**

RACE TESTED

UNMATCHED
power · performance · durability



Motive Gear
Performance® **AX** *Series*

Motive Gear Performance® AX Series Ring & Pinions are race tested and proven to be the cutting edge in lightweight performance gearing. Give your mustang champion level horsepower!

Professional drivers demand results, MGP provides the solutions...
Are you ready?

- ▶ *Computerized Heat Treatment*
- ▶ *First Ever Ratios: 4.22 to 7.33*
- ▶ *Gleason 5 Cut Technology*
- ▶ *Solid Shank Pinion Shaft*
- ▶ *Central Contact Pattern*
- ▶ *Indexed Tooth Spacing*
- ▶ *Cutting Edge Lapping*
- ▶ *CNC Start to Finish*



**Manual Transmission &
Transfer Case Reference**

**Ring & Pinion Set-up &
Troubleshooting Guide**

Guides

MANUAL TRANSMISSION & TRANSFER CASE

Transmission Experts

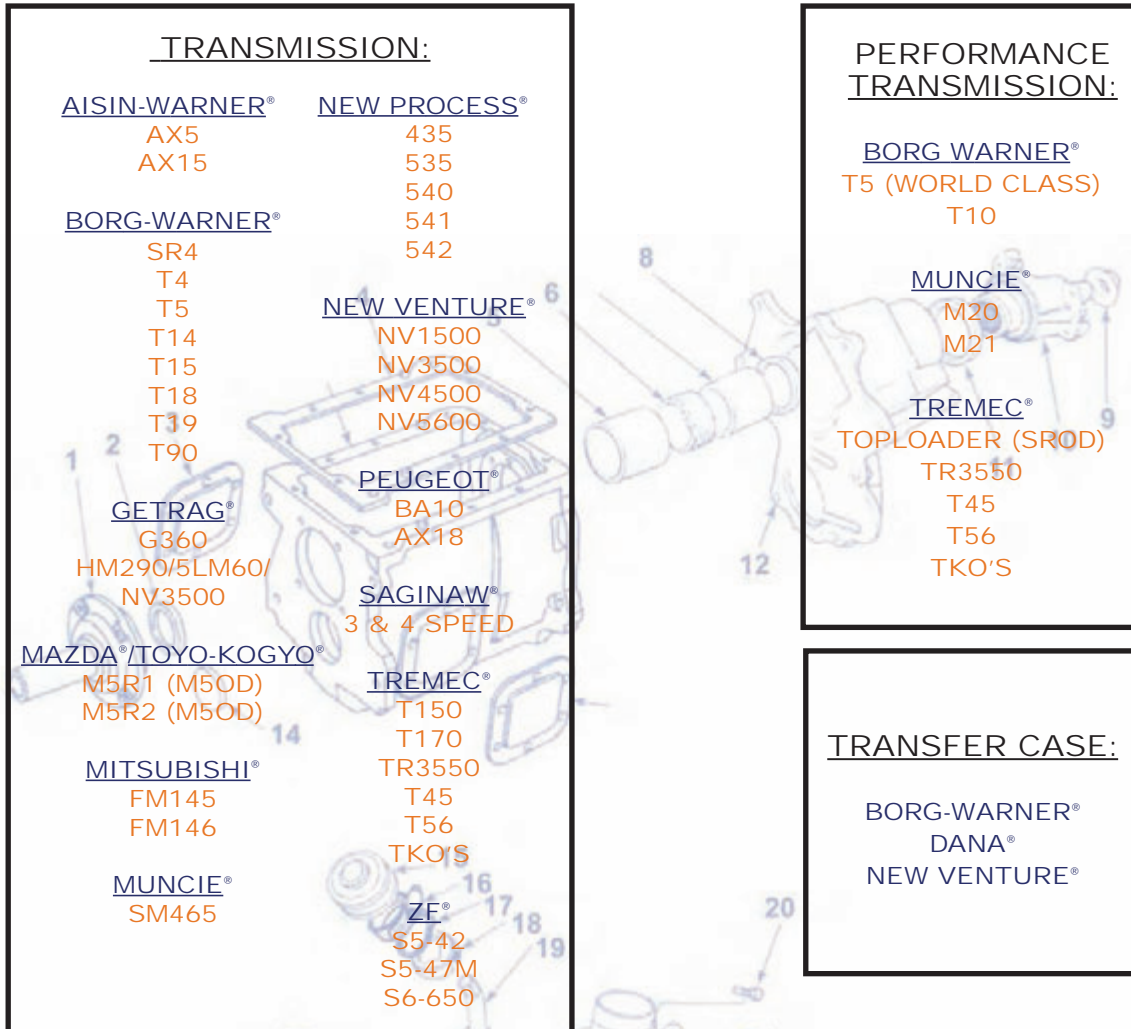

TRANSMISSION:

<u>AISIN-WARNER®</u>	<u>NEW PROCESS®</u>
AX5	435
AX15	535
	540
<u>BORG-WARNER®</u>	541
SR4	542
T4	
T5	<u>NEW VENTURE®</u>
T14	NV1500
T15	NV3500
T18	NV4500
T19	NV5600
T90	
<u>GETRAG®</u>	<u>PEUGEOT®</u>
G360	BA10
HM290/5LM60/ NV3500	AX18
<u>MAZDA®/TOYO-KOGYO®</u>	<u>SAGINAW®</u>
M5R1 (M5OD)	3 & 4 SPEED
M5R2 (M5OD)	
<u>MITSUBISHI®</u>	<u>TREMEC®</u>
FM145	T150
FM146	T170
	TR3550
	T45
	T56
	TKO'S
<u>MUNCIE®</u>	<u>ZF®</u>
SM465	S5-42
	S5-47M
	S6-650

PERFORMANCE TRANSMISSION:

BORG WARNER®
T5 (WORLD CLASS)
T10

MUNCIE®
M20
M21

TREMEC®
TOPLOADER (SROD)
TR3550
T45
T56
TKO'S

TRANSFER CASE:

BORG-WARNER®
DANA®
NEW VENTURE®

Midwest Truck & Auto Parts, Inc.™ has been in the light duty transmission business for **over 60 years**.

We provide new and rebuilt units for just about every manual transmission and transfer case, both foreign and domestic. We don't stop there as we also manufacture and wholesale gears, bearing kits and rebuild kits for transmissions and transfer cases.

From forks to complete rebuild kits, look to us for high quality parts and assemblies. We have listed some of the units and rebuild kits we carry and we have plenty more. Late model and early model parts and assemblies are our business and we want to help get the job done right the first time.



OFFROAD DOMINANCE

is achieved with Motive Gear® ring & pinions. The durability and power of these gears have been trail tested by professional and hard-core offroad enthusiasts.

RING & PINION SET-UP & TROUBLESHOOTING GUIDE

RING & PINION SET-UP & TROUBLESHOOTING GUIDE FOR MOTIVE GEAR® & MOTIVE GEAR PERFORMANCE®

1. Tear down unit and inspect for visible damage. Look closely for cracks, dents, etc. This includes a complete tear down of the carrier also. This is an area where foreign material can hide. Close inspection of the unit is important for a number of reasons:
 - a. Reporting damage to the customer.
 - b. Quoting accurately on damage.
 - c. Determining possible reason for initial failure.
 - d. Close attention should be paid to original set-up of ring & pinion.
2. Clean all parts thoroughly. This may require the use of a hot tank or similar equipment.
3. Inspect all components carefully for damage. Magna-fluxing is one way to accurately check for cracks that are unable to be seen with the human eye.
4. Look carefully at the vehicle axle housing for cracks. This is common in rearends such as GM® & Dana®/Spicer® housings where the axle tubes are pressed into the housing and only tack welded. This may have been the cause of the oil loss that led to the premature failure of your unit.
5. Clean axle housing thoroughly. Often foreign material is lying in axle tubes. When the unit is refilled with fresh oil, it will flush material into the new unit causing damage.
6. Check axle splines for spline distortion. This may give you trouble refitting axles.
7. Check that axle vent isn't blocked. A blocked breather will cause severe overheating.

Rear end set-up

1. Always verify you have purchased the correct gear ratio. This can be checked by dividing ring gear tooth count by the pinion tooth count.
e.g. Ring gear tooth count - 35T, pinion gear tooth count - 10T
(35 divided by 10 = 3.50:1)
2. Many differential housings have many thousands of miles of service. Check all threads in the housing for damage. Good practice is to run an engineering tap down the threads to clean and align threads. This is also mandatory on new housings. This will lead to more accurate torque settings.
3. Check side bearing adjusters as they are often warped and out of shape making ring and pinion settings difficult. Replace as necessary. Fitting new billet side adjusters will give you a more accurate set-up.
4. Check ring gear back face for flatness. Generally, after heat treating, there may be a degree of taper. This can be rectified by lapping gear on sandpaper on a glass flat plate. This will give you a more even and uniform pattern when setting up your new gear set.
5. Careful attention should be given to blue printing your rearend. Accurate clearance will lead to a longer life for your unit.
6. All new parts should be completely disassembled and cleaned before assembly.
7. Check all new parts for damage which may have occurred in shipping from manufacturer.
8. Examine the ring gear mounting surface for nicks or burrs which may prevent a flush mounting of the newly installed ring gear. Ring & pinion tooth depth variations can result in a ring gear that is cocked on its mounting surface. If a ring gear spacer is to be used, check it for distortion from heat treating and for surface imperfections.

RING & PINION SET-UP & TROUBLESHOOTING GUIDE

RING & PINION SET-UP & TROUBLESHOOTING GUIDE FOR MOTIVE GEAR® & MOTIVE GEAR PERFORMANCE®

9. **Only use new bearings, seal and crush washers** for the installation of your new ring & pinion.
 - Used bearings that are believed to be in good shape are generally destroyed after being pressed off and on again. Warping the bearing cage and chipping the bearing generally occurs.
 - When your customer wants to use the old bearings over because they were only installed 12 months before, explain this to him:
 - Average vehicle use - 2 hours a day
 - Average of 3000 rpm differential speed x 120 min. = 360,000 revolutions x 365 days a Year = 365 x 360,000 = 13,140,000 revolutions per year.
 - The rearend has seen a lot of action!!! Installing new bearings is the correct procedure when installing a new ring & pinion. The customer will be happier in the long run.
10. A common question is: What is the pinion depth? This may be printed on some pinions. If not, go ahead and install a pinion with OEM original shims. This will get you close, as many gear sets do not differ much in dimensions from stock.
11. Ring & pinions may bind in the differential housing for a variety of reasons:
 - a. Incorrect amount of pinion shims.
 - b. Crush collar not completely collapsed.
 - c. Pinion bearings not correctly seated on pinion.
 - d. Incorrect preload on pinion.
 - e. Lower numerical ratios, especially Ford® 9" style, may require grinding on the differential housing to obtain clearance.
 - f. Incorrect differential case.
 - g. Ring gear may require spacer.

If you have trouble determining the cause of the problem or correcting it, please call us for assistance.
12. When fitting new ring gear to case, torque down bolts in a cross-over action, torquing in increments of 25 ft. lbs. at a time to the final torque setting. This will allow ring gear to sit correctly on the case and will prevent cocking of the gear.
13. Assemble the unit taking care that bearings, especially side bearings, are sitting correctly in the bearing housing. Side adjusters, if applicable, should mate against the outside edge of the bearing.
14. Set your backlash with a dial test indicator (dti) to the recommended specifications.
15. Turn the ring & pinion over 360 degrees both ways and check your pattern or drive and coast sides. Hopefully, the pattern is within limits. If not, you may have to lower or raise pinion depth and/or move the ring gear closer to the pinion or open up this clearance.
16. Once this pattern is within specifications, go ahead and torque up all bolts, especially main bearing cap bolts. Re-check backlash with a dti. This clearance may change...it will need to be readjusted to rectify this if it happens.
17. The unit should now be ready to go. Keep it free from dirt and moisture before fitting. This can lead to failure, because it will keep lubrication from critical load areas.
18. **Fill unit with oil.** Use recommended lube e.g. manufacturers specs. Many times a rearend is test driven without oil. The only oil present is initial lubrication on the bearings. Another practice is to assemble rearends dry. This is a concept believed to help the rearends run in quicker. **This is NOT general practice. The gears and bearings lose their heat treat immediately, causing extensive damage. Gears should be run in at moderate speeds with maximum lubrication.**

RING & PINION SET-UP & TROUBLESHOOTING GUIDE

RING & PINION SET-UP & TROUBLESHOOTING GUIDE FOR MOTIVE GEAR® & MOTIVE GEAR PERFORMANCE®

19. Change the rearend fluid at 1000 miles. This is because during break-in, the gears and bearings will have some material chip off or wear off, contaminating the fluid. Many chemicals used in heat treating or case hardening are from the potassium nitrate family. This mixed with gear oil produces a number of corrosive acids. These acids also break down the oil film, rendering the lubricant useless. Steel to steel contact then happens leading to ultimate failure.
20. While inspection plate is off, have a general look at the gears and support parts for strange or irregular wear.
21. Lubricate if it smells burnt. There may be good reason to look further, especially if it is a posi. Burnt clutches may be the conclusion.
22. Use only high quality oils. Low quality oils only have half the additives needed e.g. moly, lithium etc.....
23. Check general area around rearend, especially suspension top arms etc...rearend noise may not only be ring & pinion. It may be axle bearings, suspension, tires, transmission or more commonly in vans & pick-ups, poor floor installation and normal gear noise.
24. Troubleshooting the correct problem will help the customer, installer and manufacturer. Remember, **THERE ARE ACCEPTABLE NOISE LEVELS** which vary from manufacturer to manufacturer. **Noise that may be normal as per manufacturer, may be strange to a consumer unaware of acceptable noise.** Explain acceptable noise levels to your customer. If noise remains an issue, double check your tolerances for accuracy, then call us for help.
25. Break in of gears is paramount to gear life. Initial run in should be at low speeds. This will enable gears to run in without overheating.

Summary

Properly designed, manufactured and maintained Motive Gear® and Motive Gear Performance® ring gear and pinions, correctly assembled with new bearings and seals in a clean, rigid gear box, and operated with the proper lubricant, should result in safe and satisfactory performance. Be sure application of your gear set is the correct one.

TORQUE SPECIFICATIONS

Ring Gear Bolts

3/8" x 7/8" RH	55-60 FT #
3/8" x 3/4" RH	45-50 FT #
3/8" ALL LH	45-50 FT #
7/16" ALL	60-65 FT #
1/2" ALL	100-110 FT #

Carrier Cap Bolts

7/16" (5/8" HEAD)	60-65 ft #
1/2" (3/4" HEAD)	80-85 ft #

MotiveGear
Performance®

Motive
Gear®

MOTIVE GEAR® RING & PINIONS



Motive Gear® High Performance Ring & Pinions

These high performance ring and pinions are made from 8620 steel. Rigorous testing is required to meet our standards and your demands.

Motive Gear® Ring & Pinions Motive Gear® stock performance ring and pinions are excellent replacements for original equipment. Installers prefer our ring and pinions for easy setup, superior strength and quality, and our vast ratio selection.

Specialized
Processes:

- CNC start to finish
 - Central contact pattern
 - Solid shank pinion shaft
 - Computer controlled heat treatment

AX Series Ring & Pinion

The AX Series ring and pinion is a “production lightened” gear set with up to 2 pounds of rotating weight removed *before* heat treatment.

Less rotating weight = faster acceleration & *higher speeds*

The AX ring and pinion is also available in a Pro Gear application of 9310 steel with your choice of small and large pinion.



Find this valuable information PLUS Ring & Pinions, Installation Kits, Mini & Full Spools, Ring Gear Spacers, Limited Slip Gear Oil, and Gaskets in our Application Guide



MOTIVE GEAR® APPLICATION GUIDE

Bearing Kits

Motive Gear® assembles and stocks more differential, manual transmission, and transfer case bearing kits than many suppliers in the country. High quality OE brands such as Timken® and Koyo® are used in our bearing kits. Master Kits, seal and gasket kits, installation kits, gasket only kits, you name it, Motive Gear® can supply it! Don't forget, Motive Gear® is one of the largest suppliers in the Nation of individual bearings and seals, including: tapered, roller, cylindrical, and ball bearings - in all of the quality brands that you know and trust. Look to Motive Gear® for all of your bearing needs.



Spools and Cases

Motive Gear® supplies and stocks a full line of mini and full spools for applications including: AMC®, Chrysler®, Dana®, Ford®, GM®, and Toyota®. These high quality spools are manufactured using only 4140 high strength steel, and are available in a variety of axle splines.



OE equivalent cases are also available from Motive Gear®, for both open and posi traction applications. Cases are available both empty and loaded. Please contact a sales representative for details and availability.

Gear Oil & Additives

To help you complete the job right, Motive Gear® supplies high quality 75W-140 GL-6 synthetic gear oil, made exclusively for Motive Gear® by Torco®. This gear oil was specially formulated for Motive Gear® and Motive Gear Performance® ring and pinions; and blended to include limited slip additive for use in all posi-traction applications. Motive Gear® also supplies Torco® formulated limited slip friction modifier for type F and Type G applications.



Internal Kits

Motive Gear® supplies internal kits for open and posi differentials. These kits include:

Open Differential:

Side gears, side gear washers, pinion gears, pinion gear washers, pinion shaft and lock bolt or roll pin.

Posi Differential: Side gears, side gear washers, pinion gears, pinion gear washers, pinion shaft, pinion block (where applicable), lock bolt or roll pin and clutches or posi plates and retainers (where applicable).

Find this valuable information PLUS Ring & Pinions, Installation Kits, Mini & Full Spools, Ring Gear Spacers, Limited Slip Gear Oil, and Gaskets in our - Application Guide



MOTIVE GEAR® APPLICATION GUIDE

Yokes

Yoke packages come complete with everything you need to install, including: grade 8 locknut, washer, and chromoly u-bolts.

- All cast and forged yokes are top quality
- All billet chromoly yokes are 4120 or 4240H bar stock, heat treated to 34-38 Rockwell® C
- All true billet yokes have the finest and most consistent quality heat treat control available.



Axle Shafts

Motive Gear® has supplied quality axle shafts for light duty, medium duty, off road and high performance applications for years. Our line is constantly expanding and we strive to support the ever-changing market place with more options every year. All stock performance axle shafts by Motive Gear® are quality replacements for original equipment.

U-Joints



Motive Gear® stocks a complete line of quality replacement u-joints for car and truck applications, including popular 1310, 1330, 1350 and 7260 sizes.

When quality, selection, availability and price matter, use only Motive Gear® trail tested u-joints!

Rebuilt Manual Transmission & Transfer Case

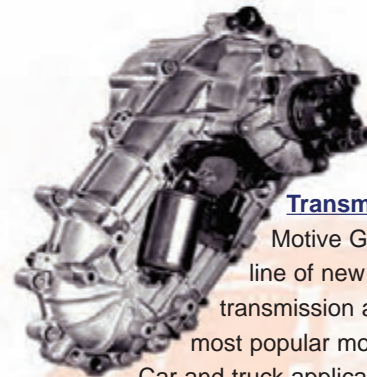

Motive Gear® stocks a complete line of new and rebuilt manual transmission and transfer cases for most popular models. Car and truck applications for 3, 4, 5, and 6 speeds are included in our inventory, and are fully warranted by Motive Gear® the name you can trust!



*Find this valuable information PLUS Ring & Pinions, Installation Kits, Mini & Full Spools, Ring Gear Spacers, Limited Slip Gear Oil, and Gaskets in our **NEW** Application Guide*