

# 16K ORBITAL ROTATING RUBBER PIN BOX\*

OPERATING INSTRUCTIONS AND OWNER'S MANUAL



Above. Beyond. Always.

\* Patented

Congratulations on the purchase of the MORryde 16k Orbital Rotating Rubber Pin Box. This revolutionary new system redefines the experience of towing a 5th wheel. No longer will you have to live with the harsh, jerky, back-and-forth motion associated with towing. You can also forget about excessive wear and tear on your truck and RV and the added strain this puts on drivers and passengers.

**Key features of the Orbital Rotating Rubber Pin Box System:**

- True 90° turning without the use of a slider hitch
- Greatly reduced back-and-forth chucking and jerking
- Cushioned sensation over uneven road conditions
- Jerk-free starts and stops
- Smoother, more comfortable in-cab ride
- Locking wedge to prevent pivot at the 5th wheel hitch
- Greaseable spindle for smooth rotation
- Large conical lock washers to hold wedge in place
- Integrated holes for lockout bolt storage

Each MORryde Orbital Rotating Rubber Pin Box has been carefully engineered to match the existing pin box that it replaces. Our pin box is fully adjustable\* and maintains the king pin location established by the original trailer manufacturer. By maintaining the static king pin location, stress and strain subjected to the trailer frame structure is consistent with the original king pin location.

This manual will outline basic troubleshooting and preventative maintenance procedures associated with this system. Service manuals and instructions are provided with replacement parts.

\* The MORryde Rotating Rubber Pin Box is fully adjustable for most applications.



Above. Beyond. Always.

## CONTENTS

Parts List .....	3
Preparation	
• Product and Safety Information .....	4
• Tow Rating Checks.....	4
• Use of Manual .....	4
• Torque Specifications .....	4
• Cab Clearance Check .....	5
• Bumper Clearance Check .....	6
Operating Instructions	
• Standard Transport .....	7
• Rear Rotation Transport .....	7
Wedge Installation .....	8-9
Wedge Guide .....	10
Hitching Instructions	
• Procedure .....	11
• Pull Test .....	12
Compatibility .....	13
Pre-Travel Inspection .....	13
Maintenance .....	13
Troubleshooting .....	14
Warranty .....	14

# PARTS LIST

ITEM	QTY	PART NUMBER	DESCRIPTION	ITEM	QTY	PART NUMBER	DESCRIPTION
1	1	006-239-00	CASTLE NUT, 1 1/2-12	19	4	UO115-117	HEX BOLT, 5/16-18 X 1 GR5
2	1	031-030-02	TAPERED BEARING	20	4	UO115-173	HEX BOLT, 9/16-12 X 1-1/2 GR5
3	1	25520	BEARING RACE	21	4	UO115-204	BUTTON HEAD, 5/16-18 X 3/4
4	1	IS140-006-W	FIBER BEARING, 2-1/2 ID X 1-1/4	22	10	UO115-219	THREAD ROLLING SCREW, 1/4-20 X 3/8
5	1	RPB707-003S	RUBBER SPRING 30 DURO	23	1	UO115-798	HEX BOLT, 5/8-18 X 1-1/4 GR8
6	4	RPB710-004	STABILITY BLOCK	24	2	UO115-823	HEX BOLT, 5/8-18 X 1-1/2 GR8
7	4	RPB710-005	GLIDE DISC	25	2	UO115-824	HEX BOLT, 5/8-18 X 2 GR8
8	2	RPB712-008	RETAINMENT RODS	26	8	UO116-039	SERRATED FLANGE NUT, 7/16-14
9	2	RPB717-001	RUBBER BUMPER	27	4	UO116-249	SERRATED FLANGE NUT, 5/16-18
10	2	RTPB162-001	ORBITAL DECAL	28	1	RTPB117-001	WASHER, 1-1/2 ID X 3-1/2 OD X 1/4
11	1	RTPB162-002	WARNING LABEL	29	5	UO117-162	WASHER, 5/8 CONICAL LOCK
12	1	RTPB162-1622	RATING LABEL	30	1	UO136-1794	COTTER PIN, 1/4 X 4
13	1	RTPB70-1622	PIN BOX, 16K	31	4	UO136-181	ACCESS PLUG
14	1	RTPB71-005	SKID PAD	32	1	UO136-1986	WEAR PLATE
15	2	RTPB723-039	TRIANGULAR COVER PLATE	33	4	UO136-238	T-NUT 5/16-18 X 5/8
16	2	RTPB723-040	SPACER PLATE	34	2	UO162-001	MORRYDE OVAL DECAL
17	1	RTPB75-011	STANDARD WEDGE	35	1	UO162-049	DATE CODE LABEL
18	1	RTPB75-029	SPINDLE BOX				

figure 1

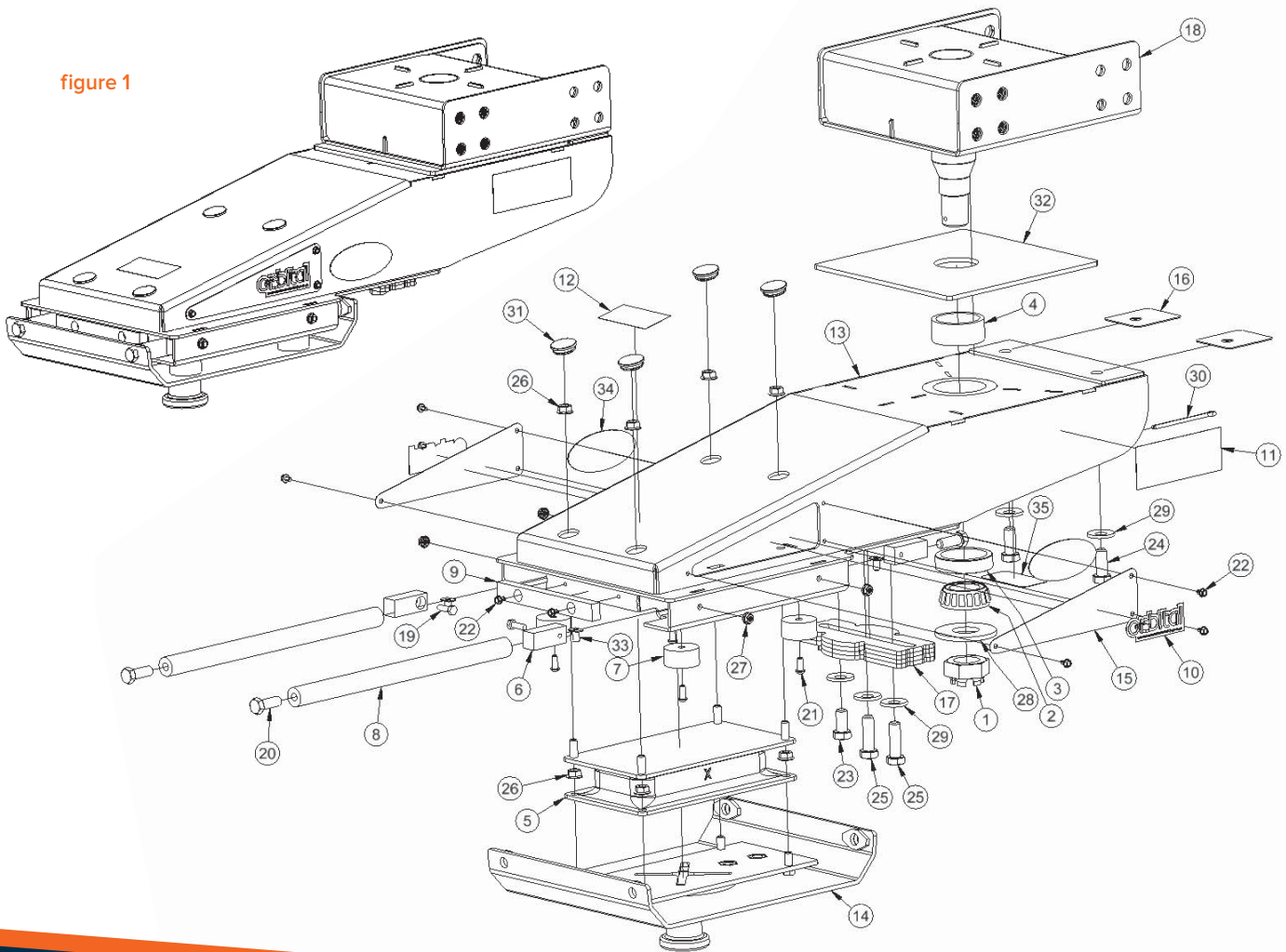

Above. Beyond. Always.

## PREPARATION

### Product and Safety Information

The MORryde Orbital Rotating Rubber Pin Box is designed for 5th wheel trailer application only. The Orbital Rotating Rubber Pin Box can be locked out for use as a standard, non-rotating pin box. Used in rotation mode, the Orbital Rotating Rubber Pin Box has the ability to achieve more than 90° of stress-free turning in either direction with over 180° of total turning possible.

**⚠ WARNING** Failure to follow the instructions and heed the warnings of this manual may result in death or serious injury, damage to the vehicle and/or trailer, and/or voidance of the product warranty. Always utilize appropriate safety equipment, i.e. proper eye protection, hearing protection, gloves, etc.

### Tow Rating Checks

**⚠ WARNING** Failure to verify and follow tow ratings may result in damage to the tow vehicle or separation of the truck and trailer during transit. The trailer and its contents must not exceed truck, hitch, and/or trailer tow ratings.

#### Do NOT Exceed

- Towing vehicle manufacturer's rating
- Max Gross Trailer Weight of 16,000 lbs
- Trailer manufacturer's rating
- Max Pin Weight of 4,000 lbs

**NOTE:** The Orbital Rotating Rubber Pin Box's pin weight is designed for a maximum load of 25% of the gross trailer weight or 4,000 lbs.

### Use of Manual

Dealer

- Provide Manual to end user

End User

- Read and follow Manual with each use of the Orbital Rotating Rubber Pin Box
- Save Manual for future reference
- Provide Manual to other users or future owners of the Orbital Rotating Rubber Pin Box

**⚠ WARNING** Failure to follow all of these instructions may result in serious injury or death.

### Torque Specifications

LOCATION	BOLTS		TORQUE VALUE
	(GR5)	(GR8)	
Attaches upper mounting column to skid pad		7/16-14	55 ft-lbs.
Retainment Rods	9/16-12		90 ft-lbs.
Attaches spindle box to trailer frame	5/8-11		135 ft-lbs.
Wedge and Lockout		5/8-18	200 ft-lbs.

**NOTE:** • The 5/16-18 buttonhead bolt that attaches the glide disc to the upper mounting assembly should be hand-tightened so that the bolt head begins to sink into the plastic. Prior to installation, a drop of blue Loctite should also be applied to the threads on the end of this bolt.

- The torque value of the 1 ½ - 12 castle nut that holds the pin box on the spindle is 80 ft-lbs. If the opening of the nut does not line up with the hole in the spindle, tighten the castle nut further until the cotter pin can be installed.
- Tighten each 5/16-18 serrated flange nut that holds the plastic blocks in place until secure.

## PREPARATION

### Cab Clearance Check

figure 2

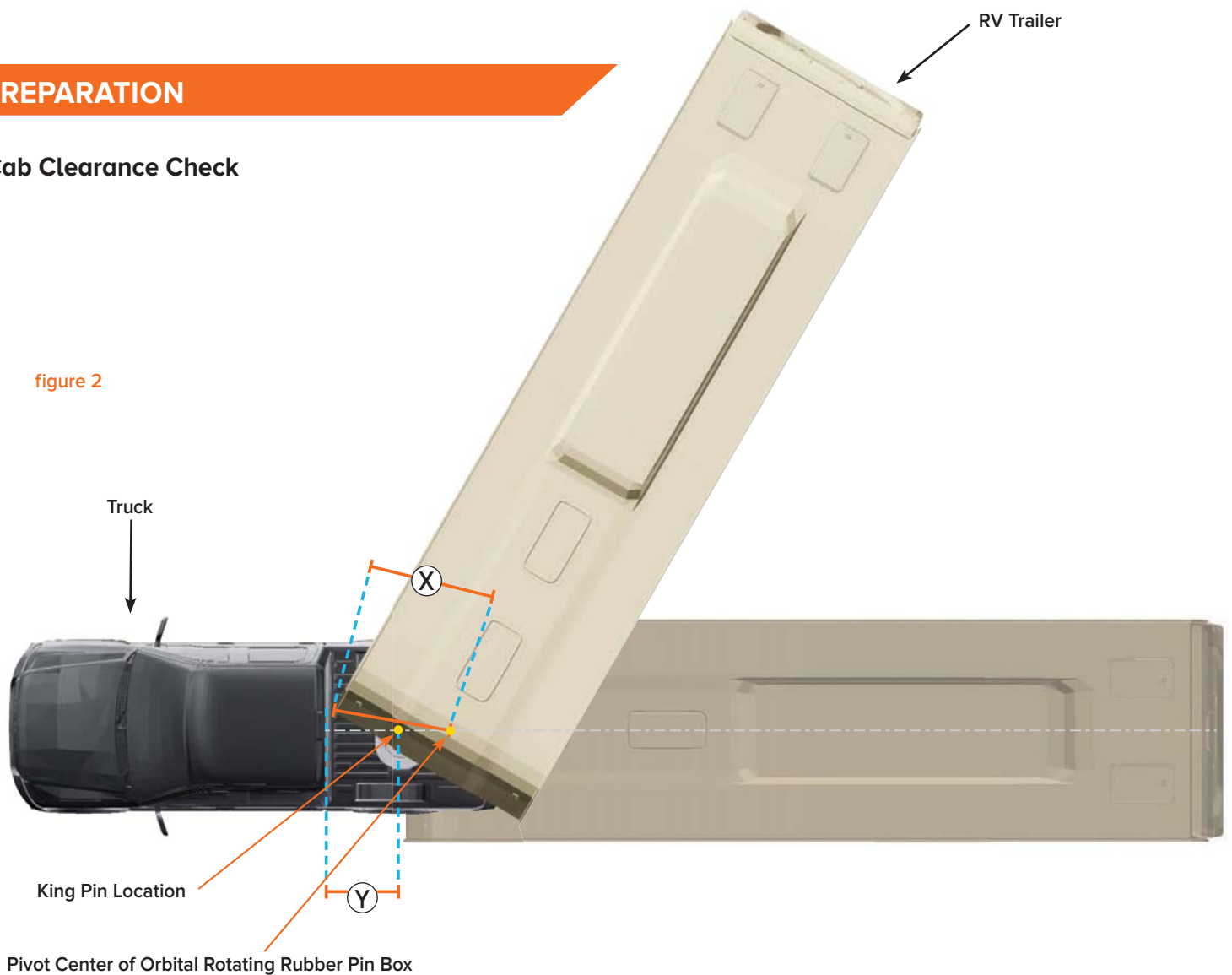

**STEP 1** Measure *Distance X*: Pivot center of Orbital Rotating Rubber Pin Box to the farthest point on coach front cap.

**STEP 2** Measure *Distance Y*: King pin location to the rear of the truck cab.

**STEP 3** If  $Distance Y + 25"$  is greater than or equal to *Distance X*, it is possible to turn up to  $90^{\circ}$  or more in Rear Rotation Transport mode.

**⚠ WARNING** After taking the above measurements, the viability of the truck / trailer combination should be double-checked after the installation of the pin box by making a turn in a controlled environment such as a parking lot or grass field. An observer should watch for any interference between the truck and trailer.



Above. Beyond. Always.

## Bumper Clearance Check

figure 3

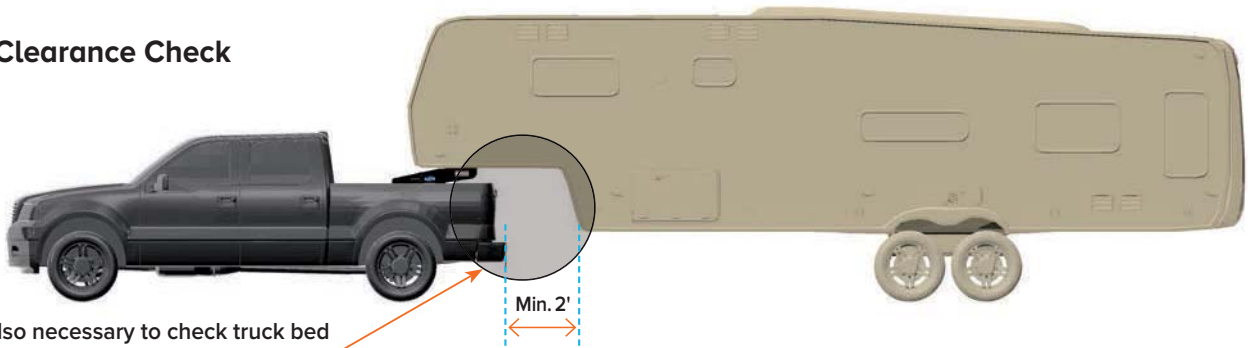

It is also necessary to check truck bed to RV trailer clearance in this area.

**⚠ WARNING** The Orbital Rotating Rubber Pin Box requires a minimum 2' clearance between the bumper and the trailer when measuring both at the same height. If the clearance is less than 2', the viability of the truck / trailer combination can be checked after the installation of the pin box by making a turn in a controlled environment such as a parking lot or grass field. An observer should watch for any interference between the truck and trailer.

**STEP 1** Adjust the height of the hitch and pin box so the trailer is level when towed.

figure 4

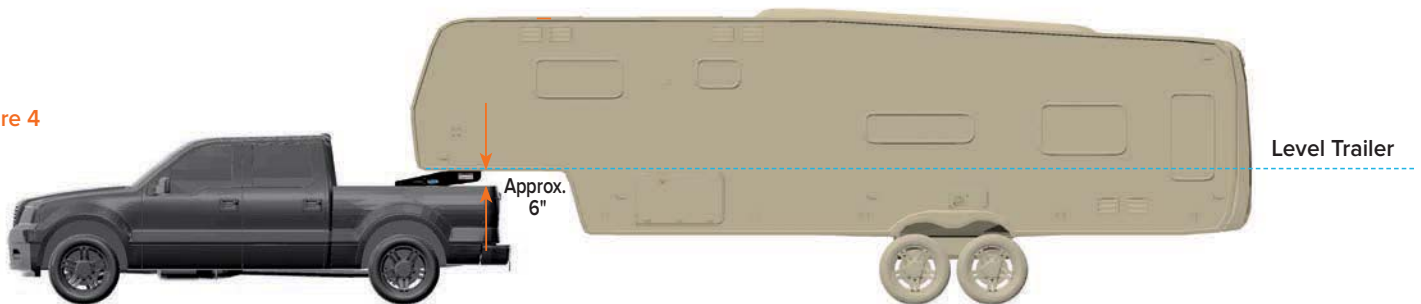

**STEP 2** 6" of clearance is required between the top of the bed and the underside of the front of the trailer to allow for the pitch and yaw of the trailer (see figure 4).

**STEP 3** Off-road use requires more than 6" of clearance between the walls of the pickup and the trailer.

**⚠ WARNING** The measurements in figures 2, 3, and 4 are intended to be used as guidelines. If your measurements are approaching these numbers, double-check your clearances. If the truck and/or trailer have any additional bed accessories such as fairings, air dams, ground effects, bed rails, etc., perform further dimensioning and clearance checks. MORryde is not responsible for damage incurred when disregarding these clearance checks or the double checks when taking a slow turn with an observer watching.

**⚠ WARNING** Be sure to check the compatibility of your 5th wheel hitch with the Orbital Rotating Rubber Pin Box. See page 13 or contact MORryde's Parts Department at 574-293-1581.

**⚠ WARNING** Avoid positioning any part of your body under the trailer or between the tow vehicle and trailer. Unintended movement of the tow vehicle or trailer may result in serious injury or death.

In the event that you must place part of your body under the trailer or between the truck and trailer, you **MUST** complete **ALL** of the following steps:

- Put the truck transmission in park.
- Set the truck emergency brake.
- Place blocks in front of and behind all trailer tires.
- Deploy and ensure that the trailer's landing gear rests firmly on the ground.

## OPERATING INSTRUCTIONS

### Standard Transport

**⚠ WARNING** Never operate the Orbital Rotating Rubber Pin Box without a wedge unless the lockout bolts have been installed as this creates double pivot points. Death or serious injury and/or damage to the tow vehicle and trailer may result. In addition, never operate the Orbital Rotating Rubber Pin Box with both the lockout bolts and the wedge installed as this will damage the hitch and/or other property.

To use the Orbital Rotating Rubber Pin Box as a standard, non-rotating pin box, install the (2) 5/8" GR 8 lockout bolts and mounting hardware in the back of the unit as shown in figure 5. These bolts prevent rotation and allow use of the Orbital Rotating Rubber Pin Box without installation of the wedge. For OEM applications, these bolts are installed at the factory and may or may not have been removed at the dealer.

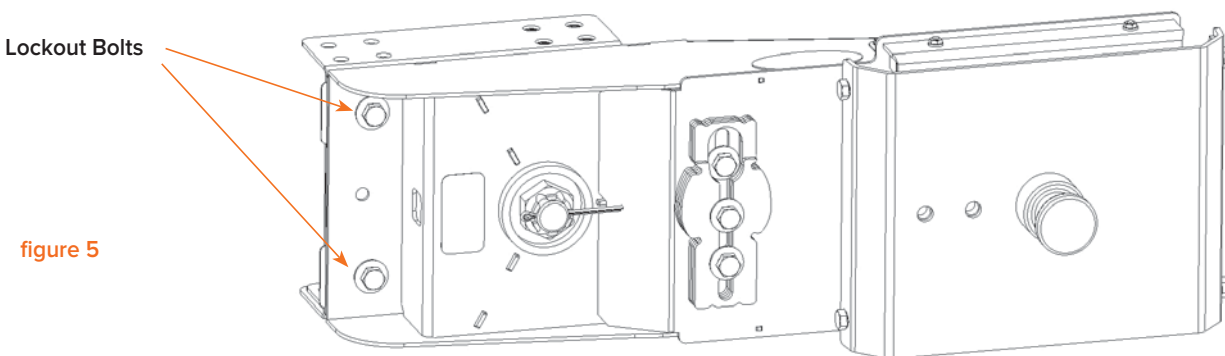

### Rear Rotation Transport

**⚠ WARNING** Do not install a wedge unless the lockout bolts have first been removed.

The Orbital Rotating Rubber Pin Box's rear rotation has the ability to achieve more than 90° of stress-free turning in either direction with over 180° of total turning possible. This is accomplished through the installation of a wedge to lock the pin box at the tow vehicle's hitch, transferring the pivot point from the truck bed to the mounting wings of the pin box under the nose of the trailer. **NOTE:** Not all tow vehicle / trailer combinations reach the full 180°.



Above. Beyond. Always.



## WEDGE INSTALLATION

**Tools Required:** 15/16" wrench • White lithium grease • Torque wrench • 15/16" socket, ratchet

### STEP 1

Verify the part number of the wedge you have received with the shipping paperwork. Also double check that this is the wedge intended for your 5th wheel hitch, or that it is the universal wedge. Refer to the Wedge Guide on page 10 for more information.

### STEP 2

Remove the (2) 5/8" lockout bolts, conical washers, and rectangular spacer plates from the rear of the pin box as shown in figure 6a.

### STEP 3

Remove the wedge from the wedge storage location (shown in figure 6a) by removing (3) 5/8" bolts and lock washers. You will use 2 of the 3 bolts as determined in Step 4. Store the lockout hardware in the lockout storage location shown in figure 6b.

figure 6a

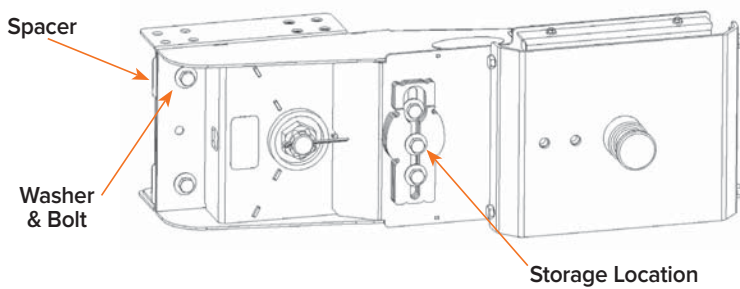
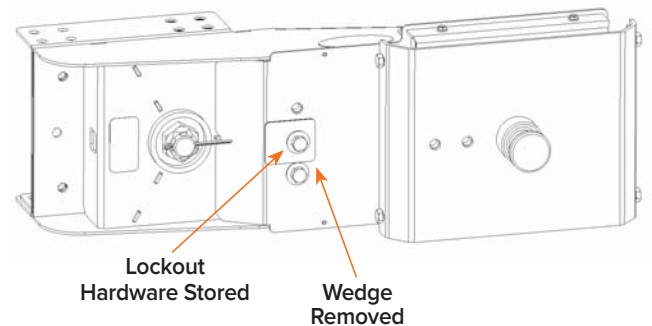

figure 6b



### STEP 4

Determine the best orientation for your hitch by reviewing the diagrams in figure 7.

figure 7

Orientation for Reese/Draw-Tite/Hidden Hitch Select Series, Pro Series, Husky and similar style 5th wheel hitch heads.

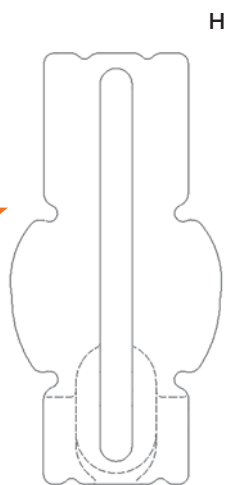

In this orientation, use the (2) 2" long bolts.

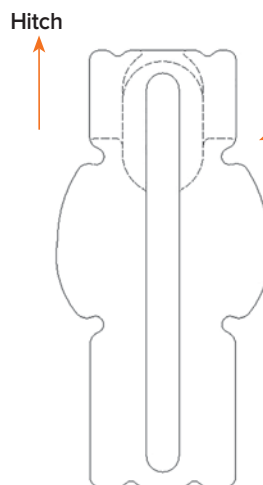

In this orientation, use (1) 2" long bolt and (1) 1 1/4" bolt.

Orientation for Reese/Draw-Tite/Hidden Hitch Signature Series and Select Plus, Reese Titan 16K and 20K, B&W and similar style 5th wheel hitch heads.

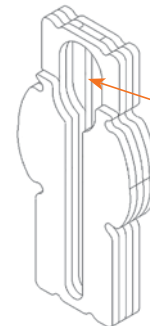

Relief must face down for these applications in order to clear the jaw.

## WEDGE INSTALLATION

### STEP 5

Using the orientation for your hitch determined in Step 4, place the wedge into position (see figure 8). Do not fully tighten the bolts. Rather, tighten the (2) 5/8" wedge bolts until the lock washers just engage. The wedge should still slide with the tap of a hammer. Place the remaining wedge storage bolt and washer back in the storage location.

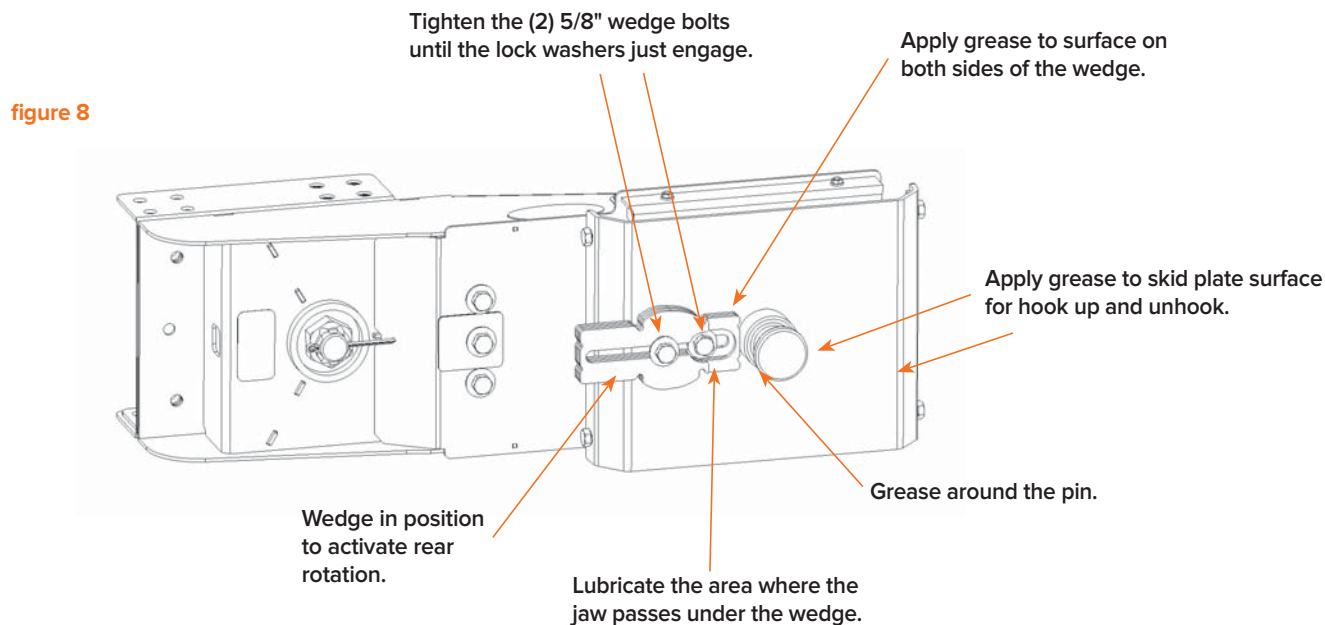

### STEP 6

It may be necessary to apply grease to the surface of both sides of the wedge, the king pin, and the surface of the skid plate as shown in figure 8.

### STEP 7

Backing up straight in line with the Orbital Rotating Rubber Pin Box, hook the tow vehicle to the trailer. Verify that the jaws of the hitch close properly. Refer to the owner's manual of your 5th wheel hitch for proper latching of the hitch.

### STEP 8

**⚠ WARNING** Be sure that the trailer wheels are securely blocked, the landing gear rests firmly on the ground and supports the weight of the trailer, and the truck is stationary and in the park with the emergency brake applied before proceeding.

Tap the wedge until it no longer moves forward. Ensure that the wedge contacts both sides of the funnel area of the hitch. **NOTE:** If it does not, release the tow vehicle's emergency brake, remove the wheel blocks, and raise the trailer's landing gear. Pull the trailer forward slightly to straighten the truck hitch and pin box. Come to a stop by first applying the trailer brakes followed by the truck brakes. Reset the emergency brake and landing gear, and reblock the wheels of the trailer. Once the wedge no longer moves forward AND also makes contact with both sides of the funnel area of the hitch, torque the bolts to 200 ft-lbs. If it is not possible to torque the bolts to the full 200 ft-lbs while the pin box is engaged in the hitch, tighten them as much as possible, unhitch, and then torque the bolts to spec.



Above. Beyond. Always.

## WEDGE GUIDE

This guide displays the wedges MORryde produces for specific 5th wheel hitches. While the wedges below provide an optimal fit for the variations in each manufacturer's hitch design, the Universal Wedge that comes with your Orbital Rotating Rubber Pin Box may still be used in most applications.

RTPB77-004  
HUSKY

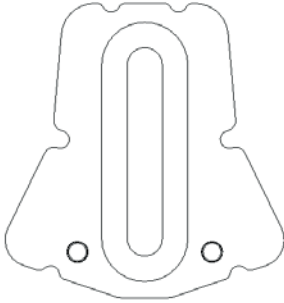

RTPB77-005  
HIJACKER

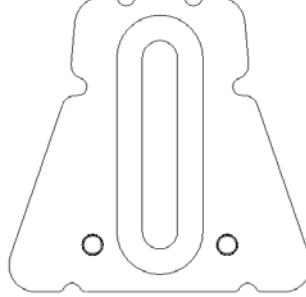

RTPB77-006  
PRO SERIES

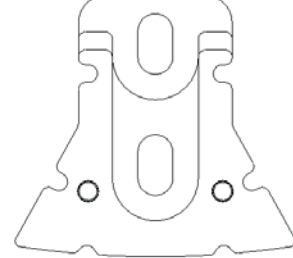

RTPB77-007  
B & W

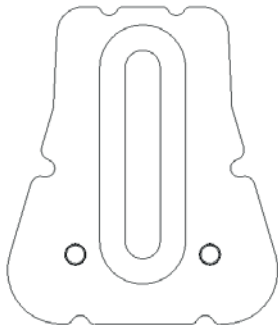

RTPB77-008  
TITAN SERIES

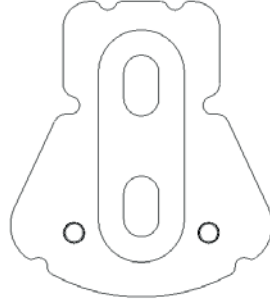

RTPB77-009  
SELECT SERIES

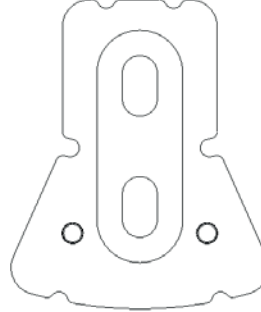

RTPB77-010  
SIGNATURE SERIES

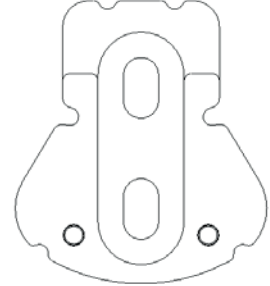

RTPB77-011  
PULLRITE

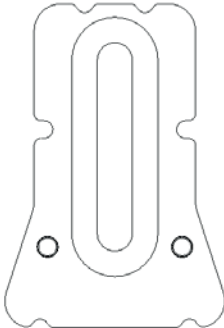

RTPB77-012  
COLIBERT

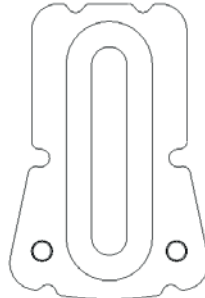

RTPB77-013  
CURT A SERIES

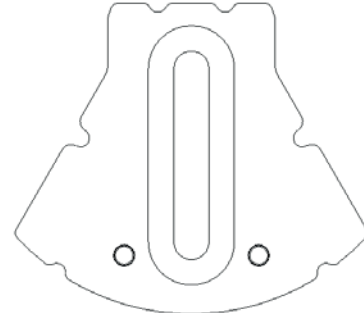

## HITCHING INSTRUCTIONS

### Procedure

**⚠ WARNING** Failure to follow these instructions may result in serious injury or death. **NOTE:** You are responsible for safe hitching and unhitching of the tow vehicle and trailer. Personally verify that the following steps are performed in the order described below.

#### STEP 1

Firmly block the front and rear of each trailer wheel to prevent any forward or rearward movement. It may be necessary to lower the tailgate of the tow vehicle, but clearance between the lowered tailgate and trailer must then be monitored during the hitching procedure.

#### STEP 2

Following the trailer manufacturer's instructions, adjust the height of the trailer so that the bottom of the pin box is 1/2" to 1" below the skid plate (see figure 9). **NOTE:** During the hitching process, the bottom of the pin box should come into contact with the skid plate ramp.

#### STEP 3

Refer to your hitch manufacturer's manual for the remaining instructions on safe and proper hook up.

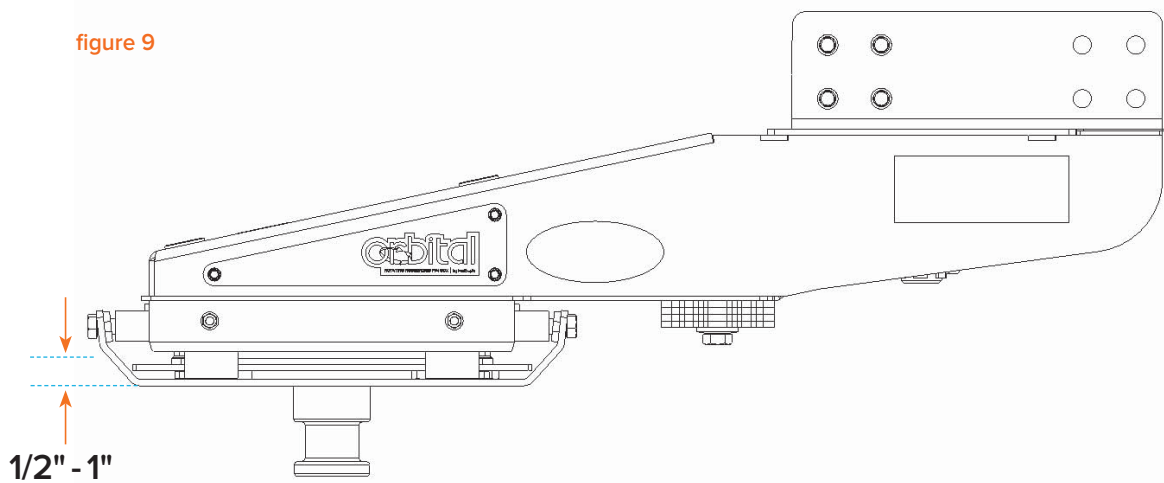

**NOTE:** The tow vehicle and trailer must be in line for the wedge to enter the 5th wheel funnel. There should be no space between the bottom surface of the pin box and the top surface of the hitch. If there is space, do not tow the trailer as it has not been properly hitched. Instead, repeat the steps of the Hitching Procedure and recheck.

**⚠ WARNING** Neglecting to follow these instructions may cause improper hook up. If the king pin is too high, it may rest on the closed jaws of the hitch or fail to sit completely inside the jaws, resulting in separation of the tow vehicle and trailer and lead to serious injury or death.



Above. Beyond. Always.

## Pull Test

**⚠ WARNING** Failure to perform the pull test may result in property damage, serious injury, or death. Failure to keep the trailer wheels blocked and the landing gear down may result in sudden forward movement or falling of the trailer and lead to property damage, serious injury, or death.

### STEP 1

Firmly block all trailer wheels.

### STEP 2

Support the weight of the trailer with landing gear resting firmly on the ground.

### STEP 3

Set the transmission of the tow vehicle to park and apply the emergency brake.

### STEP 4

Ensure no one is between the tow vehicle and trailer.

### STEP 5

Return to the cab and release the emergency brake of the tow vehicle. **Apply the trailer brakes**, attempting to slowly pull the trailer forward with the tow vehicle. If the trailer is properly hitched, the trailer wheel blocks and trailer brakes should keep the tow vehicle from moving forward.

**NOTE:** If the trailer is not properly hitched, the trailer will separate from the hitch and the tow vehicle will pull forward without the trailer. Following **ALL** of the precautionary steps above will prevent the trailer from dropping and/or falling.

### STEP 6

After completing a successful Pull Test, fully raise the landing gear of the trailer in accordance to the trailer's manual.

### STEP 7

Inspect all electrical circuits for operation, i.e. clearance lights, turn signals, brake lights, etc.

### STEP 8

Remove and store all trailer wheel blocks.

## COMPATIBILITY

### Your MORryde Pin Box System is compatible with:

- PullRite® SuperGlide
  - Since the rotation will occur in the 5th wheel hitch, the lockout bolts need to be in place and the proper PullRite wedge needs to be installed.
- Lube Disc
  - In Standard Transport mode only.

### Your MORryde Pin Box System is not compatible with:

- Gooseneck adaptors

## PRE-TRAVEL INSPECTION

- Inspect the condition of all towing equipment. Make any repairs or replacements necessary.
- Inspect the condition and torque of all bolts.
- Inspect the wedge engagement in the jaw of the 5th wheel hitch. Adjust according to the instructions on page 8.

## MAINTENANCE

- If using the Orbital Rotating Rubber Pin Box in the rear rotational mode, be sure to periodically grease the wedge and skid plate surfaces and around the king pin. Apply grease to the grease zerk at the back of the pin box as well as the bearing surfaces as described on page 9. **NOTE:** Resistance is normal in the arm (see figure 10) of the Orbital Rotating Rubber Pin Box.
- Repaint pin box to prevent rust and maintain its appearance. **NOTE:** Do **NOT** paint over labels.
- Annually inspect king pin for excessive wear.
- Inspect the skid pad to ensure a neutral (centered) position. When the trailer is disconnected from the tow vehicle, an equal gap of approximately 1- 1/4" should be observed between the lip of the skid pad and the rubber compression bumpers. It is normal to slightly move and twist the skid pad assembly with hand force.
- Inspect the retainment rods for excessive wear. The retainment rods may show surface scratch marks as an indication of occasional contact but the scratches, if present, should be minimal.
- Inspect the plastic glide discs for excessive wear. The glide disc thickness should be no less than 3/4".
- Periodically check the torque values of all hardware. Torque specifications have been provided on page 4 of this manual.

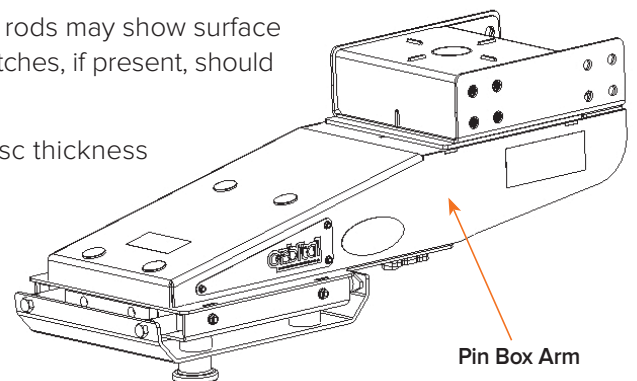
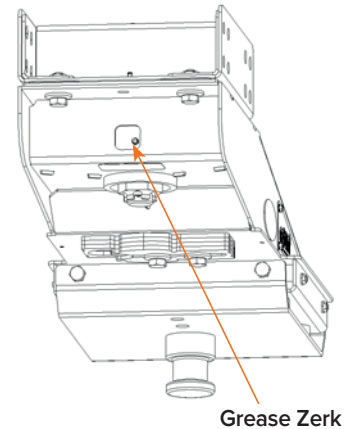

figure 10



Above. Beyond. Always.

PROBLEM	REMEDY
<b>Trailer not level.</b>	Adjust pin box or hitch accordingly.
<b>Excessive bottoming of skid pad assembly. Jerky ride in tow vehicle.</b>	Ensure that trailer is level. Inspect to ensure that the rubber compression bumpers are in place. Check trailer brakes for proper operation. If the above is satisfactory, it may be necessary to install a shear spring with a different spring rate. Contact MORryde's Parts Department for assistance; they will require your actual trailer weight to assist.
<b>Skid pad assembly does not return to neutral position when disconnected from tow vehicle.</b>	Check for loose or torn rubber shear spring.
<b>Excessive noise from pin box area.</b>	Verify that the pin box is securely attached to the 5th wheel. If the king pin is excessively worn, the skid pad will need to be replaced. Hitch mechanisms can also cause noise. Verify that unwanted noise is not coming from the hitch. Your hitch manufacturer can provide guidelines for this check.



At MORryde, we have a passion for solving problems. Whether we're fabricating custom solutions, modifying a commercial chassis, or creating our innovative products, we answer to a wide range of markets and deliver on a variety of needs. At MORryde, it's simply about doing MORE for our customers, and it doesn't stop at the sale. We stand behind our products, believing in quality first, service always. No matter the issue, we'll be the first to respond and the last to be satisfied. In short, we build better — together.



Above. Beyond. Always.