



63823 Ford Combination Vacuum Pump/Alternator Mount

This kit is engineered to mount a Moroso enhanced style vacuum pump (22642) and a Nippon Denso 93MM alternator to a Ford small block engine equipped with a **CSR** electric water pump. It will **not** work with other water pumps, vacuum pumps or larger alternators. Take a few moments to unpack the contents of the kit and familiarize yourself with its components. Read the instructions through completely before attempting installation.

Mounting the Plate. The plate is attached to the engine using the mounting bolts for the two legs of the water pump that fasten to the pump's main body (see illustration). Remove the original socket cap screws and install the two adapter brackets using the longer 1 ¼" socket cap screws provided. Tighten the cap screw finger tight. Mount the pump to the engine and tighten up all the cap screws evenly. Mount the Alternator/Vacuum Pump Plate to the adapter brackets using the shorter cap screws and lock nuts provided.

Mounting the Vacuum Pump. Insert the vacuum pump through the back of the plate. The pump should go into the plate with only a slight press and should rotate freely without the pinch clamp bolt. Install the vacuum pump pulley (Moroso part 64885 or 64887). Belt tensioning is accomplished by rotating the pump. Using the recommended 2 1/2" drive pulley, a 5" pump pulley, and a 1/2" X 30 1/2" V-belt, correct tension will occur with the inlet and outlet ports at 7:00 and 11:00 o'clock on the pump. Complete the installation by tightening up the ¼-20 pinch-clamp cap screw. Use anti-seize compound on the threads.

Mounting the Alternator. Using one each of the two low-head 3/8 cap screws and lock nuts, hang the alternator from the large mounting foot to the uppermost hole in the bracket. Assemble the adjusting link and bolt it up to the lower mounting hole in the bracket, using the second low-head cap screw, lock nut and, aluminum spacer provided. The lower hole in the alternator is typically tapped for an 8MM bolt and we have provided a bolt and washer for this. We recommend, however, that the lower hole be drilled out and tapped for a 3/8-16 fastener for a better installation. Make certain that all vent holes in the alternator are masked to prevent chips from entering the housing during this procedure and make every effort to ensure proper alignment. Using a 4.000" V-belt drive pulley (Moroso part 23523) and the original alternator pulley, install a 1/2" X 28" belt for a proper fit.

Notes

- Belt lengths were determined using industry standard “4L” or “A” cross-sections. Other belt sections will work. For example, a belt with a section width of .410 will fit the pulleys however the outer diameter will be less.
- Depending on the location of the water pump inlet, it may be necessary to use a reduced diameter fitting or a short length of straight pipe for clearance.
- The use of an anti-seize compound is recommended on all aluminum threads.

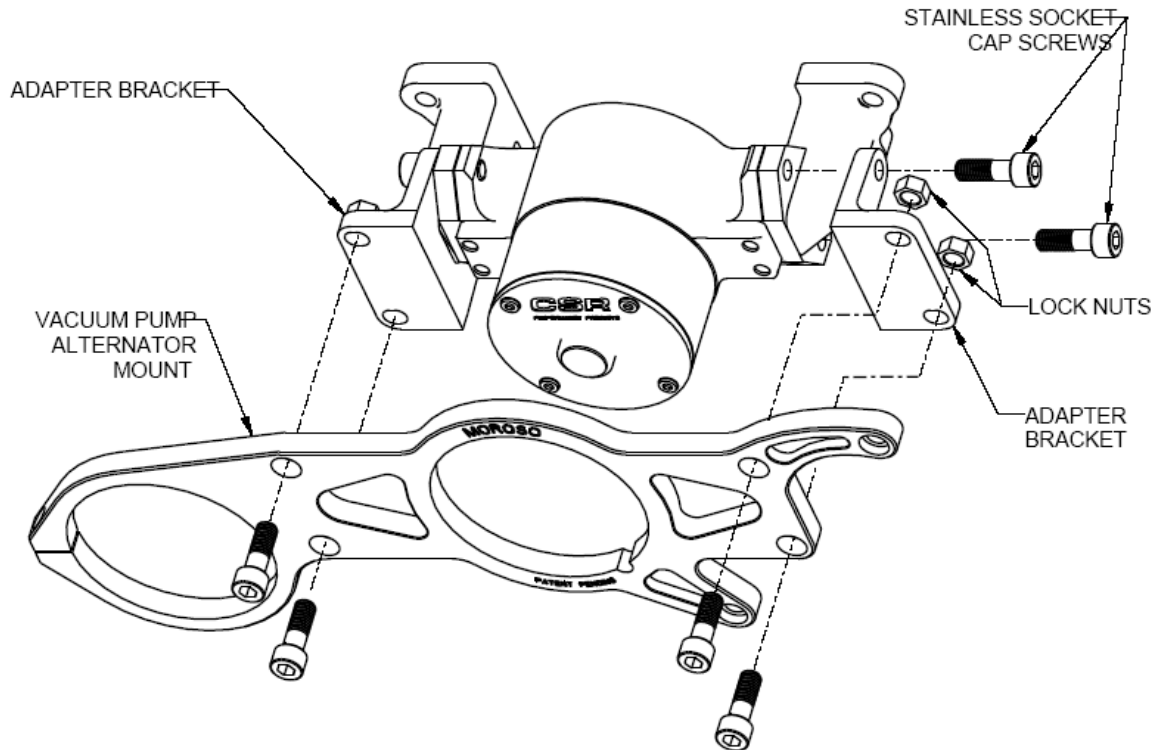

Parts List

- | | |
|-----------------------------|--|
| (1) ALT./VACUUM PUMP MOUNT, | (2) 3/8IN. X 2.000 LOW HEAD CAP SCREWS |
| (1) ALTERNATOR TURNBUCKLE | (1) 3/8IN. ROD END & JAM NUT, LEFT |
| (8) 3/8IN.X 1.250 SST SHCS | (1) 3/8IN. ROD END & JAM NUT, RIGHT |
| (4) 3/8IN.X 1.000 SHCS | (1) ALUMINUM SPACER |
| (2) 3/8IN.X 1-3/4IN. SHCS | (1) 8MM X 1.25 X 30MM HHCS |
| (1) WASHER 5/16IN. FLAT | (3) 3/8 WASHER |
| (7) 3/8 NYLON LOCK NUTS | (1) 1/4IN.X 3/4IN. SHCS |
| (2) ADAPTER BRACKETS | (1) 3/8IN.X 1.250 SHCS |

63823INS

040511