



63822 Ford Combination Vacuum Pump/Alternator Mount

This kit is engineered to mount a Moroso enhanced style vacuum pump (22642) and a Nippon Denso 93MM alternator to a Ford small block engine equipped with a **Moroso 63585** electric water pump (standard rotation). It will **not** work with other water pumps, vacuum pumps, larger alternators or, with timing covers for reverse rotation pumps. Take a few moments to unpack the contents of the kit and familiarize yourself with its components, (refer to the Parts List illustration). Read the instructions through completely before attempting installation.

Mounting the Plate. The plate is attached to the engine using the water pump mounting bolt locations shown in the accompanying illustration. Six water pump mounting bolts are to be replaced with two 4.000" long studs and four 2.000" studs. Use the assembly diagram for locations. Thread all studs into the block, or timing cover, with the short threads facing in and the long threads facing out. A removable thread-locking compound can be used here. Once the studs are in place, install the water pump. Use the six aluminum threaded standoffs to mount the water pump to the studs. The hex on the standoffs should face outward. Use a small amount of anti-seize compound on the aluminum threads and install all standoffs finger tight. Apply a small amount of anti-seize compound to the threads of the 5/16 socket cap screws and mount up the Vacuum Pump / Alternator plate to the six standoffs, hand tight. Tighten up all standoffs first, and then tighten the socket head cap screws to complete the mounting of the plate.

Mounting the Vacuum Pump. Insert the vacuum pump through the back of the plate. The pump should go into the plate with only a slight press and should rotate freely without the pinch clamp bolt. Install the vacuum pump pulley (Moroso part 64885 or 64887). Belt tensioning is accomplished by rotating the pump. Using the recommended 2 1/2" drive pulley, a 5" pump pulley, and a 4L333, (1/2" X 33 1/4"), V-belt, correct tension will occur with the inlet and outlet ports at 7:00 and 11:00 o'clock on the pump. Complete the installation by tightening up the 1/4-20 pinch-clamp cap screw. Use anti-seize compound on the threads.

Mounting the Alternator. Using one each of the two low-head 3/8 cap screws and lock nuts, hang the alternator from the large mounting foot to the uppermost hole in the bracket. Assemble the adjusting link and bolt it up to the lower mounting hole in the bracket, using the second low-head cap screw, lock nut and, aluminum spacer provided. The lower hole in the alternator is typically tapped for an 8MM bolt and we have provided a bolt and washer for this. We recommend, however, that the lower hole be drilled out and tapped for a 3/8-16 fastener for a better installation. Make certain that all vent holes in the alternator are masked to prevent chips from entering the housing during this procedure and make every effort to ensure proper alignment. Using a 4.000" V-belt drive pulley (Moroso part 23523) and the original alternator pulley, install a 4L295, (1/2" X 29 1/2") belt for a proper fit.

ASSEMBLY DIAGRAM

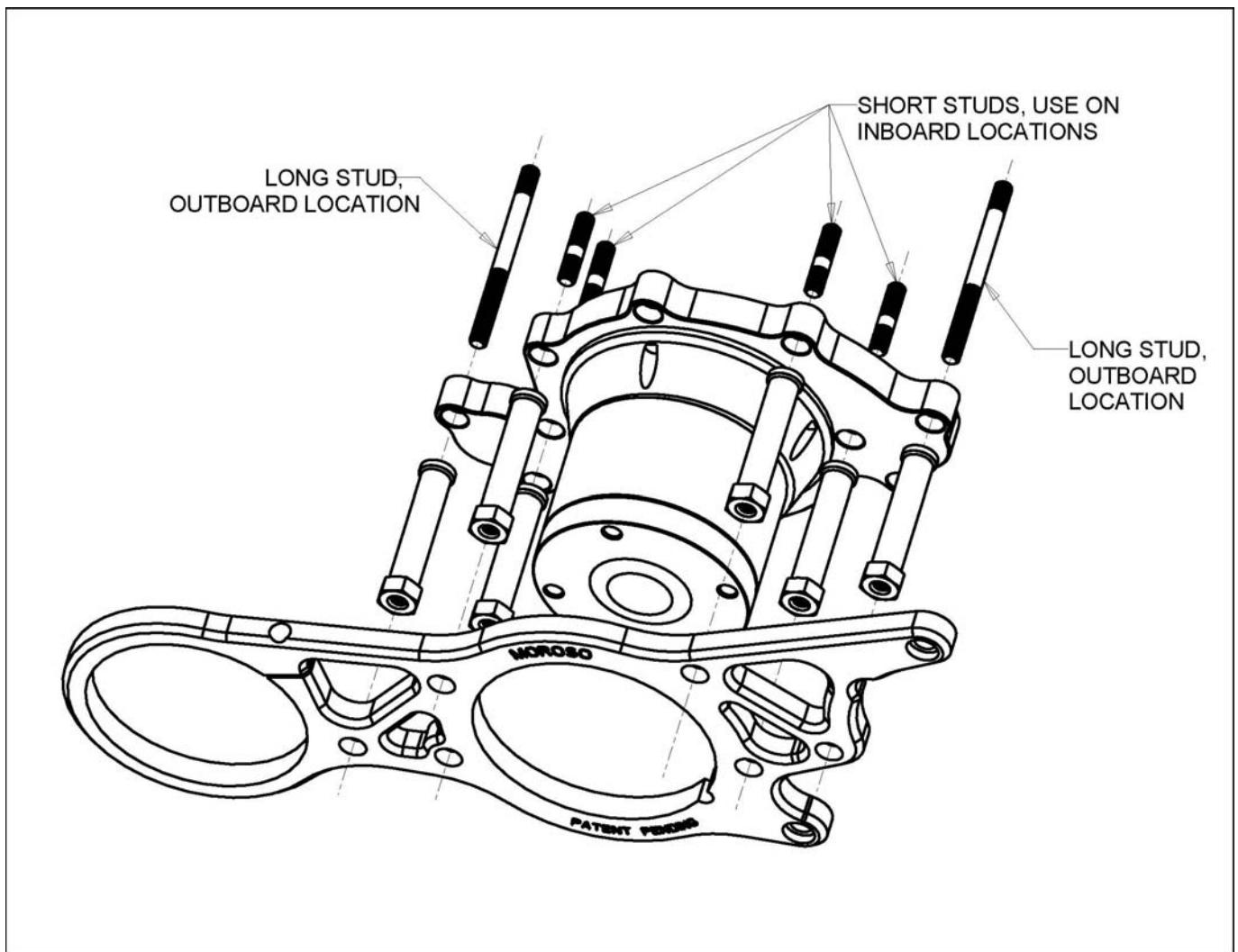

Notes

- Belt lengths were determined using industry standard "4L" or "A" cross-sections. Other belt sections will work. For example, a belt with a section width of .410 will fit the pulleys however the outer diameter will be less.
- The standoffs were machined with an 11/16" hex. This is the same size as a -6AN fitting wrench. Using aluminum fitting wrenches will help preserve the finish on the standoffs.
- Depending on the location of the water pump inlet, it may be necessary to use a reduced diameter fitting or a short length of straight pipe for clearance.
- The use of an anti-seize compound is recommended on all aluminum threads.

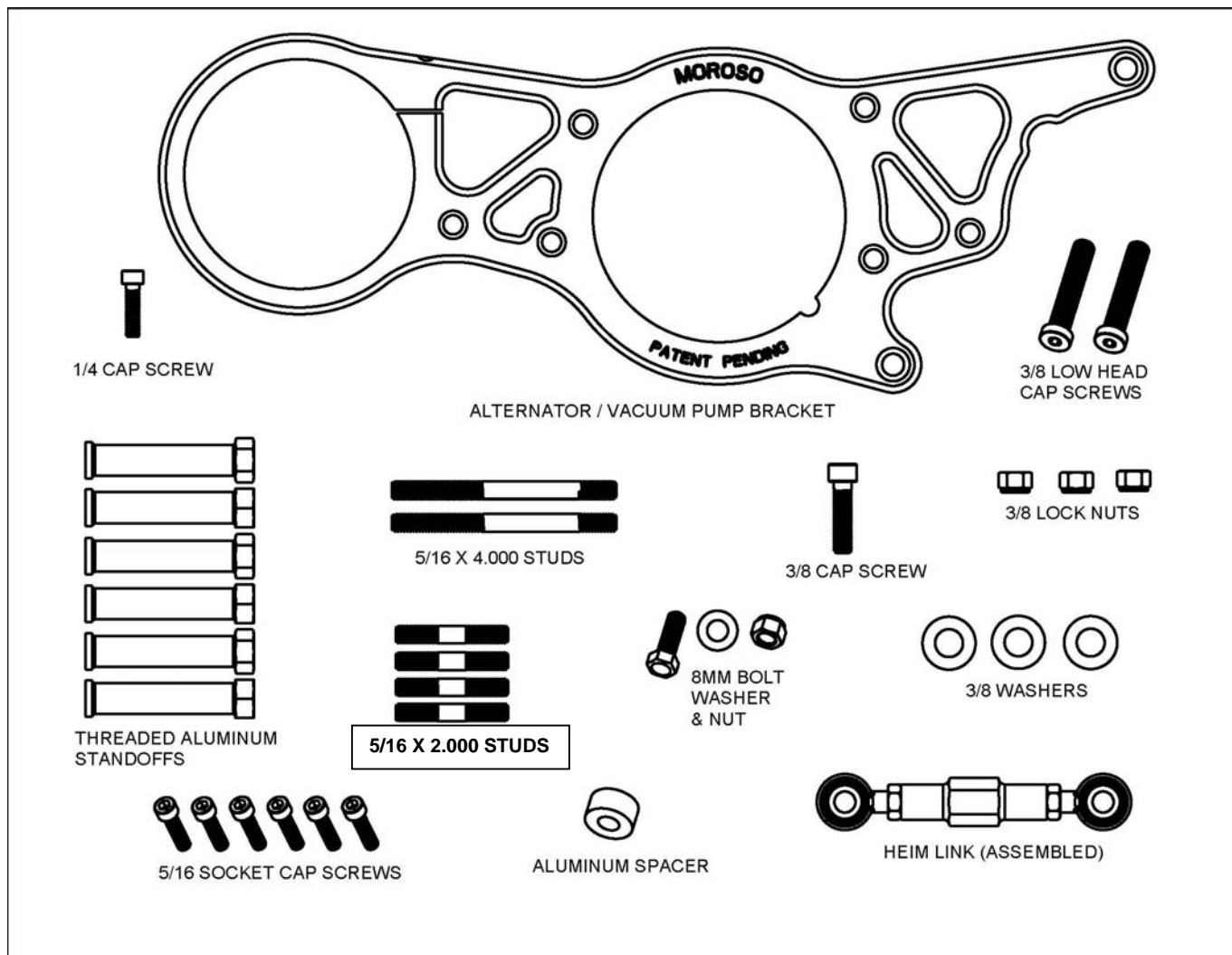

Related Moroso Components.

- 65853 - SB Ford Drive Mandrel Kit
- 63846 - SB Ford Drive Mandrel Kit
- 22842 - Vacuum Pump, 4-vane
- 22644 - Vacuum Pump, 4-vane-unplated
- 22840 - Vacuum Pump, 3-vane
- 64885 - Vacuum Pump Pulley
- 64887 - Vacuum Pump Pulley, Offset
- 64886 - Vacuum Pump Pulley, 28 tooth Gilmer
- 64888 - Vacuum Pump Pulley, 36 tooth Gilmer
- 23540 - Vacuum Pump Pulley, Radius Tooth