



**ELECTRIC WATER PUMP
BIG BLOCK MOPAR
P/N 63575**

INSTALLATION INSTRUCTIONS

These instructions are a basic guideline for installing a Moroso Performance Electric Water Pump. Always consult the proper manufacturer service manual for your vehicle for any general assembly/disassembly information.

The stock accessories (power steering pump, alternator, etc.) may have to be relocated in some cases to ensure clearance between belts, hoses, etc. and the water pump. This pump was designed to fit in the stock location on the engine. Use the supplied hardware and a high quality gasket sealer to prevent leaks.

CAUTION: Seal failure will occur if pump is operated without water or coolant in the system or the pump.

Incorrect wiring of this pump will cause damage to the pump motor and/or your engine. The Red Wire is Positive and should be connected to a 12 to 16 Volt maximum system, with a 20 Amp fused source. The Black Wire is Negative and should be connected to a suitable ground such as the engine or chassis.

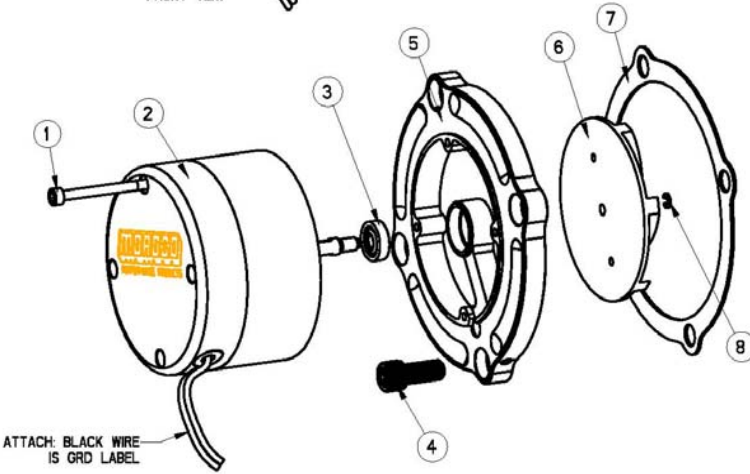
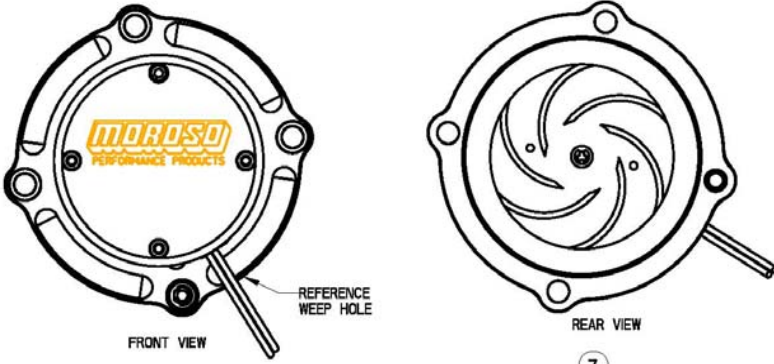

8	63765107	1	E-CIRCLIP
7	63575600	1	WTR PUMP GASKET
6	63575500	1	IMPELLER 6 VANE
5	63575162	1	W/P PLATE BBM
4	0506220	4	3/8-16 X .87 SHCS
3	63540130	1	WTR PUMP SEAL
2	63564751	1	MOTOR ASSEMBLY
1	63565815	4	10-24 X 2.62 SHCS
DETAIL	P/N	QTY	DESCRIPTION