



P/N 25900 CRANKCASE EVACUATION SYSTEM **DRAG RACE/ OVAL TRACK**

PART LIST

- | | |
|------------------------------|-------------------------|
| 1. Grommets (2) | 3. Check Valves (2) |
| 2. Breathers Evac System (2) | 4. Threaded Nipples (2) |

NOTE: The installation of all fittings as to placement with proper depths and angles is very Critical for proper operation of this system.

DRAG RACE APPLICATION

1. Remove valve covers and drill a 1-1/8" hole in each cover. On all Moroso "Stamped" Valve Covers, the holes provided will work perfectly. When determining hole location for all other covers, try to find a flat surface that is not directly over a rocker arm oil hole.

- NOTE:** Separators must be installed in a position at right angles to the top of the valve covers to function effectively. See Fig (1)
2. Before installing rubber grommets, remember to cut the bottom "seal area" off to allow the separator to work. Lubricate the inner surface of the grommet with a touch of oil or grease and twist in the separator. The fit should be tight to help hold crankcase vacuum.
 3. Drill a 7/8" hole in the right and left collector directly behind the transition area shown in figure (2). Check valve installs on the top of the collector.
 4. Place check valve probe at the proper depth and angle per drawing and weld all the way around for a complete seal.
 5. Use a 5/8" high heat or high pressure hose to complete installation. See Fig (3)

OVAL TRACK APPLICATION

1. Remove driver's side valve cover and drill two 1-1/8" holes in it. When determining hole locations, try to find a flat surface that is not directly over a rocker arm. See Fig (1)

See Note above:

2. Follow steps (2), (3) and (4) above.
3. Use a 5/8" heat resistant or high pressure hose to complete installation, See Fig (4)

NOTE: It is recommended that a baffle be fabricated to go on the inside of the valve cover directly under the oil separator to keep oil out of the separator as shown in figure (1). Moroso P/N 68790 can be used but may not clear some stud girdles.

Fig (1)

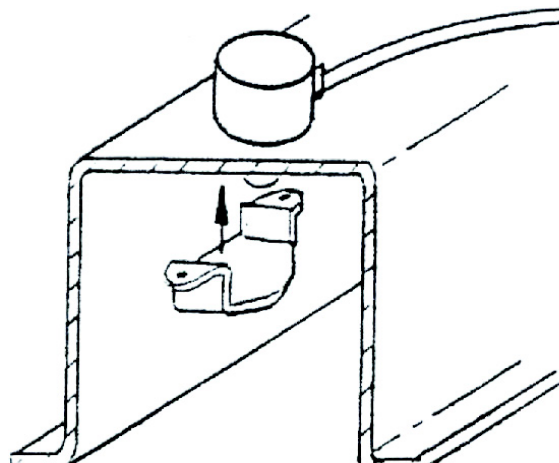

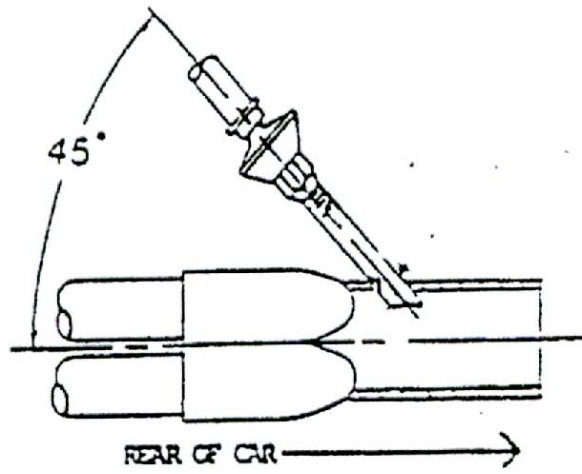

Fig (2)

DRAG RACE

OVAL TRACK RACING

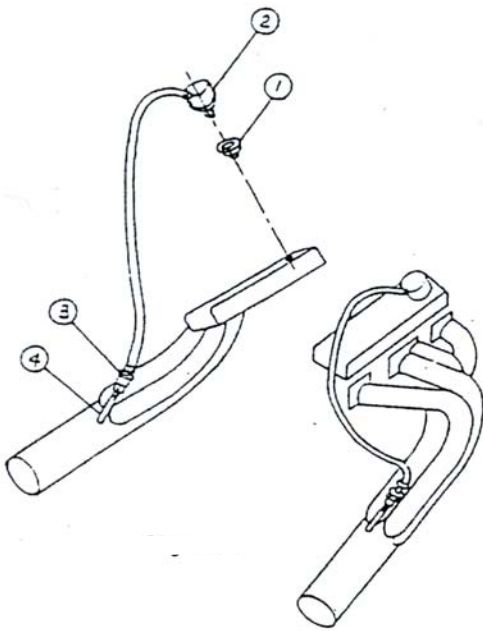

Fig (3)

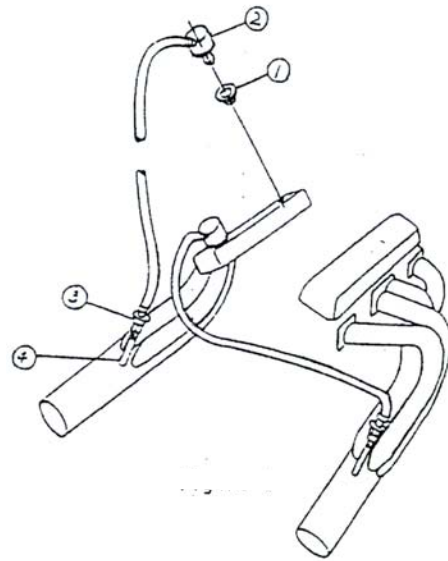

Fig (4)