



INSTALLATION INSTRUCTIONS P/N 63531

PARTS LIST

ITEM	DESCRIPTION	QTY.
A	5/16-18 HHCS	3
B	5/16 WASHER	3
C	5/16-18 RIVET NUT	3
D	3/8-16 HHCS	1
E	3/8 WASHER	1
F	3/8-16 RIVET NUT	1
Not Shown	Ball Valve 3/8 NPT	1
Not Shown	Bleed Valve	1

FRONT VIEW

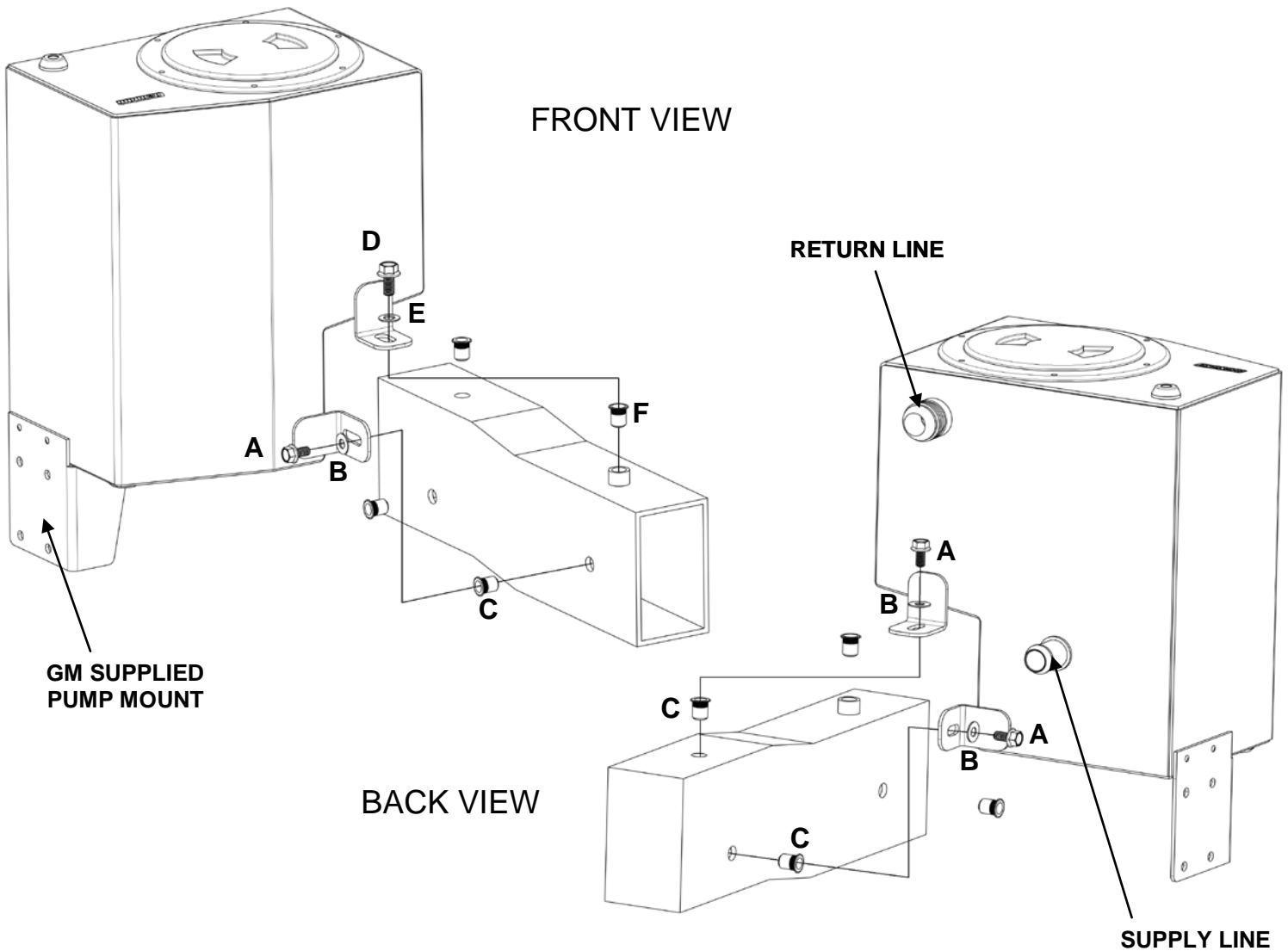

APPLICATION:

2010 and up Camaro SS and COPO Camaro without a tank

Installation

1. Locate the post protruding through the top of the frame rail next to the radiator.
2. Fit the tank so the center of the slot on the top front mounting tab aligns with the center of the post on the frame rail.
3. Mark the midpoint of each mounting tab slot on the frame rail. Then remove the tank.
4. Using a 17/32 drill bit, drill holes in the frame rail at the marked locations.

***NOTE:** Be careful to drill a clean, round hole so the rivet nuts fit properly. (Some model years may require the post to be drilled out as well to accept the 3/8 rivet nut). Use a 17/32 drill bit if this is the case.

5. Install the 3/8 rivet nut on the post and the (3) remaining 5/16 rivet nuts in the other holes using a Rivet Nut Tool. (see images above for nut locations)
6. Reinstall the tank on the rivet nuts and fasten it using the provided washers and hex head cap screws.

***NOTE:** the 4 hole bracket at the bottom of the tank will accept a GM supplied intercooler pump.

7. Using a 16 AN hose end, connect the return line on the rear facing upper fitting.
8. Connect the supply line, for the pump, to the rear facing lower tube fitting using a 1 inch hose.

APPLICATION:

2010 and up COPO Camaro with a plastic tank

Installation

1. Remove the preexisting plastic tank
2. Test fit the Moroso tank to verify that the holes in the frame rail line up with the slots on the tank. (Direct Fitment may vary based on model year)
3. If some or all of the holes **DO NOT** align properly, please refer to **Step #3** of the instructions above.
4. If the holes **DO** align properly please refer to **Step #2** of the instructions below

APPLICATION:

2010 and up COPO Camaro with an aluminum tank

Installation

1. Remove the preexisting aluminum tank
2. Install the Moroso tank on the rivet nuts, in the same location, and fasten it using the provided washers and hex head cap screws.
3. Reconnect the return and supply lines that were removed from the preexisting tank on the Moroso tank.