

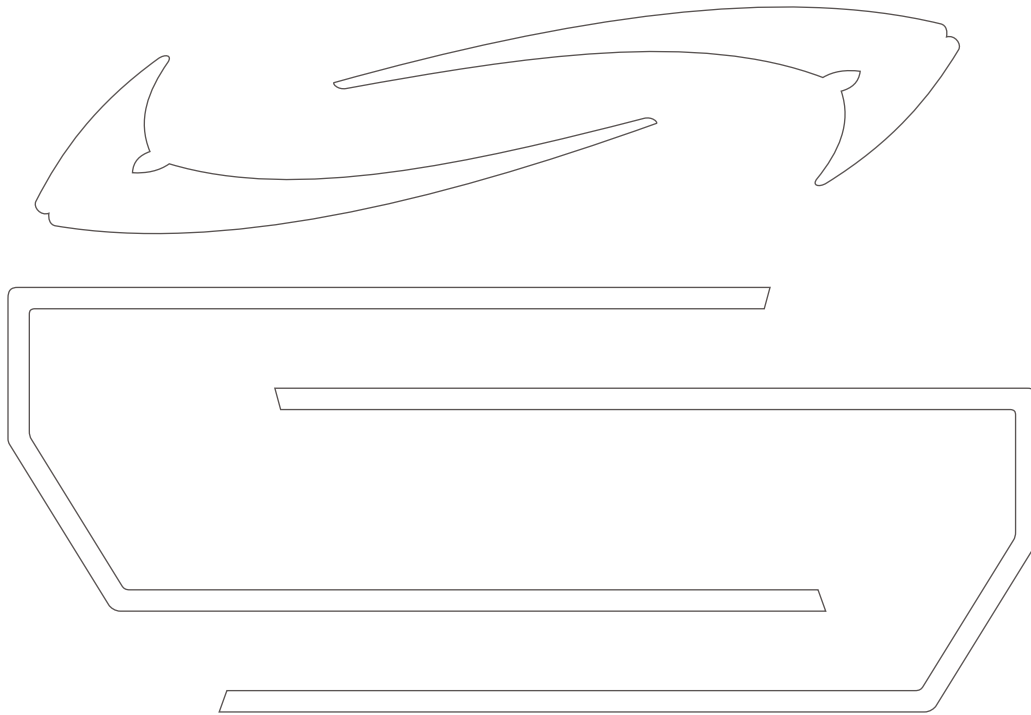

THE AUTOMOTIVE LIGHTING BENCHMARK



INSTALLATION GUIDE

XSB ACCENTS





WARNING: By reading this document, I agree it is only to be used as an educational guide. Morimoto Lighting makes no guarantee on any finished results, nor are they to be held responsible for any damage, misuse, or personal injuries. Use at your own risk. If you are unable to clearly understand and adapt the information below to your own application, professional installation is recommended.

PROFESSIONAL INSTALLATION RECOMMENDED

12V

12VDC INPUT



DO NOT CUT!



DO NOT GLUE!

SCHEMATIC

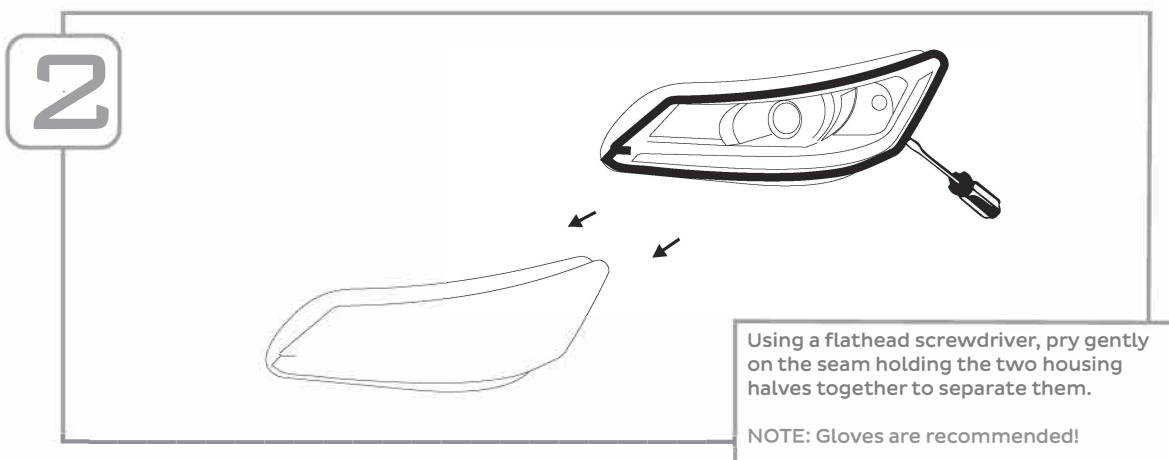
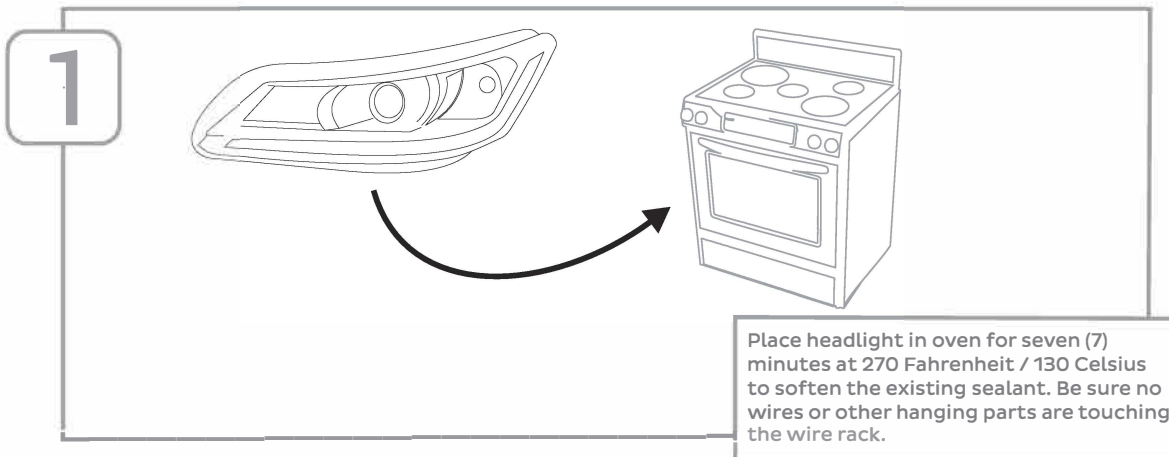

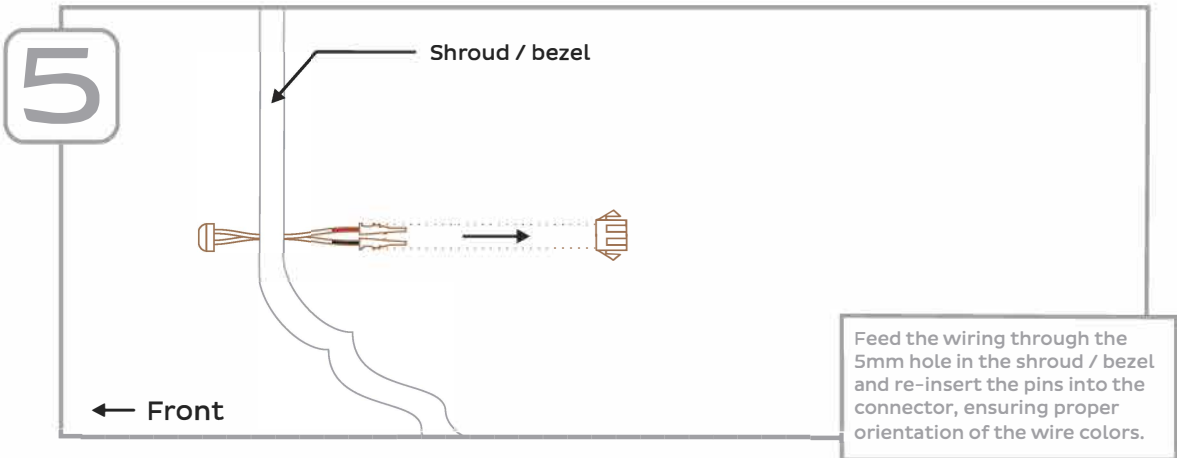
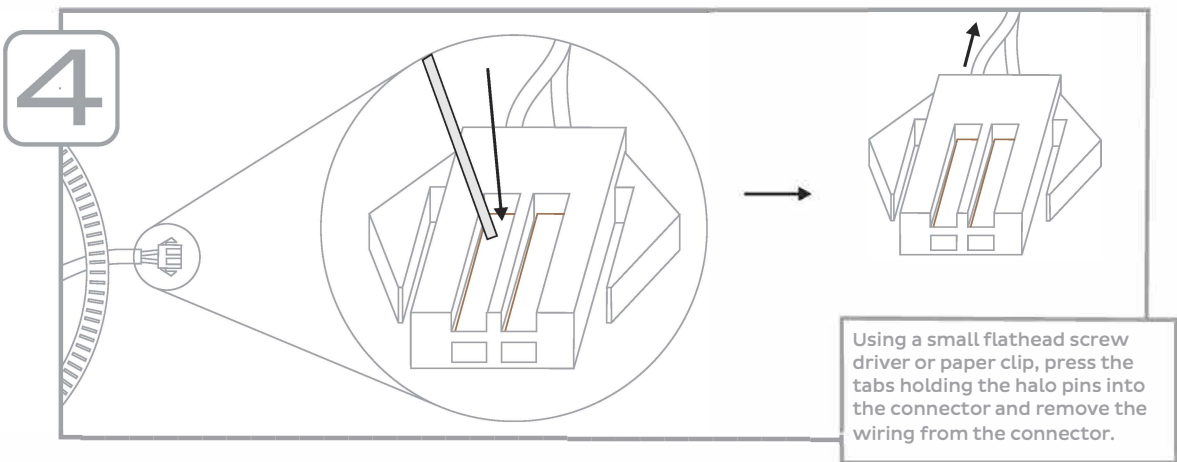
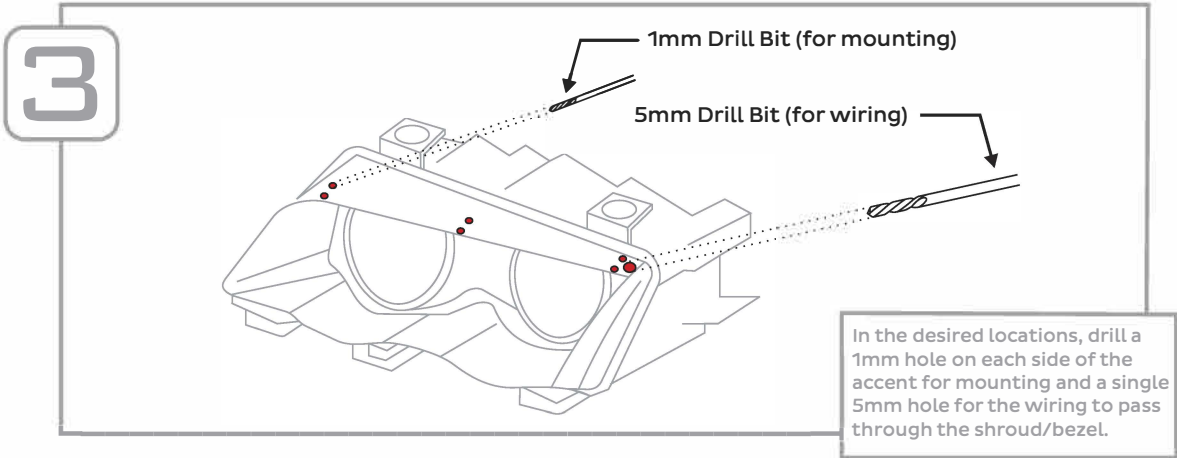

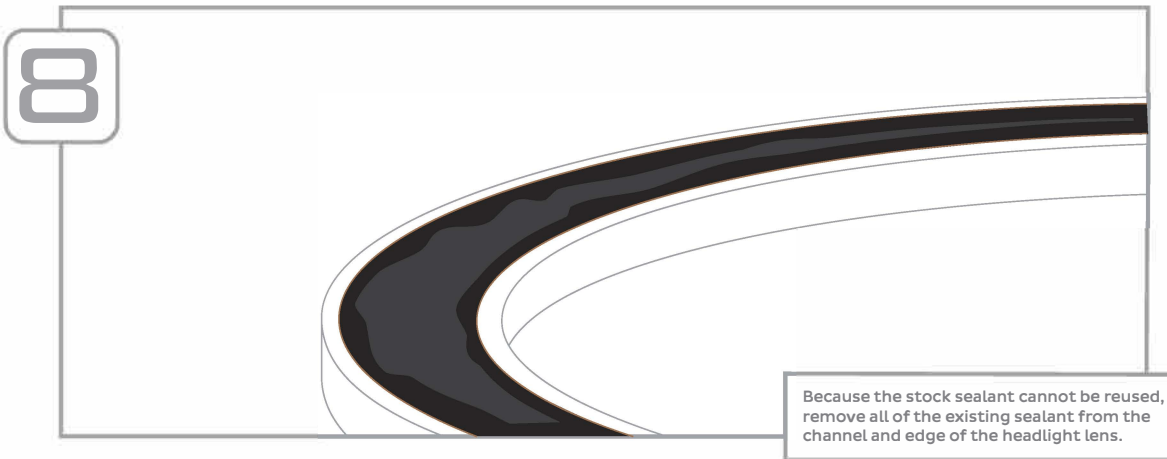
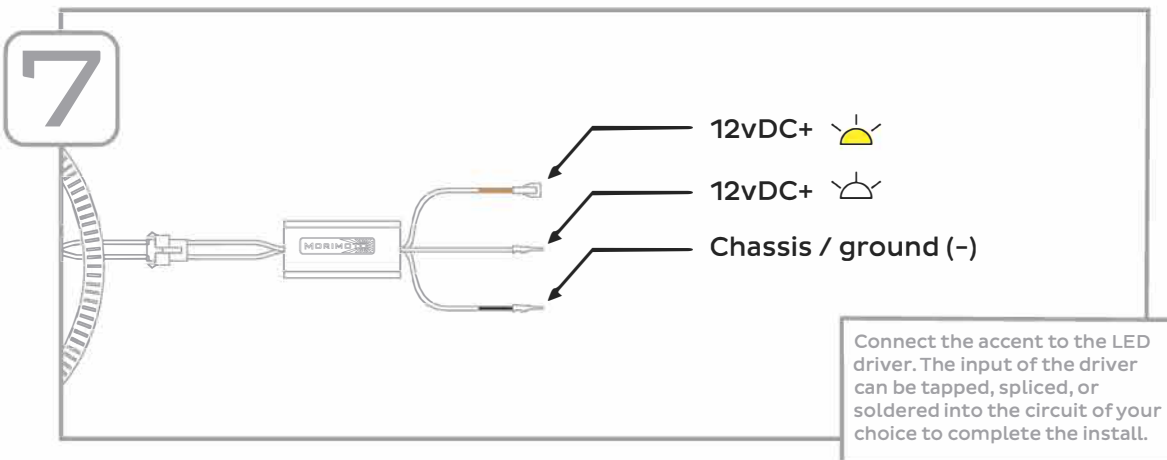
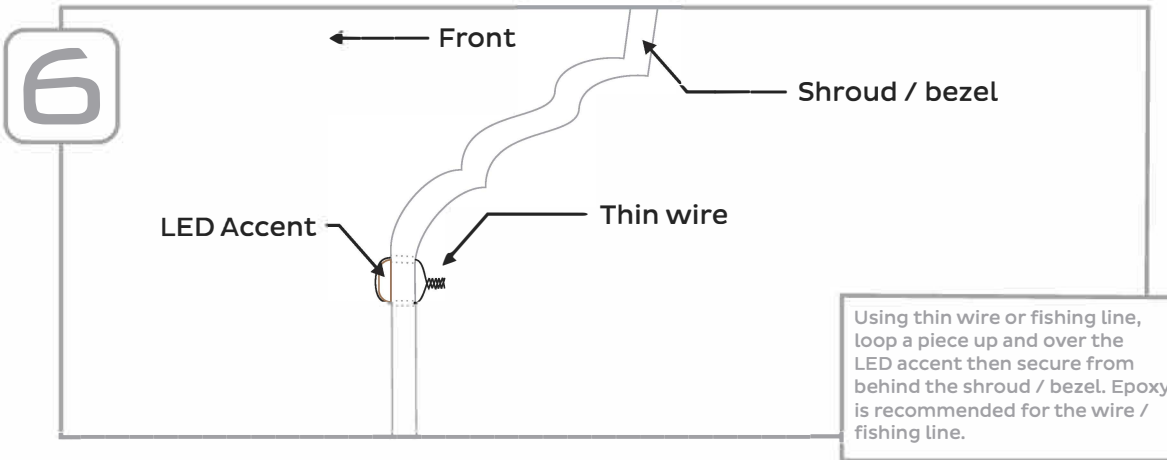

6

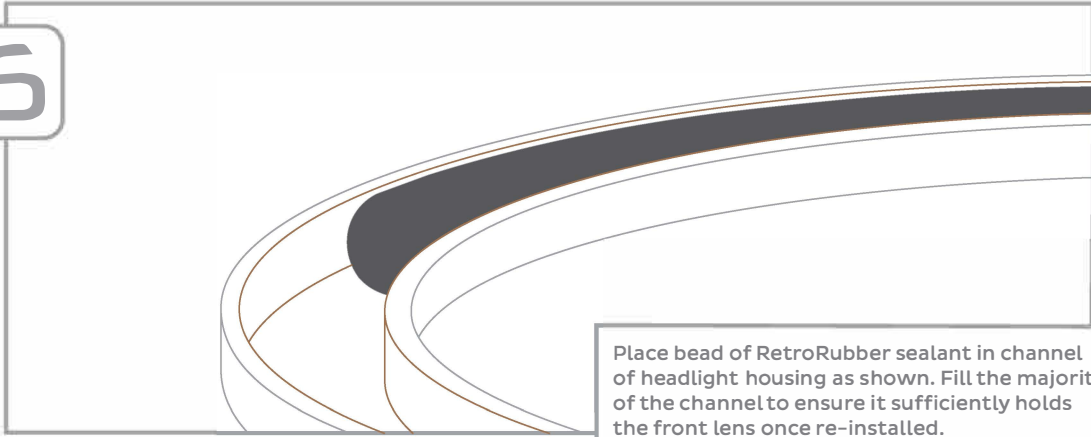

Place bead of RetroRubber sealant in channel of headlight housing as shown. Fill the majority of the channel to ensure it sufficiently holds the front lens once re-installed.

7

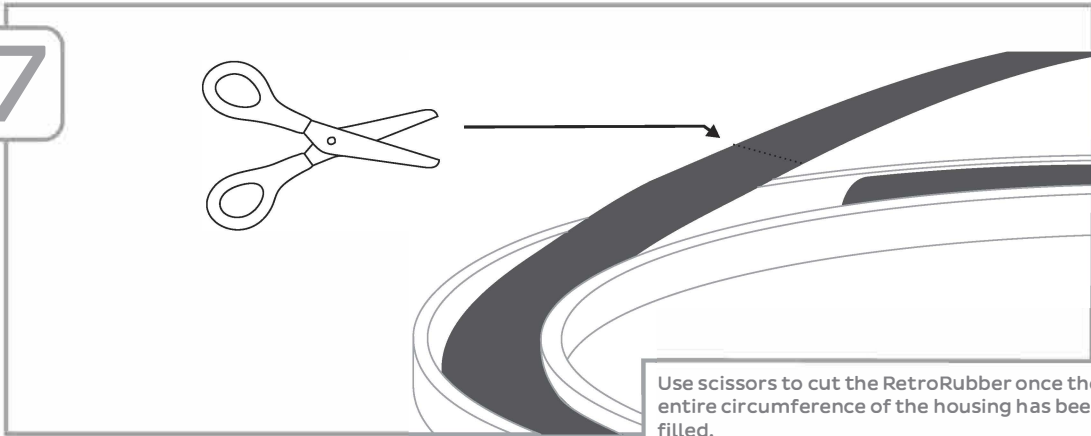

Use scissors to cut the RetroRubber once the entire circumference of the housing has been filled.

8

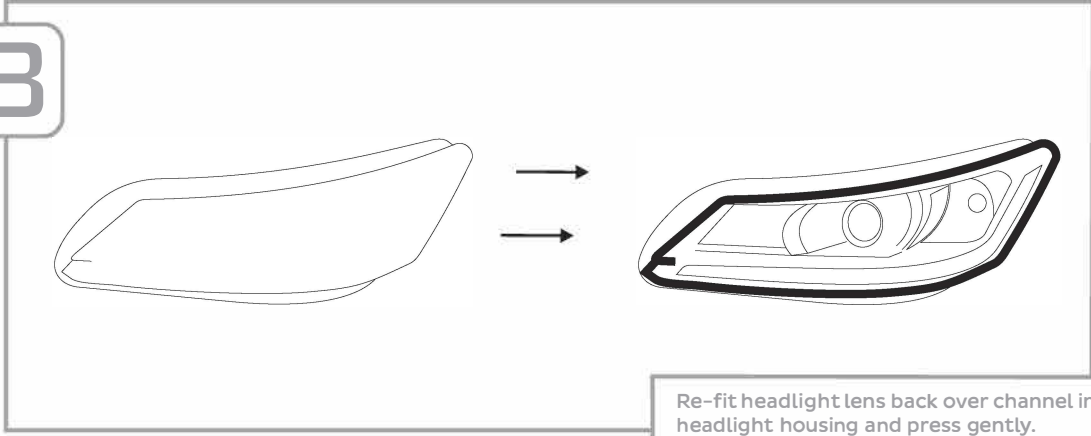

Re-fit headlight lens back over channel in headlight housing and press gently.

6

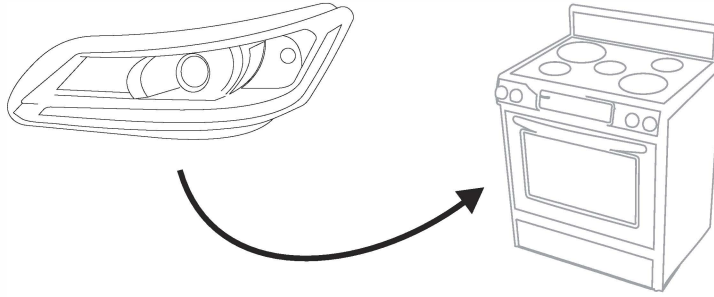

Place entire headlight in oven for seven (7) minutes at 270 Fahrenheit / 130 Celsius to soften the new sealant.

7

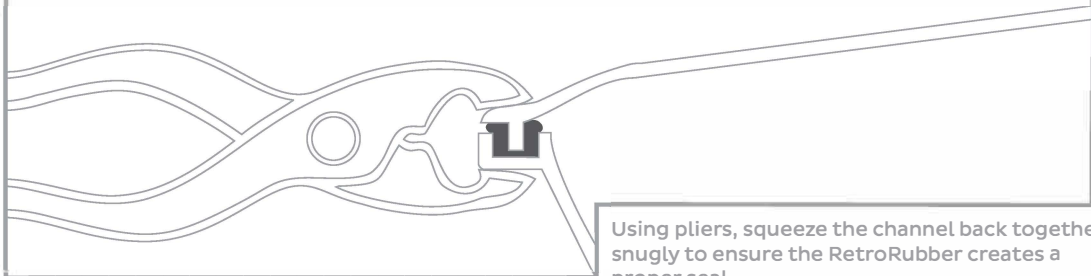

Using pliers, squeeze the channel back together snugly to ensure the RetroRubber creates a proper seal.

8

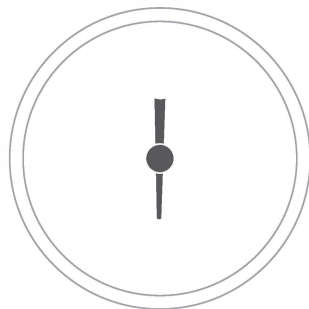

00:30:00

Allow thirty (30) minutes for headlight to sufficiently cool down prior to re-installation on car.

-END-