

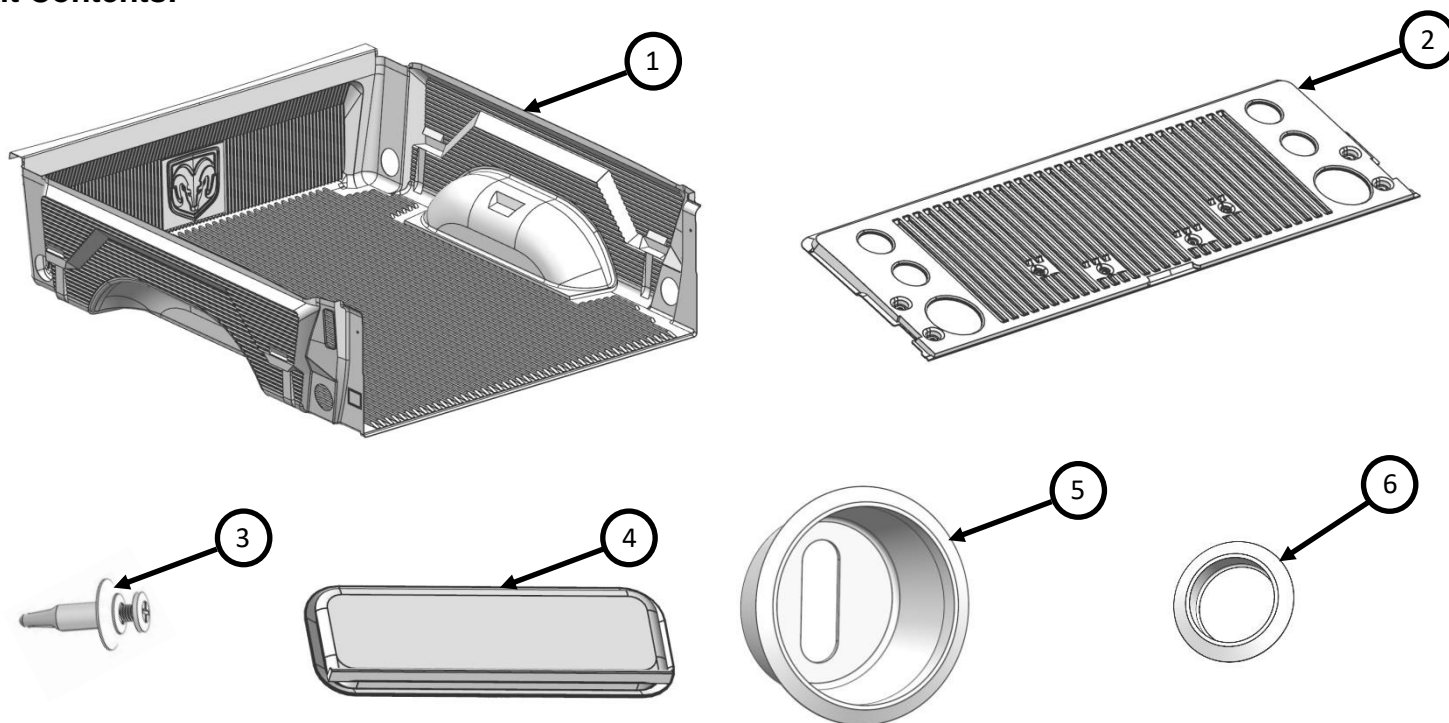

RAM UNDER RAIL BEDLINER KIT

Kit Contents:



Callout	Part Description	Quantity
1	Under Rail Bedliner	1
2	Tailgate Liner	1
3	Scrivet	2
4	Light Hole Plug	2
5	Boot Pocket	4
6	Light Switch Hole Plug	1
	Installation Instructions	1

Special Tools Required:

#30 TORX Driver, Torque Wrench

Installation Preparation:

READ ALL INSTRUCTIONS THOROUGHLY BEFORE STARTING. Improper installation may void warranty.

Clean the truck box thoroughly. Ensure floor drains (if applicable) are clear for ventilation and moisture drainage.

Tailgate Liner Installation:

Step 1 (Figure #1)

Using a TORX driver (#30), remove and save the six (6) or eight (8) tailgate panel screws (depending on tailgate style). Remove only the screws indicated by "X" in figure 1 for all tailgate configurations.

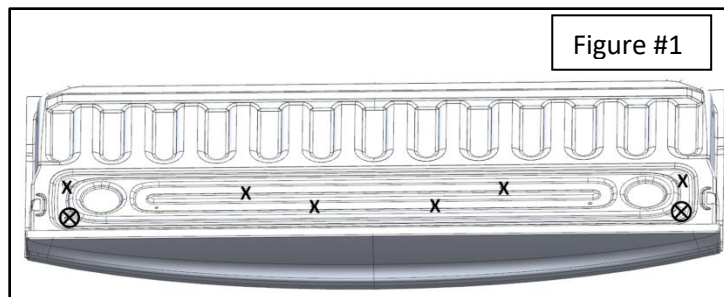

Figure #1

Step 2 (Figure #2)

Center the tailgate liner on the truck tailgate. Press the cover down and forward into place. Line up the holes in the tailgate liner with the holes in the truck tailgate.

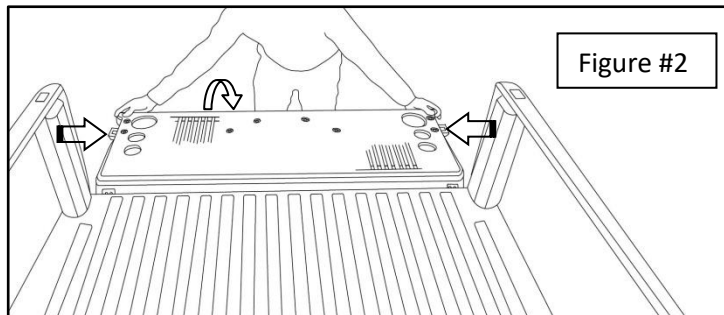

Figure #2

Step 3 (Figure #3)

Use the six (6) or eight (8) tailgate panel screws removed in **Step 1** to fasten the tailgate liner to the tailgate with a TORX driver (#30). **Do not over tighten. DO NOT USE POWER TOOLS**

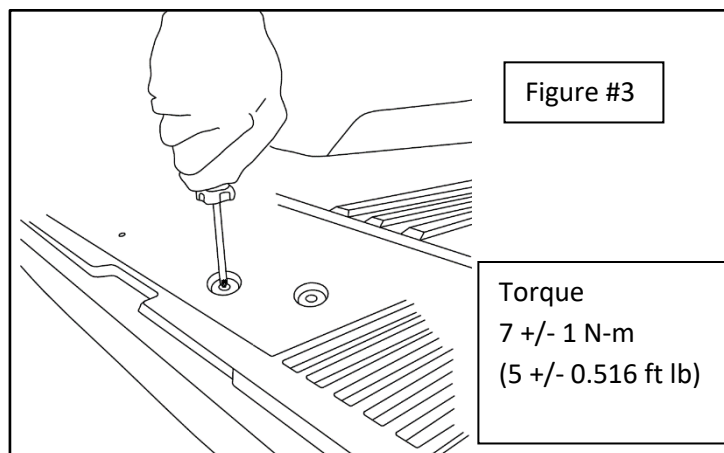

Figure #3

Torque
7 +/- 1 N-m
(5 +/- 0.516 ft lb)

Bedliner Installation:

⚠ CAUTION: It is recommended that two (2) people install the bedliner to avoid damage to the painted surfaces of the truck.

(NOTE: if the front floor tie down plugs were not removed when cleaning the bed, remove them at this time.)

NOTE 1: (Figure #4) If the Ram truck is equipped with the Mopar approved cargo management rail system, the bedliner needs to be modified as referenced in Figure #4. Local areas of the bedliner sidewall need to be removed as defined by scribe lines on the backside of the bedliner. It may be necessary to enlarge the cutouts 6mm (1/4") on all sides to allow for expansion and contraction of the bedliner during extreme temperatures.

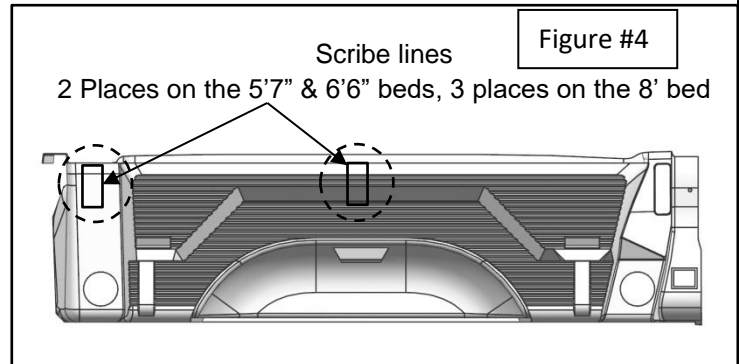

NOTE 2: (Figure #5) If the RAM truck is not equipped with cargo lamps or the cargo management rail system, the light hole plugs (callout 4) will need to be installed into the bedliner before installing the liner into the truck. The plug is installed from the outside of the bedliner. Ensure the flange that calls out "REAR" is facing the rear of the bedliner. Push the plug into the light hole cutout until plastic liner is seated between the two rubber plug flanges.

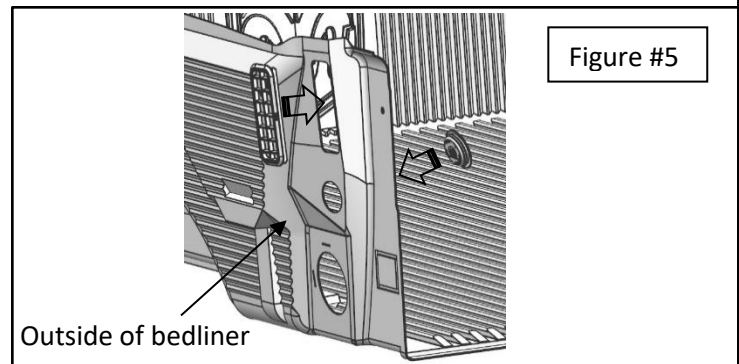

NOTE 3: (Figure #5) If the RAM truck is not equipped with a cargo lamp switch, the light switch hole plug (callout 6) will need to be installed in the bedliner. The plug can be installed before or after the bedliner is installed. Push the plug into the light switch cutout on the driver side of the liner from the inside.

NOTE 4: (Figure #6) If the RAM truck is equipped with factory equipped tie down cleats, remove them prior to the installation of the bedliner. After the bedliner installation is complete, reinstall the cleats through the oval holes provided in the bedliner.

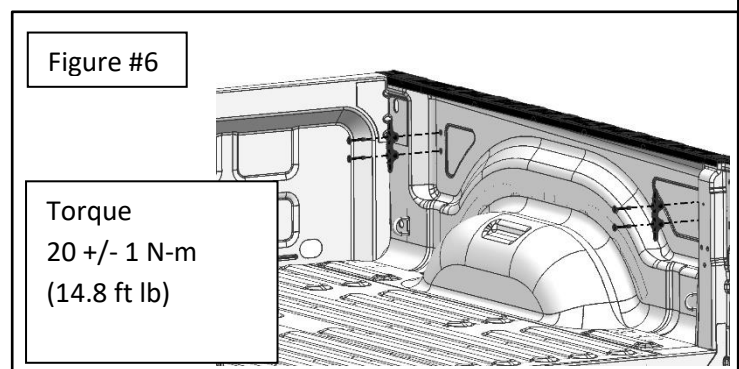

Step 4 (Figure #7)

Place the bedliner in pickup box while holding one side in the air. Slide the second side under the pickup box rail while the first comes down to rest on the floor of the pickup box. Make sure the front rail of the bedliner is over the front rail of the pickup box.

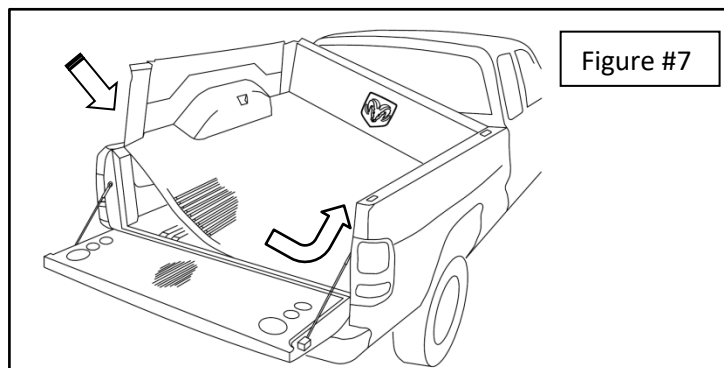

Figure #7

STEP 5 (Figure #8)

While standing at the rear of the truck lift the bedliner floor in the center. Slide the unrestrained side of the bedliner under the pickup box rail while allowing the floor to lower.

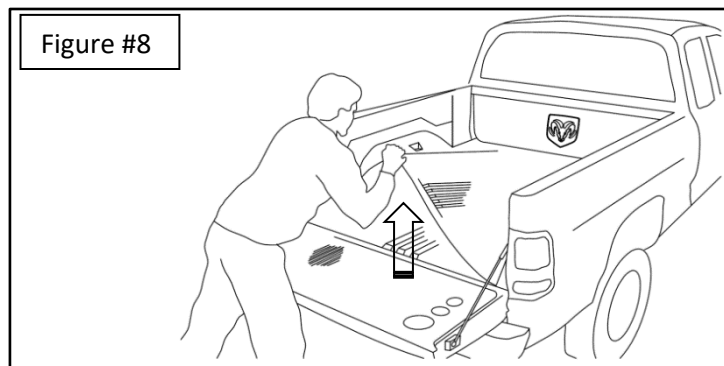

Figure #8

STEP 6

Check the overall fit. It is important that the bedliner fits securely in place under the bedrails.

STEP 7 (Figure #9)

Line up the pre drilled hole in the rear bedliner sidewall and the existing hole in the truck box rear "D" pillar sidewall. Place scrivet fastener (callout 3) through both holes. **PRESS DOWN FIRMLY** on the scrivet to seat it in place.

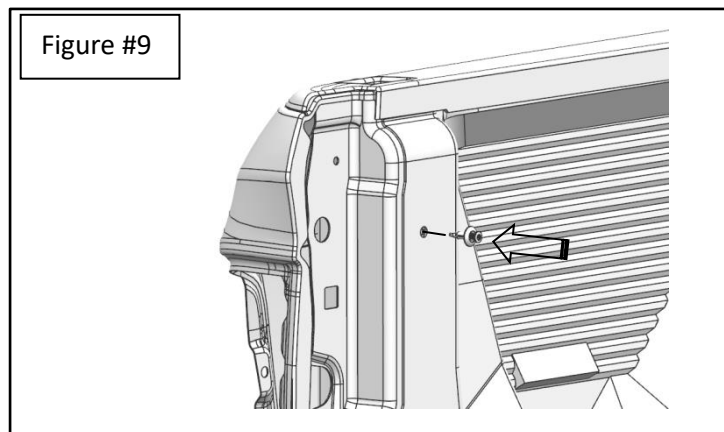
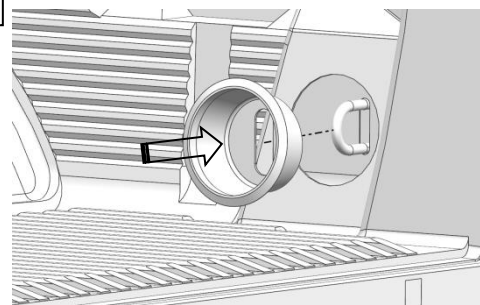

Figure #9

STEP 8 (Figure #10)

Find the end marked "DOWN" on the back side of the tie down boot pockets (callout 5). Press tie down boot pockets into the tie down holes on the bedliner with the "DOWN" writing closest to the floor. The boot pockets will snap into place.

Figure #10



ATTENTION:

Upon installation of the bedliner there may be some initial distortion which prevent the floor from lying flat. Minor to moderate distortion is a normal occurrence from the installation process and/or storage method.