

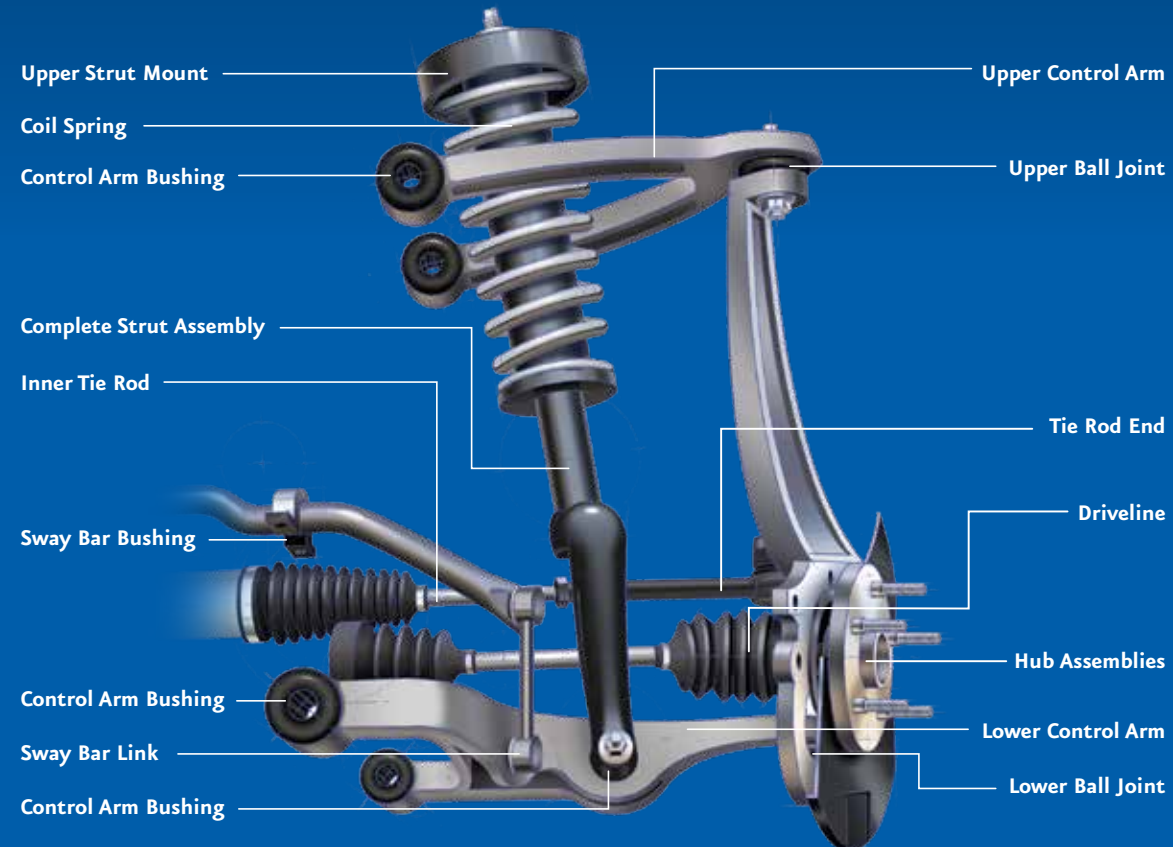

TOTAL UNDERCAR SOLUTIONS

MOOG® offers the complete steering and suspension solution today's technicians need. With MOOG you get superior products with advanced engineering and problem-solving innovation, industry-leading technical expertise, and the broadest range of foreign and domestic coverage.



INDUSTRY EXPERTISE Technical Training & Support

Today's vehicle technologies create new challenges for technicians. That's why Federal-Mogul Motorparts offers an array of industry-leading training and support options:

- Technical Education Center
- ASE-certified call center
- In-market seminars
- Live webinars
- 24/7 parts look-up
- Technical web-based library



It's superior training and support you only get with MOOG.

Problem Solvers

MOOG Problem Solver bulletins give technicians solutions to undercar repair problems. Each of these informative full-color sheets describes a specific issue, lists the vehicles affected and includes photos of failed parts. The bulletin describes and shows the MOOG component designed to solve that particular problem, and lists the necessary part numbers.



MOOG® COMPLETE STRUT ASSEMBLIES

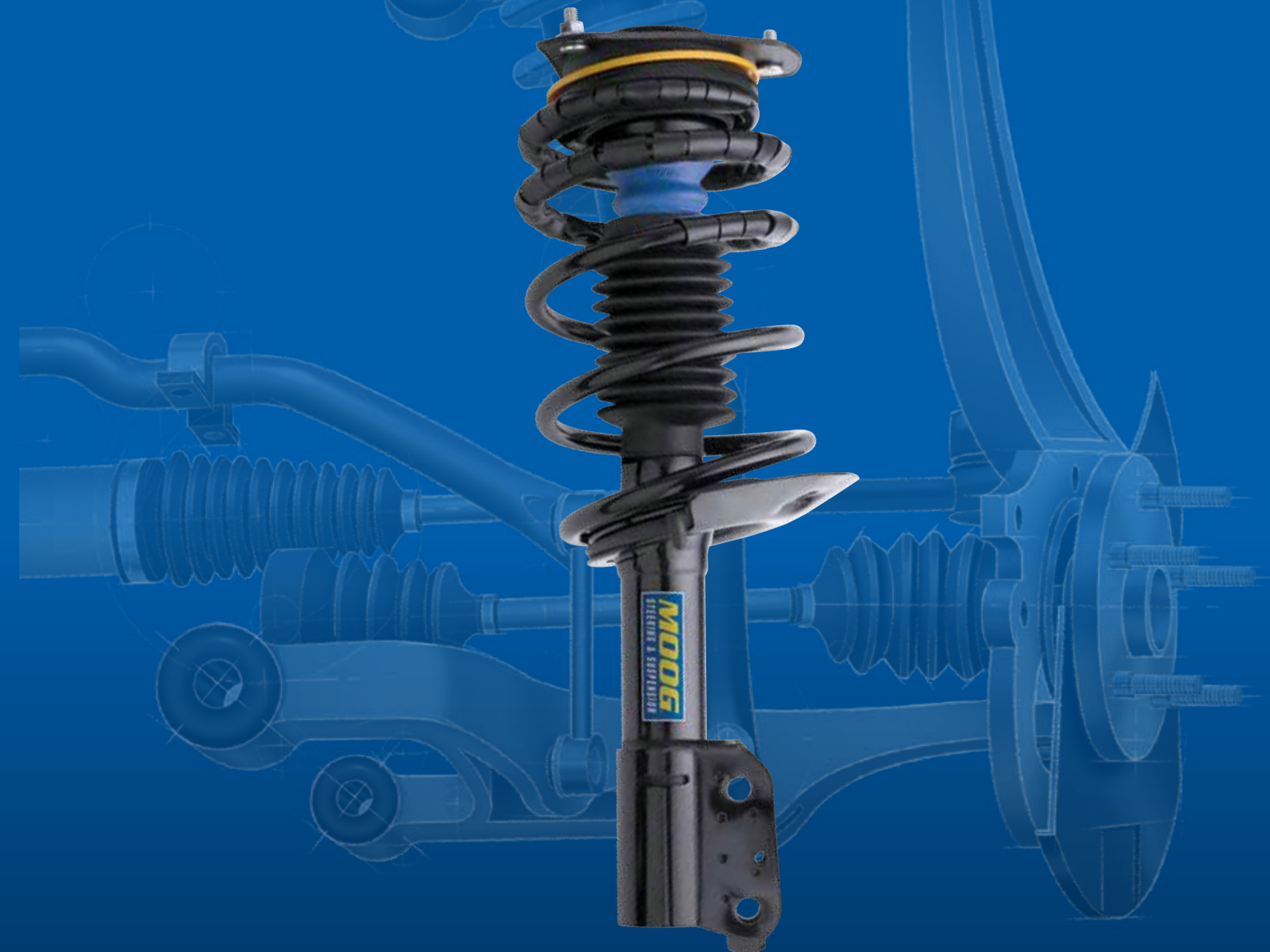

MOOG® COMPLETE STRUT ASSEMBLIES

A KEY COMPONENT OF THE COMPLETE UNDERCAR SOLUTION

When it comes to total undercar solutions, MOOG® steering and suspension components are the choice of more professional technicians. MOOG's leading-edge engineering, metallurgy and manufacturing, along with long-lasting, problem-solving performance, have earned the trust of technicians. MOOG complete strut assemblies are the latest product from this trusted brand.



MOOG COMPLETE STRUT ASSEMBLIES FEATURE SUPERIOR DESIGN AND CONSTRUCTION AND MOOG PROBLEM-SOLVING INNOVATION.

THEY ARE ENGINEERED TO:

- Improve vehicle dynamics
- Provide a smoother ride
- Last longer
- Install easily

TRIPLE PISTON ROD SEAL

OUTER WIPER SEAL cleans the piston rod, preventing contaminants from entering the strut and damaging the main seal.

MAIN SEAL with one-piece molded design features twin seal lips, optimizing sealing performance and durability.

INNER PTFE BUFFER SEAL absorbs high pressure fluid spikes caused by rough road impact, improving the efficiency of the main seal, resulting in longer seal life. Also reduces friction, for improved ride.



TRIPLE PISTON ROD SEAL

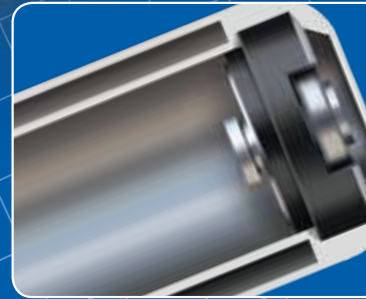

VALVING

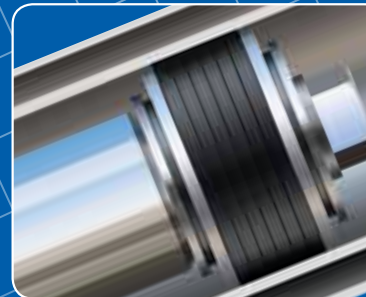

PISTON BAND

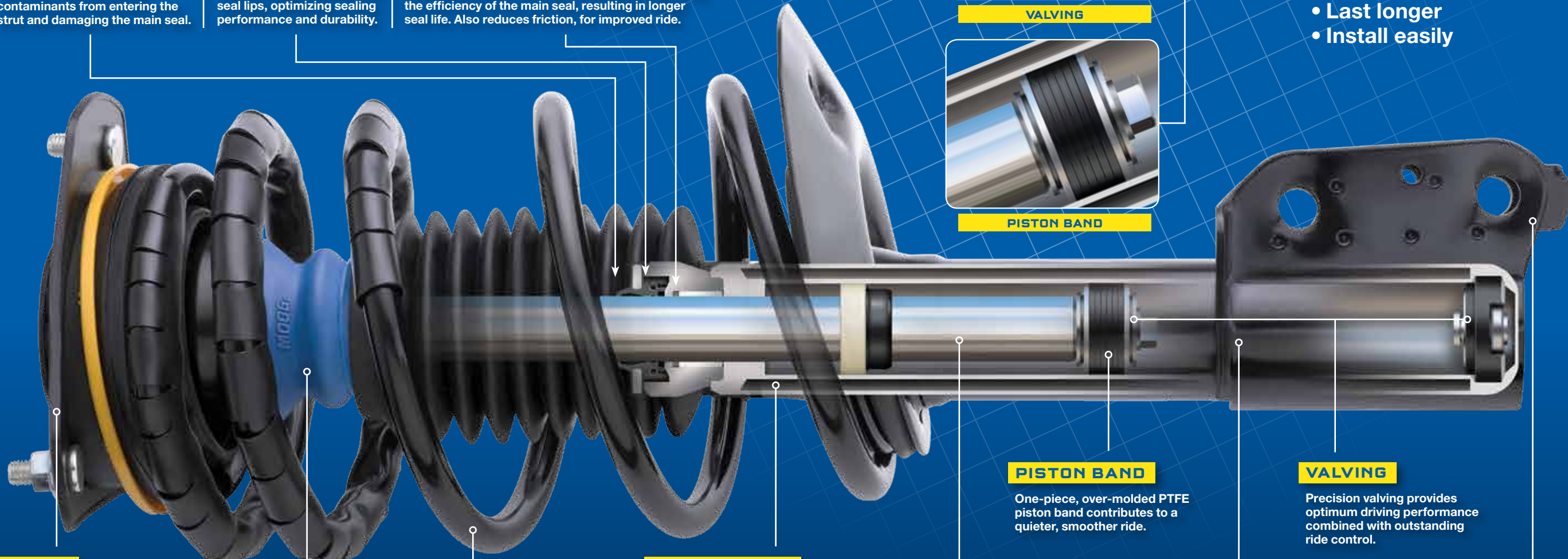

SPRING TOP PLATE

Tested to one million cycles under extreme load. Ensures smoother operation, optimal performance and an extended lifetime.

MOOG JOUNCE BUMPER

Molded from micro-cellular polyurethane. Absorbs harsh, damaging road impact and noise, for quieter driving.

SPRING

Engineered for long-term, consistent performance. Premium coating for optimal corrosion resistance.

NITROGEN GAS CHARGED

Reduces cavitation and improves valve response and efficiency, resulting in optimal control and better ride characteristics.

PISTON ROD

Highly polished, hard-chrome finish for enhanced seal function and improved durability.

PISTON BAND

One-piece, over-molded PTFE piston band contributes to a quieter, smoother ride.

VALVING

Precision valving provides optimum driving performance combined with outstanding ride control.

HYDRAULIC OIL

Low-friction, low-viscosity fluid withstands a wide range of temperatures, providing consistent performance in all conditions.

HARDWARE

OE-style installation hardware included on select applications.

ROBUST BRACKETS/ ATTACHMENT POINTS

Reinforced to further enhance component integrity and durability.