

# PROBLEM Solver™ BULLETIN

BULLETIN: 25888

## 4WD Solid Axle Ball Joints

Various Solid Axle Applications

### PROBLEM:

#### Non-Serviceable or Non-Accessible Ball Joint Grease Fitting

- Grease fitting on some serviceable ball joints cannot be accessed for service after installation due to proximity to u-joint yoke assembly.
- Parts with grease fittings located in the bottom of the ball joint can interfere with u-joint resulting in damage when service is attempted.
- Non-serviceable polymer sockets cannot flush contamination, which quickly leads to corrosion and wear.

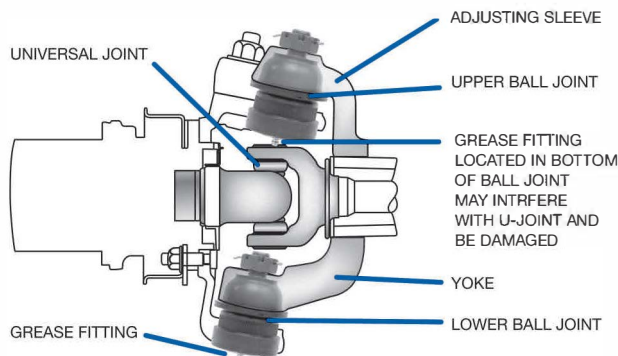

#### Make / Model / Year

Chevrolet Truck Blazer 70-91, K10 70-86, K20 70-86, V10 87-88, V1500 89-91, V20 87-88, V2500 89-91; Dodge Truck Ramcharger 74-93, W100 72-79, W150 77-93, W200 72-80, W250 81-93, W350 81-93; Ford Truck Bronco 71-79, F100 72-77, F150 76-79, F250 76-79; GMC Truck Jimmy 71-91, K1500 70-86, K2500 70-86, V1500 87-91, V2500 87-91; International Truck 100 1974, 1000D 1971, 1010 72-73, 1100 1971, 1110 72-73, 1200 1971, 1210 72-73, 1300 1971, 1310 72-73, 150 1975, 200 74-75, Scout 71-80, Terra 76-80, Traveler 76-80; Jeep Truck CJ 72-86, Cherokee 74-83, Commando 1973, Grand Wagoneer 84-91, J10 74-88, J20 74-88, Jeepster 1972, Scrambler 81-85, Wagoneer 74-83; Plymouth Truck Trail Duster 74-81

#### Replacement Part No.

K8194T

### SOLUTION:

#### MOOG® Exclusive: Improved design K8194T



- Grease fitting relocated to the side of the ball joint housing.
- Provides easy access for lubrication service.
- MOOG's hardened, powdered-metal bearing are not prone to the excessive wear plastic bearings experience under adverse conditions.

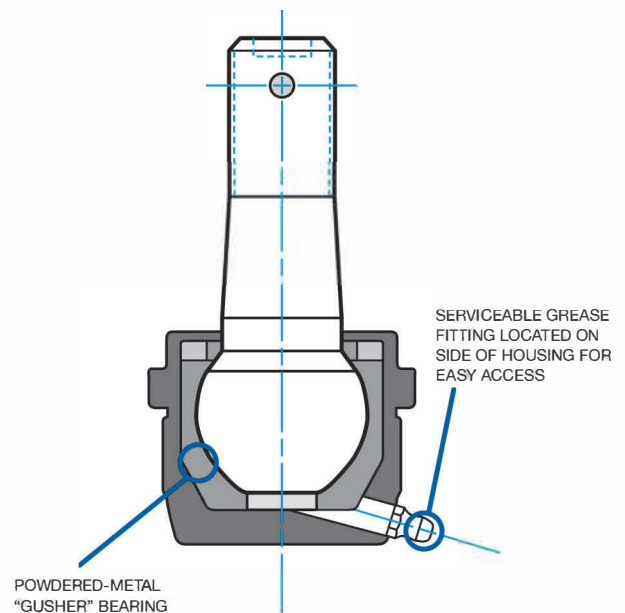

*Be Car Care Aware™*

**MOOG**  
CHASSIS PARTS™

The Problem Solver™

FEDERAL-MOGUL  
MOTORPARTS

Check out the collection of performance suspension parts we offer.