

PROBLEM SOLVER™ BULLETIN

Alignment Adjustability Restrictions

1999-2007
General Motors Trucks

PROBLEM:

Alignment adjustability restrictions

- OE adjustments may not provide adequate range to obtain a proper alignment on late model Chevrolet and GMC light trucks.
- Excessive positive or negative camber will cause the vehicle to pull left or right and will create wear on the inside or outside edge of the tire.

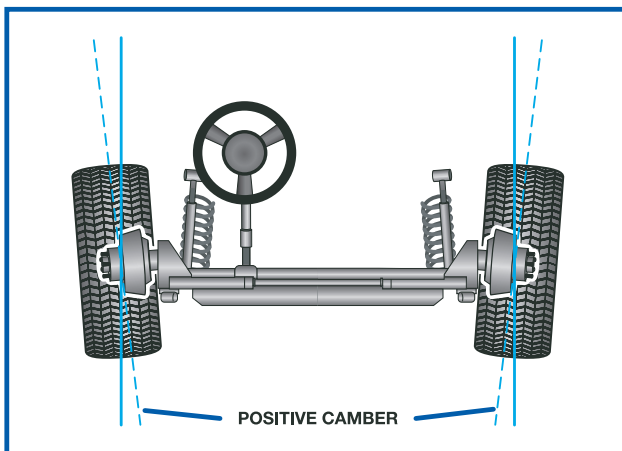

Year	Make/Model	Replacement Part Number
2002-2006	Cadillac Escalade	K6669
2002-2006	Chevrolet Avalanche	
1999-2007	Silverado 1500	
2000-2006	Suburban 1500	
2000-2006	Tahoe	
1999-2007	GMC Sierra 1500	
2000-2006	Yukon XL 1500 and Denali	K6670
2002-2006	Chevrolet Avalanche 2500HD	
2001-2007	Silverado HD 1500 & 3500	
1999-2006	Silverado 2500HD	
2000-2006	Suburban 2500HD	
2001-2007	GMC Sierra HD 1500 & 3500	
1999-2006	GMC Sierra 2500HD	
2000-2006	Yukon XL 2500HD	

SOLUTION:

MOOG® upper control arm offset bushings for camber and caster



- Provides an effective, low-cost means of obtaining more camber (and/or caster).
- Offers an additional 2 degrees of camber change.
- Used with factory cam adjuster, but allows greater range.
- Designed with OE-type material to maintain ride quality and service life.
- Fast and simple installation – made easier with the use of T40259, a bushing adapter specially designed to work with K6669 and K6670.

REPLACEMENT BUSHINGS

