



THE PROBLEM SOLVER®

FRONT LOWER BALL JOINT
2007-2012 NISSAN SENTRA

PROBLEM:

Replacement ball joint not available

OE dealers do not offer a replacement front lower ball joint by itself. So to replace the lower ball joint, installers must purchase the entire control arm.



REPLACEABLE PART.
REPLACE WITH MOOG® PROBLEM SOLVER® K500223 LOWER BALL JOINT.

USING A BALL JOINT PRESS TOOL

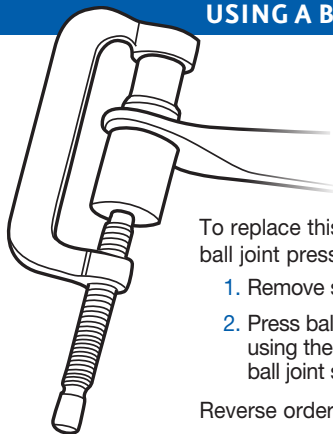

To replace this ball joint, use a suitable ball joint press tool.

1. Remove snap ring.
2. Press ball joint out using the appropriate ball joint service kit.

Reverse order to install the new ball joint.

Description	Years	Make/Model	P/N
Lower Ball Joint	2007-2012	Nissan Sentra	K500223

SOLUTION:

MOOG® Problem Solver® K500223 Lower Ball Joint

MOOG® Problem Solver® ball joint K500223 is the perfect replacement for the failed control arm ball joint. The knurled housing enables it to fit securely into the control arm. The K500223 design, which incorporates an all-metal gusher bearing and full-ball stud, is both smooth and durable.

- All-metal “gusher” bearing design provides strength and allows lubricant to penetrate bearing surfaces for longer life.
- Greaseable design flushes contamination and keeps part lubricated.
- MOOG patented domed cover plate and Belleville washer ensure proper preload and consistent socket torque for the life of the part.
- Metal stud with full-ball configuration provides smooth, even rotational movement.
- MOOG “grease relief” polychloroprene boot lasts longer and directs contaminants out of the socket and away from brake components during lubrication.



K500223



Check out the collection of performance suspension parts we offer.