



## FRONT UPPER BALL JOINT

1989-1997 MAZDA MX-5 MIATA

# THE PROBLEM SOLVER®

### PROBLEM:

#### Replacement ball joint not available

OE dealers do not offer a replacement front upper ball joint by itself. So to replace the upper ball joint, installers must purchase the entire control arm.

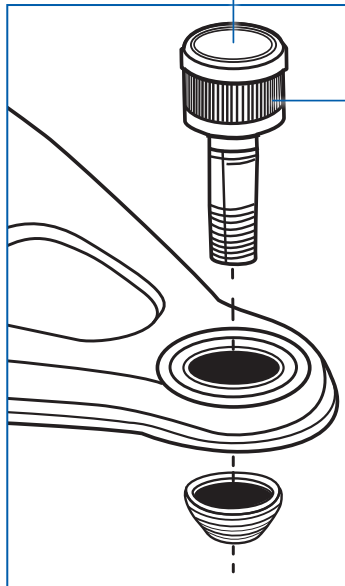
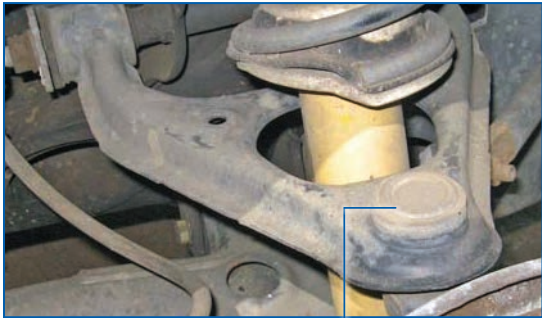

REPLACEABLE PART. REPLACE WITH MOOG® PROBLEM SOLVER® K500210 UPPER BALL JOINT.

Description	Years	Make/Model	P/N
Upper Ball Joint	1989-1997	Mazda Miata	K500210

### SOLUTION:

#### MOOG® Problem Solver® K500210 Upper Ball Joint

MOOG® Problem Solver® ball joint K500210 is the perfect replacement for the failed control arm ball joint. Its knurled housing enables it to fit securely into the control arm. Its design, which incorporates an all-metal gusher bearing and full ball stud, is both smooth and durable.

- All-metal “gusher” bearing design provides strength and allows lubricant to penetrate bearing surfaces for longer life.
- Greaseable design flushes contamination and keeps part lubricated.
- MOOG patented domed cover plate and Belleville washer ensure proper preload and consistent socket torque for the life of the part.
- Metal stud with full-ball configuration provides smooth, even rotational movement.
- MOOG “grease relief” polychloroprene boot lasts longer and directs contaminants out of the socket and away from brake components during lubrication.

