

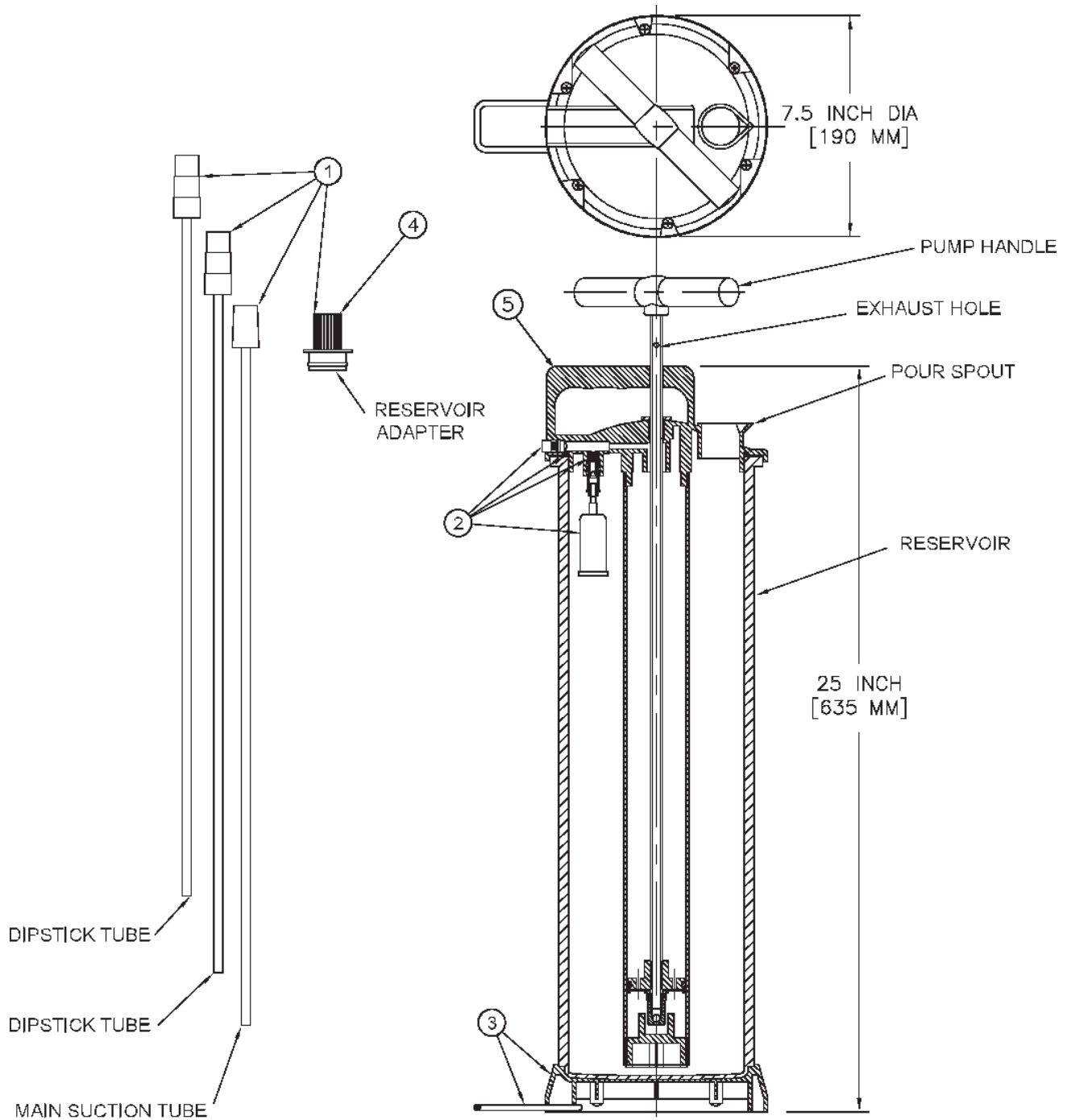

**Fluid Evacuator
1.9 Gallon/7.3 Liter Capacity**

MODEL MV7400





Model MV7400 Service Items					
Item	Description	Part No.	Item	Description	Part No.
1	Vacuum tube Kit	822599	3	Base Kit *	822606
2	Float and Valve Kit	822604	4	Plastic Adapter	822597
* Consists of base and foot bracket			5	Evacuator Top with Gasket	822832

©Precaution:

This equipment is designed for servicing a variety of vehicles in a safe and convenient manner. However, differences in engine blocks and dip stick configurations may make it impossible to use this equipment on every vehicle. The procedures documented in this manual are to serve as guidelines for general use of this equipment. In addition to these guidelines, always follow the manufacturer's recommended procedures when attempting to use this equipment on each unique vehicle. Do not attempt to force the tubes included with this equipment into a dip stick tube that will not readily accept the smaller of the two tubes. The tubes would appear to be too large and not designed to be used with the particular vehicle.

Draining oil with this evacuator unit through the dipstick tube is expected to be simple and straightforward. The instructions were written as a general guideline only.

NOTE: DO NOT FORCE THE TUBE INTO ANY CRANKCASE AND MAKE SURE THAT YOU STOP PUSHING THE TUBE IN IF ANY FORCE IS RECOGNIZED. YOUR PARTICULAR DEALER SHOULD BE CONTACTED FOR DETAIL ON USING THIS EQUIPMENT TO EVACUATE OIL FROM YOUR CAR IF ISSUES ARISE.

Always read carefully and understand instructions prior to using this equipment.

Tighten lid-to-reservoir screws before first use and periodically to ensure proper seal.

Recommended for use with the following fluids:

- Engine oil
- Gear oil
- Transmission oil
- Power steering fluid
- Brake fluid
- Coolants



Automatic shut-off function

The model MV7400 Fluid Evacuator is equipped with an automatic shut-off valve that prevents overfilling the fluid reservoir. As the evacuated fluid nears the top of the reservoir it will raise a float, interrupting the flow of the fluid being extracted.

Extracting motor oil through the dipstick tube

1. Operate the vehicle to warm the engine oil to a normal operating temperature.
Caution: Do not attempt to extract fluids at temperatures greater than 175° Fahrenheit (80° Celsius).
2. Properly park the vehicle on level ground and turn the engine off.
3. Remove the engine oil dipstick.
4. Select and insert the appropriate diameter dipstick tube into the dipstick fill hole until it reaches the bottom of the crankcase.
5. Connect the main suction tube to the dipstick tube.
6. Insert the rubber plug of the main suction tube into the reservoir adapter, and then insert the adapter into the pour spout on the top of the reservoir. Ensure the tube connections are tight to prevent leakage.
7. Extract the used engine oil by pumping the evacuator handle several times to create a vacuum. Once the oil begins to flow into the reservoir, continue to operate the pump until all oil has been drained from the crankcase, or the reservoir is full. **Note:** Due to varying engine fluid capacities, if the crankcase capacity exceeds 7.7 Quarts/7.3 liters, it may be necessary to empty the fluid reservoir before resuming the extraction process.
8. Remove the reservoir adapter from the reservoir, pour the used engine oil from the reservoir into a suitable container, then dispose of the oil in an appropriate manner.
9. Rinse the evacuator reservoir, pump, adapter, and tubes with clean solvent or engine degreaser, and allow them to dry thoroughly.
10. Refill the engine with new oil in accordance with a proper vehicle maintenance guide.

© Indicates Change

Extracting transmission fluid through the dipstick tube

1. Operate the vehicle to warm the transmission fluid to a normal operating temperature.
Caution: Do not attempt to extract fluids at temperatures greater than 175° Fahrenheit (80° Celsius).
2. Properly park the vehicle on level ground and turn the engine off.
3. Remove the transmission fluid dipstick.
4. Insert the appropriate diameter dipstick tube into the dipstick fill hole until it reaches the bottom of the transmission pan.
5. Connect the main suction tube to the dipstick tube.
6. Insert the rubber plug of the main suction tube into the reservoir adapter, and then insert the adapter into the pour spout on the top of the reservoir. Ensure the tube connections are tight to prevent leakage.
7. Extract the used transmission fluid by pumping the evacuator handle several times to create a vacuum. Once the fluid begins to flow into the reservoir, continue to operate the pump until all the fluid has been drained from the transmission pan.
8. Remove the reservoir adapter from the reservoir, pour the used transmission fluid from the reservoir into a suitable container, then dispose of the fluid in an appropriate manner.
9. Rinse the evacuator reservoir, pump, adapter, and tubes with clean solvent or engine degreaser, and allow them to dry thoroughly.
10. Refill the transmission with new fluid in accordance with a proper vehicle maintenance guide.

WARNING

In some applications, this may require jacking or lifting the vehicle. Use appropriate safety stands to avoid serious or fatal injury.

Extracting oil from a differential

1. Operate the vehicle to warm the differential to a normal operating temperature. **Caution:** Do not attempt to extract fluids at temperatures greater than 175° Fahrenheit (80° Celsius).
2. Properly park the vehicle on level ground and turn the engine off. If required, properly lift and support the vehicle to allow access to the differential fill plug located on the differential housing or cover.
3. Remove the differential fill plug.
4. Insert the appropriate diameter dipstick tube into the fill hole until it reaches the bottom of the differential housing.
5. Connect the main suction tube to the dipstick tube.
6. Insert the rubber plug of the main suction tube into the reservoir adapter, and then insert the adapter into the pour spout on the top of the reservoir. Ensure the tube connections are tight to prevent leakage.
7. Extract the used oil from the differential by pumping the evacuator handle several times to create a vacuum. Once the fluid begins to flow into the reservoir, continue to operate the pump until all the fluid has been drained from the differential.
8. Remove the reservoir adapter from the reservoir, pour the used differential oil from the reservoir into a suitable container, then dispose of the oil in an appropriate manner.
9. Rinse the evacuator reservoir, pump, adapter, and tubes with clean solvent or engine degreaser, and allow them to dry thoroughly.
10. Refill the differential with new oil in accordance with a proper vehicle maintenance guide.

WARNING

Never remove the cap from the radiator or expansion tank while the engine is at operating temperature. Always allow the engine to cool before removing the radiator cap or expansion tank cap. The cooling system is under pressure. Failure to allow the engine to cool before attempting to remove the cap could result in serious injuries.

Extracting coolant from a radiator or expansion tank

1. Properly park the vehicle on level ground and turn the engine off.
2. Allow engine to cool completely. **Caution:** Do not attempt to extract fluids at temperatures greater than 175° Fahrenheit (80° Celsius).
3. Remove the radiator or expansion tank cap.

4. Insert the main suction tube into the radiator or expansion tank until it reaches the bottom.
5. Insert the rubber plug of the main suction tube into the reservoir adapter, and then insert the adapter into the pour spout on the top of the reservoir. Ensure the tube connections are tight to prevent leakage.
6. Extract the used coolant by pumping the evacuator handle several times to create a vacuum. Once the coolant begins to flow into the reservoir, continue to operate the pump until all the coolant has been drained from the radiator or expansion tank. **Note:** *Due to varying engine fluid capacities, if the coolant system capacity exceeds 7.7 Quarts/7.3 liters, it may be necessary to empty the fluid reservoir before resuming the extraction process.*
7. Remove the reservoir adapter from the reservoir, pour the used coolant from the reservoir into a suitable container, then dispose of the coolant in an appropriate manner.
8. Rinse the evacuator reservoir, pump, adapter, and tubes with clean solvent or engine degreaser, and allow them to dry thoroughly.
9. Refill the radiator or coolant reservoir with new coolant in accordance with a proper vehicle maintenance guide.

Extracting brake fluid from the master cylinder

1. Properly park the vehicle on level ground and turn the engine off.
2. Clean the exterior of the master cylinder and master cylinder cap to prevent dirt from entering the master cylinder when the cap is removed.
3. Remove the cap from the master cylinder reservoir.

WARNING

Prior to inserting the extraction tube into the master cylinder reservoir, be sure that the extraction tube is clean and free of any other types of fluid. Failure to do so could result in contamination of the brake fluid in the hydraulic system and cause potential brake failure.

4. Insert the rubber plug of the main suction tube into the reservoir adapter, and then insert the adapter into the pour spout on the top of the reservoir. Ensure the tube connections are tight to prevent leakage.
5. Insert the main suction tube into the master cylinder.
6. Extract the used brake fluid by pumping the evacuator handle several times to create a vacuum. Once the fluid begins to flow into the reservoir, continue to operate the pump until all the fluid has been drained from the master cylinder.
7. Remove the reservoir adapter from the reservoir, pour the used brake fluid from the reservoir into a suitable container, then dispose of the fluid in an appropriate manner.
8. Rinse the evacuator reservoir, pump, adapter, and tubes with clean solvent or engine degreaser, and allow them to dry thoroughly.
9. After all repairs are completed, refill the brake system in accordance with a proper vehicle maintenance guide.

Extracting power steering fluid from the power steering fluid reservoir

1. Properly park the vehicle on level ground and turn the engine off.
2. Clean the exterior of the power steering fluid reservoir to prevent dirt from entering the reservoir when the cap is removed.
3. Remove the cap from the power steering fluid reservoir.
4. Insert the rubber plug of the main suction tube into the reservoir adapter, and then insert the adapter into the pour spout on the top of the reservoir. Ensure the tube connections are tight to prevent leakage.
5. Insert the main suction tube into the power steering fluid reservoir.
6. Extract the used power steering fluid by pumping the evacuator handle several times to create a vacuum. Once the fluid begins to flow into the reservoir, continue to operate the pump until all the fluid has been drained from the power steering fluid reservoir.
7. Remove the reservoir adapter from the evacuator reservoir, pour the used power steering fluid from the reservoir into a suitable container, then dispose of the fluid in an appropriate manner.
8. Rinse the evacuator reservoir, pump, adapter, and tubes with clean solvent or engine degreaser, and allow them to dry thoroughly.
9. Refill the power steering system with new fluid in accordance with a proper vehicle maintenance guide.