



INSTALLATION GUIDE

**PERFORMANCE TURBO INLET PIPE, FITS VOLKSWAGEN &
AUDI MQB PLATFORM (1.8T/2.0T) 2015+ | SKU: MMAI-MK7-TI**



TABLE OF CONTENTS

Pg 01 RESOURCES & CONTACT INFORMATION

Pg 02 EXPLODED DIAGRAM

Pg 03 PARTS BREAKDOWN

IMPORTANT SAFETY INFORMATION

TOOLS NEEDED

INSTALLATION TIME

INSTALLATION DIFFICULTY

INSTALLATION INSTRUCTIONS

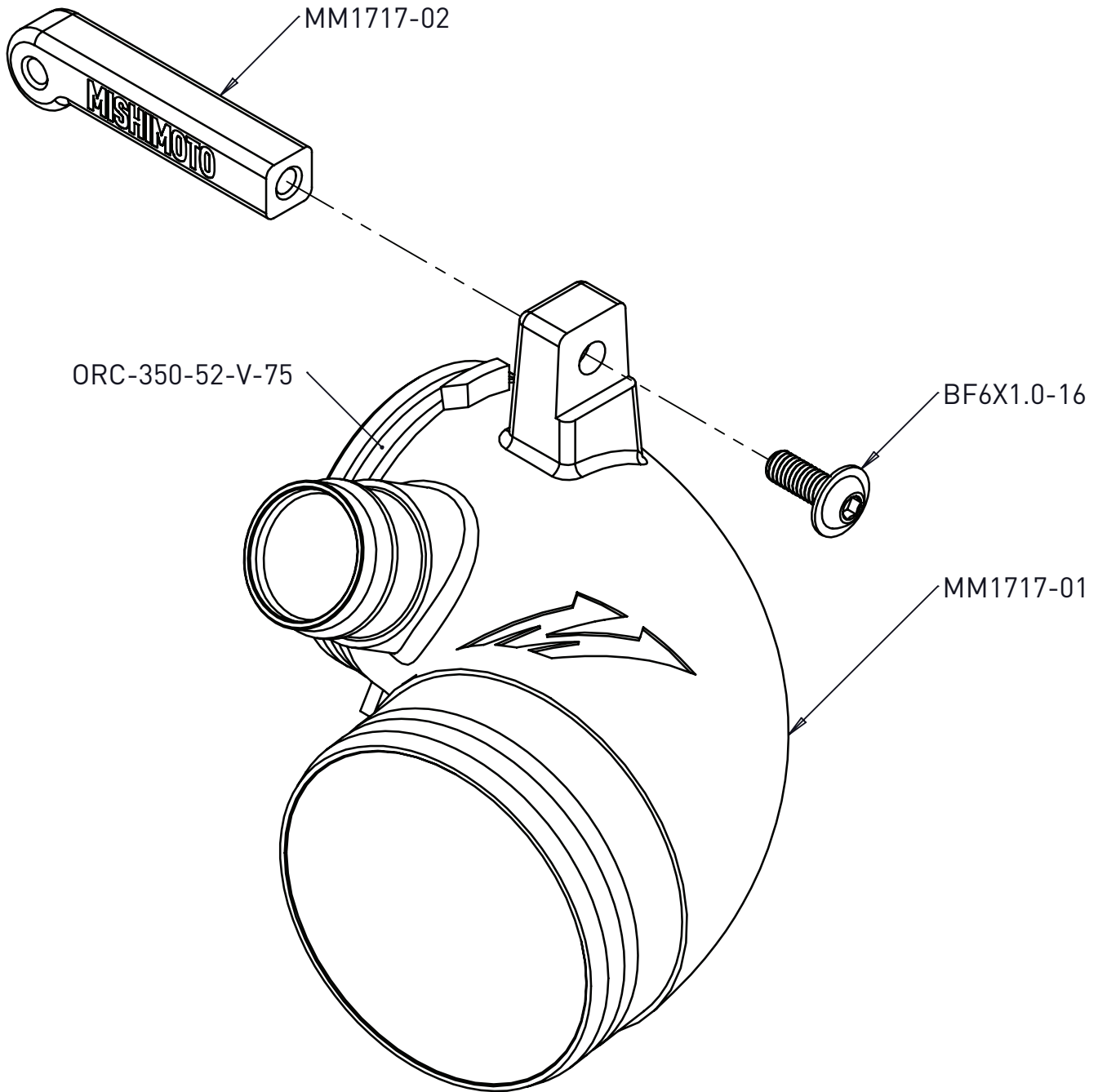

PARTS BREAKDOWN

PART NUMBER	DESCRIPTION	QTY
MM1717-01	PIPE	1
MM1717-02	BRACKET	1
BF6X1.0-16	BOLT	2
ORC-350-52-V-75	O-RING	1

IMPORTANT SAFETY INFORMATION

- › Mishimoto recommends you use safety glasses and protective gloves during the install of their products
- › Raise vehicle only on jack stands or on a vehicle lift
- › Allow vehicle to cool completely prior to attempting installation
- › Do not run the engine or drive the vehicle while overheating; serious damage can occur
- › Please dispose of any liquids properly
- › Mishimoto is not responsible for any vehicle damage or personal injury due to installation errors, misuse, or removal of Mishimoto products

INSTALLATION TIME 30 MINUTES

INSTALLATION DIFFICULTY 

TOOLS NEEDED

- | | |
|------------|------------------|
| 7MM SOCKET | 4MM ALLEN WRENCH |
| ¼" RATCHET | PICK TOOL |
| T-30 TORX | PLIERS |

INSTALLATION INSTRUCTIONS

1. Remove the worm gear clamp and spring clamp securing the air intake tube to the stock turbo inlet pipe and air box. (1x worm gear clamp, 1x spring clamp)



2. Remove the PCV breather hose quick-disconnect fitting from the stock turbo inlet pipe using a pick tool. (1x quick-disconnect fitting)



CONTINUED ON FOLLOWING PAGE

3. Loosen the T-30 Torx bolt securing the stock turbo inlet pipe. This bolt is a captive fastener and should not be removed from the turbocharger. (1x T-30 Torx bolt)



4. Rotate the stock turbo inlet pipe clockwise (towards the firewall) and then pull it away from the turbocharger to remove.

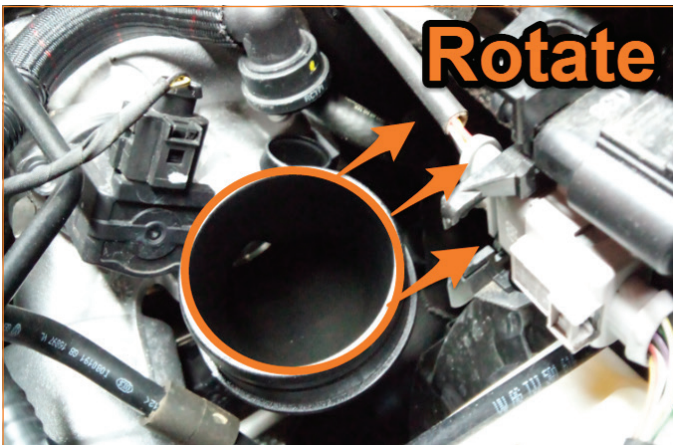

5. Fasten the MM1717-02 bracket to the MM1717-01 pipe using the provided Allen bolt. Leave the bolt loose. (1x BF6X1.0-16 bolt)



6. Align the Mishimoto turbo inlet pipe with the turbocharger inlet, then push inward and rotate counterclockwise. Tighten the T-30 Torx bolt first, then tighten the Allen bolt.



7. Connect the PCV breather hose to the Mishimoto turbo inlet pipe.



8. Reinstall the air intake tube. (1x worm gear clamp, 1x spring clamp)



Congratulations! You have finished your installation.