

WIRING INSTRUCTIONS

TITLE

LARGE DRILL POWER UNIT

BULLETIN
58-01-0371

DATE
Mar. '75

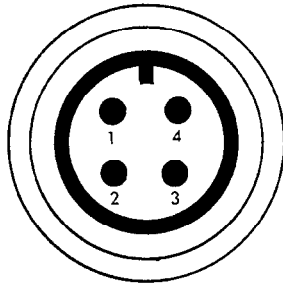

120V
CORD PLUG FACE

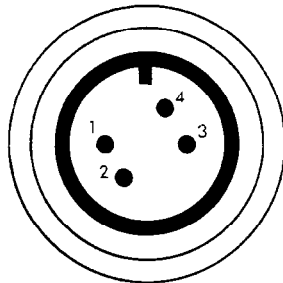

240V
CORD PLUG FACE

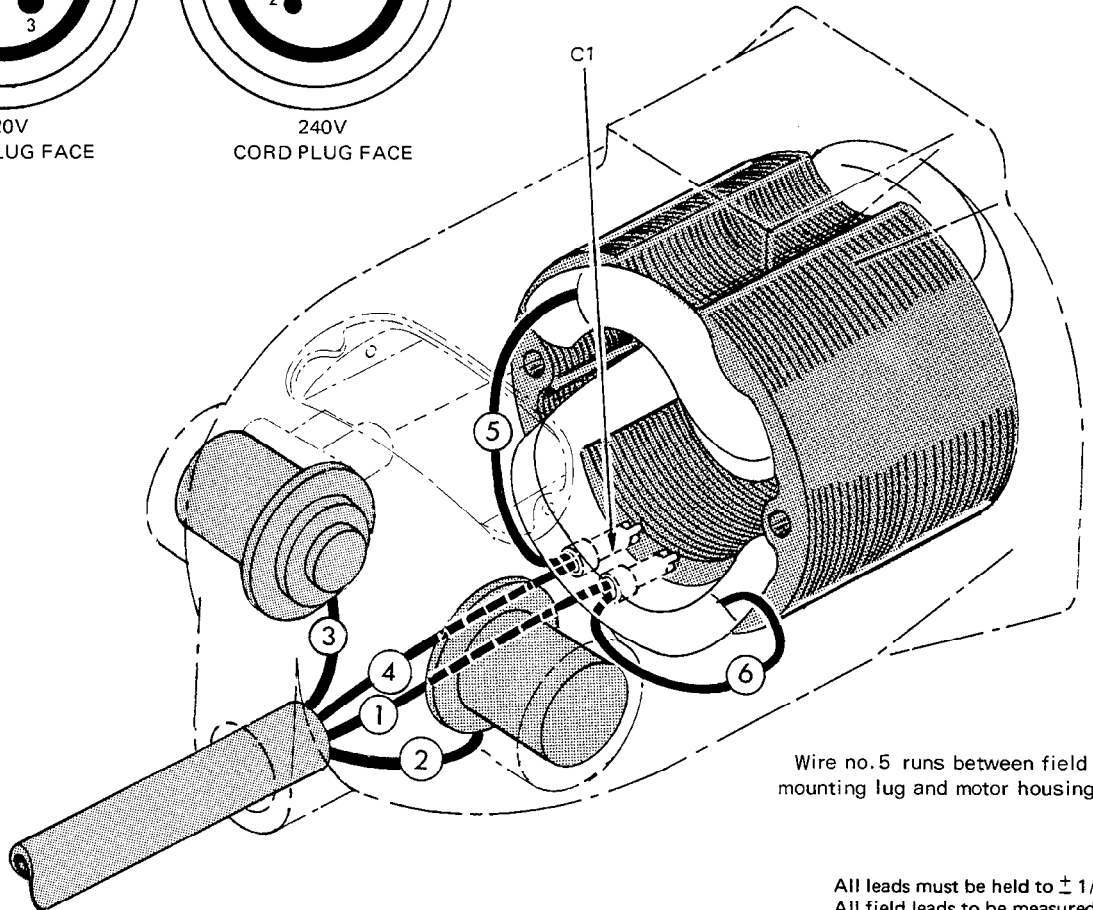

Wire no.5 runs between field mounting lug and motor housing

Refer to electrical parts chart for terminal and connector part nos.
and quantity required — see drawing for actual hook-up.

All leads must be held to $\pm 1/8''$.
All field leads to be measured from
and perpendicular to laminations.
All lead lengths are before stripping.

WIRING SPECIFICATIONS

Wire No.	Wire Color	Origin or Gauge	Length	Terminal				Connector				
				T1	T2	T3	T4	C1	C2	C3	C4	
1	WHITE	CORD	2"									
2	RED	CORD	3-3/4"									
3	BLUE	CORD	3-3/4"									
4	BLACK	CORD	2"									
5	BLACK	FIELD	6-1/2"					X				
6	YELLOW	FIELD	3-3/4"					X				

ELECTRICAL PARTS

TERMINAL DESCRIPTION		
Code	Part No.	Qty.
CONNECTOR DESCRIPTION		
Code	Part No.	Qty.
C1	22-56-0160	2
SWITCH DESCRIPTION		
Code	Part No.	Qty.

WIRING INSTRUCTIONS

TITLE

LARGE DRILL POWER UNIT

**BULLETIN
58-01-0375**

DATE
Feb. '86

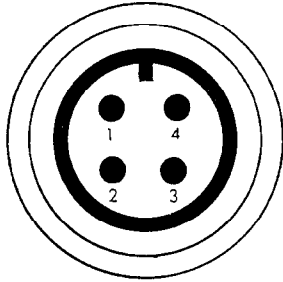

120V
CORD PLUG FACE

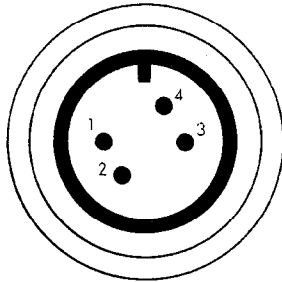

240V
CORD PLUG FACE

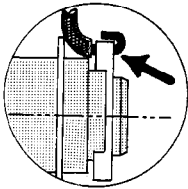

WIRE FORMING
AND SOLDER DETAIL
FOR BRUSH HOLDER
CLIP

NOTE:
Add 23-48-7382 insulation sleeving
to wire Nos. 5 & 6 after wires are
cut to length & stripped

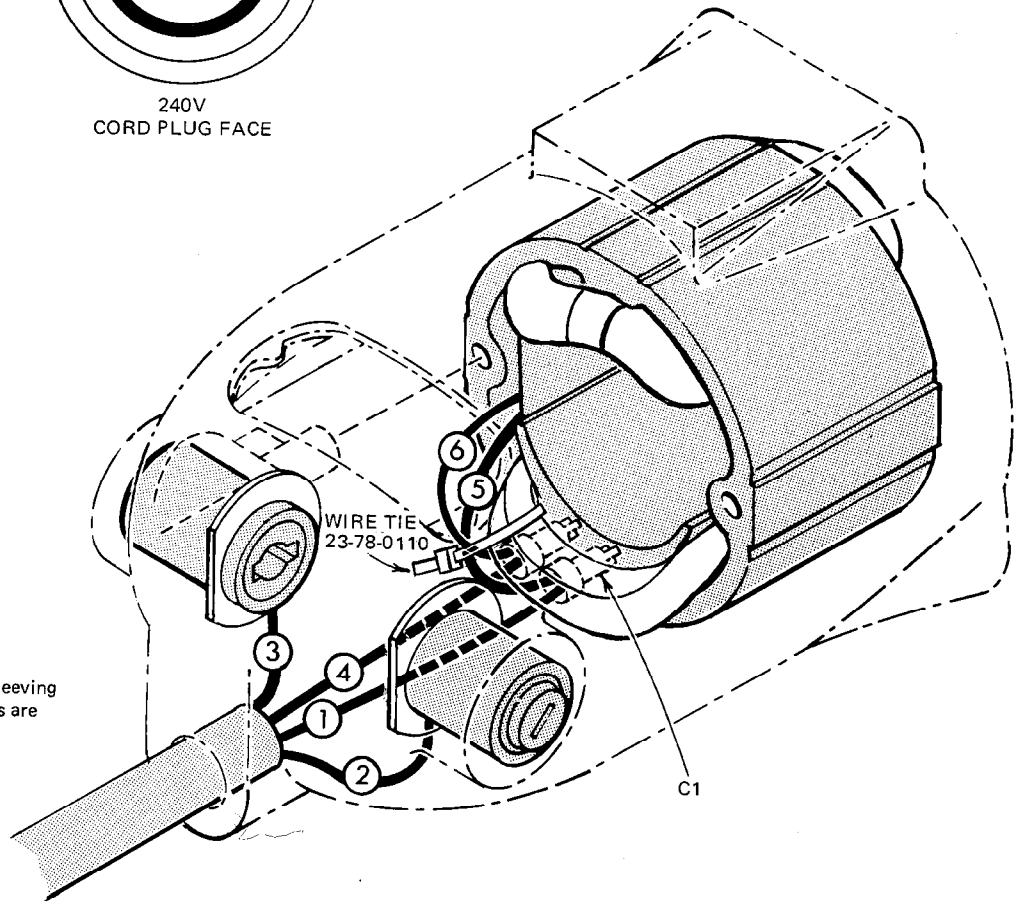

WIRING SPECIFICATIONS

Wire No.	Wire Color	Origin or Gauge	Length	Terminals, Connectors and 1 or 2 End Wire Preparation.
1	WHITE	CORD	2"	STRIP 1/2" FOR C1
2	RED	CORD	3-3/4"	STRIP 3/8" & SOLDER
3	BLUE	CORD	3-3/4"	STRIP 3/8" & SOLDER
4	BLACK	CORD	2"	STRIP 1/2" FOR C1
5	BLACK	FIELD	3-3/4"	STRIP 1/2" FOR C1
6	YELLOW	FIELD	3-3/4"	STRIP 1/2" FOR C1

NOTE:
All leads must be held to $\pm 1/8"$.
All field leads to be measured from
and perpendicular to laminations.
All lead lengths are before stripping.

TERMINAL DESCRIPTION

Code	Part No.	Qty.
C1	22-56-0160	2

CONNECTOR DESCRIPTION

Code	Part No.	Qty.

WIRING INSTRUCTIONS

TITLE

ELECTROMAGNETIC DRILL PRESS MOTORS

BULLETIN

DATE
APRIL '89

58-01-0376

NOTE:
BE CAREFUL NOT TO PINCH WIRES WHEN SNAPPING WIRE TRAP IN PLACE.

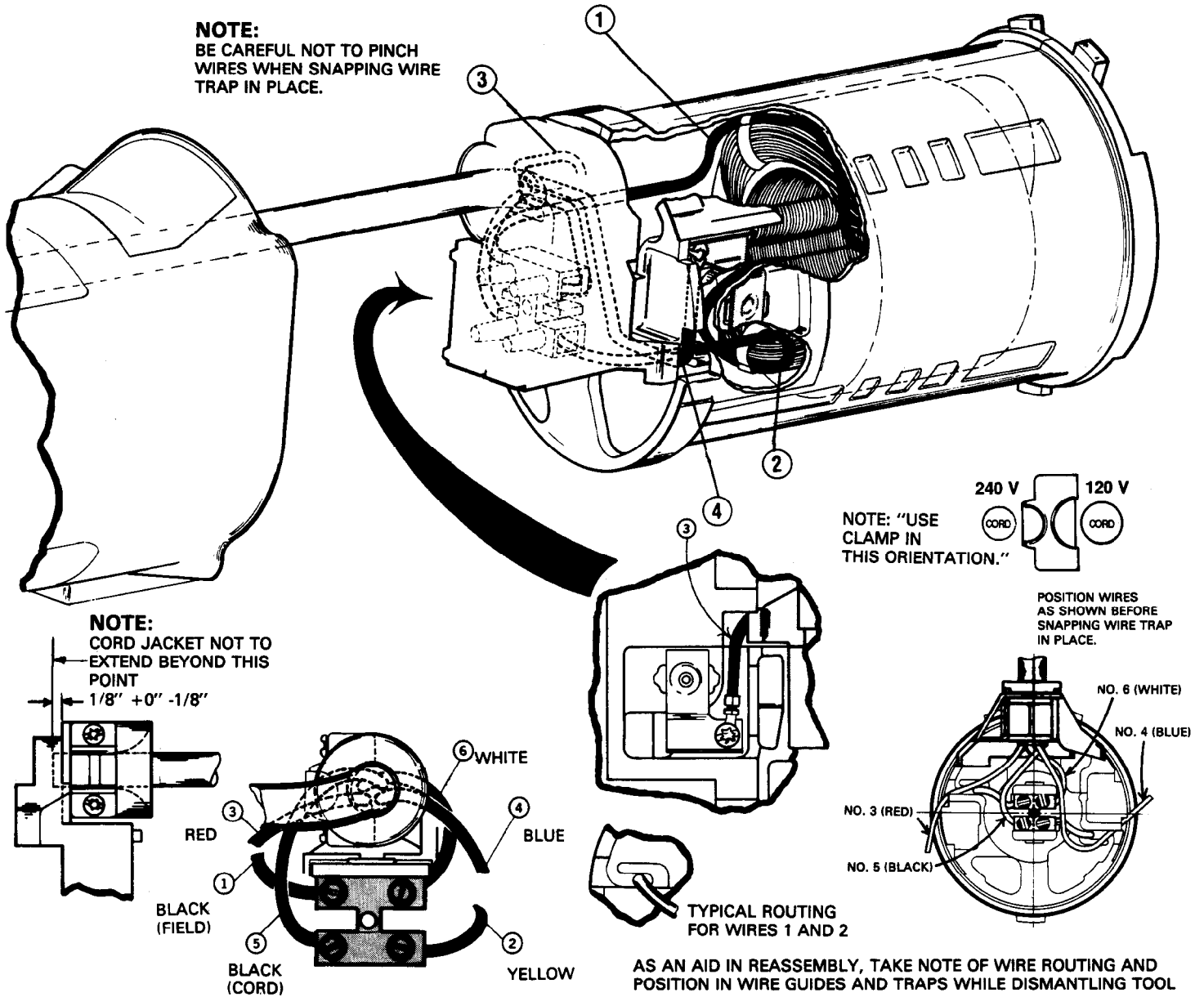

NOTE: "USE CLAMP IN THIS ORIENTATION."

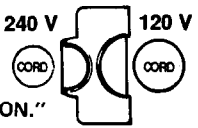

POSITION WIRES AS SHOWN BEFORE SNAPPING WIRE TRAP IN PLACE.

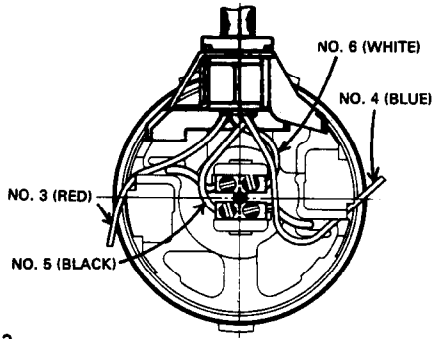

AS AN AID IN REASSEMBLY, TAKE NOTE OF WIRE ROUTING AND POSITION IN WIRE GUIDES AND TRAPS WHILE DISMANTLING TOOL

WIRING SPECIFICATIONS

Wire No.	Wire Color	Origin or Gauge	Length	Terminals, Connectors and 1 or 2 End Wire Preparation
1	BLACK	FIELD	4-15/16"	STRIP 1/4" AND TIN.
2	YELLOW	FIELD	4-15/16"	STRIP 1/4" AND TIN.
3	RED	CORD	3-3/8"	STRIP 3/16" FOR T1.
4	BLUE	CORD	5"	STRIP 3/16" FOR T1.
5	BLACK	CORD	3"	STRIP 1/4" AND TIN.
6	WHITE	CORD	2-3/4"	STRIP 1/4" AND TIN.

NOTE:
All leads must be held to $\pm 1/8"$.
All field leads to be measured from and perpendicular to laminations.
All lead lengths are before stripping.

TERMINAL DESCRIPTION

Code	Part No.	Qty.
T1	23-74-0841	2

CONNECTOR DESCRIPTION

--	--	--