



Installation and Operator's Manual:

Project ES Winch System:

PE4500 ES (PN 76-50115BW) SEC8 ES (PN 77-50141W)
SEC8 Scout ES (PN 77-53141W) SEC95 ES (PN 76-50246BW)
SEC12 ES (PN 76-50251BW) SEC15 ES (PN 76-50260W)



Table of Contents:

Safety Warnings & Precautions.....	3
Winching Tips & Techniques.....	6
Getting Started:	
Unpacking Your Winch.....	8
Winch Mounting.....	8
Clocking Instructions.....	9
Control Box Installation.....	10
Winch Operation.....	14
Maintenance.....	15
Troubleshooting.....	15
Features.....	16
Parts Lists.....	19



Safety Warnings

When using this winch, safety precautions should always be followed to reduce the risk of personal injury and damage to the winch.

1) **LEARN TO USE YOUR MILE MARKER WINCH:**

a. After winch has been installed, take some time and practice using it so you will be familiar with ALL OPERATIONS. Periodically check the winch installation to ensure that all bolts are tight.

b. To ensure proper operation, carefully inspect for any damaged parts before operating the winch.

2) **KEEP WINCHING AREA CLEAR:**

Do not allow people to remain in the area during winching operations. Do not step over a taut wire rope or allow anyone else to do so. Due to the possibility of cable failure, direct all personnel to stand clear of any possible pathway. A snapped cable could cause winch failure, injury or death. Keep proper footing and balance at all times. Do not reach over or across the winch and/or pulling cable while the winch is in operation.

3) **INSPECT CABLE/ROPE AND EQUIPMENT FREQUENTLY**

The cable/rope should be inspected for damage frequently. A frayed cable/rope with broken strands should be replaced immediately. Always replace the cable/rope with an acceptable substitute. The substitute must be IDENTICAL in strength and quality, equal to the original supplied equipment. Cable and Rope does not have the same characteristics. Periodically you need to check how the cable/rope is wrapped on the winch drum. Make sure the cable/rope is not penetrating lower wraps as it transitions from one layer to the next. This condition may cause excessive force on drum flange (left & right).

4) **WORKING AREA CONDITIONS:**

Keep the working area well lit. Do not use this winch in the presence of flammable gases or liquids.

5) **KEEP CHILDREN AWAY:**

Keep children away from working area. Never let children operate the winch.

6) **DRESS PROPERLY:**

Do not wear loose clothing or jewelry as they can be caught in moving parts. Protective, electrically non-conductive clothes and non-skid footwear is the only type of clothing you should be using when operating the winch. Wear restrictive hair covering to contain long hair.

7) **USE LEATHER GLOVES:**

When handling or rewinding wire rope always use hand protection to eliminate the possibility of cuts caused by burrs & slivers from broken strands.

8) **DRUM ROPE**

Before winching always make sure there is at least 5 complete turns of cable left on the drum or 10 complete turns of rope left on the drum.

9) **KEEP HANDS AND FINGERS CLEAR OF WIRE ROPE AND HOOK WHEN OPERATING WINCH:**

Never put your finger through the hook when reeling in the last few feet. If your finger should become trapped in the hook or rope, you could lose your finger. Never guide a wire rope under tension onto the drum with your hand.

10) **NEVER HOOK THE ROPE BACK ONTO ITSELF:**

Hooking the rope back onto itself creates an excessive strain that could break individual strands; this, in effect, weakens the entire wire rope.

11) **KEEP PULLING DURATIONS AS SHORT AS POSSIBLE:**

The winch is designed for intermittent use and cannot be used in constant duty applications. Do not pull more than one minute at or near rated load. If the motor becomes too hot to touch, stop and let it cool down. If the motor stalls, cut off the power immediately.

Safety Warnings-Cont'd

When using this winch, safety precautions should always be followed to reduce the risk of personal injury and damage to the winch.

12) DO NOT OVERLOAD:

For your safety and efficient performance, always use this winch at or under its rated capacity for your safety and for better performance. Do not use inappropriate attachments in an attempt to exceed its rated capacity.

13) AVOID CONTINUOUS PULLS FROM EXTREME ANGLES:

This will cause the rope to pile up at one end of the drum. When possible, please get the rope as straight as possible to the direction of the object.

13.B) INSPECT WINCH ROPE LINE AND RELOAD ROPE AFTER EACH RECOVERY

14) NEVER OPERATE THE WINCH WITHOUT THE CABLE/ROPE FAIRLEAD FITTED

Operator injury or winch damage can result if a fairlead is not installed.

15) STAY ALERT:

Watch what you are doing. Use your common sense. Do not use this winch when you are tired, stressed or **WHEN UNDER THE INFLUENCE OF DRUGS, ALCOHOL OR MEDICATION.**

16) DISCONNECT REMOTE CONTROL:

Unplug the winch's remote control when not in use.

17) REPLACEMENT PARTS & ACCESSORIES:

When servicing, use only identical replacement parts. Usage of any other parts will void the warranty. Approved accessories are available from your local distributor.

Precautions

When using this winch, safety precautions should always be followed to reduce the risk of personal injury and damage to the winch.

- 1) Keeps hands and body away from Fairlead (cable intake slot) when operating.
- 2) Secure vehicle in position before using winch.
- 3) Do not exceed winch load weight capacity (see Winch Specifications).
- 4) Be certain winch is properly bolted to a structure (or vehicle) that can hold the winch load.
- 5) Always use proper couplings when connecting winch cable hook to load.
- 6) Do not lift items vertically. The winch was designed for horizontal use only.
- 7) Do not overload the winch (see Model Specifications). It will do the job better at the load it was intended.
- 8) Do not use inappropriate attachments to extend the length of the winch cable.
- 9) **NEVER LIFT PEOPLE OR HOIST LOADS OVER PEOPLE.**
- 10) Never come in between the winch and the load when operating.
- 11) Do not apply load to winch when cable is fully extended. Keep **AT LEAST 5 FULL TURNS** of cable on the drum. **10 FULL TURNS of the rope on the drum**
- 12) After moving an item with the winch, secure the item. Do not rely on the winch to hold it for an extended period.
- 13) Examine winch before using. Components may be affected by exposure to everyday weathering, chemicals, salts, and rust.
- 14) When loading a boat into a trailer without reel or side hull rollers, make sure the trailer is submerged in the water when the boat is loaded by the winch. Attempting to drag the boat on to the trailer while on land can cause winch failure and possible injury.
- 15) Never operate winch if cable shows any signs of weakening, is knotted or kinked.
- 16) Do not cross over or under the cable while it is in process of loading.
- 17) Do not move vehicle with cable extended and attached to load to pull it. The cable could snap.
- 18) Apply blocks (such as a wheel choke) to vehicle when parked on an incline.
- 19) Re-spool cable properly.

Winching Tips & Techniques

WINCHING TIPS AND USE OF A SNATCH BLOCK

- Use OEM tow hooks, recovery eyes or a clevis mount for attachment of a tow strap or winch cable. Warning: Never use a ball and/or ball mount as an anchor point for tow strap or winch cable. Severe personal injury or death could occur.
- Always heed all winch manufacturer's recommendations, cautions, and warnings.
- Attach return cable to tow hook or recovery eye when using a snatch block. Always use a clevis to secure snatch block to strap, or severe damage could occur to persons and vehicle. (See Figure Below). Caution: Never attach return cable to winch mount. This may overload winch mount and/or front receiver.

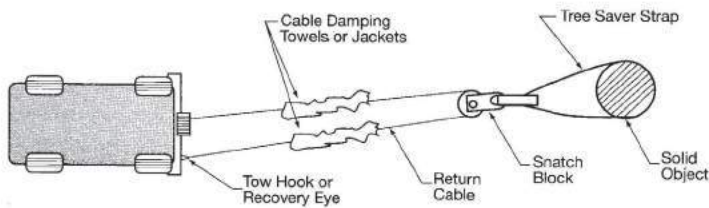

RATING

For maximum line pull rating, winch cable direction must not exceed:

1. 15° angle up or down from horizontal (See Figure Below).
2. 45° angle left or right from straight ahead (See Figure Below).

Caution: Exceeding the maximum line pull rating may overload winch, winch mount, and/or front mounted receiver.

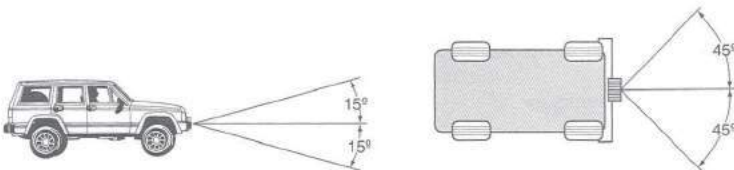

SAFETY TIPS

- NEVER DISENGAGE CLUTCH LEVER WHEN THERE IS A LOAD ON THE WINCH. Mile Marker electric winches utilize an automatic load holding brake, therefore no adjustment to clutch is needed to maintain load.
- Store the remote control cord in a safe place when not in use to prevent use by children or other unauthorized persons who could injure themselves or others or damage the controls.
- Do not operate winch under the influence of drugs, alcohol, or medications.
- Isolate winch before putting hands in or around the fairlead or wire rope drum (The Danger Zone).
- DO NOT OVERLOAD YOUR WINCH. Do not maintain power to the winch if the drum stops. Overloads can damage the vehicle, winch or winch rope and create unstable operating conditions.
- It is recommended to lay a heavy blanket or jacket over the rope about halfway along to the hook attachment. If a rope failure should occur, the weight of the cloth will act as a damper and help prevent the broken rope from whipping (See Figure Below). Remember to move the blanket or jacket as winching proceeds, but halt winching when doing so. Partially raising the hood of the vehicle will also give a measure of protection to its occupants from broken rope or cable, consistent with sufficient forward visibility for the operator.

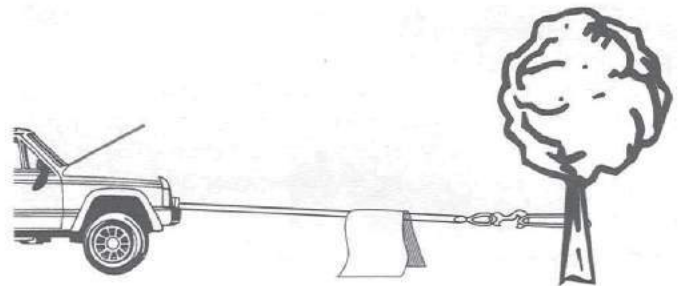

Winching Tips & Techniques

SELF-RECOVERY

1. Always attempt to get the cable as straight as possible to the direction of the vehicle. It is acceptable to start a pull at an angle if it is obvious that the vehicle will turn towards the hook anchoring point. Turning the steering wheel will assist the process. It is recommended that the driver is in the vehicle.
2. Make sure hand brake and foot brake are free and that the transmission is in neutral.
3. When the driver's attempt to regain vehicle traction is successful, he or she should be careful not to overrun the cable and risk the possibility of it being trapped under the vehicle.
4. DO NOT move your vehicle in reverse to assist the winch. The combination of the winch and vehicle pulling together could overload the cable and winch itself.

USE OF A PULLEY BLOCK OR SNATCH BLOCK

Vehicle self-recovery using the pulley block attached to the anchor point for direct pull. In this instance the vehicle becomes the "load" and the actual pulling power on the vehicle will be double at half winch rope speed. Never connect wire rope or hook back to winch mount!

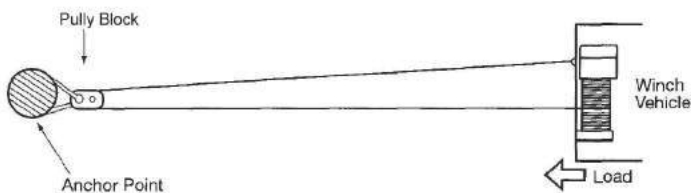

Below: Direct pull on load using the winch vehicles as the anchor with pulley block attached to the load.

The most important aid to successful winching (after the winch) is the pulley block, which can be used to increase the pulling power of the winch or for indirect pulls. Pulley blocks can be used in two modes. First mode is attached to the load and second is secured to an anchor point.

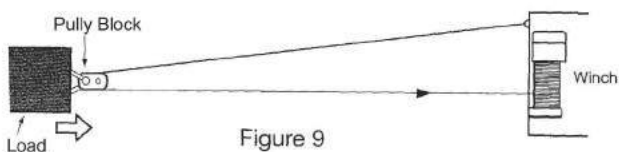

Below: Indirect pull necessitated by obstructions or soft ground. Pulley block attached to load using a suitable anchor point. Note the angled direction taken by the load and subsequent angle of rope feed-back on the winch drum (extreme example shown). There may be unavoidable circumstances requiring this mode, though in general it is not recommended unless applied in stages by moving the anchor point or vehicle to avoid the sharp angled rewind on the winch drum. The actual load pulling power and rope speed will depreciate with any increased angle between the ropes.

The anchor point, when used must be secure, using a tree, another vehicle or any firm structure to which a pulley block can be used to your advantage.

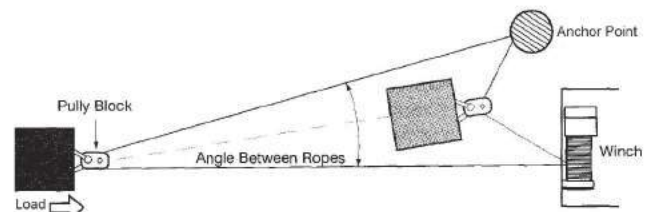

USE OF A NYLON SLING AND SHACKLE

- A shackle should always be used when attaching winch hooks to nylon slings. NOTE: The shackle must pass through both eyes of the sling. The safe working load of the nylon sling is based on the use of both eye ends. Never use the cable or hook to connect directly to the nylon sling.

USE OF GLOVES

- When handling or rewinding the cable always use gloves to eliminate the possibility of cuts caused by burrs and broken strands. Inspect cable and equipment frequently. The cable should be replaced immediately if any sign of burrs or broken strands are evident. A frayed cable with broken strands should be replaced immediately. Always replace the cable with a Mile Marker recommended replacement part. Any substitution must be IDENTICAL in strength, quality, lay and stranding. Never hook the cable back onto itself. Hooking the cable back onto itself creates an unacceptable strain, breaking individual strands which in turn weakens the entire cable. Use a sling. Avoid continuous pulls from extreme angles as this causes cable to pile up at one end of the drum.

Getting Started

Unpacking Your Winch

- Unpack your new Mile Marker winch and ensure that all the parts are included by referring to parts list and exploded view drawings provided in this manual.

NOTE: If you find any missing or broken parts, please call Mile Marker as soon as possible at the number present on the cover page of this manual.

Winch Mounting

NOTE: Mile Marker recommends the use of its mounting systems for proper winch installation and optimum winch performance. However, when not using Mile Marker Mounting System, ensure that the mounting platform is strong enough to meet the maximum rated load of the winch in use. Mile Marker recommends steel plates with thickness of at least 0.25”.

Your Winch should be aligned and secured to a solid part of the vehicle (front or rear) where the full rated load will be evenly distributed.

CAUTION: It is essential that the mounting surface be flat and the winch is mounted such that the three major sections (Gear housing end, drum and motor end) are in proper alignment.

1. Drill four mounting holes (10mm in Dia.), if necessary, according to the bolt pattern mentioned in the winch specifications.
2. Fasten the winch body to the mounting platform using the four Capscrews (M10 X 34mm) and Nuts (M10) provided.
3. Torque the Capscrews to about 35 ft-lb (47.5 N-m).
4. All Mile Marker Mounting Systems come predrilled with fairlead holes. If you are using any other mounting platforms, drill two holes for the roller fairlead installation. Position the holes such that the fairlead opening hole stretches from the circumference of the drum to the end of the maximum permissible layers on the drum in the direction cable is being rolled.

CAUTION: When replacing the capscrews or when longer bolts are required, make sure that you use bolts of Grade 5 or greater.

Clocking Instructions

Clocking Instructions

Winch gear housing can be clocked in 8 positions enabling the user to position the clutch lever at 8 equidistant locations (0°, 45°, 90°....360°).

1. Remove Gear Housing from Tie Bars (Fig. 1-2).
2. Remove the 8 bolts in the Gear Housing Leg (Fig. 1-3).
3. Separate Leg and Gear Housing. A slight tap with a hammer might be needed (Fig. 1-4).
4. Place Gear Housing Leg in the angle desired and screw in bolts (Fig. 1-5). Torque to spec.
M4 X 12 (Item #2*): 2 ft-lb
M8 X 25 (Item #6*): 18 ft-lb
M6 X 12 (Item #40*): 7.5 ft-lb
M5 X 16 (Item #41*): 4.5 ft-lb
5. Properly slide Drive Shaft in the Gear Housing and line Drum into Drive Gear (Fig. 1-6).
6. Re-attach Tie Bars to Gear Housing Leg by using the same process as step 1, in reverse order (Fig. 1-2).

* Item numbers reference the parts breakdown pages.



1-1: Clocking Positions: 0° and 45°



1-2: Unscrew and remove Gear Housing from Tie Bars.

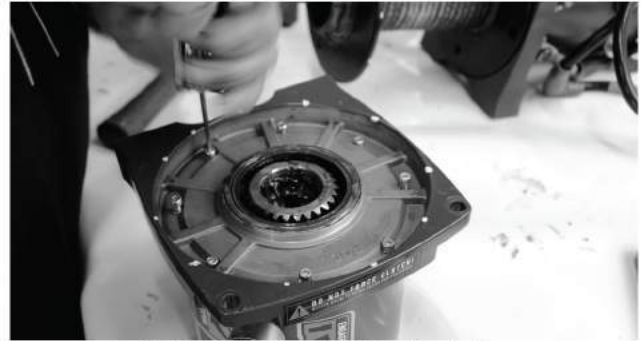

1-3: Remove the 8 bolts in the Gear Housing Leg.



1-4: Separate Leg and Gear Housing.



1-5: Place Gear Housing Leg in the angle desired, and screw in bolts.

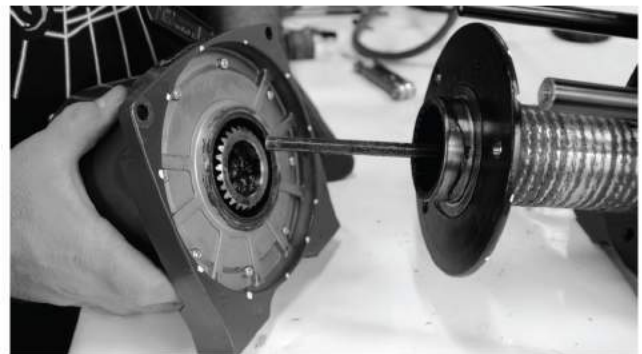

1-6: Slide Drive Shaft in the Gear Housing and line Drum into Drive Gear.

Control Box Installation

NOTE: Your Mile Marker Control Box can either be mounted to the winch or in a remote location. However, Mile Marker recommends you to mount it to the winch following the instructions below. If you choose to mount it in a remote location, please ensure that: (a) the location does not interfere with any vehicle's moving/functioning parts, and (b) you use electrical cables with similar or better specifications as that provided by Mile Marker.

SEC Series Control Box Installation

You will need a 14mm wrench, 10mm wrench, a metric Allen wrench set and a pair of snips. Also you will need general hand tools for mounting the winch. Your Project ES control box can be mounted over the winch motor, or over the tie bars. This decision is usually based on mounting constraints, and personal preference.

Figure 2-1 shows the control box and mounting hardware included in your new winch box.

Mounting Control Box on Motor

If you choose to mount your control box on the winch motor, please follow the following steps.

1. Mount the control box to mounting brackets using 10 mm wrench (Fig 2-2 & 2-3).
2. With mounting bracket attached to control box, locate the mounting points on the side of the motor die casting (Fig. 2-4).
3. With the control box placed on the motor, screw in the bolts to the mounting points (Fig. 2-5).
4. Attach the Tie Wrap around the small bracket to hold it down and clip the excess length (Fig. 2-6 & 2-7).



2-1: Control Box and Tools Needed: 14mm & 10mm Wrench, Metric Allen Wrench Set



2-2: Install the mounting bracket to the bottom of the control box with a 10mm wrench.



2-3: Install the smaller mounting bracket on the other side.



2-4: These are the mounting points where the bracket will be screwed in.

Control Box Installation Cont'd

Mounting Control Box on Motor Cont'd



2-5: Screw bolts with control box in the mounting points.



2-6: Attach Tie Wrap

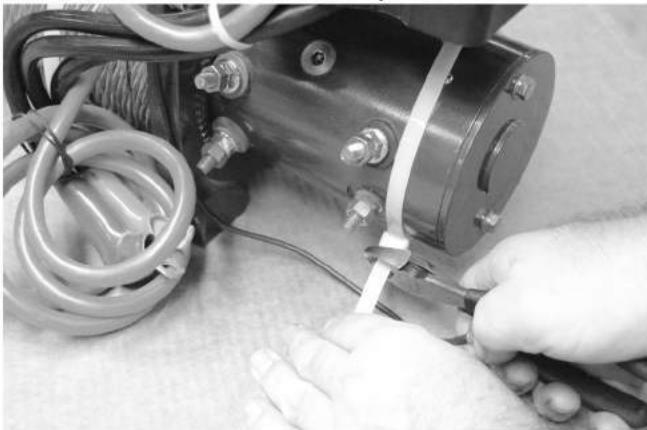

2-7: Clip Excess Length

Control Box Installation Cont'd

Mounting Control Box on Tiebars

1. Mount the control box to mounting brackets using 10 mm wrench (Fig 2-8).
2. Mount control box on the tie bars by attaching front end first and pushing down to snap in the back end (Fig. 2-9).
3. Locate the two extra pieces for the tie bars mounting brackets (Fig. 2-10).
4. Screw in these pieces to the rear side of the tie bar bracket using a Philips Head Screw Driver (Fig. 2-11).



2-8: Install the mounting bracket to the bottom of the control box with a 10mm wrench.



2-9: Mount Control Box on the Tie Bars.



2-10: Locate the extra pieces for the Tie Bar Mountin Brackets.



2-11: Screw in pieces to the rear of the Brackets.

Control Box Installation Cont'd

Wiring the Control Box

1. Slips the boots onto pertinent cables and make electrical connection in accordance with the schematic on following page. Slide the boots onto all the electrical connections made (figs. 2-12 through 2-14).
2. Run battery power cables carefully under hood of vehicle, avoiding interference with moving parts and abrasion points which could potentially cause electrical short.
3. Attach Black Cable to Negative Battery Terminal (-), followed by Red Cable to Positive Battery Terminal (+) (fig. 2-14). Refer to Winch Operation Section of this manual for proper functioning; if drum rotates in the incorrect direction when "IN" button is pressed, green and yellow motor cables need to be switched.

CAUTION: Do Not Connect Cables to Battery until unit is completely wired to control box and installed on vehicle. Reserve for last step of installation.

CAUTION: Make sure that all exposed electrical connections are covered with insulation boots to avoid electrical short. Battery cables should not be drawn taut; leave some slack for cable movement. Also, ensure that they are routed properly with out any interference with the vehicular components that could potentially damage the cable or cause electrical short. Long battery cable runs may have significant voltage drops that may cause the winch motor controller to not operate.

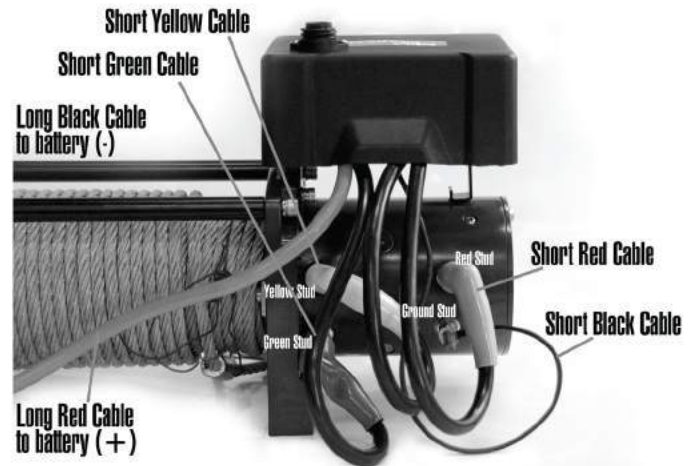

2-12: Complete Wiring Schematic: SECB

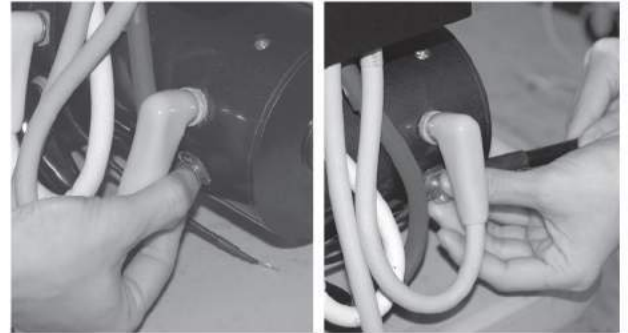

2-13: Black Cables (ground): Remove bolt, Attach both large and small cables, and return bolt to motor.

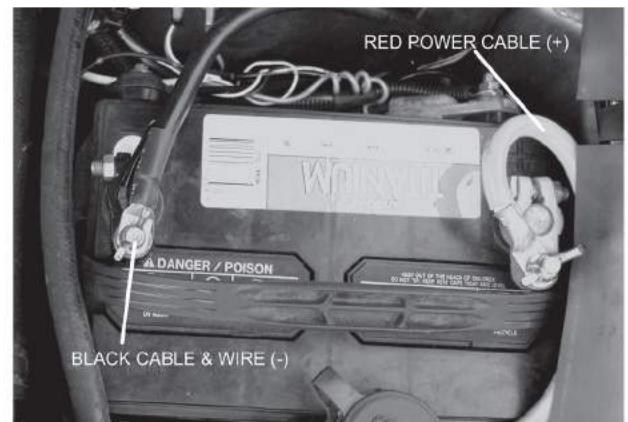

2-14: Complete Wiring to Battery

CAUTION: Do Not Connect Cables to Battery until unit is completely wired to control box and installed on vehicle. Reserve for last step of installation.

Winch Operation:

NOTE: For optimal winch performance, it is recommended that you use a fully charged 12V battery with at least 650 Cold Cranking Amperes. Further, it is advised to keep the engine running during the winch operation, so that the battery is being charged continuously.

All Mile Marker winches are equipped with a Clutch Lever that engages / disengages the clutch. Clutch, when engaged, will couple the gear train with winch drum; this is also known as Locking of the winch. The Clutch, when disengaged, de-couples the gear train from the winch drum enabling the drum to rotate independently; this is also called Freespooling the winch.

CAUTION: Before you start using your new Mile Marker winch, you will have to re-wind the entire cable on the drum under a load of at least 500 lbs (227 Kg) starting with at least 5 wraps on the initial layer. Failure to do so will result in the outer wraps pressing against the inner wraps resulting in the damage of the cable.

Always have at least 5 wraps of cable on the winch drum before winching.

Always ensure that the clutch is fully engaged or fully disengaged to avoid any injuries and damages.

All electric winches are for intermittent use only. Never run the winch for more than 1 min at maximum rated load. Wait until the motor cools down before resuming winching operation. Usage of a snatch block is recommended to reduce the load on the winch motor.

All Mile Marker Electric Winches feature an Automatic Load Holding brake; so never run the winch against the brake (OUT on the hand control) for more than 10 seconds. Failure to do so might result in damage to the brake and motor.

Always stay clear of the loaded winch cable.



3-1: Clutch Engagement: SEC (ES) Models



3-4: Remote Control Function Diagram

Operational Instructions

1. Disengage the clutch by moving the Clutch Lever to Disengage Position (or Freespool mode) (Fig. 3-1).
2. Free Spool the cable and connect to the desired anchor point (self recovery) or vehicle being recovered.
3. Fully Engage the clutch by moving the Clutch Lever to Engage Position (Fig. 3-1).
4. Lift the protective boot covering the hand control plug-in. Insert the hand control plug.
5. Rotate the red Kill Switch from the "OFF" position, to the "ON" position. (Figs. 3-2 & 3-3).
6. Start winching IN (Figs. 3-4) to remove the slack on the cable, ensuring that the cable is winding onto the drum properly (with out any overlapping or gaps). Never disengage the clutch while the cable is under load!
7. When finished winching, let off the load by winching OUT. With adequate slack created, unhook the cable and re-wind the cable onto the drum.
8. Turn Red Kill Switch back to the "OFF" position. Unplug the hand control and push the protective boot cover back on to the Plug-in.

Winch Maintenance

- All moving parts within the Electric Winch have been lubricated using high temperature lithium grease at the factory. No further internal lubrication is required for the life of the winch.
- Lubricate the cable periodically using light penetrating oil.
- Electrical connections may corrode over a period of time due to environmental changes. This may result in reduced performance of the winch or even possible electrical shorting. Hence, always clean the electrical connections before and after using the winch.
- After every use of the winch, inspect the cable for damages such as kinks, broken strands etc. When damaged, replace the cable immediately!

CAUTION: It is recommended that you replace the cable with superior Mile Marker cables. If replacing from other sources, carefully compare for the maximum load capacity of the cable with that mentioned in the Specifications Section of this manual.

Troubleshooting

SYMPTOM	POSSIBLE CAUSE	SUGGESTED REMEDY
Motor does not turn on	Safety switch is OFF	Turn safety switch to ON position.
	Switch Assy not connected properly	Insert Switch Assy firmly to the connector.
	Loose battery cable	Tighten nuts on cable connectors
	Solenoid malfunctioning	Tap solenoid to free contact, applying 12 volts to coil terminal directly. Makes an audible clicking when activating.
	Defective Switch Assembly	Replace Switch Assy.
	Defective motor	Check for voltage at armature port with switch pressed. If voltage is present, replace motor.
	Water has entered motor	Drain and dry. Run in short bursts without load until completely dry.
Motor runs too hot	Long period of operation	Let winch cool down periodically.
Motor runs slowly or without normal power	Battery runs down	Recharge battery by running vehicle's engine.
	Insufficient current or voltage	Clean, tighten or replace the connector.
Motor runs but cable drum does not turn	Clutch not engaged	Ensure lever is completely in "engaged" position. If that does not work, contact qualified technician to check and repair.
Motor runs in one direction only	Defective or stuck solenoid	Tap solenoid to free contacts. Repair or replace solenoid.
	Defective Switch Assy	Replace Switch Assy

Winch Features and Specs: SEC8 (ES)



Features: Clockable Clutch, Planetary Gear System, Automatic Load Holding Brake, Free Spooling, Power In & Power Out, Low Electric Current, Galvanized Roller Fairlead, Series Wound Motor

Specifications:

Part Number	77-50141W
Rated line pull (single line)	8,000 LBS (3629 kg)
Gear Train	3 Stage Planetary
Gear Ratio	150:0
Motor	Series Wound 4.9HP (3.6KW), 12V DC
Control Pendant	Power In, Power Out Remote, 12' (3.7 m)
Dimensions (LxWxH)	20.8" x 6.34" x 7.86" (528 x 161 x 200mm)
LINE	21/6.4" x 92' (nominal 14,400 lbs, 6531 kg) (8.53mm x 30.5m)
Drum Size: Diameter/Length	2.5" x 8.35" (63" x 222 mm)
Net weight	54 lbs (24.49 kg)
Bolt Pattern	10" x 4.5" (254MM X 114MM) (4 bolts, 3/8")

Performance:

Line Pull		Line Speed		Motor
lbs.	kgs.	fpm	mpm	amps@12v
0	0	26	7.9	95
2000	908	20	6	175
4000	1816	14	4.3	240
6000	2724	12	3.8	295
8000	3632	10.8	3.3	370

Winch Features and Specs: SEC8 (ES)



Features: Clockable Clutch, Planetary Gear System, Automatic Load Holding Brake, Free Spooling, Power In & Power Out, Low Electric Current, Synthetic Rope with Heat Sheath, Anodized Hawse Fairlead, Series Wound Motor

Specifications:

Part Number	77-53141W
Rated line pull (single line)	8,000 LBS (3629 kg)
Gear Train	3 Stage Planetary
Gear Ratio	152:1
Motor	4.8 HP Series Wound (3.6KW) 12V DC
Control Pendant	Power In, Power Out Remote, 12' (3.7 m)
Dimensions (LxWxH)	21.5" X 6.25" X 8.0" (546.1 MM X 158.8 MM X 203.2 MM)
Synthetic Rope	5/16" x 100' (13,700 nominal) (7.94 MM X 30.5M)
Drum Size: Diameter/Length	2.5" (6.4 cm)/9" (23cm)
Net weight	70 lbs (31.75 kg)
Bolt Pattern	10" x 4.5" (254MM X 114MM) (4 bolts, 3/8")

Performance:

Line Pull		Line Speed		Motor
lbs.	kgs.	fpm	mpm	amps@12v
0	0	26	7.9	95
2000	907	20	6	175
4000	1814	14	4.3	240
6000	2722	12	3.8	295
8000	3629	10.8	3.3	370

Winch Features and Specs: SEC95 (ES)



Features: Clockable Clutch, Planetary Gear System, Automatic Load Holding Brake, Free Spooling, Power In & Power Out, Low Electric Current, Galvanized Roller Fairlead, Series Wound Motor

Specifications:

Part Number	76-50246BW
Rated line pull (single line)	9,500LBS (4082kg)
Gear Train	3 Stage Planetary
Gear Ratio	210:0
Motor	Series Wound 4.9HP (3.6kW), 12/24V
Control Pendant	Power In, Power Out Remote, 12' (3.7 m)
Dimensions (LxWxH)	20.8" x 6.34" x 7.86" (528 x 161 x 200mm)
Cable	21/6.4" x 92" (nominal 14,400 lbs, 6531 kg) (9.53mm x 30.5m)
Drum Size: Diameter/Length	2.64" x 8.7" (67 x 222mm)
Net weight	86 lbs (39 kg)
Bolt Pattern	4 Bolt Pattern, 4.5" X 10", (114.3 mm X 254 mm)

Performance:

Line Pull		Line speed		Motor Current
lbs.	kgs.	fpm	mpm	amps@12v
0	0	21	7.8	85
2000	908	11	4.6	150
4000	1816	8.8	3.2	210
6000	2724	7.5	2.4	234
8000	3632	6	1.8	252
9500	4313	4.3	1.3	375

Winch Features and Specs: SEC12 (ES)



Features: Clockable Clutch, Planetary Gear System, Automatic Load Holding Brake, Free Spooling, Power In & Power Out, Low Electric Current, Galvanized Roller Fairlead, Series Wound Motor

Specifications:

Part Number	76-50251BW
Rated line pull (single line)	12 000 LBS (5443 kg)
Gear Train	3 Stage Planetary
Gear Ratio	294:1
Motor	Series Wound 4.9HP (3.6kW), 12/24V
Control Pendant	Power In, Power Out Remote, 12' (3.7 m)
Dimensions (LxWxH)	20.8" x 6.34" x 7.86" (528 x 161 x 200 mm)
Cable	3/8" x 92" (nominal 14,400 lbs, 6531 kg) (9.53mm x 30.5m)
Drum Size: Diameter/Length	2.64" x 8.35" (67 x 212mm)
Net weight	86 lbs (39 kg)
Bolt Pattern	4 Bolt Pattern, 4.5" X 10", (114.3 mm X 254 mm)

Performance:

Line Pull		Line speed		Motor Current
lbs.	kgs.	fpm	mpm	amp
0	0	16.4	5	85
4000	1816	8.8	2.7	160
6000	2724	7.5	2.3	191
8000	3632	6.7	2	235
10000	4540	5.6	1.7	270
12000	5448	4.9	1.5	300

Winch Features and Specs: SEC15 (ES)



Features: Clockable Clutch, Planetary Gear System, Automatic Load Holding Brake, Free Spooling, Power In & Power Out, Low Electric Current, Galvanized Roller Fairlead, Series Wound Motor

Specifications:

Part Number	76-50260W
Rated line pull (single line)	15,000 LBS (6803 kg)
Gear Train	3 Stage Planetary
Gear Ratio	294 : 1
Motor	Series Wound, 7.3 HP (5.5 kW), 12 Volt 24 Volt available
Control Pendant	Power In, Power Out Remote, 12' (3.7 m)
Dimensions (LxWxH)	20.8" x 6.3" x 8.3" (528 x 160 x 211 mm)
Cable	7/16" x 65' (11 mm x 20 m)
Drum Size: Diameter/Length	3" x 9"
Net weight	90 lbs (40.8 kg)
Bolt Pattern	4 Bolt Pattern, 4.5" X 10", (114.3 mm X 254 mm)

Performance:

lbs	kgs	fpm	mpm	amp
0	0	16.7	5	120
4000	1816	12	3.7	202
6000	2724	10.5	3.2	225
8000	3632	9.2	2.8	250
10000	4540	7.9	2.4	310
12000	5448	6.6	2	355
15000	6810	5.9	1.8	420

Winch Features and Specs : SEC4500 (ES)



Features: Clockable Clutch, Planetary Gear System, Automatic Load Holding Brake, Free Spooling, Power In & Power Out, Low Electric Current, Galvanized Roller Fairlead, Series Wound Motor

Specifications:

Part Number	76-50115BW
Rated line pull (single line)	4,500 LBS (2041 kg)
Gear Train	3 Stage Planetary
Gear Ratio	150 : 1
Motor	Series Wound 3.7HP (2.7kW), 12v DC
Control Pendant	Power In, Power Out Remote, 12' (3.7 m)
Dimensions (LxWxH)	17.32" x 6.34" x 7.86" (440 x 161 x 200 mm)
Cable	1/4" x 80" (nominal 7000 lbs, 3175 kg) (6.35mm x 24.5m)
Drum Size: Diameter/Length	2.59" x 9" x 7.86" (66.3 x 228 mm)
Net weight	51 lbs. (23 kg) (with mounting bracket)
Bolt Pattern	6.535" x 4.5" (4 bolts) (165.9 mm X 114.3 mm)

Performance:

Line Pull		Line Speed		Motor
lbs.	kgs.	fpm	mpm	amps@12v
0	0	14	4.3	35
1500	380	6.6	2	80
2200	998	5.2	1.6	100
3000	1361	4.6	1.4	145
4500	2041	3.3	1	170

Parts Breakdown & Assembly - SEC8 (ES)

Item	Quantity	Part Number	Description
1	1	77-50141W-01	Dry Bearing
2	16	77-50141W-02	Screw M4 × 12
3	16	77-50141W-03	Spring Washer M4
4	1	77-50141W-04	End Bearing
5	4	77-50141W-05	Spring Washer M8
6	4	77-50141W-06	Screw M8 × 25
7	2	77-50141W-07	Gasket
8	1	77-50141W-08	Clutch Handle
9	1	77-50141W-09	Seal
10	1	77-50141W-10	Spring Washer
11	1	77-50141W-11	Gear Ring
12	1	77-50141W-12	Retaining Screw
13	1	77-50141W-13	Gear Ring-input/intermediate
14	1	77-50141W-14	Gear Carrier Assy-output
15	1	77-50141W-15	Gear Carrier Assy-intermediate
16	1	77-50141W-16	Gear Carrier Assy-input
17	1	77-50141W-17	Gear-input sun
18	1	77-50141W-18	Gear Bushing
19	1	77-50141W-19	Gear Box Cover
20	2	77-50141W-20	Spacer
21	2	77-50141W-21	Ring
22	2	77-50141W-22	Seal Ring
23	1	77-50141W-23	Drum Assy
24	1	77-50141W-24	Screw
25	1	77-50141W-25	Cable Anchor

Item	Quantity	Part Number	Description
26	1	77-50141W-26	Screw
27	1	77-50141W-27	Cable
28	1	77-50141W-28	Brake/Shaft Assy
29	2	77-50141W-29	Tie Bar
30	1	77-50141W-30	Motor End *
31	1	77-50141W-31	Solenoid Assy *
32	1	77-50141W-32	Solenoid Bracket 1
33	1	77-50141W-33	Solenoid Bracket 2
34	2	77-50141W-34	Solenoid Bracket 3
35	2	77-50141W-35	Solenoid Bracket 4
36	5	77-50141W-36	Washer M6
37	5	77-50141W-37	Spring Washer M6
38	5	77-50141W-38	Screw M6 × 16
39	2	77-50141W-39	Washer M6
40	2	77-50141W-40	Spring Washer M6
41	2	77-50141W-41	Screw M6 × 12
42	2	77-50141W-42	Screw M5 × 16
43	2	77-50141W-43	Spring Washer M5
44	1	77-50141W-44	Mount Channel (Optional)
45	1	77-50141W-45	Roller Fairlead
46	4	77-50141W-46	Washer
47	4	77-50141W-47	Spring Washer
48	4	77-50141W-48	Screw
49	1	77-50141W-49	Safety Hook
50	1	77-50141W-50	Switch Assy
51	1	77-50141W-51	Hand Strap

* 24V PART NUMBER

77-51141W-30
77-51141W-31

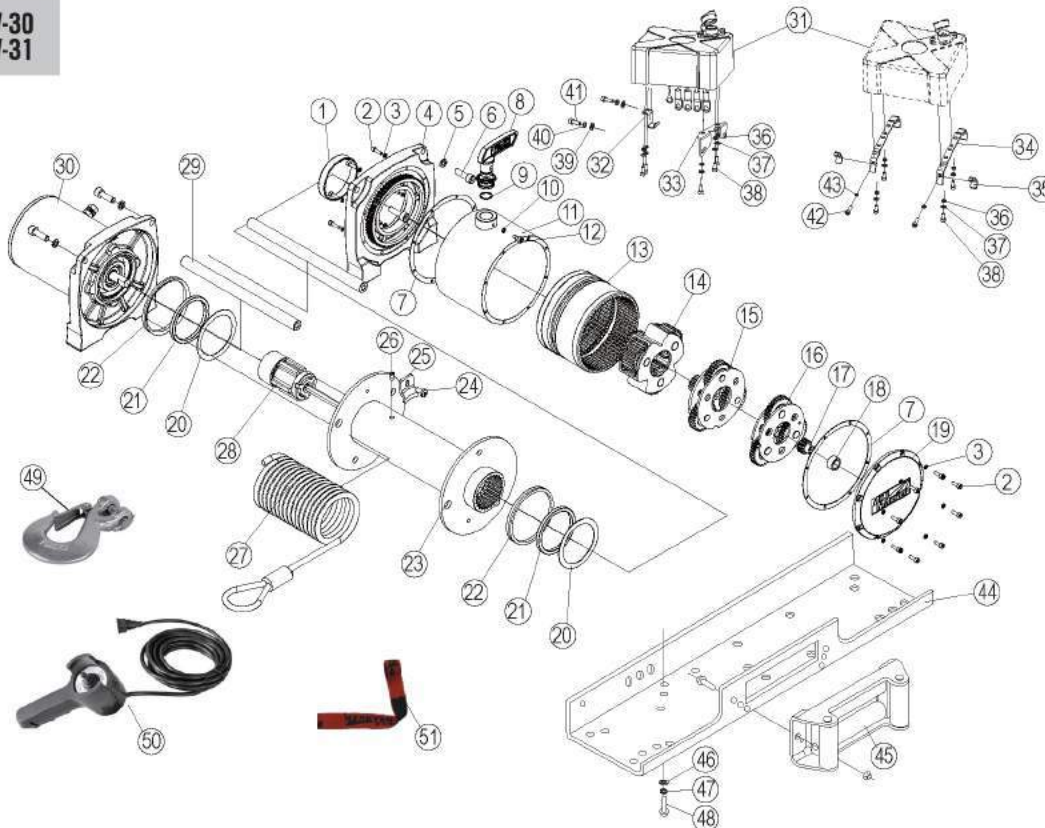

Parts Breakdown & Assembly - SEC8 Scout (ES)

Item	Quantity	Part Number	Description
1	1	77-50141W-01	Dry Bearing
2	16	77-50141W-02	Screw M4 × 12
3	16	77-50141W-03	Spring Washer M4
4	1	77-50141W-04	End Bearing
5	4	77-50141W-05	Spring Washer M8
6	4	77-50141W-06	Screw M8 × 25
7	2	77-50141W-07	Gasket
8	1	77-50141W-08	Clutch Handle
9	1	77-50141W-09	Seal
10	1	77-50141W-10	Spring Washer
11	1	77-50141W-11	Gear Ring
12	1	77-50141W-12	Retaining Screw
13	1	77-50141W-13	Gear Ring-input/intermediate
14	1	77-50141W-14	Gear Carrier Assy-output
15	1	77-50141W-15	Gear Carrier Assy-intermediate
16	1	77-50141W-16	Gear Carrier Assy-input
17	1	77-50141W-17	Gear-input sun
18	1	77-50141W-18	Gear Bushing
19	1	77-50141W-19	Gear Box Cover
20	2	77-50141W-20	Spacer
21	2	77-50141W-21	Ring
22	2	77-50141W-22	Seal Ring
23	1	77-50141W-23	Drum Assy
24	1	77-50141W-24	Screw
25	1	77-50141W-25	Cable Anchor

Item	Quantity	Part Number	Description
26	1	77-50141W-26	Screw
27	1	19-52132-96	Synthetic Rope
28	1	77-50141W-28	Brake/Shaft Assy
29	2	77-50141W-29	Tie Bar
30	1	77-50141W-30	Motor End *
31	1	77-50141W-31	Solenoid Assy *
32	1	77-50141W-32	Solenoid Bracket 1
33	1	77-50141W-33	Solenoid Bracket 2
34	2	77-50141W-34	Solenoid Bracket 3
35	2	77-50141W-35	Solenoid Bracket 4
36	5	77-50141W-36	Washer M6
37	5	77-50141W-37	Spring Washer M6
38	5	77-50141W-38	Screw M6 × 16
39	2	77-50141W-39	Washer M6
40	2	77-50141W-40	Spring Washer M6
41	2	77-50141W-41	Screw M6 × 12
42	2	77-50141W-42	Screw M5 × 16
43	2	77-50141W-43	Spring Washer M5
44	1	77-50141W-44	Mount Channel (Optional)
45	1	19-52002	Aluminum House Fairlead
46	4	77-50141W-46	Washer
47	4	77-50141W-47	Spring Washer
48	4	77-50141W-48	Screw
49	1	77-50141W-49	Safety Hook
50	1	77-50141W-50	Switch Assy
51	1	77-50141W-51	Hand Strap

* 24V PART NUMBER

77-51141W-30
77-51141W-31

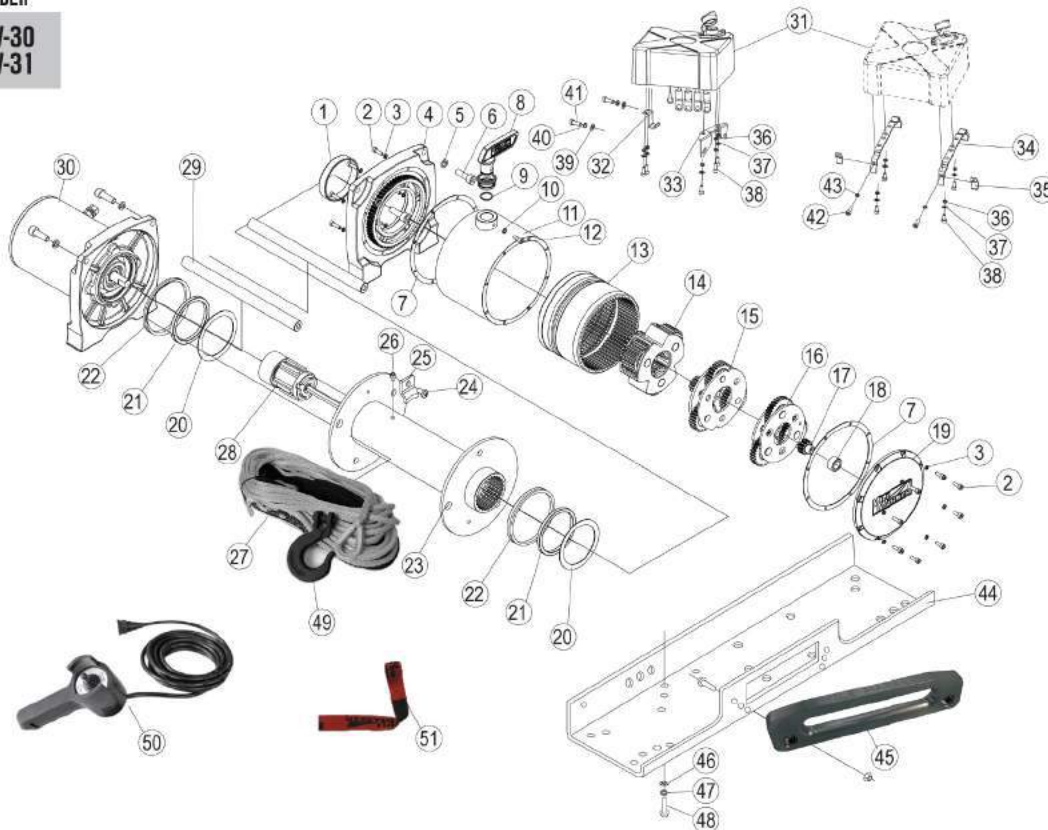

Parts Breakdown & Assembly - SEC95 (ES)

Item	Quantity	Part Number	Description
1	1	77-50141W-01	Dry Bearing
2	16	77-50141W-02	Screw M4 × 12
3	16	77-50141W-03	Spring Washer M4
4	1	77-50141W-04	End Bearing
5	4	77-50141W-05	Spring Washer M8
6	4	77-50141W-06	Screw M8 × 25
7	2	77-50141W-07	Gasket
8	1	77-50141W-08	Clutch Handle
9	1	77-50141W-09	Seal
10	1	77-50141W-10	Spring Washer
11	1	77-50141W-11	Gear Ring
12	1	77-50141W-12	Retaining Screw
13	1	77-50141W-13	Gear Ring-input/intermediate
14	1	77-50141W-14	Gear Carrier Assy-output
15	1	77-50141W-15	Gear Carrier Assy-intermediate
16	1	76-502568W-16	Gear Carrier Assy-input
17	1	76-502568W-17	Gear-input sun
18	1	77-50141W-18	Gear Bushing
19	1	77-50141W-19	Gear Box Cover
20	2	77-50141W-20	Spacer
21	2	77-50141W-21	Ring
22	2	77-50141W-22	Seal Ring
23	1	77-50141W-23	Drum Assy
24	1	77-50141W-24	Screw
25	1	77-50141W-25	Cable Anchor

Item	Quantity	Part Number	Description
26	1	77-50141W-26	Screw
27	1	76-502568W-27	Cable
28	1	77-50141W-28	Brake/Shaft Assy
29	2	77-50141W-29	Tie Bar
30	1	77-50141W-30	Motor End *
31	1	77-50141W-31	Solenoid Assy *
32	1	77-50141W-32	Solenoid Bracket 1
33	1	77-50141W-33	Solenoid Bracket 2
34	2	77-50141W-34	Solenoid Bracket 3
35	2	77-50141W-35	Solenoid Bracket 4
36	5	77-50141W-36	Washer M6
37	5	77-50141W-37	Spring Washer M6
38	5	77-50141W-38	Screw M6 × 16
39	2	77-50141W-39	Washer M6
40	2	77-50141W-40	Spring Washer M6
41	2	77-50141W-41	Screw M6 × 12
42	2	77-50141W-42	Screw M5 × 16
43	2	77-50141W-43	Spring Washer M5
44	1	77-50141W-44	Mount Channel (Optional)
45	1	77-50141W-45	Roller Fairlead
46	4	77-50141W-46	Washer
47	4	77-50141W-47	Spring Washer
48	4	77-50141W-48	Screw
49	1	76-502568W-49	Safety Hook
50	1	77-50141W-50	Switch Assy
51	1	77-50141W-51	Hand Strap

* 24V PART NUMBER

77-51141W-30
77-51141W-31

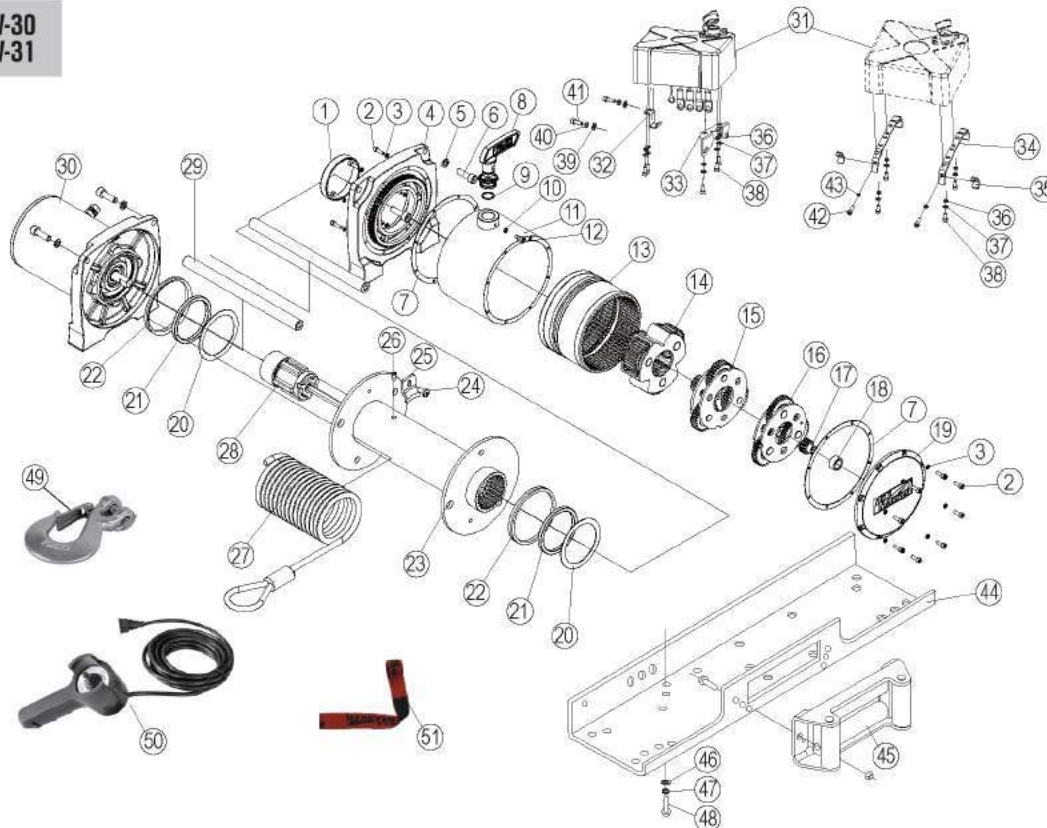

Parts Breakdown & Assembly - SEC12 (ES)

Item	Quantity	Part Number	Description
1	1	77-50141W-01	Dry Bearing
2	16	77-50141W-02	Screw M4 × 12
3	16	77-50141W-03	Spring Washer M4
4	1	77-50141W-04	End Bearing
5	4	77-50141W-05	Spring Washer M8
6	4	77-50141W-06	Screw M8 × 25
7	2	77-50141W-07	Gasket
8	1	77-50141W-08	Clutch Handle
9	1	77-50141W-09	Seal
10	1	77-50141W-10	Spring Washer
11	1	77-50141W-11	Gear Ring
12	1	77-50141W-12	Retaining Screw
13	1	77-50141W-13	Gear Ring-input/intermediate
14	1	77-50141W-14	Gear Carrier Assy-output
15	1	76-50251BW-15	Gear Carrier Assy-intermediate
16	1	76-50251BW-16	Gear Carrier Assy-input
17	1	76-50251BW-17	Gear-input sun
18	1	77-50141W-18	Gear Bushing
19	1	77-50141W-19	Gear Box Cover
20	2	77-50141W-20	Spacer
21	2	77-50141W-21	Ring
22	2	77-50141W-22	Seal Ring
23	1	77-50141W-23	Drum Assy
24	1	77-50141W-24	Screw
25	1	77-50141W-25	Cable Anchor

Item	Quantity	Part Number	Description
26	1	77-50141W-26	Screw
27	1	76-50251BW-27	Cable
28	1	77-50141W-28	Brake/Shaft Assy
29	2	77-50141W-29	Tie Bar
30	1	77-50141W-30	Motor End *
31	1	77-50141W-31	Solenoid Assy *
32	1	77-50141W-32	Solenoid Bracket 1
33	1	77-50141W-33	Solenoid Bracket 2
34	2	77-50141W-34	Solenoid Bracket 3
35	2	77-50141W-35	Solenoid Bracket 4
36	5	77-50141W-36	Washer M6
37	5	77-50141W-37	Spring Washer M6
38	5	77-50141W-38	Screw M6 × 16
39	2	77-50141W-39	Washer M6
40	2	77-50141W-40	Spring Washer M6
41	2	77-50141W-41	Screw M6 × 12
42	2	77-50141W-42	Screw M5 × 16
43	2	77-50141W-43	Spring Washer M5
44	1	77-50141W-44	Mount Channel (Optional)
45	1	77-50141W-45	Roller Fairlead
46	4	77-50141W-46	Washer
47	4	77-50141W-47	Spring Washer
48	4	77-50141W-48	Screw
49	1	76-50251BW-49	Safety Hook
50	1	77-50141W-50	Switch Assy
51	1	77-50141W-51	Hand Strap

* 24V PART NUMBER

77-51141W-30
77-51141W-31

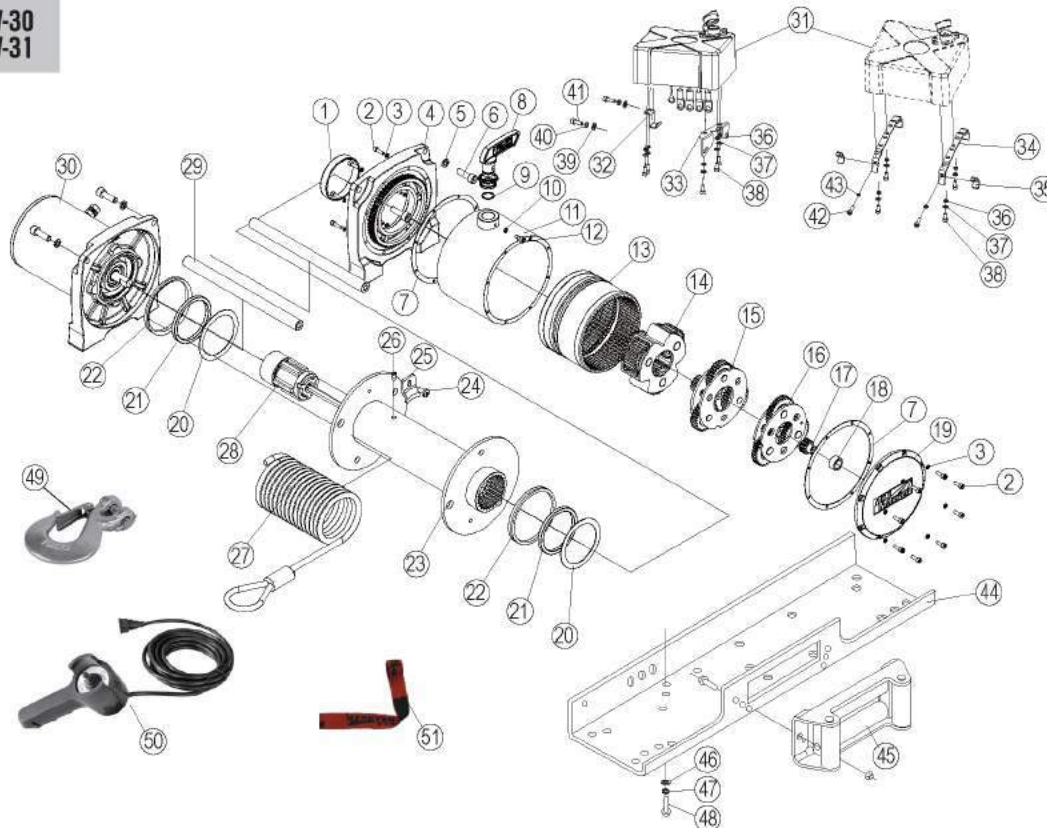

Parts Breakdown & Assembly - SEC15 (ES)

Item	Quantity	Part Number	Description
1	1	77-50141W-01	Dry Bearing
2	16	77-50141W-02	Screw M4 × 12
3	16	77-50141W-03	Spring Washer M4
4	1	77-50141W-04	End Bearing
5	4	77-50141W-05	Spring Washer M8
6	4	77-50141W-06	Screw M8 × 25
7	2	77-50141W-07	Gasket
8	1	77-50141W-08	Clutch Handle
9	1	77-50141W-09	Seal
10	1	77-50141W-10	Spring Washer
11	1	77-50141W-11	Gear Ring
12	1	77-50141W-12	Retaining Screw
13	1	77-50141W-13	Gear Ring-input/intermediate
14	1	77-50141W-14	Gear Carrier Assy-output
15	1	76-50260W-15	Gear Carrier Assy-intermediate
16	1	76-50260W-16	Gear Carrier Assy-input
17	1	76-50260W-17	Gear-input sun
18	1	77-50141W-18	Gear Bushing
19	1	77-50141W-19	Gear Box Cover
20	2	77-50141W-20	Spacer
21	2	77-50141W-21	Ring
22	2	77-50141W-22	Seal Ring
23	1	76-50260W-23	Drum Assy
24	1	77-50141W-24	Screw
25	1	77-50141W-25	Cable Anchor

Item	Quantity	Part Number	Description
26	1	77-50141W-26	Screw
27	1	76-50260W-27	Cable
28	1	76-50260W-28	Brake/Shaft Assy
29	2	77-50141W-29	Tie Bar
30	1	76-50260W-30	Motor End *
31	1	76-50260W-31	Solenoid Assy *
32	1	77-50141W-32	Solenoid Bracket 1
33	1	77-50141W-33	Solenoid Bracket 2
34	2	77-50141W-34	Solenoid Bracket 3
35	2	77-50141W-35	Solenoid Bracket 4
36	5	77-50141W-36	Washer M6
37	5	77-50141W-37	Spring Washer M6
38	5	77-50141W-38	Screw M6 × 16
39	2	77-50141W-39	Washer M6
40	2	77-50141W-40	Spring Washer M6
41	2	77-50141W-41	Screw M6 × 12
42	2	77-50141W-42	Screw M5 × 16
43	2	77-50141W-43	Spring Washer M5
44	1	77-50141W-44	Mount Channel (Optional)
45	1	77-50141W-45	Roller Farilead
46	4	77-50141W-46	Washer
47	4	77-50141W-47	Spring Washer
48	4	77-50141W-48	Screw
49	1	76-50260W-49	Safety Hook
50	1	77-50141W-50	Switch Assy
51	1	77-50141W-51	Hand Strap

* 24V PART NUMBER

76-51260W-30
76-51260W-31

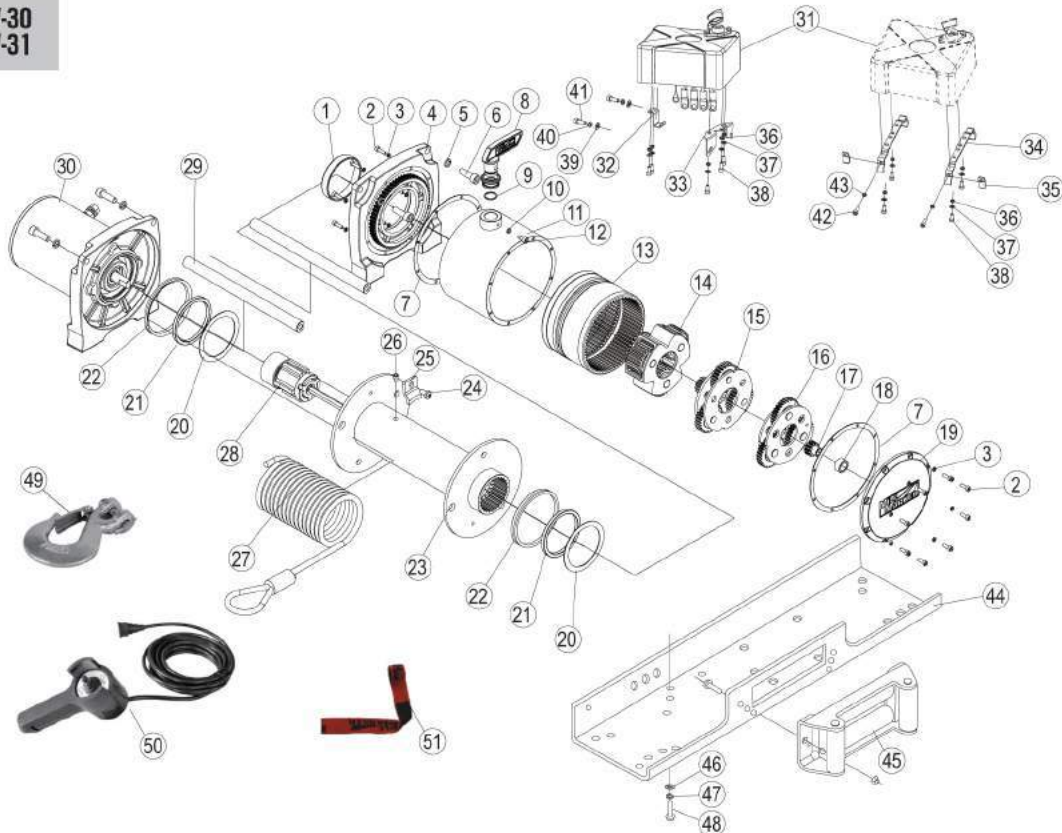

Parts Breakdown & Assembly - PE4500 (ES)

Item	Quantity	Part Number	Description
1	1	77-50141W-01	Dry Bearing
2	16	77-50141W-02	Screw M4 × 12
3	16	77-50141W-03	Spring Washer M4
4	1	77-50141W-04	End Bearing
5	4	77-50141W-05	Spring Washer M8
6	4	77-50141W-06	Screw M8 × 25
7	2	77-50141W-07	Gasket
8	1	77-50141W-08	Clutch Handle
9	1	77-50141W-09	Seal
10	1	77-50141W-10	Spring Washer
11	1	77-50141W-11	Gear Ring
12	1	77-50141W-12	Retaining Screw
13	1	77-50141W-13	Gear Ring-input/intermediate
14	1	77-50141W-14	Gear Carrier Assy-output
15	1	77-50141W-15	Gear Carrier Assy-intermediate
16	1	77-50141W-16	Gear Carrier Assy-input
17	1	77-50141W-17	Gear-input sun
18	1	77-50141W-18	Gear Bushing
19	1	77-50141W-19	Gear Box Cover
20	2	77-50141W-20	Spacer
21	2	77-50141W-21	Ring
22	2	77-50141W-22	Seal Ring
23	1	76-50115BW-23	Drum Assy
24	1	77-50141W-24	Screw
25	1	77-50141W-25	Cable Anchor
26	1	77-50141W-26	Screw
27	1	76-50115BW-27	Cable
28	1	76-50115BW-28	Brake/Shaft Assy

Item	Quantity	Part Number	Description
29	2	76-50115BW-29	Tie Bar
30	1	77-50141W-30	Motor End *
31	1	77-50141W-31	Solenoid Assy *
32	1	77-50141W-32	Solenoid Bracket 1
33	1	77-50141W-33	Solenoid Bracket 2
34	2	77-50141W-34	Solenoid Bracket 3
35	2	77-50141W-35	Solenoid Bracket 4
36	5	77-50141W-36	Washer M6
37	5	77-50141W-37	Spring Washer M6
38	5	77-50141W-38	Screw M6 × 16
39	2	77-50141W-39	Washer M6
40	2	77-50141W-40	Spring Washer M6
41	2	77-50141W-41	Screw M6 × 12
42	2	77-50141W-42	Screw M5 × 16
43	2	77-50141W-43	Spring Washer M5
44	2	76-50115BW-44	Risers
45	1	76-50115BW-45	Mount Channel
46	4	77-50141W-46	Screw
47	2	76-50115BW-47	Nut M10
48	2	76-50115BW-48	Nut M12
49	1	76-50115BW-49	Farilead Mount Plate
50	2	76-50115BW-50	Screw
51	1	WH4	Roller Farilead
52	2	76-50115BW-52	Screw
53	1	76-50115BW-53	Safety Hook
54	1	77-50141W-50	Switch Assy
55	1	19108	1" x 8ft ATV Straps (Optional)
56	1	77-50141W-51	Hand Strap

* 24V PART NUMBER

77-51141W-30
77-51141W-31

