

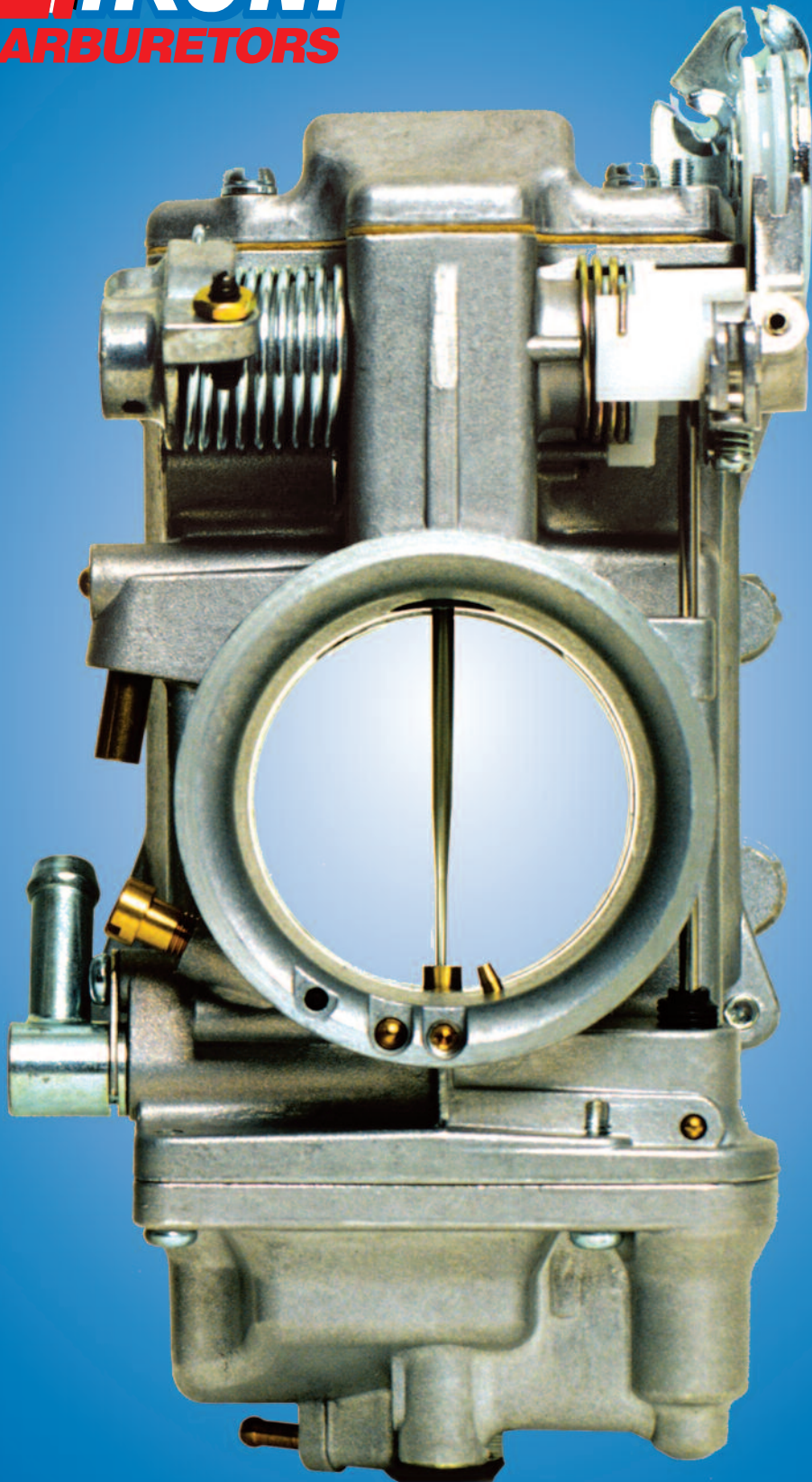

# Products Catalog



**PERFORMANCE STARTS HERE**

# HSR Series Carbs

## 42/45/48

## Smoothbore Carburetors

*Going fast has never been so easy!  
The number one performance carburetor for Harley-Davidsons and American Big Twins now slips onto any late model Harley-Davidson using the original throttle cables. Mikuni's Twin Cam, Big Twin and Sportster / Buell Easy Kits even use Harley's existing manifold, choke cable and air filter.*

*Keep a Harley's stock factory look and fit with better throttle response, improved acceleration, increased power and torque. Mikuni's smoothbore, flatslide throttle with roller bearings, and accelerator pump technology delivers peak performance from idle to Wide Open Throttle.*

*Available in 42, 45, and 48mm throttle bores for use with stock, mild, and highly modified engines.*

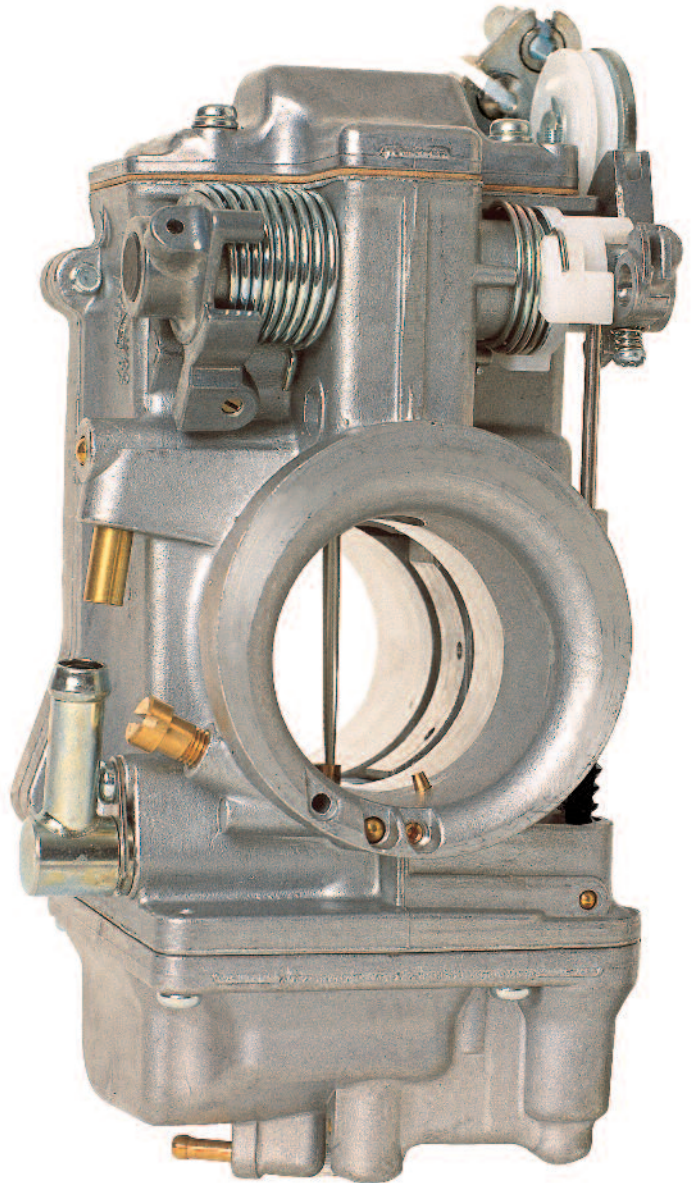

### **Bolt On a 25% Power and Torque Increase!**

Mikuni's Easy Kit dramatically improves the performance of Harley-Davidson's Twin Cam engine and delivers unmatched throttle response and acceleration! Used with a Screamin' Eagle Air Filter and an aftermarket exhaust system like the optional Screamin' Eagle Mufflers, the HSR42 Easy Kit adds 25% more horsepower to the output of Harley's Twin Cam motor. Maximum horsepower is increased from 57.8 to 72.2 hp, and maximum torque from 71.4 to 80.7 ft/lbs.

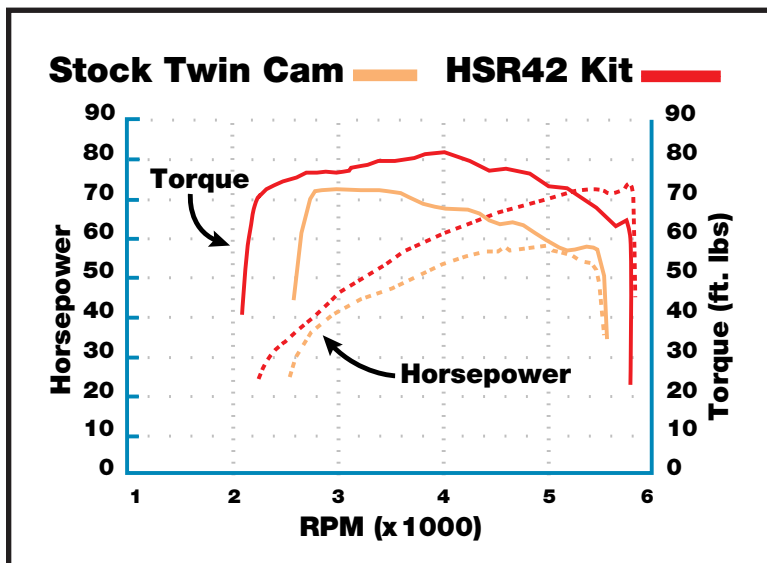

## 42/45/48 Smoothbore Kits

*Every Mikuni Carburetor Kit is an easy bolt-on application. Each HSR carburetor in the kit comes pre-jetted and ready to run!*

◀ **Easy Kits 42/45mm** Keep your stock look with our uniquely designed Easy Kit which uses your stock manifold and cables. Our special adapter retains your stock airbox or use the Screamin' Eagle performance air filter kit. California A.R.B. Legal Kits available for EVO Big Twin applications.



## Total Kits ▶ 42/45mm

Go for high flow! The complete Total Kit includes a special manifold, rubber flange and high flow air filter. Total Kits allow fitment of a HSR42 or 45mm carburetor to any Big Twin Evolution or Twin Cam model. Our high flow filter supports 100 horsepower with no loss from filter restriction. (Manifold clamps, seals are not included in the kit).

## Race Kits 48mm

A real racing carburetor for monster motors. The new HSR48 delivers the highest airflow with accurate fuel metering for more power and precise throttle control. An extended main jet and larger needle valve assembly assure maximum fuel flow to very powerful engines. Intended for use by experienced builders.

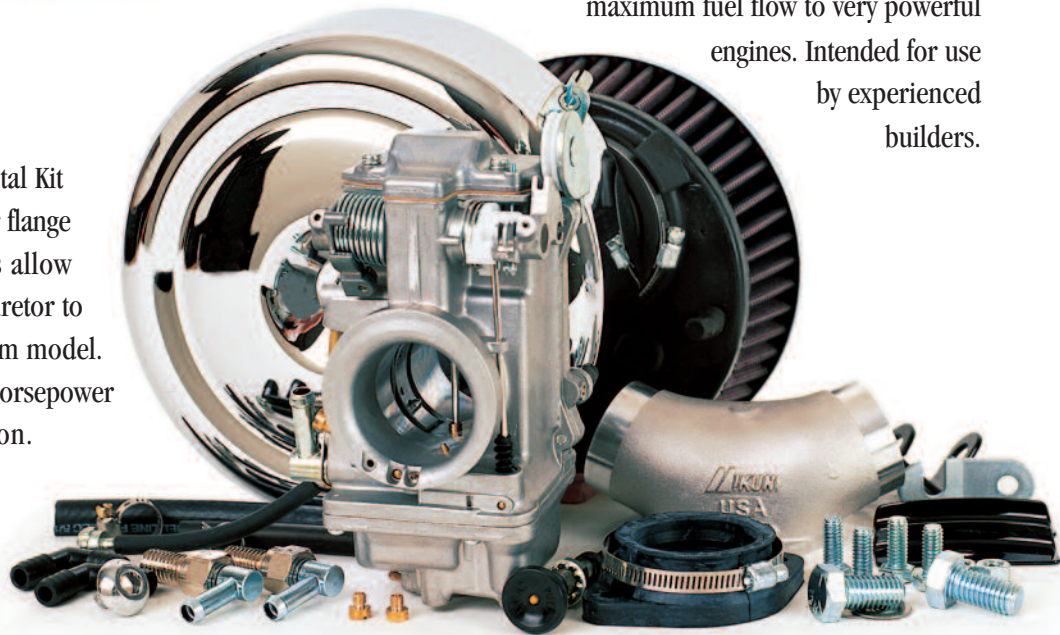

## ◀ Sportster / Buell Kits

Mikuni offers two different HSR42 Kits for Sportsters and Buells. One kit, just for Sportsters includes a special airbox backing plate as shown to work with the stock oval cover and a Screamin' Eagle high flow replacement filter. The other kit, without the backing plate, works on Buells and Sportsters with an aftermarket performance air filter assembly.

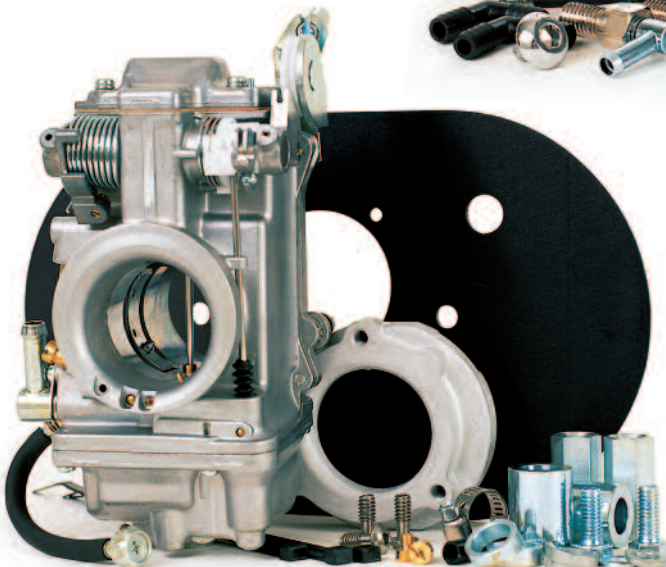

Carburetor kits not designated as C.A.R.B. exempt, are not legal for motor vehicles operated on public highways in the state of California or in other states and countries where similar anti-pollution laws may apply.

# HSR Applications

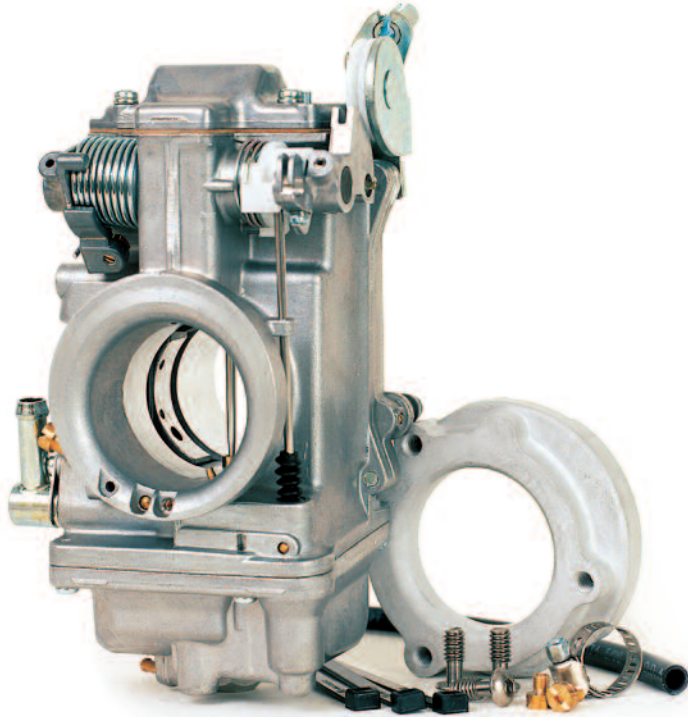

## Mikuni HSR Series Carburetor Kits

### HSR Carbs use stock Harley-Davidson throttle cables.

The latest 42/45/48mm smoothbore carburetors from Mikuni install quickly using the original stock throttle cables. The HSR flatslide carb delivers excellent throttle response and control. The smoothbore allows the engine to reach its full power potential, so you accelerate and pass with confidence. You'll get good gas mileage and many years of dependable, carefree performance. These kits cover more models with fewer part numbers. Kits include instructions and hardware for each application.

### Easy Kits for Sportsters, Big Twin and Twin Cam models

These kits are designed to work with your original Harley-Davidson intake manifold, choke cable, air cleaner and throttle cables. You can run other high performance air filters designed for the CV type carb by using the special adapter included in the kit.

- 42-7** 1990 to 1999 1340 Big Twin Evo with stock CV type manifold. Includes 42mm carb, airbox adapter and chrome cover.
- 42-18** 1999 to present Twin Cam, 1990 to '99 Big Twin Evo Includes 42mm carb, air box adapter, instructions. Twin Cam and Evo engines require the use of an aftermarket air cleaner. Will not work with stock air box.
- 42-10** 1994 to 2004 Sportster 1200. Includes 42mm carb, with special air box back plate. Requires the use of the stock oval cover and a Screamin' Eagle high flow replacement filter.
- 42-11** 1994 to 2006 Sportster 1200, Buell models. Must use with aftermarket performance air filter.
- 45-5** 1999 to present Twin Cam, 1990 to '99 Big Twin Evo Includes 45mm carb, air box adapter, instructions. Must use a H-D Screamin' Eagle Manifold Kit: Nos. 29634-00 (HTTC), 29635-99 (TC), or 29636-99 (Evo)

## Total Kits for Big Twin Evolutions & Twin Cam models

These kits are complete with everything needed for a total installation. Kits include an HSR 42mm or 45mm carburetor, new performance manifold, rubber flange, high flow air filter, chrome cover, chrome breather kit and mounting hardware. *Stock throttle cables from 1990 and later models can be used. Note: 1984 to 1989 Evo models will need new cables from a similar 1990 to 1995 model.*

- 42-8** **HSR42 Kits**  
1984 to 1999 1340 Big Twin Evo. Includes breather kit #KHS-020 for 1993 and later models. Note: 1984 to 1989 models require cables from 1990 to 1995 model bikes.
- 42-19** **HSR42 Kits**  
1999 to present Twin Cam 88/95. Includes new breather kit #KHS-030 for Twin Cams. Note: Use your stock throttle cables.
- 45-2** **HSR45 Kits**  
1984 to 1999 1340 Big Twin Evo. Includes a 45 mm big bore carburetor, breather kit #KHS-020 and a 45mm flange.
- 45-3** **HSR45 Kits**  
1984 to 1999 1340 Big Twin Evo. Same as kit above without intake manifold.
- 45-4** **HSR45 Kits**  
1999 to present Twin Cam 88/95. Includes 45mm carb, breather kit #KHS-030, new manifold with MAPS location and 45mm flange.

## Big Twin Evo CA Legal Kits

These kits may be used in California when all stock original components are unchanged. Kits are exempt from emission laws when installed according to instructions.

- 42-6** 1990 to 1998 1340 Big Twin Evolution models sold in California. Includes 42mm C.A.R.B. carb, airbox adapter, A/C cover and instructions. C.A.R.B. exemption No. D-389-4.



## Race Kit 48mm for Big Motors

Designed for the serious race engine builder and extreme street motor enthusiast looking for more power. Recommended for 120ci engines or bigger with high flow heads and cams. Kits include a 48mm smoothbore carb, rubber mounting flange (78mm bolt hole centers), choke cable, four main jets. Builder supplies manifold and appropriate air filter or velocity stack. Uses stock Harley CV type cables.

- 48-2** **HSR48 Race Kit, Standard**  
Standard cast alloy body, cadmium fittings
- 48-2P** **HSR48 Race Kit, Polished**  
Hand polished cast alloy body, chrome fittings

# Parts

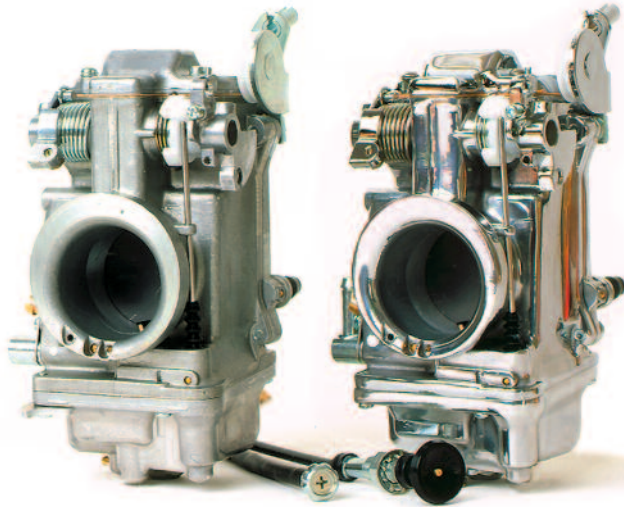

## Individual HSR42/45 Carburetors

For the performance engine builder needing the carburetor only for specific custom applications. Available in standard aluminum finish or the polished version. (Note: Choke cable is included, except on TM42-6 which will use stock choke cable from CV type carb).

- TM42-6** HSR 42mm Carburetor, Standard finish
- TM42-6PK** HSR 42mm Carburetor, Polished version
- TM45-2K** HSR 45mm Carburetor, Standard finish
- TM45-2PK** HSR 45mm Carburetor, Polished version

## HSR Accessories

### Crankcase Head-Breather Kits

For the installation of HSR Carburetor Kits using the Mikuni K&N high flow filter on Big Twins and Twin Cams.

- KHS-020** To mount HSR42/45 carb and filter to Evo Big Twins, includes the new chrome banjos, vent bolts and brackets.
- KHS-030** To mount HSR42/45 carb and filter to Twin Cam engine, includes the new chrome banjos, vent bolts and brackets.

### Jet Assortment Kit for HSR

Jet Assortment Kits contain 44 pieces in a special jet box. Included are 2 ea. of a wide range of Main Jets, Pilot Jets, Needles, A/P Nozzles, Needle Clips, Needle Washers.



- KHS-025** HSR42 Jet Kit with box, 44 piece assortment.
- KHS-045** HSR45 Jet Kit with box, 44 piece assortment.
- KHS-048** HSR48 Jet Kit with box, 44 piece assortment.

### HSR42/45/48 Carb Rebuild Kits

All the necessary parts and gaskets to freshen up an HSR carb. Includes needle valve assembly, O-rings, gaskets, screws.

- KHS-016** Rebuild Kit for HSR42/45 Carb with 4.2 needle valve & exploded view instructions.
- KHS-031** Rebuild Kit for HSR48 Carb with 4.5 needle valve & exploded view instructions.

## Optional and Replacement Parts

- 990-605-065** Short Idle Screw Adjuster (optional). Uses standard spring.
- TM42/32** Long Idle Cable Adjuster (standard). Spring not included.
- 990-662-002** Choke Cable, enricher.
- HS42/001K** Air Box Adapter Kit, std. finish
- HS42/001-CHR-K** Air Box Adapter Kit, chrome finish
- HS42/002** Adapter Screws, use three per adapter.
- HS42/003** O-Ring Seal for airbox adapter.
- HS42/018-42K** Rubber Flange Adapter, early 42mm black w/stainless steel clamp.
- HS42/018-45K** Rubber Flange Adapter, early 45mm black w/stainless steel clamp.
- HS42/061-45** Intake Manifold for HSR42/45 mm, Evo style without hole.
- HS42/061-45TC** Intake Manifold for HSR42/45 mm, Twin Cam style with MAPS hole.
- HS42/062-42K** Rubber Flange Adapter, 42mm black w/stainless steel clamp.
- HS42/062-45K** Rubber Flange Adapter, 45mm black w/stainless steel clamp.
- HS42/062-48K** Rubber Flange Adapter, 48mm black w/stainless steel clamp.
- HS42/012** Air Filter, K&N 2.5 inch, standard in kits, washable
- HS42/012-300** Air Filter, K&N 3.0 inch, high performance, washable
- HS42/059** Air Cleaner Cover, chrome w/cutouts
- HS42/060** Air Cleaner Cover, chrome wo/cutouts
- KHS-028** Chrome Carb Top 42/45 w/Mikuni
- KHS-029** Chrome Carb Top 42/45 w/Mikuni
- KHS-032** Chrome Carb Top 48 w/Mikuni logo

## Jetting Parts

High speed (main), low speed (pilot) jets, jet needles and accelerator pump nozzle for the HSR42/45/48 carburetors.

- VM28/486**-(size) Pilot Jets, sizes 15 to 50
- N100.604**-(size) Main Jets, sizes 140 to 240
- J8-8DDY01**-(size) HSR42 Jet Needles, size 95, 96, 97 and 98, standard in HSR42 is 97.
- J8-8CFY02**-(size) HSR45 Jet Needles same as above
- J8-8CFY15**-(size) HSR48 Jet Needles same as above
- TM42/11**-(size) Accelerator Pump Nozzle, size 50, 60, and 70, standard is 70.
- N124.063** Accelerator Pump O-Ring

## Throttle Cables - early HSR 42/45

HSR42/45 Carb Kits from 1994 to 1999 required Mikuni throttle cables. HSR42 carbs made after May 1999, and HSR45 made after March 2000 use stock Harley-Davidson cables.

- HS42/028-A** Open (Throttle) Cable, 1970 to 1995, 38 inch screw-in type.
- HS42/029-A** Close (Idle) Cable, 1970 to 1995, 38 inch screw-in type.
- KHS/039** Open (Throttle) Cable, 1970 to 1995, 47 inch screw-in type.
- KHS/040** Close (Idle) Cable, 1970 to 1995, 47 inch screw-in type.
- KHS/043** Open (Throttle) Cable, 1996 to present, 38 inch push-in type.
- KHS/044** Close (Idle) Cable, 1996 to present, 38 inch push-in type.
- KHS/041** Open (Throttle) Cable, 1996 to present, 47 inch push-in type.
- KHS/042** Close (Idle) Cable, 1996 to present, 47 inch push-in type.

# HSR Replacement

## HSR42/45/48 Parts List

#	PART NO.	DESCRIPTION
1.	C5=0410-B	Screw, Top Cover (HSR42/45)
1a.	KHS-028/05	Screw, Top Cover (HSR48)
2.	CW2=0414-B	Screw, Top Cover (HSR42/45/48)
3.	776-39005	Top Cover (42/45)
3a.	HS42/081	Top Cover (HSR48)
4.	<b>TM42/04</b>	<b>Gasket, Top Cover</b>
5.	<b>BS32/126</b>	<b>E-Ring, Jet Needle</b>
6.	<b>826-03002</b>	<b>Washer, Jet Needle</b>
7.	J8-8DDY01-97	Jet Needle (42)
7a.	J8-8CFY02-97	Jet Needle (45)
7b.	J8-8CFY15-97	Jet Needle (48)
8.	TM42/03	Lever, T.V. (42/45)
8a.	TM42/08-1A	Lever, T.V. (HSR48)
9.	B40I/56	E-Ring, Link Lever
10.	B40I/10	Packing, Link Lever
11.	834-23041	Pin, Link Lever
12.	TM42/08-3.0	Throttle Valve (Slide)
13.	739-13002	Screw, Needle Retainer
14.	TM42/16	Clip, Needle Retainer
15.	TM42/13	Sealing Ring, T.V. (42/45)
15a.	TM48/04	Sealing Ring, T.V. (48)
16.	<b>TM42/10</b>	<b>Seal, Throttle Valve</b>
17.	925-98006	Pulley, Cable Bracket
18.	53974	E-Ring, Cable Bracket
19.	TM42/51	Bracket Ass'y, Cable
19a.	TM42/53	Bracket Ass'y, Sportster
20.	B3=0520-B	Bolt, Bracket
21.	VM28/204	Spacer, Bracket
22.	TM42/38	Plate, Lock Tab
23.	C2=0514-B	Screw
24.	640-12001	Starter Nut, Choke
25.	VM14/241	Spring, Starter Plunger
26.	N189.192	Starter Plunger
27.	<del>TM42/06</del>	Body (HSR42/45)
27a.	<del>TM48/02</del>	Body (HSR48)
28.	616-94029	Seal, Spigot Body
29.	<del>925-19011</del>	Ring (Steel)
30.	TM42/43	Lever, A/P
31.	N138.019	Pin, Throttle Lever
32.	TM42/48	Lever, Throttle
33.	M12F/46-BB	Spring, A/P
34.	MC-0316-B	Screw, A/P
35.	TM42/47	Spring, A/P
36.	<del>TM42SS1/01-0</del>	Mixing Body (42/45)
36a.	<del>TM48SS1/01-</del>	Mixing Body (48)
37.	B36/95	Packing, Shaft (Plastic)
38.	TM42/36	Adjusting Screw, A/P
39.	B30/205	O-Ring, A/P Screw
40.	TM40/89	Bolt
40a.	TM42/17	Plate, Lock Tab for Shaft
41.	BN38/43	Pin, Return Lever
42.	TM42/46	Lever, Return
43.	B30/1069	Adjusting Screw, Throttle
44.	N3=04	Nut, Throttle Stop
45.	TM42/19	Spring, Throttle Return
46.	700-15012	Shaft, Throttle
47.	<del>TM42/15</del>	Plate, Fuel Joint Retainer
48.	C2=0410	Screw, Fuel Joint
49.	604-26014	Screw, Pilot Air
49a.	VM20/584	Optional Short Screw, Pilot Air
50.	N133.206	Spring, Pilot Air
51.	VM12/205	Washer, Pilot Air

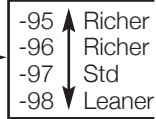

52.	N133.037
53.	TM40/27
54.	<b>KV/10</b>
55.	B30/398
56.	VM22/138
57.	730-09018
58.	925-15001
59.	TM42/32
59a.	990-605-065
60.	BS30/97-00
61.	784-430000-Y-6
62.	TM42/11-70
63.	<b>N124.063</b>
64.	VM28/486-25
65.	TM42/12
65a.	TM42/12-1A
66.	N100.604-160
67.	<b>616-33003</b>
68.	<b>VM13/216</b>
69.	<b>786-27001-4.2</b>
69a.	<b>786-27002-1A-4.5</b>
70.	859-32027
71.	BV26/22
72.	C2=0410
73.	<b>616-94028</b>
74.	TM42/05
75.	<b>N122.028</b>
76.	<b>VM28/254</b>
77.	TM32/41
77a.	TM32/41-1D
78.	<b>C2=0412-B</b>
79.	TM36/44-1A
80.	<b>TM36/64</b>
81.	TM36/60
82.	VM14SC13/89
83.	N198.063
84.	990-662-002
85.	TM29/31
86.	BVK28/128

O-Ring, Pilot Air
Fuel Joint
<b>O-Ring, Fuel Joint</b>
Packing, Idle Adjuster
Washer, Idle Adjuster
Spring, Idle Adjuster
Ring, Idle Adjuster
Idle Adjuster (Long)
Idle Adjuster (Short)
Air Jet (Blank)
Needle Jet (723)
Nozzle, Accel, Pump →
<b>O-Ring, A/P</b>
Pilot Jet (Sportster - 20)
Extender, Main Jet (42/45)
Extender, Main Jet (48)
Main Jet (45-175, 48-190)
<b>O-Ring N.V.</b>
<b>Screw, N.V. Retainer</b>
<b>Needle Valve Assbly (42/45)</b>
<b>Needle Valve Assbly (48)</b>
Float Ass'y
Pin, Float
Screw, Float Pin
<b>Packing, Float Bowl</b>
Float, Chamber Body
<b>Hose, Overflow</b>
<b>O-Ring, Drain Plug</b>
Drain plug (42/45)
Drain plug (48)
<b>Screw, Fit Bowl, short</b>
Rod, A/P
<b>Boot, A/P Rod</b>
Plunger, A/P
Spring, A/P
Rubber Cap, Purge Port
Choke Cable
Pull Choke Assembly
Clip, Rubber Cap

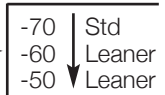

### Alternate Parts

#### Jet Needles:

HSR42	HSR45	HSR48	
J8-8DDY01-95	J8-8CFY02-95	J8-8CFY15-95	Richer
J8-8DDY01-96	J8-8CFY02-96	J8-8CFY15-96	Richer
J8-8DDY01-97	J8-8CFY02-97	J8-8CFY15-97	Std
J8-8DDY01-98	J8-8CFY02-98	J8-8CFY15-98	Leaner

#### Accelerator Pump Nozzles:

TM42/11-70	Std
TM42/11-60	Leaner
TM42/11-50	Leaner

#### Needle Valve Assemblies:

786-27002-1A-4.5	Std (HSR48)
786-27001-4.2	Std (HSR42/45)
786-27001-3.5	Smaller
786-27001-2.3	Pressure feed only

#### Rebuild Kit:

HSR42/45:	KHS-016
HSR48:	KHS-031

#### NOTES:

1. ~~---~~ Lined through Part Numbers are not available.
2. Parts in **Bold** are included in Rebuild Kits.

## Exploded View HSR42/45/48

84 CHOKE CABLE ASSEMBLY  
990-662-002

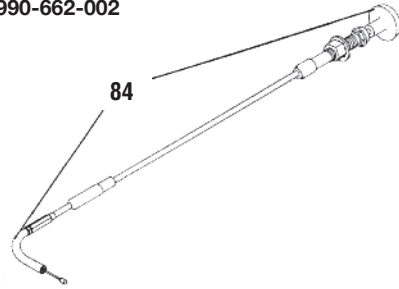

85 Choke Pull Assembly  
TM29/31



**KHS-034 Main Jet Extender Kit**  
Includes a Threaded Extension Tube for lowering the Main Jet into a deeper Long Float Bowl Drain Plug (TM32/41-1C) to reduce fuel starvation under full throttle and high performance applications. See listing Page 9

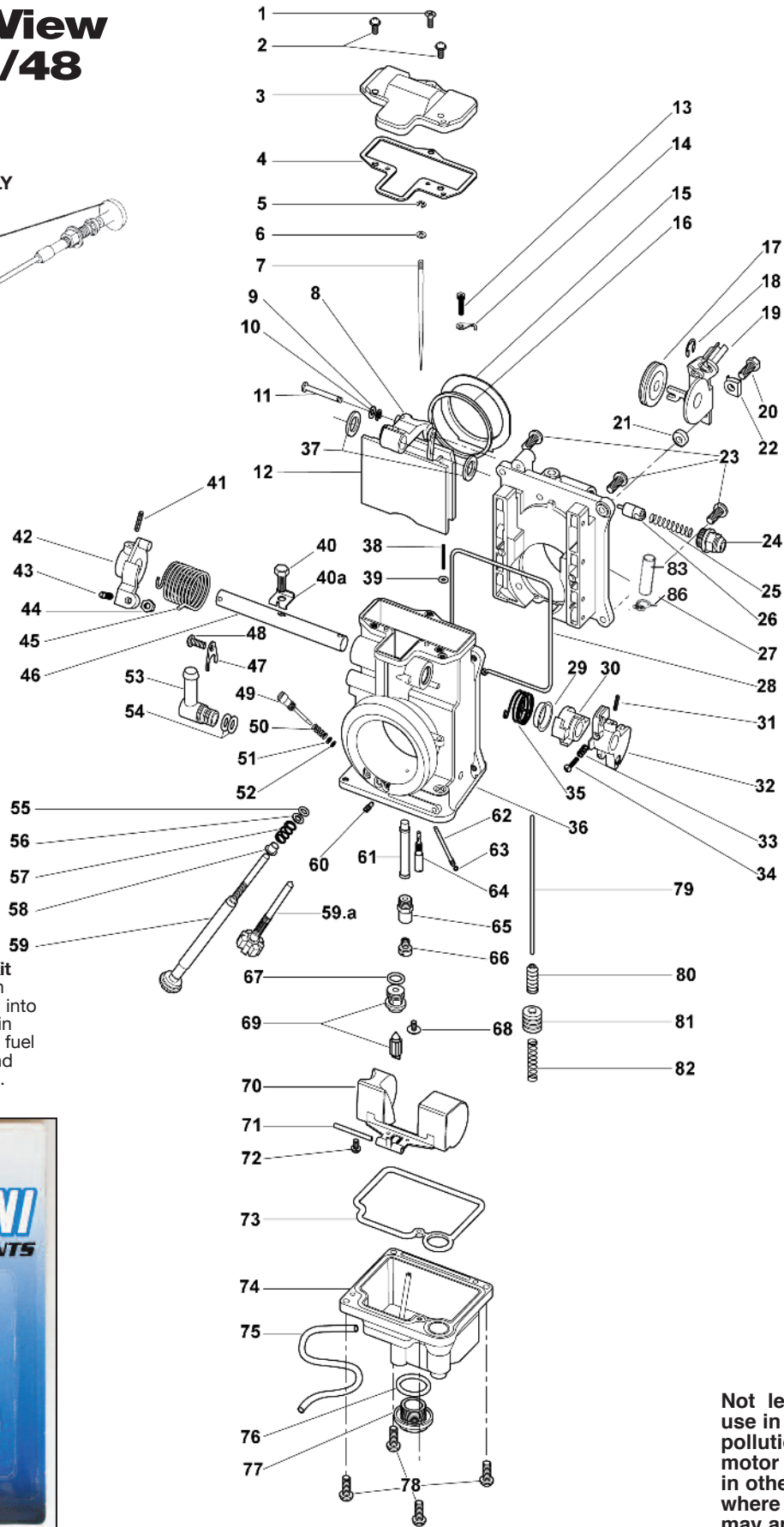

Not legal for sale or use in California on pollution controlled motor vehicles, or in other states where similar laws may apply.

# HS Replacement

TM36 Jetting

## HS40 Carburetor Exploded View same as TM40-6 and TM36-68

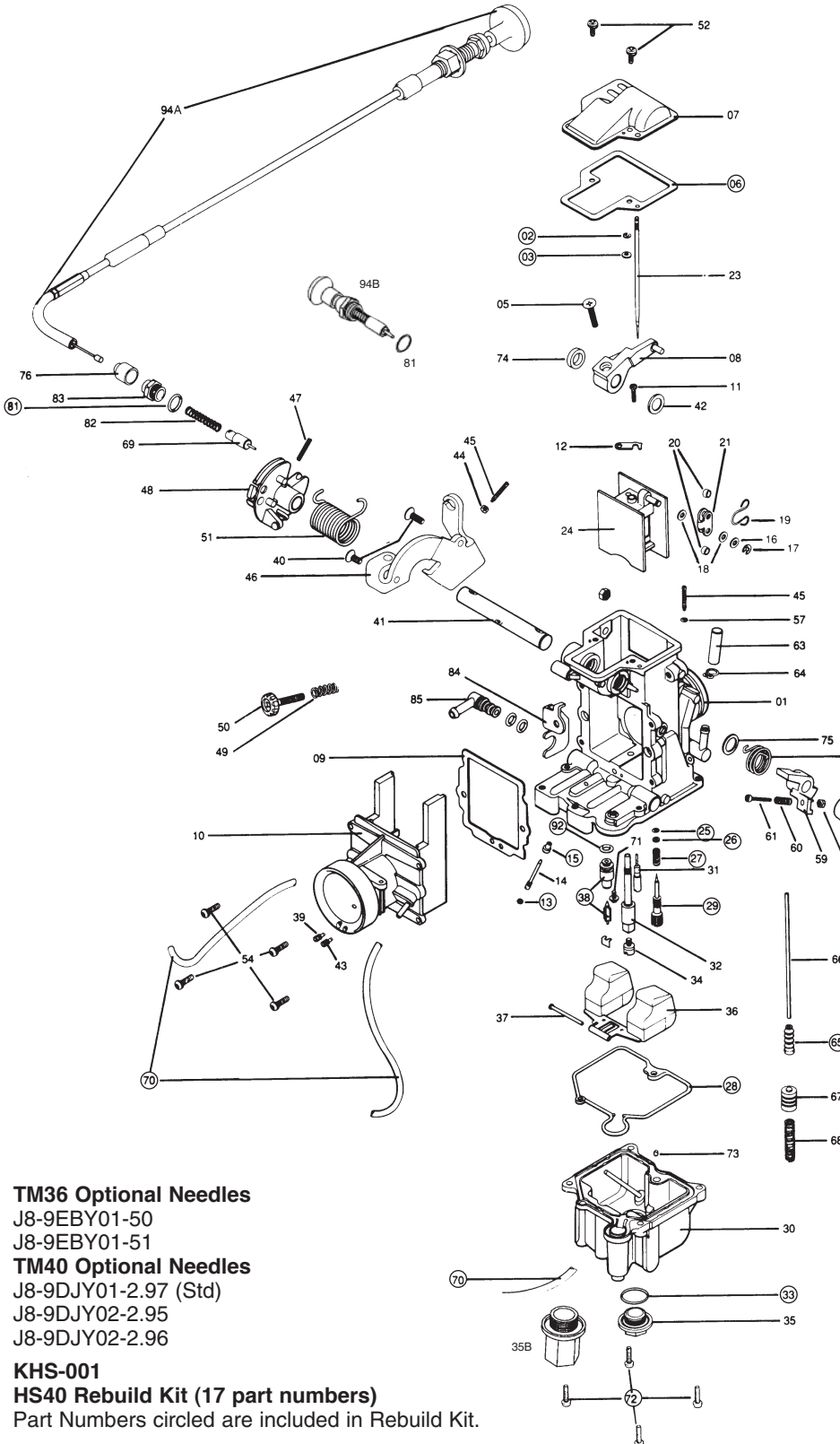

NO.	DESCRIPTION	PART NO.	
01	Mixing body	TM4055/04	
02	E. Ring	BS32/126	
03	Washer, Needle clip	826-03002	
04	Allen Screw	739-13001	
05	Screw, synch lock	C5 = 0514	
06	Gasket, top cover	TM 36/39	
07	Top Cover	TM 36/59	
08	Lever Assy	TM 36/57	
09	Gasket, funnel	TM 36/42a	
10	Funnel	TM 40/03	
11	Screw, T.V. Plate	C2 = 0340	
12	Plate, T.V. Lever	TM 36/42	
13	O'Ring, A/P Nozzle	N124.063	
14	Pump, Nozzle	TM 36/43	
15	Plug, A/P Nozzle	TM 29/14	
16	Washer, T. V. Lever	M 40/56	
17	E. Ring, A/P Nozzle	BSW 28/70	
18	Packing, T.V. Lever	D 401/40	
19	Clip T.V. Lever	TM 27/05 A	
20	Ring, T.V. Lever	TM 29/65	
21	Plate, T.V. Lever	TM 27/04	
22	Connector Plate, T.V.	TM 36/54	
23	Jet Needle	J8-9DJY01	9DZH6-50
24	Throttle Valve	N/A	
25	O'Ring, Fuel Screw	N 133.037	
26	Washer, Fuel Screw	VM 12/33	
27	Spring, Fuel Screw	N 133.206	
28	O'Ring Float Bowl	616-94021	
29	Screw, Pilot Fuel	604-26003	
30	Float Chamber Body	TM 40/12	
31	Pilot Jet	VM 28/486-17.5	-12.5
32	Needle Jet	784-13002-Y6	-P-8
33	O'Ring Drain Plug	VM 28/254	
34	Main Jet	N 100.604-165	-130
35	Drain Plug	TM 32/41	
35B	Drain Plug, Long (36)	TM32/41-1C	
36	Float Assy	859-32011	
37	Pin, Float	VM 30/160	
38	Needle Valve Assy (36)	786-36011-3.3	
38A	Needle Valve Assy (40)	990-786-044	
39	Main Air Jet (Plugged)	BS30/97	
40	Screw, Crank Bracket	C5 = 0512-B	
41	Shaft, Throttle	700-15004	
42	Packing		
43	Pilot Air Jet	BS 30/97-1.1	-1.0
44	Hexagon Nut	N2 = 03 B	
45	Adjust Screw	TM 36/48	
46	Bracket, Bell Crank	TM 40/14	
47	Pin, Throttle Bell Crank	N 138.019	
48	Lever Assy, Bell Crank	TM 40/23	
49	Spring, Idle Adjust	N150.025	
50	Adjuster, Idle	TM 40/91	
51	Spring, Throttle Return	TM 40/25	
52	Screw, Top Cover	CW2 = 0408	
54	Screw, Air Funnel	VM 28/133	
55	Pin, A/P Locate	BN 38/43	
56	Lever, A/Pump	TM 36/18	
57	O'Ring	B 30/205	
58	Spring, A/Pump	TM 40/33	
59	Lever, A/Pump	TM 36/17	
60	Spring, A/P Adj	M12F/46a	
61	Screw, A/P Adj	MC-0316	
62	Hexagon nut, A/P Adj	N3 = 03-B	
63	CAP, Vacuum Fitting	N148.013	
64	Spring Clip, Vac Fit	BVK28/128	
65	CAP, A/P Rubber	TM 36/64	
66	Rod, A/Pump	TM 36/44	
67	Plunger	TM 36/60	
68	Spring, A/Pump	VM 14SC13/89	
69	Plunger, Starter	VM 38/148	
70	Hose	888-23026	
71	Screw, N.V. Holder	VM 13/216	
72	Screw, Float Bowl	C2 = 0412-B	
73	Starter Jet	VM 17/1002-45	
74	Packing, Shaft	VM 28/174	
75	Ring, A/P Spring	E 204040	
76	Cap, Starter Cable	VM 12/43	
81	O'Ring, Starter	N 138.198	
82	Spring Starter	VM 16/42	
83	Guide Holder	640-12001	
84	Plate, Fuel Inlet	TM 40/26	
85	Inlet, Fuel	TM 40/27	
92	O'Ring, needle valve	KV/10	
94	Choke Cable Assy	990-662-001	
94B	Chokeknob, Short	TM40/07	

### TM36 Optional Needles

J8-9EBY01-50

J8-9EBY01-51

### TM40 Optional Needles

J8-9DJY01-2.97 (Std)

J8-9DJY02-2.95

J8-9DJY02-2.96

### KHS-001

### HS40 Rebuild Kit (17 part numbers)

Part Numbers circled are included in Rebuild Kit.

PART NUMBER (999-999) = NO AVAILABLE STOCK



## Mikuni HSR Carburetor Accessories

The following Mikuni American accessories are available for use with Mikuni HS-40, HSR42 / 45 / 48 Carburetor Kits. These parts are available through your dealer.

<b>ACCESSORIES</b>	<b>Part Nos. HS40</b>	<b>HSR42/45/48</b>
<b>Carburetor Rebuild Kit</b> (Includes gaskets & needle valve)	<b>KHS-001</b>	<b>KHS-016, KHS-031 (48)</b>
<b>HSR Easy Tool Kit</b> (Includes Wrench, T-Handle, 2 Bits)		<b>KHS-033</b>
<b>K &amp; N/ Mikuni Air Filter</b>	<b>RS36/25-200</b>	<b>HS42/012 (2.5")</b>
<b>K &amp; N/ Mikuni Air Filter - Extra Wide / High Flow</b>		<b>HS 42/012-300 (3.0")</b>
<b>Chrome Air Cleaner Cover</b> (OEM / cut-outs)		<b>HS42/059</b>
<b>Chrome Air Cleaner Cover</b> (Aftermarket / No cut-outs)	<b>RS36/24-200-CHR</b>	<b>HS42/060</b>
<b>EVO Head Breather Kit</b> (1991 to present Sportsters / 1993 to present 1340's)		<b>KHS-020</b>
<b>Twin Cam Head Breather Kit</b>		<b>KHS-030</b>
<b>EVO 1340 Manifold</b>		<b>HS42/061-45</b>
<b>Twin Cam Manifold</b>		<b>HS42/061-45TC</b>
<b>Rubber Flange, Early Style</b> (with clamp)	<b>KHS-004</b>	<b>HS42/018-42K</b> <b>HS42/018-45K</b>
<b>Rubber Flange, New Style</b> (with clamp)	<b>KHS-004</b>	<b>HS42/062-42K</b> <b>HS42/062-45K</b> <b>HS42/062-48K</b>
<b>Choke Cable Assembly</b> <b>Choke Pull Assembly</b>	<b>990-662-001</b>	<b>990-662-002</b> <b>TM29/31</b>
<b>Optional Short Idle Screw</b>		<b>990-605-065</b>
<b>HSR Main Jet Extension Kit</b> for high performance applications (shown on page 7)		<b>KHS-034</b>

## THROTTLE CABLES for EARLY HSR42/45

## Part No. HSR42/45

<b>Standard Length</b> (38") Open	1995 and Earlier	<b>HS42/028-A</b>
<b>Standard Length</b> (38") Close	"	<b>HS42/029-A</b>
<b>Longer Length</b> (47") Open	"	<b>KHS/039</b>
<b>Longer Length</b> (47") Close	"	<b>KHS/040</b>
<b>Longer Length</b> (47") Open	1996 and Later	<b>KHS/041</b>
<b>Longer Length</b> (47") Close	"	<b>KHS/042</b>
<b>Standard Length</b> (38") Open	"	<b>KHS/043</b>
<b>Standard Length</b> (38") Close	"	<b>KHS/044</b>

Cable Notes: Open = Throttle / Pull Cable, Close = Idle / Push Cable

### HSR Easy Tool Kit KHS-033 Includes:

Wrench 17mm x 11/16" loosen/tighten choke nut, drain plug. Main Jet T-Wrench, Phillips/Flat Head Screwdriver, Ball End 2.5 Allen for jet needle retainer.



**Early Style HSR42/45**  
Manufactured before year 2000 with throttle linkage on left. Uses Mikuni cables.

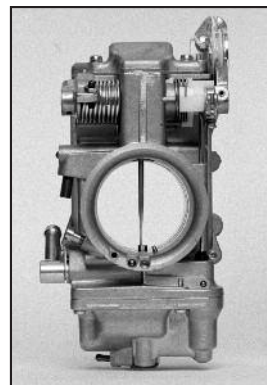
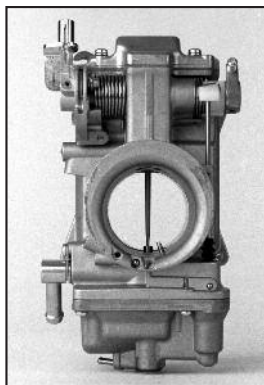

### HSR Carburetor Designs

**Late Style HSR42/45/48**  
Manufactured from year 2000 with throttle linkage on right. Uses stock OEM Harley-Davidson cables.

# RS Series Carbs

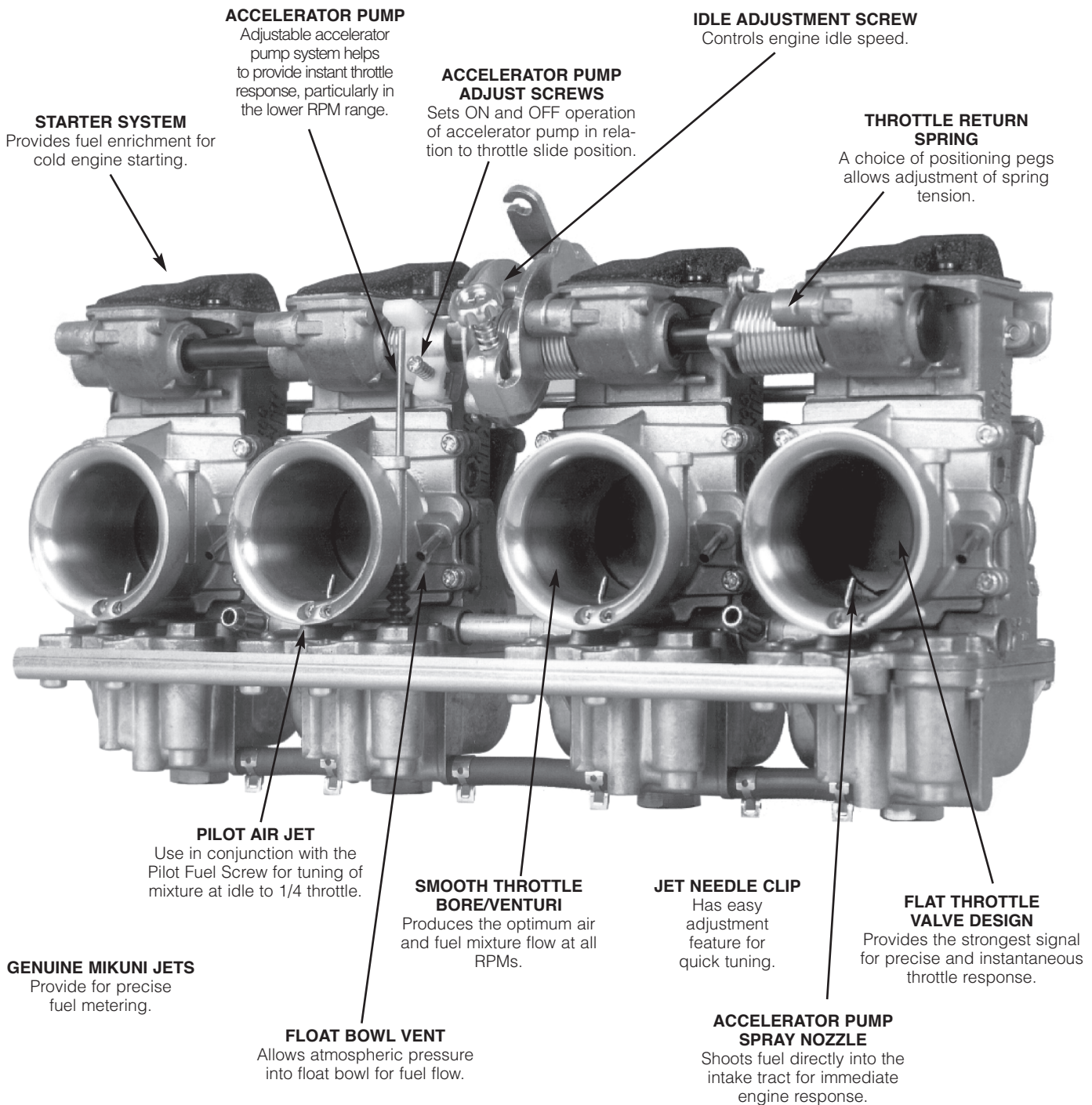

**STARTER SYSTEM**  
Provides fuel enrichment for cold engine starting.

**ACCELERATOR PUMP**  
Adjustable accelerator pump system helps to provide instant throttle response, particularly in the lower RPM range.

**ACCELERATOR PUMP ADJUST SCREWS**  
Sets ON and OFF operation of accelerator pump in relation to throttle slide position.

**IDLE ADJUSTMENT SCREW**  
Controls engine idle speed.

**THROTTLE RETURN SPRING**  
A choice of positioning pegs allows adjustment of spring tension.

**PILOT AIR JET**  
Use in conjunction with the Pilot Fuel Screw for tuning of mixture at idle to 1/4 throttle.

**SMOOTH THROTTLE BORE/VENTURI**  
Produces the optimum air and fuel mixture flow at all RPMs.

**JET NEEDLE CLIP**  
Has easy adjustment feature for quick tuning.

**FLAT THROTTLE VALVE DESIGN**  
Provides the strongest signal for precise and instantaneous throttle response.

**GENUINE MIKUNI JETS**  
Provide for precise fuel metering.

**FLOAT BOWL VENT**  
Allows atmospheric pressure into float bowl for fuel flow.

**ACCELERATOR PUMP SPRAY NOZZLE**  
Shoots fuel directly into the intake tract for immediate engine response.

The Mikuni RS Series Carburetors were designed and built in response to the needs of the world's top motorcycle road race and drag race teams. They required carburetors which could satisfy the precise fuel metering demands and high flow volume required by highly modified race engines. And yet, also provide the smooth, controllable throttle response that is needed by any rider pushing his motorcycle to its limits on the race track and under any high performance applications. The carburetors need to meter fuel correctly under a wide range of atmospheric conditions and engine tuning modifications while being easily accessible for trackside

tuning changes which need to be made quickly.

Designed for in-line four cylinder performance motorcycle applications, the Mikuni RS Series Radial Flat Slide Carburetors offer superior horsepower gains with their maximum flowing smoothbore induction tract and radial flat slide design. An adjustable accelerator pump system helps to provide instant throttle response, particularly in the lower RPM range. The RS Series Carburetors feature a compact design which is 25% lighter than other performance carburetors and uses readily available Mikuni jets. Available in 34, 36, 38, and 40mm sizes.

## RS SIZE / FITMENT & STANDARD TUNING SPECIFICATIONS

MIKUNI KIT NUMBER	APPLICATION *(GENERAL)	CARB SPACING (Throttle Shaft No.) A-B-C	SPIGOT (O.D.) MM	MAIN JET (N100.604)	*JET NEEDLE (J8-) (CLIP POS.)	NEEDLE JET #568 (784-13002)	PILOT JET (VM28/486)	PILOT SCREW (TURNS)
RS34-D21-K	GSX-600 '88 GSX-R 750 to 1990 SUZ GS 750 ALL KAW KZ 750	77-93-77 (700-17011)	40	115	9DZH1 (-3)	P-4	17.5	1/4-1/2
RS36-D3-K	GSX-R 750 to 1990 GSX-R1100 to 1990 GS 1000-1150 KZ 1000-1100	77-93-77 (700-17011)	42	120 120 130 130	9DZH1 (-3)	P-4	17.5	1/4-1/2
RS38-D19-K	GSX-R 750 to 1990 GSX-R1100, GS 1000-1150 KZ 1000-1100	77-93-77 (700-17011)	42	135 135 135	9CHY3 (-2)	Y-6	17.5	1/4-1/2
RS40-D1-K	GSX-R '90, GS, KZ RACE	77-93-77 (700-17011)	44	140	9CHY3 (-3)	Y-6	17.5	1/4-1/2

KIT PREFIX NUMBER DENOTES CARB VENTURI SIZE IN MILLIMETERS.  
EG: RS36 = 36MM BORE.

\*NOTE: THESE ARE GUIDELINES ONLY, OTHER APPLICATIONS MAY BE AVAILABLE CONTACT YOUR MIKUNI DISTRIBUTOR SPECIFICATIONS ARE SUBJECT TO CHANGE.

\*NOTE: RS34/36  
MAY USE 9DZH05  
RS38/40 MAY USE  
9CHY10

CARBURETOR SPACING:  
(mm)

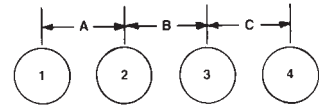

PARTS STAMPING  
This marking is your quality assurance guarantee.  
DO NOT ACCEPT SUBSTITUTES.

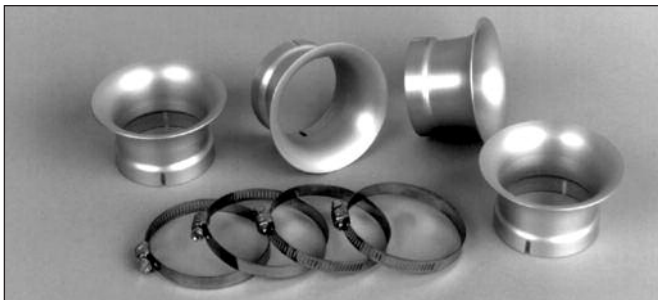

**IMPORTANT:** Mikuni RS Series Carburetors are legal in California ONLY FOR RACING VEHICLES WHICH MAY NEVER BE USED UPON A PUBLIC STREET OR HIGHWAY. In other locations check for similar laws which may apply.

### MIKUNI PUSH/PULL THROTTLE ASSEMBLY

A Push/Pull Throttle Assembly is required with the use of all Mikuni Racing Carburetors to assure the positive closing of the carburetor throttle slides against the high vacuum pressures encountered in racing engines. The Mikuni Push/Pull Throttle Assembly includes a twist throttle assembly and both throttle cables with adjusters.

**Push/Pull Throttle Assy.**

**Part No. KRS-001**

### MIKUNI VELOCITY STACKS

Velocity stacks improve the air flow into the carburetors to increase induction efficiency and increase horsepower on racing engines where air filters are not required. Set of 4 Velocity Stacks fits all Mikuni RS Series Carburetors and other carburetors with 55mm O.D. intake bells. Choose length depending on chassis clearance and desired tuning characteristics.

**30mm Mikuni Velocity Stacks, Part No. KRS-002**

**50mm Mikuni Velocity Stacks, Part No. KRS-003**

**70mm Mikuni Velocity Stacks, Part No. KRS-004**

**15mm Mikuni Velocity Stacks, Part No. KRS-007**

### MIKUNI RS METHANOL KIT

All the jetting components necessary to allow the use of methanol fuel with RS38 and RS40mm carburetors.

**Mikuni RS Methanol Kit**

**Part No. KRS-005**

# RS Replacement

## RS34/36/38/40 Radial Flat Slide Smoothbore Carbs

### Exploded View

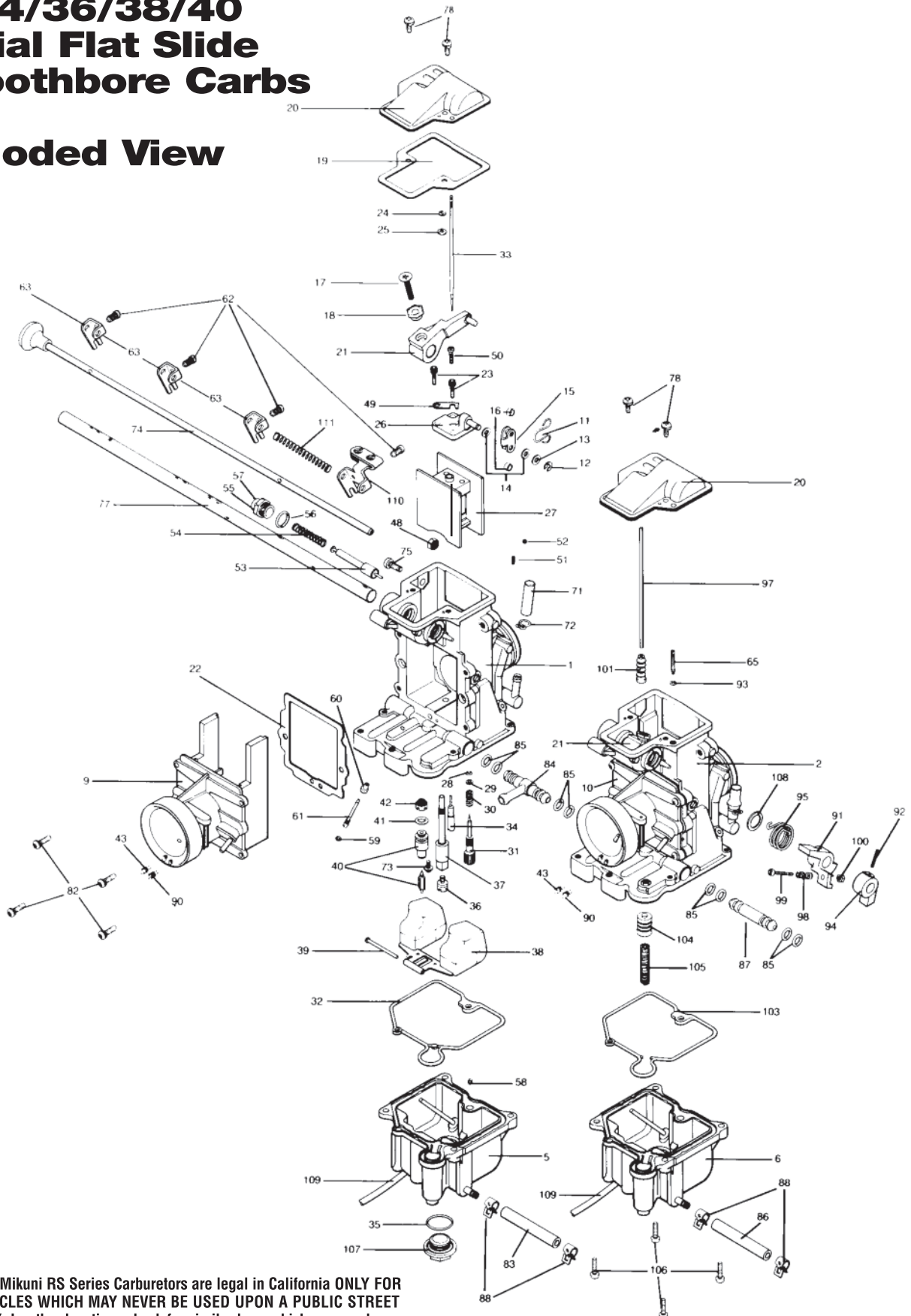

**IMPORTANT:** Mikuni RS Series Carburetors are legal in California ONLY FOR RACING VEHICLES WHICH MAY NEVER BE USED UPON A PUBLIC STREET OR HIGHWAY. In other locations check for similar laws which may apply.

# Parts

No.	Description	Part Number
1	MIXING BODY	TM36SS54
2	MIXING BODY	TM36SS55
3	MIXING BODY	TM36SS56
4	MIXING BODY	TM36SS57
5	FLOAT CHAMBER BODY	TM36/60
6	FLOAT CHAMBER BODY	TM36/71
7	FLOAT CHAMBER BODY	TM36/73
8	FLOAT CHAMBER BODY	TM36/75
9	AIR FUNNEL BODY	TM36/27a
10	AIR FUNNEL BODY	TM36/28a
11	CLIP, T.V. LEVER	TM27/05A
12	E-RING, T.V. LEVER	BSW28/70
13	WASHER, T.V. LEVER	M10/56
14	PACKING, T.V. LEVER	B401/10
15	PLATE, T.V. LEVER	TM27/04
16	RING, T.V. LEVER	TM20/65
17	SCREW, SYNCH. LOCK	C5 = 0518
18	RING, SYNCH. ADJUST	TM36/06
19	GASKET, TOP COVER	TM36/39
20	TOP COVER, CARB.	TM36/60
21	LEVER ASSY, T.V. #1-2-4	TM36/51
22	GASKET, A/FUNNEL	TM36/42
23	SCREW, 2.5 mm ALLEN	739-13001
24A	E-RING, RS34-36 NDLE	VM20/369
24B	E-RING, RS38-40 NDLE	BS32/126
25A	WASHER, NDLE CLIP 34-36	VM26/315
25B	WASHER, NDLE CLIP 38-40	826-03002
26	CONNECTOR PLATE, T.V.	TM36/54
27A	VALVE, THROTTLE 34-36	CALL YOUR DISTRIBUTOR
27B	VALVE, THROTTLE 38-40	
28	O-RING, FUEL SCREW	N133.037
29	WASHER, FUEL SCREW	VM12/33
30	SPRING, FUEL SCREW	N133.206
31	SCREW, PILOT FUEL	604-26003
32	O-RING, F.C.B. #1-3-4	616-94020
<b>33A</b>	<b>JET NEEDLE RS36 BEFORE 12/87</b>	<b>J8-9CHY01</b>
<b>33B</b>	<b>JET NEEDLE RS34, 36</b>	<b>J8-9DZH01 or 9DZH05</b>
<b>33C</b>	<b>JET NEEDLE RS38, 40</b>	<b>J8-9CHY03 or 9CHY10</b>
<b>34</b>	<b>PILOT JET</b>	<b>VM28/486-17.5</b>

No.	Description	Part Number
35	O-RING, DRAIN PLUG	VM28/254
<b>36</b>	<b>MAIN JET</b>	<b>N100-.604</b>
<b>37</b>	<b>NEEDLE JET-568</b>	<b>784-13002-P-4</b>
38	FLOAT ASSY	<del>859-32011</del>
39	PIN, FLOAT	VM30/160
40	NEEDLE VALVE ASSY	N149.040-2.8
41	O-RING, NEEDLE VALVE	KV/10
42	FILTER, NEEDLE VALVE	VM18/233
43	MAIN AIR JET (PLUGGED)	BS30/97
44	SCREW, CRANK BRACKET	C8 = 0512
45	LEVER ASSY, T.V. #3 CARB	TM36/67
46	SCREW LEVER	CS = 0514
47	PACKING, SHAFT	VM28/474
48	HEXAGON, LOCK NUT	VM18/267
49	PLATE, NEEDLE RETAINER	TM36/42
50	SCREW, T.V. PLATE	C2-0310
51	SPRING, STARTER SHAFT	B21/29
52	BALL, STARTER SHAFT	B21/28
53	PLUNGER, STARTER	N151.038
54	SPRING, STARTER	VM16/42
55	GUIDE HOLDER, STARTER	<del>640-12002</del>
56	O-RING, STARTER	N138.198
57	CAP, STARTER	<del>N106.211</del>
58	STARTER JET	VM17/1002
59	O-RING, A/P NOZZLE	N124.063
60	PLUG, A/P NOZZLE	TM29/14
61	PUMP NOZZLE	TM36/43
62	SCREW, START BRACKET	N158.052
63	LEVER, STARTER SHAFT	<del>N178.656</del>
64	BRACKET, BELL CRANK	TM36/37a
65	ADJUST SCREW, A/P	TM36/48A
66	LEVER ASSY, BELL CRANK	TM36/31
67	HEXAGON NUT, A/P	<del>N2-03-B</del>
68	PIN, THROTTLE BELL CRANK	N138.019
69	ADJUSTER, IDLE	739-55003
70	SPRING, IDLE ADJUSTER	N110.209
71	CAP, VACUUM FITTING	N148.013
72	SPRING CLIP, VAC. FIT	BVK28/128
73	SCREW, NV HOLDER	VM13/216
74	SHAFT ASSY, STARTER	<del>TM36/34a</del>
75	PAN HEAD MACHINE SCREW	C2=0508-B
76	FLAT HEAD MACHINE SCREW	C5 = 0514
77A	SHAFT, THROTTLE B/C #3	700-17011
77B	SHAFT, THROTTLE B/C #1	700-17012
77C	SHAFT, THROTTLE B/C #3	700-17013
78	SCREW, TOP COVER	CW2=0408
79	SPRING, THRTL. RTRN.	TM36/46a
80	LEVER, RTN. SPRING	<del>TM36/33</del>
81	CAP, SHAFT END	<del>TM33/36-A</del>
82	SCREW, AIR FUNNEL	VM38/133B
83	HOSE, FUEL CONNECT	888-44003
84	INLET, FUEL "T"	<del>701-23018</del>
85	O-RING, FUEL JOINT	616-23002
86	HOSE, A/P FUEL	<del>888-4404</del>
87	JOINT, FUEL	792-20014
88	CLIP, FUEL HOSE	E100729-BB
89	SCREW, BRACKET	C2 = 0512-B
<b>90</b>	<b>PILOT AIR JET</b>	<b>BS30/97-0.8</b>
91	LEVER, A/PUMP	TM36/17
92	PIN, A/P LOCATE	BN38/43
93	O-RING, A/P ADJ.	B30/205
94	LEVER, A/PUMP	TM36/18
95	SPRING, A/PUMP	TM36/45
96	PLATE, TOP BRACKET	<del>TM36/25</del>
97	ROD, A/PUMP	TM36/44
98	SPRING, A/P ADJ.	M12F/46A
99	SCREW, A/P ADJ.	MC-0316-B
100	HEXAGON NUT, A/P ADJ.	N3 = 03-B
101	CAP, A/P RUBBER	TM36/64
102	PLATE, LOWER BRACKET	<del>TM36/36</del>
103	O-RING, F.C.B. A/P	616-94021
104A	PLUNGER, A/PUMP 8mm	TM36/60
104B	PLUNGER, A/PUMP 12mm	TM36/60a
105	SPRING, A/P 12mm	VM14SC13/89
106	SCREW, FLOAT BOWL	C2 = 0412-B
107	PLUG, DRAIN	VM33/77
108	RING, A/P SPRING	<del>E204.040</del>
109	HOSE	888-23026
110	LEVER, STARTER CABLE	TM36/63
111	SPRING, STARTER BRACKET	730-06027
112	BRACKET, STARTER CABLE	TM36/61

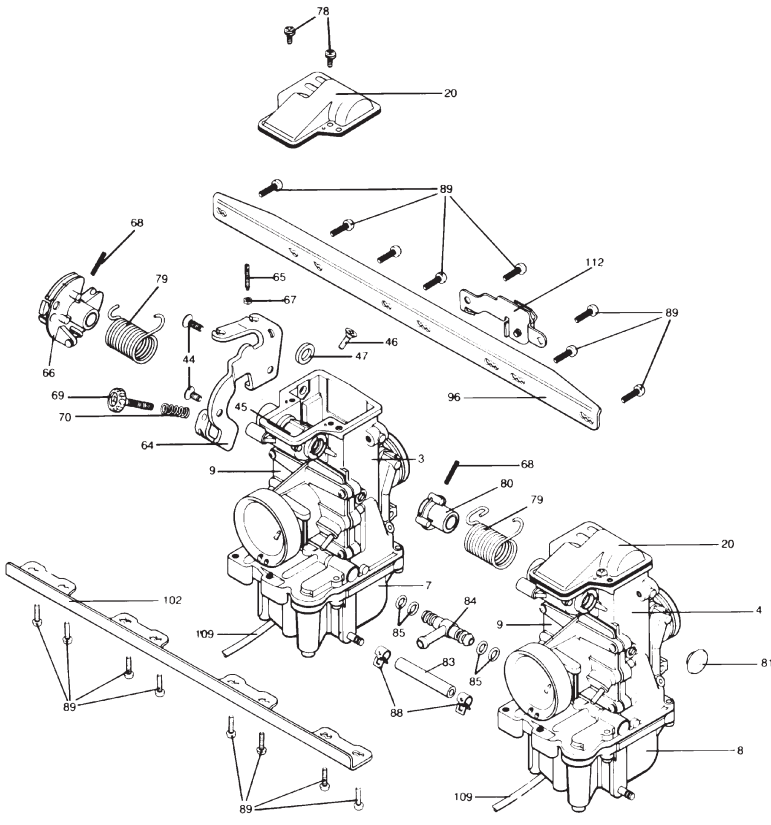

PART NUMBER (000-000) = NO AVAILABLE STOCK

# TMX Series Carbs

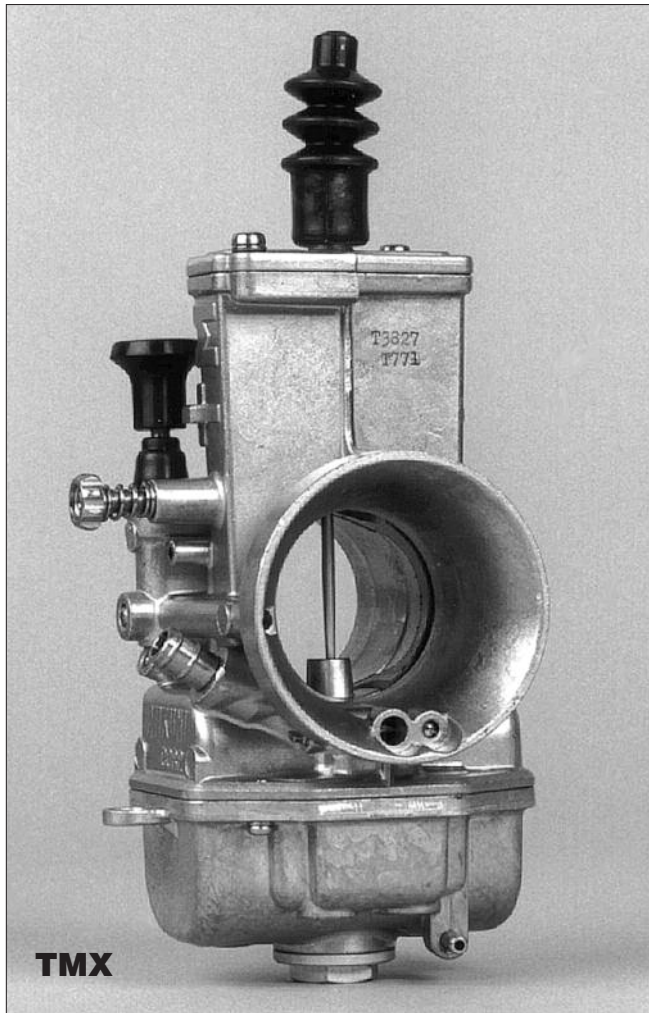

## TMX35/38mm CARBURETORS FOR DIRT BIKES and ATVs

The TMX features a flat slide design in a smooth bore venturi to provide improved throttle response and wider powerband. The float system with independently moving floats, working with a main jet enclosed in a baffle chamber, allows the TMX to perform smoothly without hesitation on the roughest terrain. TMX Series Carburetors are available in 35mm bore sizes for 125cc race engines, and in 38mm bore sizes for use on 250cc race engines.

### STANDARD SETTINGS

CARB NO.	MAIN JET 4/042	PILOT JET VM22/210	JET NEEDLE	THROTTLE VALVE
TM35-1 *(Kit No. TMX35-1-k)	350	20	6EN11-53	999-832-014-6.0
TM38-18 *(Kit No. TMX38-18-k)	370	20	6EJ12-55	999-832-014-3.5
TM38-27 *(Kit No. TMX38-27-k)	370	20	6EJ12-55	999-832-014-3.5

\*NOTE: COMPLETE KIT INCLUDES AIR BOOT ADAPTER, INNER THROTTLE CABLE WIRE, CABLE END, MAIN JETS, PILOT JETS, JET NEEDLE, CLAMPS, HOSE AND INSTRUCTIONS.

Mikuni TMX Series Carburetors are intended for off-road riding and racing use only. Not legal for sale or use in California or other locations where similar pollution laws may apply.

### TMX/TMS SERIES CARBURETOR DIMENSIONS (mm)

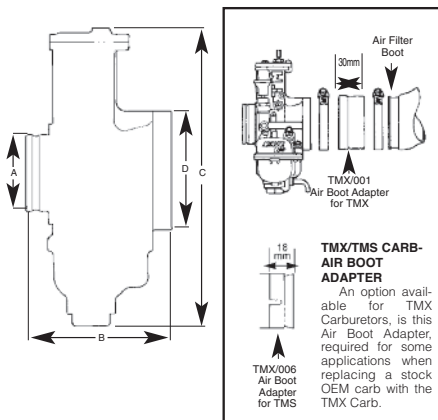

MODEL	TMX35	TMX38-27	TMX38-18
DIMENSION	-1		
A	40	44	47
B		76	
C		164	
D		62	
TOTAL WIDTH		76	

### IMPORTANT TUNING CHARACTERISTICS

#### JET NEEDLE

The Jet Needle is the tapered rod that is positioned in the throttle valve by the 'E'-Clip. The taper of the needle increases the clearance between the Jet Needle and the fixed Needle Jet outlet as the throttle is opened. As the air flow volume increases past the throttle slide, the fuel volume is also increased to maintain the correct air/fuel ratio.

#### NEEDLE 'E'-CLIP POSITION

The position of the 'E'-Clip in the Jet Needle is used to correct or change the air/fuel ratio between 1/4th and 3/4th throttle valve position. The 'E'-Clip can be raised or lowered on the Jet Needle. To richen the fuel mixture the 'E'-Clip is lowered on the Jet Needle, raising the Jet Needle. To lean the fuel mixture the 'E'-Clip is raised on the Jet Needle.

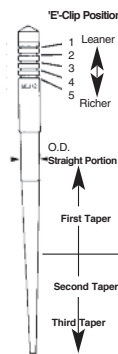

### JET NEEDLES

To correct the fuel mixture at 1/8th to 1/4th throttle slide position it may be necessary to change the Jet Needle. The Jet Needle will have a series of numbers stamped on it.

Example: 6EJ12-55. The numbers 55 indicate that the outside diameter (O.D.) of the Jet Needle is 2.55mm. A smaller O.D. number gives a richer mixture. A larger O.D. number gives a leaner mixture. Typical Jet Needles available:

TMX35	TMX38
6EN11-58 Leaner	6EJ12-60 Leaner
6EN11-57	6EJ12-59
6EN11-56	6EJ12-58
6EN11-55	6EJ12-57
6EN11-54	6EJ12-56
6EN11-53	6EJ12-55
6EN11-51 Richer	6EJ12-54
	6EJ12-53 Richer

## TMX35/38 Series Exploded View

### MIKUNI TMX SERIES PART LIST

No.	Description	Part Number
1.	MIXING BODY CARB	TM38SS44
2.	JET NEEDLE	J8-SEE TUNING
3.	COVER, CARB TOP	776-19014
4.	LOCK NUT, ADJUSTER	B30/247
5.	CAP, RUBBER	VM34/282
6.	ADJUSTER, CABLE	VM30/77
7.	O-RING, TOP COVER	616-93009
8.	E-RING, NEEDLE CLIP	BS32/126
9.	RING, RETAINING	TM38/54
10.	ADJUSTER, IDLE STOP	603-25008
11.	SPRING, IDLE ADJUST	N110209
12.	PLUNGER, STARTER ASSY	TM38/57
13.	SCREW, AIR ADJUSTER	603-36002
14.	SPRING, AIR SCREW	VM15/112
15.	CHAMBER, FLOAT BOWL	TM38/48
16A.	VALVE SEAT, NDLE ASSBLY	786-36004-(3.5)
16B.	VALVE SEAT, NDLE ASSBLY	786-36004-A-(1.8)
17.	PILOT JET	VM22/210-SEE TUNING
18.	MAIN JET	4/042-SEE TUNING
23.	CAP, FLOAT RETAINER	VM26/42
24.	SCREW, TOP COVER	CW2=0412
25A.	THROTTLE VALVE	999-832-014
25B.	THROTTLE VALVE	999-832-017
26.	SPRING T.V.	730-13019
27.	HOSE, VENT	888-24011
28.	SCREW, FLOAT BOWL	CW2-0308
29.	HOSE, OVERFLOW	888-23022
30.	FLOAT, LEFT SIDE	859-52021
31.	O-RING, DRAIN PLUG	BN042/64
32.	DRAIN PLUG	TM38/44
33.	FLOAT, RIGHT SIDE	859-52020
34.	GASKET, FLOAT BOWL	TM38/52

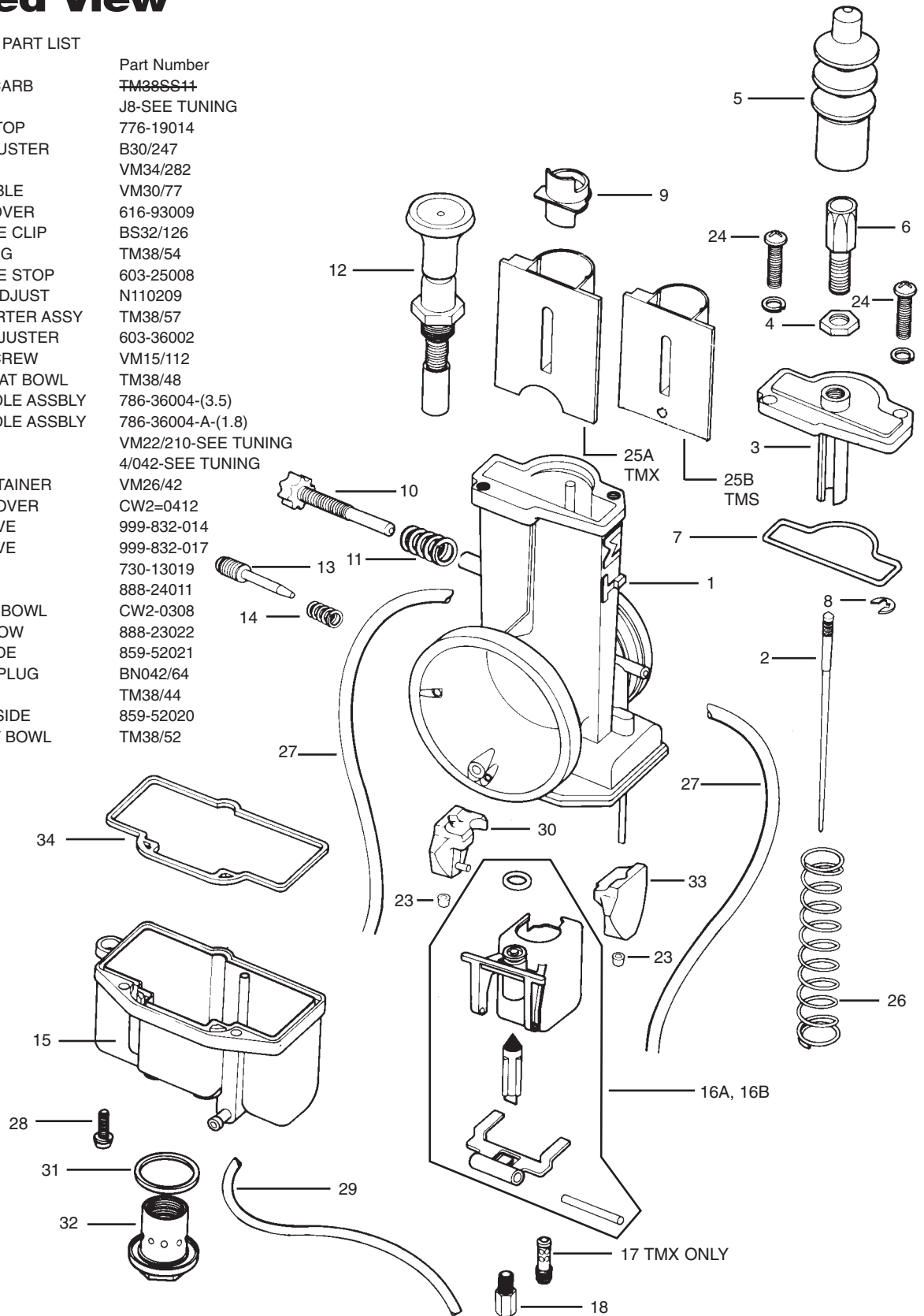

PART NUMBER 000-000 = NO AVAILABLE STOCK

## TM33-8012 Series Exploded View / Replacement Parts

### MIKUNI TMX SERIES PART LIST

No.	Description	Part Number
1.	SCREW, TOP COVER	CW2=0410
2.	TOP COVER	TM29/46a
3.	GASKET, TOP COVER	TM29/17
4.	SCREW, JOINT ASSY	793-13004
5.	JOINT ASSY	TM29/74
6.	E-RING	VM20/369
7.	PACKING	VM26/315
8.	JET NEEDLE	J8-5FP96-3
9.	THROTTLE VALVE	832-38007-1.5
10.	GASKET, AIR FUNNEL	TM29/62
11.	HOSE, VENT	VM34/105
12.	AIR FUNNEL	TM33/32a
13.	SCREW, AIR FUNNEL	VM38/133
14.	PILOT AIR JET	BS30/97-1.1
15.	MAIN AIR JET	BS30/97-0.7
16.	SPRING, IDLE ADJUSTER	730-07008
17.	IDLE ADJUSTER	TM33/38a
18.	CLIP, IDLE ADJUSTER	N180-160e
19.	PIN FLOAT	VM30/160
20.	FLOAT ASSY	859-34003
21.	NEEDLE VALVE ASSY	N133.200-1.8
22.	SCREW, NEEDLE VLV. HOLDER	VM13/216
23.	O-RING, NEEDLE VALVE	KV/10
24.	FILTER, NEEDLE VALVE	VM18/233
25.	RING (NYLON), MAIN JET	TM33/36a
26.	RING (BRASS), MAIN JET	VM38/106a--z
27.	MAIN JET	N100.604-127.5
28.	PILOT JET	VM28/486-37.5
29.	O-RING, FLOAT BOWL	616-94012
30.	DRAIN SCREW, FLOAT BOWL	N133.363
31.	FLOAT BOWL	TM33/77
32.	HOSE, OVERFLOW	888-23043-1F
33.	SCREW (LONG), FLOAT BOWL	C2=0416
34.	SCREW (SHORT), FLOAT BOWL	C2=0414
35.	O-RING, A/P NOZZLE	N124.063
36.	A/P NOZZLE	TM29/24
37.	PLUG, A/P NOZZLE	TM29/14
38.	PILOT SCREW	N138.192
39.	SPRING, PILOT SCREW	N138.187
40.	WASHER, PILOT SCREW	VM12/33
41.	O-RING, PILOT SCREW	N133.037
42.	HOSE, VENT	888-26020-1E
43.	SPRING, A/P PLUNGER	730-04003a
44.	A/P PLUNGER	TM29/18
45.	CAP, A/P PLUNGER	N150.048
46.	ROD, A/P	TM33/46
47.	BOLT, A/P LEVER	B30/397
48.	LEVER A/P	VM38/212
49.	SPRING, A/P LEVER	TM33/47a
50.	MAIN BODY	TM33e00/04-0
51.	SCREW, THROTTLE BRACKET	C5=0510
52.	THROTTLE BRACKET	TM33/33
53.	BELLCRANK	TM33/44
54.	SPRING, THROTTLE RETURN	TM24/24
55.	PACKING, THROTTLE SHAFT	B36/95
56.	LEVER, THROTTLE	VM13/186
57.	WASHER, THROTTLE LEVER	W4=05
58.	BOLT, THROTTLE LEVER	VM28/230
59.	SPRING, LINKAGE LEVER	VM33/49e
60.	PLATE LINKAGE LEVER	VM33/45
61.	WASHER, LINKAGE LEVER	M10/56
62.	E-RING, LINKAGE LEVER	BSW28/70
63.	PACKING, LINKAGE LEVER	B40i/10
64.	CHOKE ASSY	TM33/49
65.	O-RING, CHOKE ASSY	N138.198
66.	NEEDLE JET	784-24111-P-8

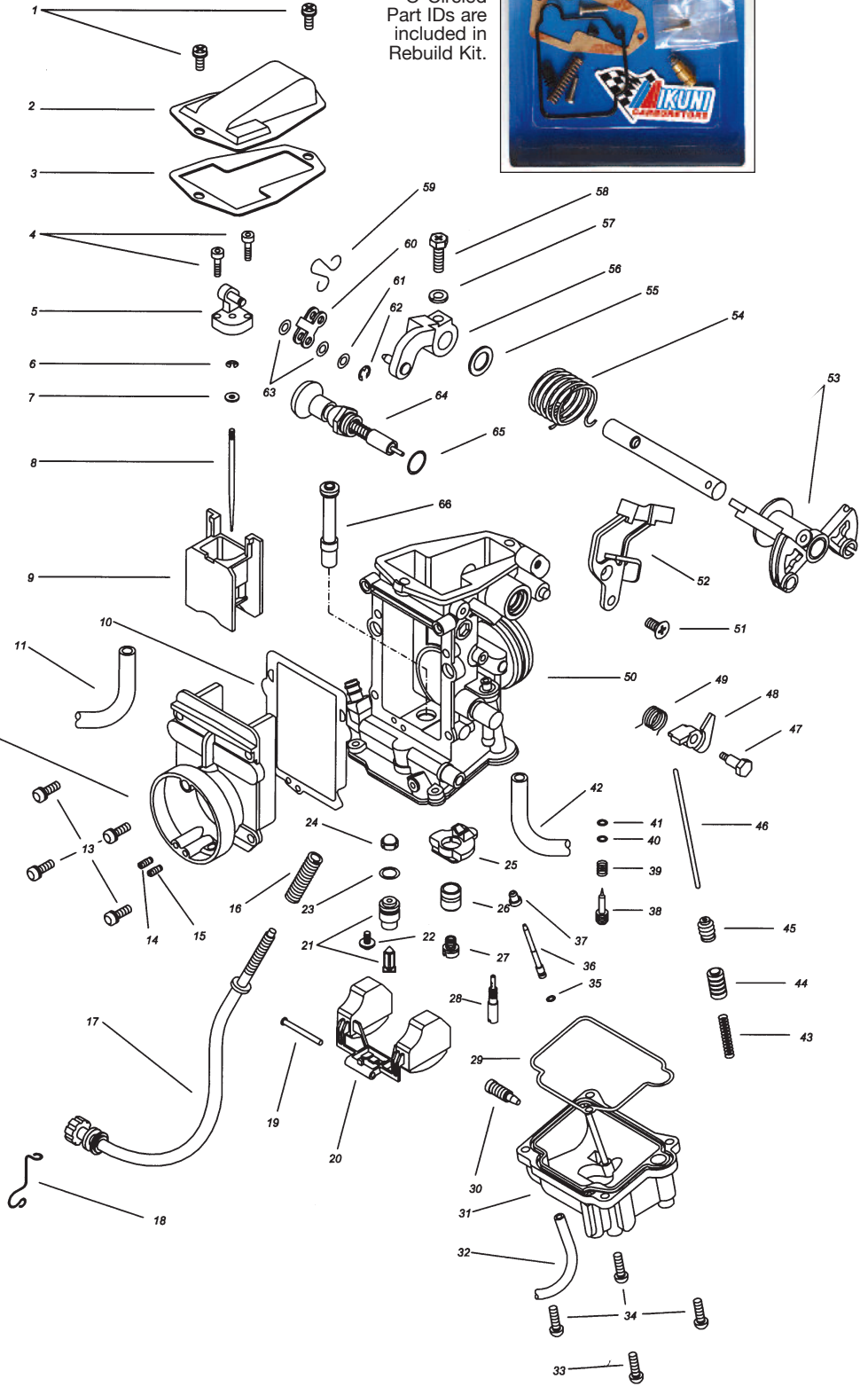

**MK-8012 Rebuild Kit**  
O-Circled Part IDs are included in Rebuild Kit.

PART NUMBER 000-000 = NO AVAILABLE STOCK

**MK-8012 Rebuild Kit** O-Circled Part IDs are the parts included in Rebuild Kit.



# TM Carburetors

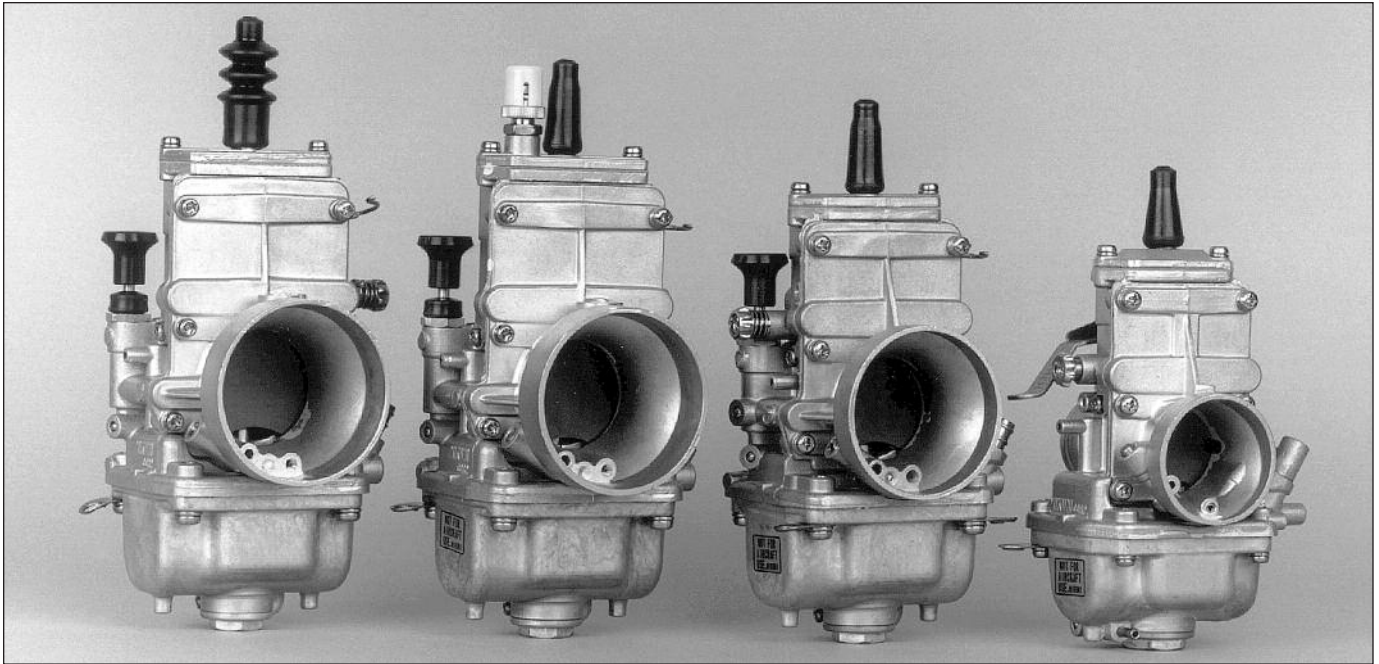

## FLAT SLIDE CARBURETORS

Mikuni's TM Series flat side carburetors provide a significant performance improvements over older round slide carburetors. Air flows faster, smoother through the TM Series venturi and jet blocks due to the flat slide design which help create a smooth bore effect. The high velocity air flow means a stronger vacuum at the needle jet for more precise metering, better throttle response.

## POWER JET KITS

Power Jet Kits are used in two-stroke engine applications to improve mid range throttle response and add additional fuel to wide open throttle running conditions, especially with snowmobile clutches.

### Power Jet Kit Universal MK-406

(See Power Jet Kit Installed on Carb on page 29).

## TM SERIES FLAT SLIDE CARBURETORS

CARB NO.	SIZE (MM)	MAIN JET (4/042)	PILOT JET (VM22/210)	NEEDLE JET/SERIES	JET NEEDLE	THROTTLE VALVE	AIR JET
TM24-8001	24	130	15	784-21005-Q-0/454	5N13	832-30005-3.0	None
VM28-418	28	180	15	VM30/46-P-8/175	5DP39	832-33001 2.5	None
TM32-1	32	250	45	785-24001-Q-2/389	5FP17	832-39012 4.0	None
TM34-2	34	280	50	785-24001-Q-2/389	5FP17	832-39012 4.0	None
TM36-2	36	280	50	785-24001-Q-6/389	6FJ40	832-43002a 4.0	None
TM38-85	38	230	22.5	785-24001-Q-2/389	6FJ41	832-43011-4.0	None
TM38-86	38	230	22.5	785-24001-Q-2/389	6FJ41	832-43011-4.0	None
TM33-8012	33 N100.604	127.5 VM28/486	37.5	784-241111-P-8/640	5FP96	832-38007-1.5	0.7
TM36-68*	36	" 130	"	784-13002-P-8/568	9DZH6-50	N/A	1.0
TM40-6*	40	" 165	"	784-13002-Y-6/568	J8-9DJY01	N/A	1.1

\*For TM36-68 exploded view & parts list see pg. 8

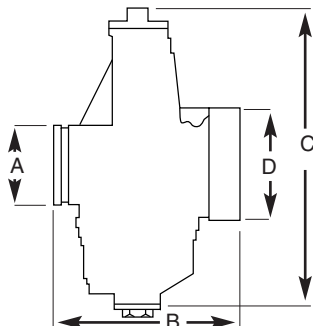

## TM SERIES FLAT SLIDE CARBURETOR DIMENSIONS

	MODEL NUMBER	TM24-8001	VM28-418	TM32-1	TM33-8012	TM34-2	TM36-2	TM36-68	TM38-85	TM38-86	TM40-6
DIMENSION A (mm)	A	31	33	40	40	40	43	42	47	43	44
B	B	75	82	83	93	83	100	100	100	100	100
C	C	145	135	160	160	160	170	176	170	170	165
D	D	44	44	58	50	58	62	54	62	62	55
TOTAL WIDTH		76	76	78	105	78	75	78	75	75	

# TM Replacement

ITEM#	DESCRIPTION	VM28-418	TM32-1	TM34-2	TM36-2	TM38-1 and 3	TM38-85 and 86
1	Complete Starter Assy	VM26/116 (Plunger )	VM29/47	VM29/47	VM29/47	VM29/47	VM29/47
2	Nylon Ring	VM28/1046	VM28/1046	VM28/1046	VM38/153	VM38/153	VM38/153
3	Screw W/Lockwasher	CW2 = 0310	CW2 = 0310	CW2 = 0310	CW2 = 0310	CW2 = 0310	CW2 = 0310
4	Cable Connector	VM28/1042	VM28/1042	VM28/1042	VM38/152	VM38/152	VM38/152
5	E-Ring	VM20/369	VM20/369	VM20/369	VM20/369	VM20/369	VM20/369
6	JET NEEDLE	J8-5DP39	J8-5FP17	J8-5FP17	J8-6F J40	J86F J40	J8-6F J41
7	Throttle Valve	832-33001-2.5	832-39012-4.0	832-39012-4.0	832-43002-4.0	832-43002-4.0	832-43011-4.0
8	Idle Rod	Not Applicable	Not Applicable	Not Applicable	VM38/159	VM38/159	Not Applicable
9	Mixing Chamber Body	Not Available	Not Available	Not Available	Not Available	Not Available	Not Available
10	Screw, Jet Block	VM38/132	VM38/132	VM38/132	VM38/132	VM38/132	VM38/132
11	Washer(Alum)	VM34/274	VM34/274	VM34/274	VM34/274	VM34/274	VM34/274
12	Jet Block, Left	<del>VM28/1064</del>	<del>VM34/402</del>	<del>VM34/430</del>	<del>VM36/163</del>	VM38/144	TM38/08
13	Jet Block, Right	<del>VM28/1065</del>	<del>VM34/403</del>	<del>VM34/440</del>	<del>VM36/164</del>	VM38/145	TM38/09
14	Float Pin	VM30/160	VM30/160	VM30/160	VM30/160	VM30/160	VM30/160
15	Float Arm	Not Applicable	VM36/15	VM36/15	VM36/15	VM36/15	VM36/15
16	Cap, Float Guide Pin	VM26/42	VM26/42	VM26/42	VM26/42	VM26/42	Not Applicable
17	PILOT JET	VM22/210-15	VM22/210-45	VM22/210-50	VM22/210-50	VM22/210-35	VM22/210-22.5
18	Float	VM28/694	VM24/236	VM24/236	VM24/236	VM24/236	859-52020/52021
19	Gasket, Float Chamber	VM26/228	VM34/374	VM34/374	VM34/374	VM34/374	VM34/374
20	Float Chamber Assy	<del>VM26/220-15</del>	TM32/02-60	TM32/02-80	TM32/02-100	TM32/02-100	TM38/138
21	Plate,Hose Retaining	<del>VM30/113</del>	<del>VM34/103</del>	<del>VM34/103</del>	<del>VM34/103</del>	<del>VM34/103</del>	<del>VM34/03</del>
22	Screw W/Lockwasher	CW2 = 0416	CW2 = 0516	CW2 = 0516	CW = 0518	CW2 = 0518	CW2 = 0516
23	O-Ring, Rubber	VM26/227	VM28/254	VM28/254	VM28/254	VM28/254	VM28/254
23a.	O-Ring, Flat Fiber Washer	4/053	4/053	4/053	4/053	4/053	4/053
24	Drain Plug, Std Aluminum	VM28/817	VM28/253	VM28/253	VM28/253	VM28/253	VM28/253
24a.	Drain Plug, Optional Brass		VM38/08	VM38/08	VM38/08	VM38/08	VM38/08
25	Cap, Idle Adjuster	Not Applicable	Not Applicable	Not Applicable	VM35/40	VM35/40	Not Applicable
26	Packing (Rubber)	Not Applicable	Not Applicable	Not Applicable	N138.077	N138.077	Not Applicable
27	Nut	Not applicable	Not Applicable	Not Applicable	N2 = 04	N2 = 04	Not Applicable
28	Idle Adjuster	Not Applicable	Not Applicable	Not Applicable	603-68001	603-68001	Not Applicable
29	Nut	Not Applicable	Not Applicable	Not Applicable	BDC36/35	BD36/35	Not Applicable
30	Rubber Cap	VM26/46	VM18/228	VM18/228	VM18/228	VM18/228	Not Applicable
31	Screw W/ Lockwasher	CW2 = 0412	CW2 = 0412	CW2 = 0412	CW2 = 0412	CW2 = 0412	CW2 = 0412
32	Cable Adjuster	M18F/43a	VM36/83	VM36/83	VM36/83	VM36/83	VM36/83
33	LockNut	B30/247	B30/247	B30/247	B30/247	B30/247	B30/247
34	Mixing Chamber Top	<del>776-15001</del>	<del>776-17001</del>	<del>776-17001</del>	776-19002	776-19002	776-19001
35	Gasket, Top	VM28/1045	VM32/495	VM32/495	VM38/127	VM38/127	VM38/127
36	Throttle Valve Spring	730-15001	730-15004	730-15004	730-16003	730-16003	730-16003
37	NEEDLE JET	VM30/46-P-8(175)	785-24001-Q-2(389)	785-24001-Q-2(389)	785-24001-Q-2(389)	785-24001-Q-2(389)	785-24001-Q-2(389)
38	Ring, Main Jet (Assy)	VM28/429	VM34/454	VM34/454	VM34/454	VM34/454	TM34/36
39	MAIN JET	4/042-180	4/042-250	4/042-280	4/042-280	4/042-290	4/042-230
40	O-Ring	VM24/559	KV/10	KV/10	KV/10	KV/10	KV/10
41	Needle Valve	VM24/557-2.5	786-46001-3.3	786-46001-3.3	786-46001-3.3	786-46001-3.5	786-46001-3.5
42	Plate, Needle Valve	VM24/560	VM24/560	VM24/560	VM24/560	VM24/560	VM38/29
43	Screw	C2 = 0406	C2 = 0406	C2 = 0406	C2 = 0406	C2 = 0406	C2 = 0406
44	Vent Hose	<del>888-23008</del>	<del>888-24001</del>	<del>888-24001</del>	<del>888-24001</del>	<del>888-24001</del>	<del>888-24007</del>
45	Gasket, Front Cover	VM28/1044	VM38/126	VM38/126	VM38/126	<del>VM36/166</del>	VM38/126
46	Front Body, Air Intake	Not Available	Not Available	Not Available	Not Available	Not Available	Not Available
47	Bolt	Not Applicable	Not Applicable	Not Applicable	Not Applicable	BV15/27	Not Applicable
48	Screw	VM38/133-B	VM38/133-B	VM38/133-B	VM38/133-B	VM38/133-B	VM38/133-B
49	Air Screw, Pilot	VM20/584	VM24/622	VM24/622	VM24/622	VM24/622	VM24/622
50	Spring, Pilot Air Screw	M12F/46a	M12F/46a	M12F/46a	M12F/46a	M12F/46a	M12F/46a
51	Washer, Pilot Air Screw	Not Applicable	VM12/33	VM12/33	VM12/33	VM12/33	VM12/33
52	O-Ring, Pilot Air Screw	Not Applicable	N133.037	N133.037	N133.037	N133.037	N133.037
53	MAIN AIR JET	BS30/97-1.8	2.5 On Body	2.5 On Body	2.5 On Body	2.5 On Body	2.5 On Body
54	Overflow Hose	<del>888-23007</del>	<del>888-23014</del>	<del>888-23014</del>	<del>888-23014</del>	<del>888-23014</del>	VM24/328
55	Starter Jet	VM17/1002-15	VM17/1002-60	VM17/1002-80	VM17/1002-80	VM17/1002-100	VM17/1002-40
56	Idle Stop Screw	603-27002	603-16003	603-16003	Not Applicable	Not Applicable	603-16003
57	Spring Idle Screw	VM15/112	VM24/556	VM24/556	Not Applicable	Not Applicable	VM24/556
58	O-Ring	VM14/75	BV32/04	BV32/04	Not Applicable	Not Applicable	BV32/04
59	Washer	VM14/87	Not Applicable	Not Applicable	Not Applicable	Not Applicable	Not Applicable

## TM Flatslide Carburetor Exploded View

**Special Jet Needle For 38 Flatside Carbs**

RICH	6DP04
↕	6FJ40
↕	6FM46
LEAN	6FJ41 (Standard)

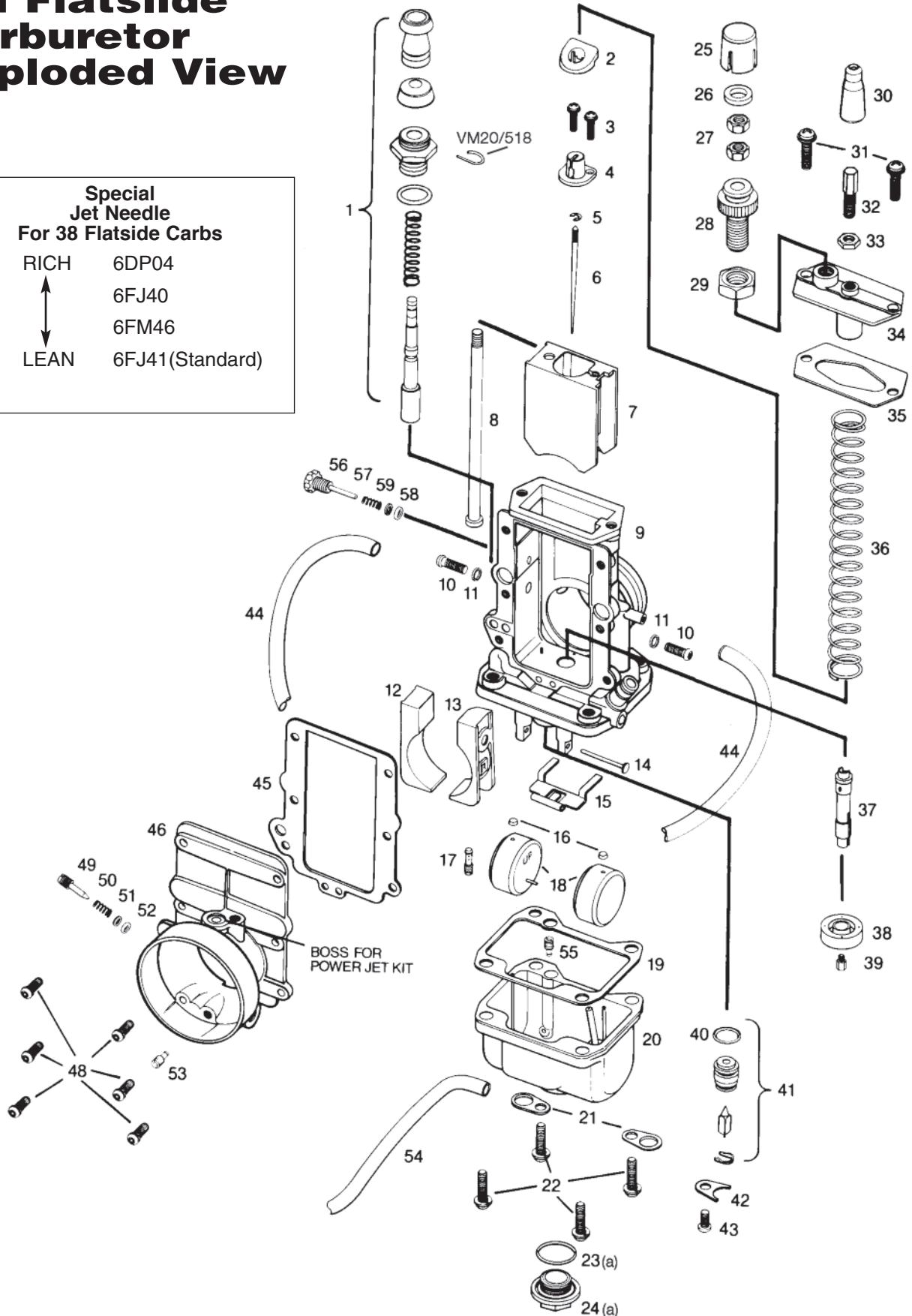

# VM Carburetors

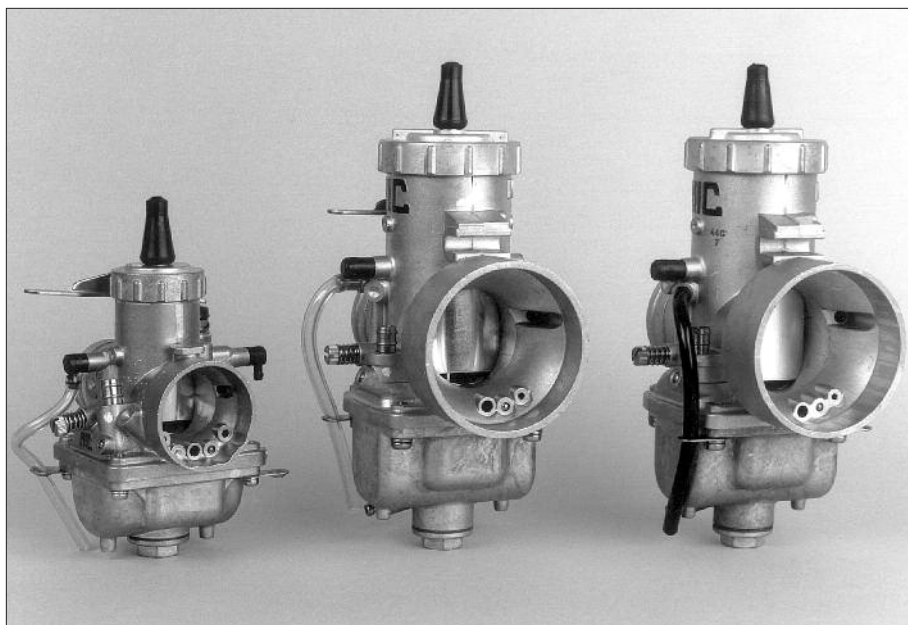

## MIKUNI VM ROUND SLIDE SINGLE CARBURETORS

These are the most popular high performance singles carburetors in the sport of motorcycling. Mikuni's are proven as the performance standard for use in single cylinder motorcycle and ATV applications for motocross, enduro and trail riding, flat track racing and road racing on both 2-stroke and 4-stroke engines.

Performance features for the VM Series Carburetors include a large selection of bore sizes for increased fuel mixture flow to match engine modifications. And the VM Series offers a wide range of tuning components to allow precise fuel mixture metering in any application, at any throttle setting, under any riding condition.

### ROUND SLIDE SINGLES MIKUNI CARBURETOR STANDARD SPECIFICATIONS

CARB NO.	SIZE (MM)	MAIN JET (4/042)	PILOT JET (VM22/210)	NEEDLE JET (Series No.)	JET NEEDLE	THROTTLE VALVE (Part No.)	MAIN AIR JET (Part No.)	NEEDLE VALVE (Part No.)
VM16-519*	16	70	25 (VM22/210)	D-8 (VM16/67)	3DJ3	2.5 (VM16/137)	0.5 (BS30/97)	3.3 (VM34/39)
VM18-144*	18	80	30	O-0 (145)	4F18	3.0 (VM18/158)	2.5 BODY	1.5 (VM15/172)
VM20-273*	20	180	22.5 (M28/1001)	O-6 / N-6 (239) (332)	4J13	2.0 (VM20/491)	0.5 (VM13/04)	1.5 (VM15/172)
VM22-133*	22	100	30	N-8 (257)	4D20	2.0 (VM26/21)	2.5 BODY	2.0 (VM26/26)
VM24-512	24	210	40	N-8 (864)	5L14-4	1.5 (VM26/21)	0.8 (MD13/24)	2.0 (VM26/26)
VM26-606	26	190	22.5 (M28/1001)	O-0 (332)	5E75	1.5 (VM24/361)	0.5 (VM13/04)	2.5 (VM26/26)
VM26-8074	26	190	60	N-8 (182)	5F21	2.0 (VM28/56)	0.5 (BS30/97)	2.5 (VM26/26)
VM30-83	30	250	40	P-5 (159)	6F5	2.5 (VM34/110)	2.0 (BS30/97)	3.3 (VM34/39)
VM32-193*	32	200	35	Q-6 (159)	6DP17	3.0 (VM32/65)	2.0 (BS30/97)	3.3 (VM34/39)
VM32-33	32	200	35	Q-6 (159)	6DP17	3.0 (VM34/110)	2.0 (BS30/97)	3.3 (VM34/39)
VM34-168*	34	260	35	Q-2 (159)	6DH4	2.5 (VM34/110)	2.0 (BS30/97)	3.3 (VM34/39)
VM34-275*	34	260	35	Q-2 (159)	6DH4	2.5 (VM32/65)	2.0 (BS30/97)	3.3 (VM34/39)
VM36-4	36	310	35	Q-5 (159)	6FJ6	2.5 (VM36/36)	2.0 (BS30/97)	3.3 (VM34/39)
VM38-9	38	330	30	Q-2 (166)	6DP1	2.5 (VM38/24)	0.5 (BS30/97)	3.3 (VM34/39)
VM44-3	44	310	35	AA-5 (224)	7F7	2.5 (VM44/23)	0.5 (BS30/97)	3.3 (VM34/39)

#### \*NOTES:

- VM18-144, VM16-159, CLAMP ON TYPE
- VM20-273, YSR50 FLANGE TYPE
- VM22-133, FLANGE TYPE

- VM32-193, RIGHT SIDE IDLE SCREW (MATCH TO VM32-33)
- All VM26 thru VM44mm, SPIGOT TYPE

- VM34-168, 11.5 MM. BELL, LG. FUEL INLET
- VM34-275, RIGHT SIDE IDLE SCREW (MATCH TO VM34-168)

## VM18-144 Exploded View

No.	Description	Part Number
1.	RUBBER CAP, THROTTLE CABLE	VM18/67
2.	CABLE ADJUSTER	M21/14
3.	NUT, CABLE ADJUSTER	B30/247
4.	TOP, MIXING CHAMBER	VM16/40
5.	SPRING, THROTTLE VALVE	VM18/170
6.	CLIP, JET NEEDLE RETAINING	VM18H1/38
7.	E-RING, JET NEEDLE POSITIONING	VM20/369
8.	JET NEEDLE	J8-4F18
9.	THROTTLE VALVE (SLIDE)	VM18/158-3.0
10.	RUBBER CAP, STARTER PLUNGER	VM20/455
11.	FITTING, STARTER PLUNGER	VM20/456
12.	SPRING, STARTER PLUNGER	VM16/42
13.	STARTER PLUNGER	VM18/144
14.	<del>SPRING PLATE, STARTER LEVER</del>	<del>VM18/161</del>
15.	STARTER LEVER	VM18/215
16.	<del>WASHER, STARTER LEVER</del>	<del>BV26/118</del>
17.	NUT, CLAMP BOLT	N1=05
18.	SEALING RING, RUBBER	VM18/326
19.	RING, INSULATOR	VM18/327
20.	PILOT JET	VM22/210-30
21.	NEEDLE JET	VM15H1/17-0-0
22.	MAIN JET	4/042-80
23.	GASKET, FLOAT BOWL	VM17/161
24.	FLOAT BOWL	VM18/161
25.	SCREW, FLOAT BOWL	CW2=0414
26.	AIR ADJUSTING SCREW	VM20/305
27.	SPRING, AIR ADJUSTING SCREW	VM15/112
28.	SPRING, IDLE ADJUSTING SCREW	VM15/112
29.	IDLE ADJUSTING SCREW	VM18/164
30.	BOLT, CLAMP	VM16/65
31.	WASHER, NEEDLE VALVE	VM15/07
32.	NEEDLE VALVE & SEAT ASSY.	VM15/172-1.5
33.	FLOAT	VM17/159
34.	PIN, FLOAT	BV26/22
35.	<del>HOSE OVERFLOW</del>	<del>VM13/06</del>

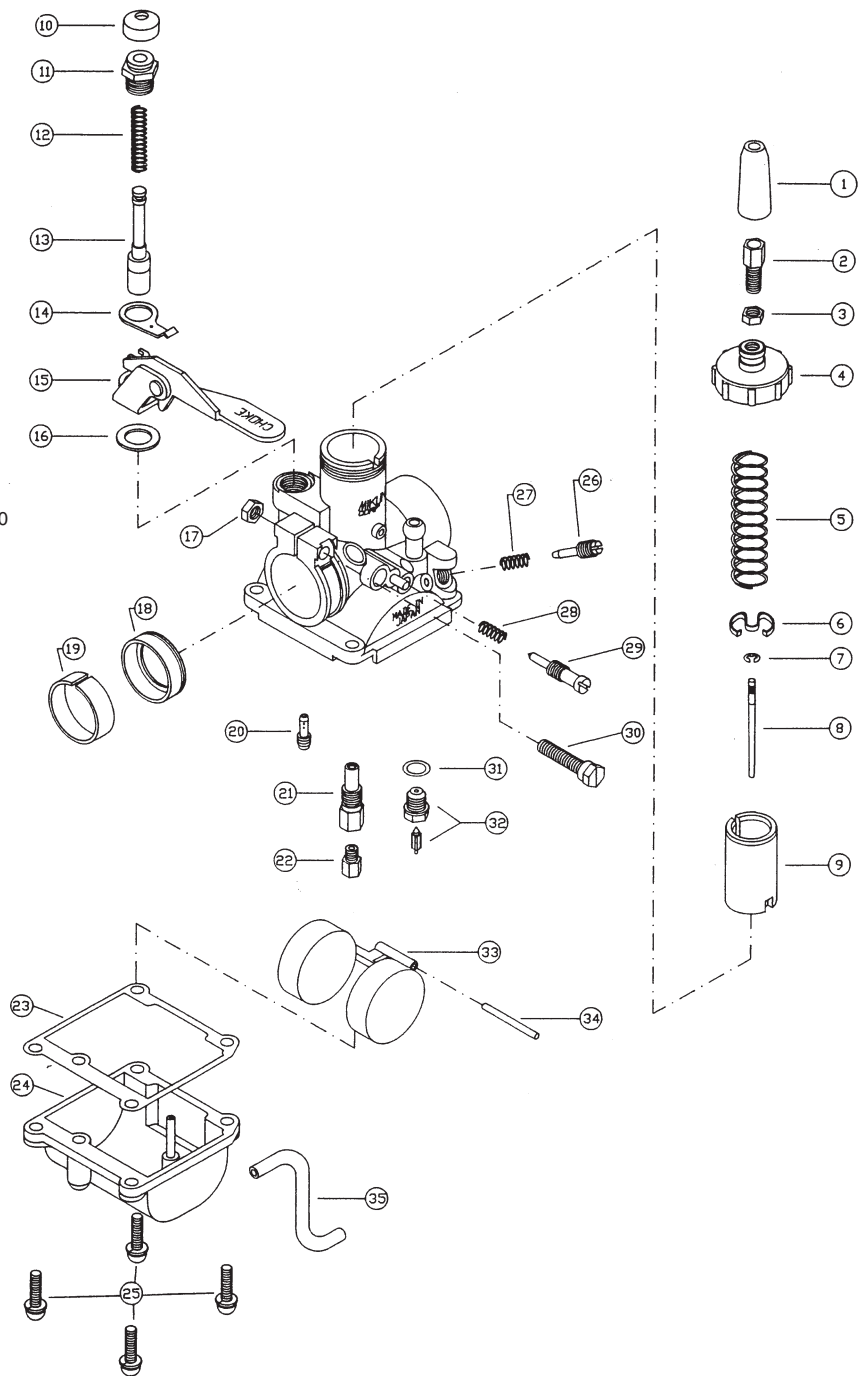

### VM SERIES ROUND SLIDE CARBURETOR DIMENSIONS(mm)

MODEL	VM18	VM20	VM22	VM24	VM26	VM30	VM32	VM34	VM36	VM38	VM44
<b>A</b>	CLAMP ON 22 ID	FLANGE 50.8 BOLT CTR	FLANGE 49 BOLT CTR	35	35	40		43		52	
<b>B</b>	67	66	85	80	93	93	102	93	116		
<b>C</b>	108	115	114	116	122	137	142	137	152	154	193
<b>D</b>	32	43	43	43	44	58		62		70	
<b>TOTAL WIDTH</b>	61	76.5	82	82	82	83		79			

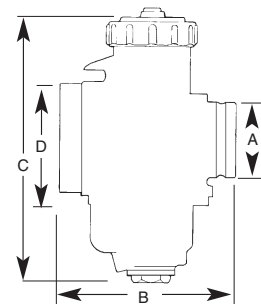

# VM Replacement

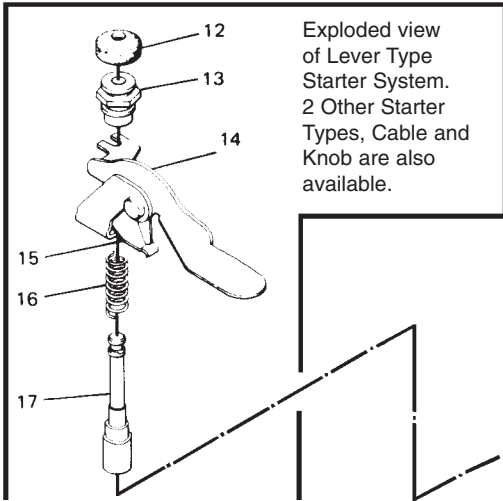

## Mikuni VM Spigot Mount Carburetor Exploded View



MK-404 Carb Tool Kit  
MK-403/1 Main Jet Hex Tool (included in Kit)



VM26 Rebuild Kit Part No. MK-606

Kit Parts	Description
VM26/26	Needle Valve Seat 2.5
VM26/25	Washer, Needle Valve
VM20/492	Bowl gasket
BN042.64	Drain Plug Gasket
VM14/73	Air Screw
VM14.75	O-Ring, Air Screw
VM15/11	Spring, Air Screw
603-16002	Idle Screw
BV32/04	O-Ring, Idle Screw
VM26/197	Spring, Idel Screw
VM20/369	E-Clip, Jet Needle
VM26/57	Gasket, Top Cover
VM26/46	Rubber Cap, Cable Guide
CW2=0416	Float Bowl Screws (4)

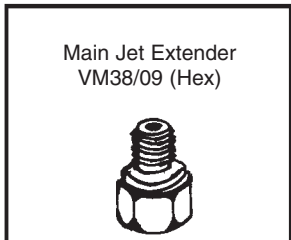
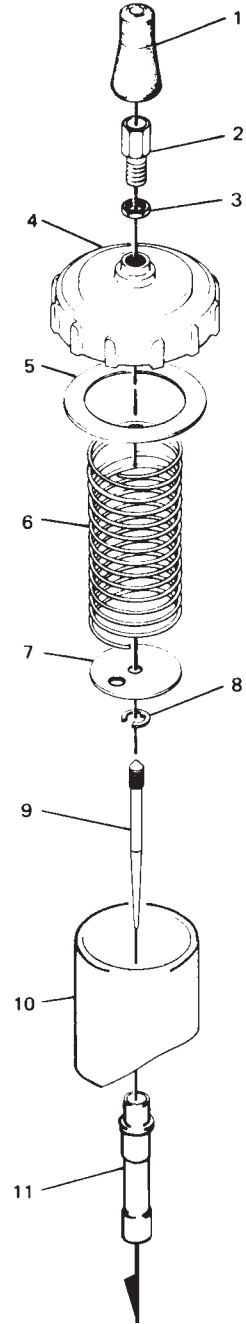
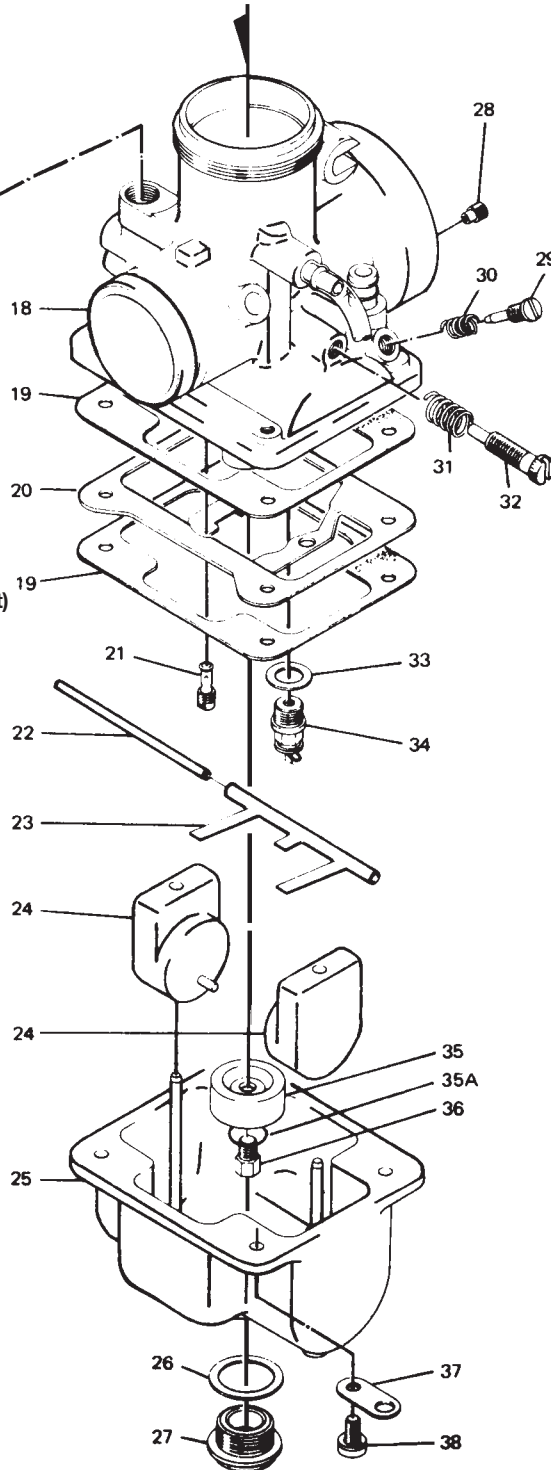

ITEM NUMBER and DESCRIPTION	VM26	VM28	VM30	VM32	VM34	VM36	VM38	VM40	VM44
1. RUBBER CAP, throttle cable			↔	↔ VM26/46	↔				
2. CABLE ADJUSTER			↔	↔ M21/14	↔				
3. LOCKNUT, cable adjuster			↔	↔ B30/247	↔				
4. TOP, mixing chamber	VM26/56			VM34/27		VM36/09		VM44/05	
5. GASKET, mixing chamber top	VM26/57			VM34/29		VM36/06			
6. SPRING, throttle valve	VM28/257		VM34/50		VM34/55			VM44/13	
7. PLATE, spring seat	VM28/132			VM34/31		VM35/09		VM44/09	
8. CLIP, needle positioning			↔	↔ VM20/369	↔			BS32/126	
9. NEEDLE	#5 Series			#6 Series				#7 Series	
10. THROTTLE VALVE (SLIDE)	VM28/56		VM34/110		VM36/36	VM38/24		VM40/02	
11. NEEDLE JET	VM28/86(182)   VM30/38(169)		VM34/05 159		VM34/17(166)			VM44/10(224)	
12. RUBBER CAP, starter plunger			↔	↔ VM20/455	↔				
13. FITTING, starter plunger	VM26/116				VM20/456				
14. LEVER, starter	VM28/135   VM28/497			VM28/124		VM32/53		VM36/58	
15. SPRING PLATE, starter level	VM26/09					VM32/17			
16. SPRING, starter plunger			↔	↔ VM16/42	↔				
17. PLUNGER, starter						VM18/144			
18. BODY, mixing chamber									
19. GASKET, float bowl	VM28/129		VM30/103 999-631-010			VM36/20		VM36/20	
20. BAFFLE PLATE, float bowl			VM34/72			VM36/40		VM44/12	
21. PILOT JET			↔	↔ VM22/210	↔				
22. PIN, float arm hinge			↔	↔ BV26/22	↔				
23. ARM, float	VM28/166			VM34/73		VM36/15			
24. FLOAT	VM28/164			VM34/61		VM24/236			
25. BOWL, float				VM34/68		VM36/07		VM44/04-80	
26. WASHER, main jet plug	VM28/134		4/053					VM28/134	
27. DRAIN PLUG, float bowl	VM28/133		VM34/42		VM28/253	VM38/08		VM28/133	
28. AIR JET			↔	↔ BS30/97	↔				
29. AIR ADJUSTING SCREW			↔	↔ VM20/214	↔				
30. SPRING, air adjusting screw			↔	↔ M12F/46A	↔				
31. SPRING, idle adjusting screw			↔	↔ M20/11	↔				
32. IDLE ADJUSTING SCREW	VM24/224	VM28/142	VM24/224			VM22/171		VM24/224	
33. WASHER, needle valve	VM26/25		B34/52 0.8, 1.0						
34. NEEDLE VALVE & SEAT ASSY.	VM26/26		VM34/39					or VM38/11-3.5	
35. RING, main jet	VM28/228		VM36/17					VM28/228	
36. MAIN JET			↔	↔ 4/042	↔				
37. PLATE, vent tube anchor	VM15/164		↔	↔ VM28/79	↔				
38. SCREW, float bowl	CW2=0416		CW2=0518		CW2=0516		CW2=0518		

# Super BN Carbs

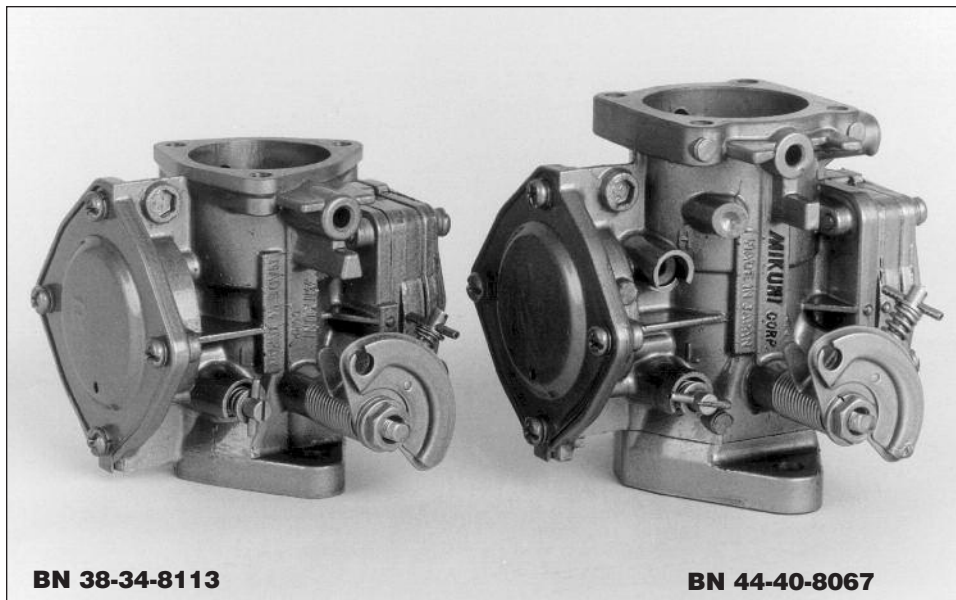

## SUPER BN SERIES SQUARE PUMP TYPE

Our High Performance Super BN Carburetors were specially designed to meet the needs of high horsepower racing watercraft. We have achieved greater air flow and fuel flow through extensive testing to provide maximum output. Special needle valves and springs give optimum pop-off with larger high and low speed jets. Super BN Series Carburetors feature improved air flow, higher capacity fuel pump, externally adjustable metering screws and replaceable fixed jets for easy high and low speed tuning.

**BN 38-34-8113**

**BN 44-40-8067**



**BN44-40-43**

- **BN34-28-8010** STANDARD 34mm Replacement
- **BN38-34-8113** Performance single 38mm to replace most standard BN or Super BN carbs. Features a Viton 2.0 needle valve, extended throttle shaft for dual or triple applications, #65 (slow) jet #107.5 main (high) jet, no butterfly choke, primer fitting and owners manual.
- **BN44-40-8067** Performance single 44mm for most sit-down models requiring larger jets. Features a Viton 2.5 needle valve, extended throttle shaft for dual or triple applications, #120 pilot (slow) jet, #140 main (high) jet, no butterfly choke, primer fitting and owners manual.
- **BN44-40-43** Original equipment replacement for Yamaha Superjet. Features standard stock jetting, butterfly choke, and 44mm main bore.



**BN44-40-8052**

- **BN44-40-8052** Performance single 44mm carb with extended throttle shaft to make dual kits. Designed to give maximum performance with a single carb. Features a Viton 2.3 needle valve, #100 pilot (slow) jet, #125 main (high) jet, primer type cold starter fitting (no butterfly choke), and angled fuel fittings and instruction manual.

## PRO RACING SUPER BN46 SERIES

The Super BN46 features a large 48mm intake tapering to a 42mm venturi and controlled by a 46mm butterfly valve. This carb comes to you ready to race.

Note: Bolt pattern is same as BN44, some manifold porting may be necessary for maximum air flow.

- **BN46-42-8002** Performance single 46mm carb with extended throttle shaft to make dual kits. Designed to give Pro Level Racing performance. Features a Viton 2.5 needle valve, #120 pilot (slow) jet, #150 main (high) jet, primer type cold starter fitting (no butterfly choke), angled fuel fittings and owners manual.



**BN46-42-8002**

## CURRENT BN I SERIES TYPE CARBURETORS

- **BN401-38-24** Original equipment on the 98 SeaDoo GTI, GTS, GS 167.5 hi-speed jet, 70 low-speed jet, 1.5 needle valve and 95g spring.
- **BN401-38-26** Original equipment on the 98 SeaDoo GSX, SPX -MAG
- **BN401-38-27** Original equipment on the 98 SeaDoo GSX, SPX -PTO 140/142.5 hi-spj jet, 67.5 low-spj jet, 1.5 needle valve and 95g spring.
- **BN461-42-B4** Original Dual Carbs on the 98 SeaDoo GSX, GTX -LTD 162.5 hi-spj jet, 77.5 low-spj jet, 2.0 needle valve and 95g spring.



# Accessories

## SUPER BN NEEDLE VALVE KITS

- **MK-BN38NV** Needle valve replacement kit for Super BN38, contains a 2.0 needle valve and 115 gram spring with approx. 32 lbs. pop off and an 80 gram spring for 21 lbs. pop-off. Instructions included.
- **MK-BN44 NV 1** Needle valve replacement kit for Super BN 44, contains a Viton 2.3 needle valve and 65 gram spring for 15 lbs. pop-off. Instructions included.
- **MK-BN44 NV 2** Needle valve replacement kit for High Performance Super BN 44 and 46, contains a 2.5 needle valve and 80 gram spring for 14 lbs. pop-off. Instructions included.



## BN / SBN / BNI CARB REBUILD KITS

All parts needed to rebuild your Super BN carb (Does not include needle valve, see needle valve part numbers). Exploded views of Rebuild Kits found on pages 26-28.

- **MK-BN38/44 SPR** 38/44/46mm rectangle pump body carb, and for 38/40mm "I" type.
- **MK-BN46I** 46mm "I" type.
- **MK-BN38/44** -38/44mm early style round body carb.
- **MK-BN44I-YAM** Yamaha G.P. PWC

## COUPLING KITS

- **MK-BN/001** Allows two carbs to be connected for dual carb setups.

## BN POP OFF PUMP

- **MK-BN PMP 30** lb. gauge gives accurate pop-off pressure readings. Our high pressure pump is durable and easy to use. This pump is a must for tuning your BN carb
- **MK-BN PMP 60** 60 lb. gauge and pump.
- **MK-BN PMP 100** 100 lb. gauge and pump allow for readings on many stock carbs with small needle valves and strong springs.



## UNIVERSAL JET BOXES

- **MK-BN/053** 36 Compartment Plastic Jet Box
- **KHS-024** 16 Compartment Plastic Jet Box

## TUNING COMPONENTS FOR SUPER BN Pilot (slow speed) Jets

N100.606-Sizes 50 through 150 in increments of 2.5.

## Main (high speed) Jets

N102.221-Sizes 50 through 200 in increments of 2.5.

## Needle Valve Assembly (solid needle, Viton)

786-35015-Sizes 1.5, 2.0, 2.3 and 2.5.

**Needle Valve Arm Springs** are available in different spring rates to vary your pop-off pressure.

Part Number	Rate	Color	Length
730-03030	65 grams	Shiny Silver	14.6mm
730-03033	80 grams	Black	14.6mm
730-03027-T	95 grams	Dull Silver	15.7mm
730-03027	115 grams	Platinum	16.7mm



## THROTTLE SHAFT REBUILD KITS

- **MK-BN038 TV** for SBN 38MM
- **MK-BN044 TV** for SBN 44MM
- **MK-BN046 TV** for SBN 46MM

Kit includes butterfly valve, shaft, seals, screws, instructions.

## SUPER BN OWNERS MANUAL

- **MK-BN/004** Provides details on carb tuning and service.

## BN REBUILD KIT Round Pump Carb Type MK-BN38/44

For BN34, BN38, & BN44 Round Pump Styles  
(Kit Includes Circled Items 1-15)

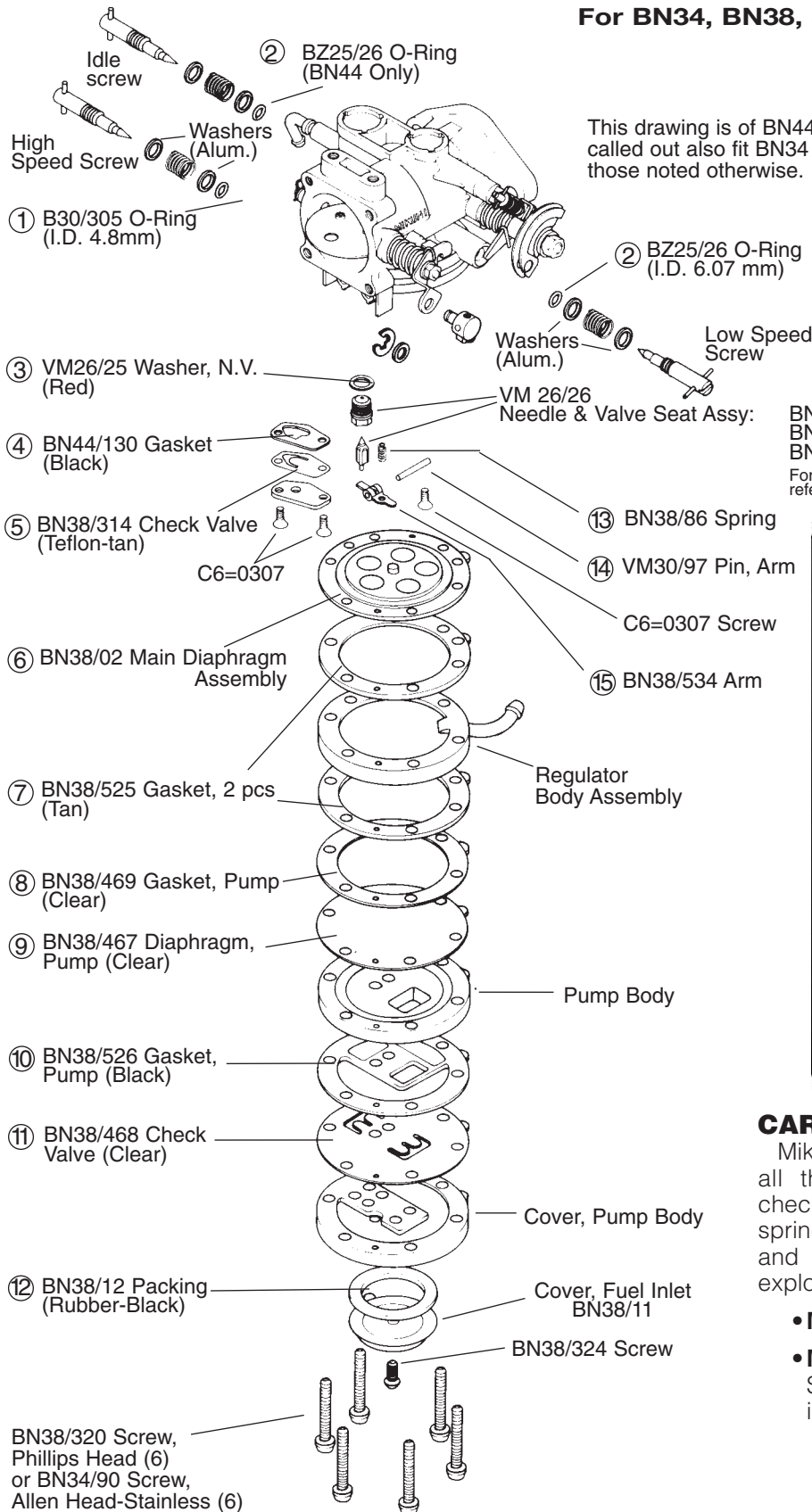

### CARBURETOR REBUILD KITS

Mikuni offers a rebuild kit that contains all the necessary O-rings, gaskets, check valves, diaphragms, washers and springs to completely rebuild your carb and make it run like new again. See exploded view for details of each kit.

- **MK-BN38/44SPR** for Super BN
- **MK-BN38/44** for Standard BN Series BN38 and BN44. (Does not include needle valve.)

## BN REBUILD KIT Square Carb Type

### MK-BN38/44 SPR

For SUPER BN38, BN44 and BN46, BN38I, BN40I Square Pump Styles

(Kit Includes Items 1-16 to Rebuild One Carb)

No.	Part No.	Description
1.	BN38/547	Gasket, Pump (2)
1a.	616-72001	O-ring, Pump body
2.	BN34/97	Diaphragm, Pump (Clear)
3.	BN34/124	Check Valve (2) (Clear)
4.	BN34/125	Grommet, Check Valve (2)
5.	BN34/100**	Diaphragm, Damper
5a.	BN34/129*	Diaphragm, Damper
6.	BN34/101**	Gasket, Damper
6a.	616-92007*	O-Ring
7.	BN44/146	Filter
8.	B30/305	O-Ring, Hi Speed
9.	MD12/16	O-Ring, Low Speed
10.	KV/10	O-Ring, Needle Valve
11.	BN34/123	Gasket, Valve Body
12.	BN34/107	Check Valve (Clear)
13.	730-03027	Spring, Arm (115 grams)
13a.	730-03030	Spring, Arm (65 grams)
13b.	730-03027T	Spring, Arm (95 grams)
14.	VM30/97	Pin, Arm
15.	BN38/534	Arm (Stainless)
16.	BN44/145	Diaphragm Assembly

## BN PARTS

(Items 17-43 for Reference Only, Not Included in Kit)

17.	BN34/120-30	Screw with 2 Washers, Stainless-30mm (4pcs.)
18.	BN34/95	Cover, Pump
19.	BN34/98** N/A	Body Assembly, Pump
19a.	BN34/128*	Body Assembly, Pump
20.	BN44/109**	Stop Screw, Idle
20a.	BN34/82*	Stop Screw, Idle
21.	BN38/39	Washer (Aluminum)
22.	BN38/341**	Spring, Idle
22a.	BN38/344*	Spring, Idle
23.	B26/03**	Cap
23a.	BN44/118*	Cap with Tab
24.	604-25017	Adjuster, Hi Speed, 38/44
24a.	BN 44/167	Adjuster, Hi Speed w/ Cross Bar, 38/44
25.	BN38/344	Spring, Hi Speed
26.	BN38/39	Washer, Hi Speed (Aluminum)
27.	BN38/172	Washer, Low Speed (Aluminum)
28.	BN38/343	Spring, Low Speed
29.	604-26008**	Adjuster, Low Speed, 44
29a.	BN38/477*	Adjuster, Low Speed (with Cross Bar), 38
29b.	BN38/166	Adjuster, Low Speed (with Cross Bar), 44
30.	BN44/188	Cap
31.	786-35015-size	Needle Valve Assembly (Viton)
32.	VM15/285	Spring Clip, N.V.
33.	BN34/117-GG	Plate, N.V. Retainer
34.	cw2-0307-G	Screw with Washer
35.	N100.606-size	Jet, Low Speed
36.	N102.221-size	Jet, High Speed
37.	BV15/121-05-GG	Screw
38.	BN34/108-GG	Plate, Valve
39.	BN44/165	Valve Body Assembly
40.	C5-0414-G	Screw (2pcs)
41.	C6-0308-G	Screw
42.	BN44/147	Cover (Stainless)
43.	MCWS-0512	Screw with Washer (4) (Stainless)
BN34/110	Spring	
45.	BN34/111	Bushing
46.	B40/55	Nut

Note: \*BN38 & later BN44 \*\*BN44 only

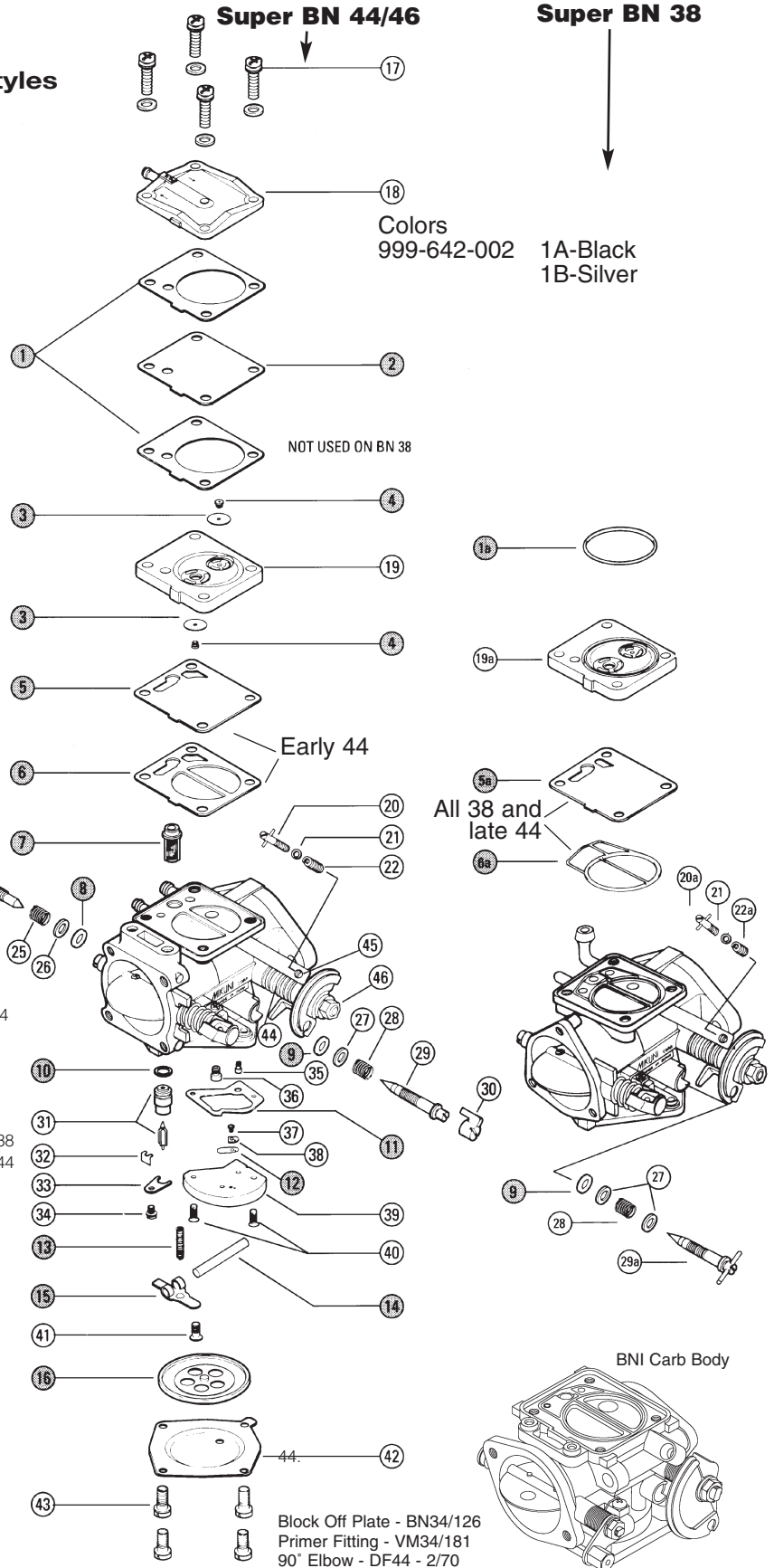

# BNI Rebuild Kits

## BN 46 I CARB REBUILD KIT MK-BN46I

No.	Part No.	Description
1.	BN46I/13	Gasket, Pump
2.	BN46I/14	Diaphragm, Pump (Clear)
3.	616-73002	O-Ring
4.	BN46I/11	Check Valve (2)
5.	BN34/125	Grommet (2)
6.	BN46I/34	Diaphragm, Damper
7.	BN46I/15	Diaphragm, Damper (Clear)
8.	616-73003	O-Ring
9.	BN44/146	Filter, Fuel
10.	B30/305	O-Ring, Hi Speed (2)
11.	MD12/16	O-Ring, Low Speed
12.	KV/10	O-Ring, Needle Valve
13.	BN34/123	Gasket, Valve Body
14.	BN34/107	Check Valve (Clear)
15.	VM30/97	Pin, Arm
16.	730-03034	Spring, Arm 95 gram
17.	BN38/534	Arm (Stainless)
18.	BN44/145	Diaphragm assy., Main

**NOTE: Rebuild Kit contains parts 1 through 18**

## BN46 I Replacement Parts

19.	BN34/120-35	Screw w/ washers (4)**
20.	BN46I/xx	Cover, Pump
21.	BN46I/49	Body Assy., Pump
22.	BN38I/40	Stop Screw, Idle
23.	BN38/39	Washer, Aluminum (3)
24.	BN38/344	Spring (2)
25.	999-904-006	Cap, Hi Speed Adjuster
26.	604-25017	Adjuster, Hi Speed
27.	BN38/172	Washer, Aluminum (2)
28.	BN38/343	Spring, Low Speed
29.	BN38/477	Adjuster, Low Speed
30.	N102.221-size	Jet, Hi Speed
31.	N100.606-size	Jet, Low Speed
32.	BV15/121-05-GG	Screw
33.	BN34/108-GG	Plate, Valve
34.	BN44/165	Valve Body Assy.
35.	C5=0414-G	Screw (2)
36.	786-35018-size	Needle Valve Assy.
37.	BN34/117-GG	Plate, Needle Valve rtnr
38.	CW2=0307-G	Screw w Washer
39.	C6=0308-G	Screw
40.	BN44/147	Cover (Stainless)
41.	C2S=0514	Screw (4)**
42.	BN40I/22	Diaphragm, Acclr. Pump

### \*\*Tightening Torque:

Part No. 19: 4.5 N/m (45 Kg/Cm)

Part No. 41: 3.5 N/m (35 Kg/Cm)

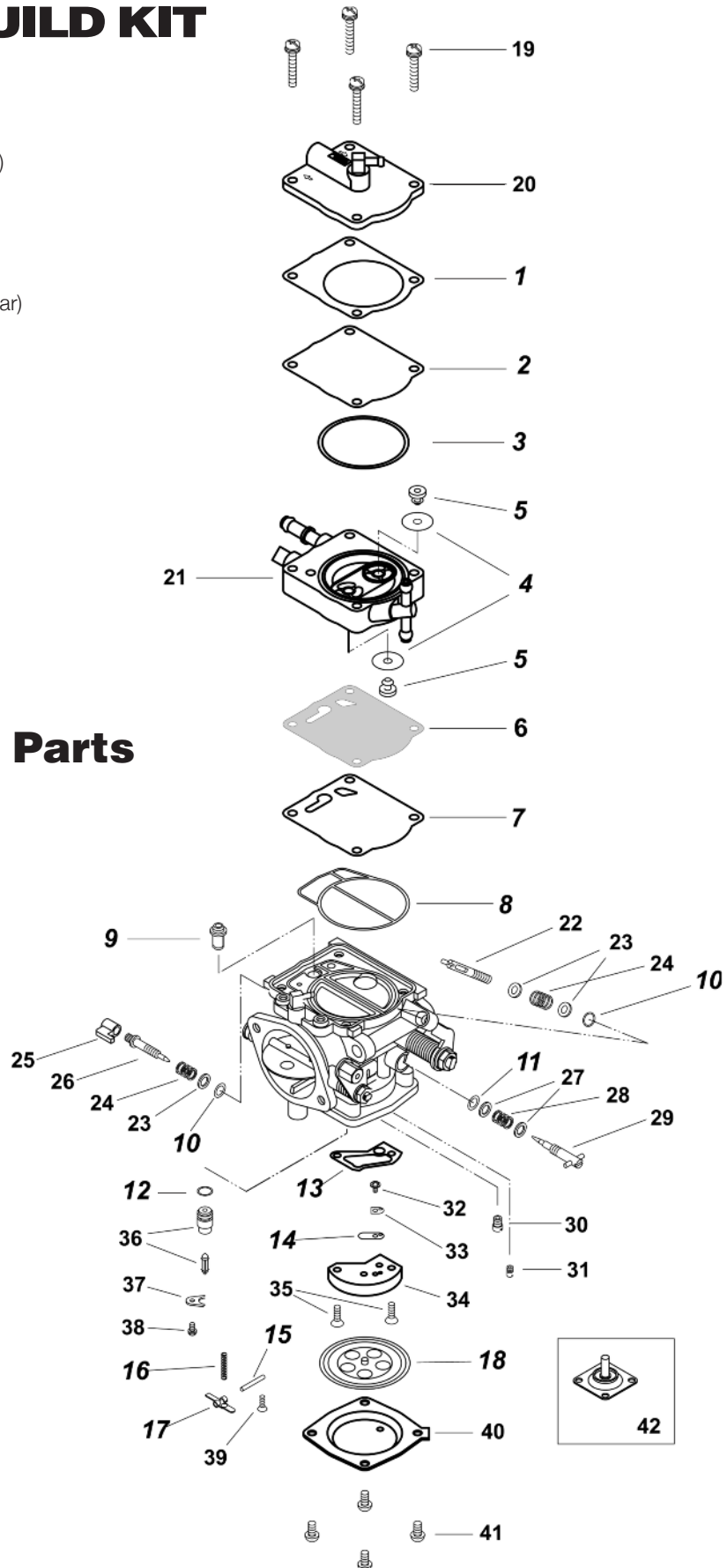

# Snowmobile

## POWER JET KIT MK-406

Power Jet Kits are used in 2-stroke engine applications to improve mid-range throttle response and add additional fuel to wide open throttle running conditions, especially with snowmobile clutches. Kit may be installed easily on Mikuni TM and VM Series Motorcycle and Snowmobile carburetors.

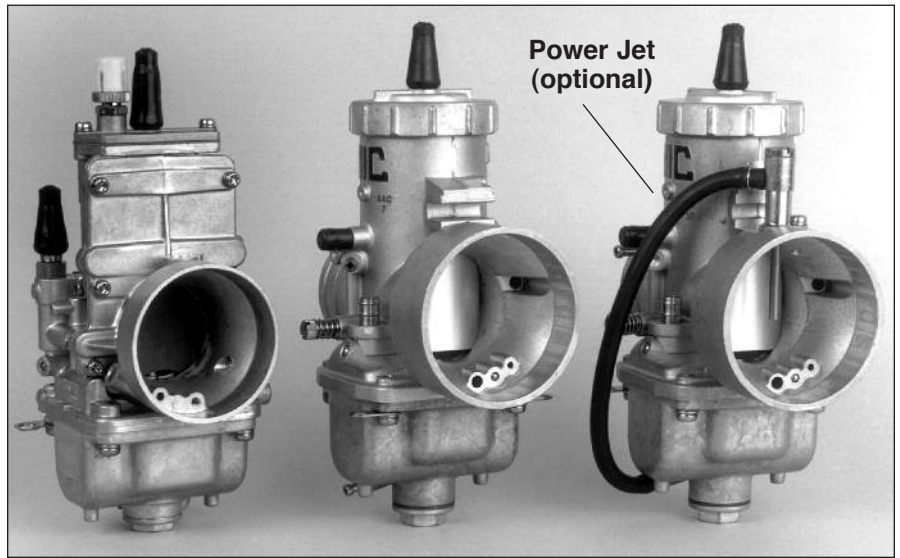

## Cable Starter Kit\* MK-412

For remote mounting of starter knob.

\*NOTE: Snowmobile Carburetors come with cable operated starter system.

## SNOWMOBILE CARBURETORS

Mikuni offers specially prepared carburetors designed to meet the unique demands of snowmobiles. Features are special throttle valve and needle valve designs better suited to colder, more dense air and constant throttle settings.

### SNOWMOBILE SINGLE CARBS

CARB NO.	SZ. MM.	MAIN JET (4/042)	PILOT JET (VM22/2/0)	NEEDLE JET (Series No.)	JET NEEDLE	THROTTLE VALVE (Part No.)	MAIN AIR JET (Part No.)	NEEDLE VALVE (Part No.)
VM30-164 STD	30	270	35	Q-O 159	6DH2	2.0	2.5 BODY	1.5
VM32-282	32	280	35	Q-O 159	6DH4	2.5	2.5 BODY	1.5
VM34-389	34	330	30	Q-O 159	6DH3	2.5	2.0 BS30/97	1.5
VM38-21	38	360	40	Q-O 166	6DH3	2.5 VM38/24	2.5 BODY	1.5 VM28/163
VM44-7	44	540	35	AA-5 224	7DH2	1.5 VM40/02 Aluminum	0.7 BS30/97	1.5 VM28/163
TM38-102 TM STYLE	38	340	25	Q-2 389	6FJ40	4.0 832-43011	2.5 BODY	1.5 832-43011
TM38-101 TMX STYLE	38	340	25	R-1 FIXED	6EJ12-57	4.0 999-832-014	2.5 BODY	1.8 786-36004-A

## RUBBER MOUNTING FLANGES

NOTE: Dimensions are millimeters.

PART NUMBER	8.5 MM BOLT HOLE	CARB BORE SIZE	CARB SPIGOT DIAMETER	FLANGE THROAT DEPTH	TYPICAL CARB SIZE
M-VM28-200K	60	30	35	28	26-28
990-842-046	57	30	37	23	26-28
990-842-007	75	34	40	32	30-34
M-VM34-200K	60	36	40	25	30-34
M-VM36-200K	70	40	43	25	36-40
I-VM38-200-1	75	40	43	28	36-40
M-VM40-200K	75	46	52	32	40-44
I-VM44-200-1	84	46	52	26	40-44
KHS-004	70-75	40	43	28	36-40
HS42/018-42K	70-75	42	45	25	42
HS42/062-42K	70-75	42	45	25	42
HS42/062-45K	70-75	45	48	25	45
HS42/018-45K	70-75	45	48	25	45
HS42/062-48K	70-78	48	51	25	48



# TUNING/JETTING

## Functional Range Effectiveness of Tuning Parts in Relation to the Throttle Valve Opening (Approximation)

NOTE: Power Jet Option equipped carbs will affect other tuning components.

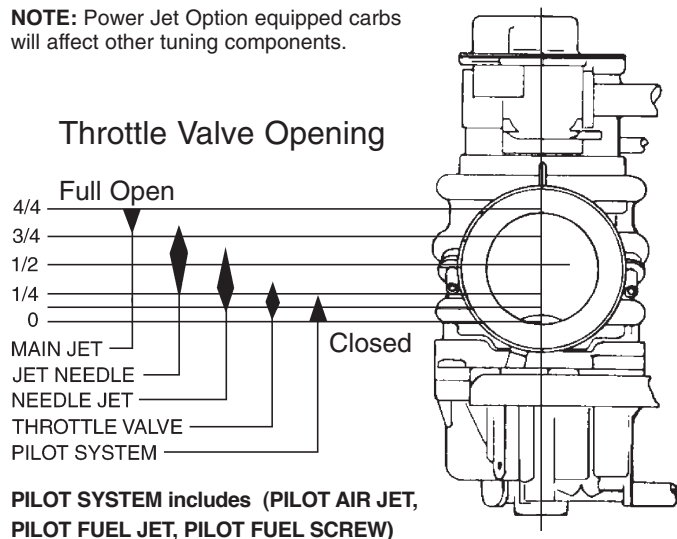





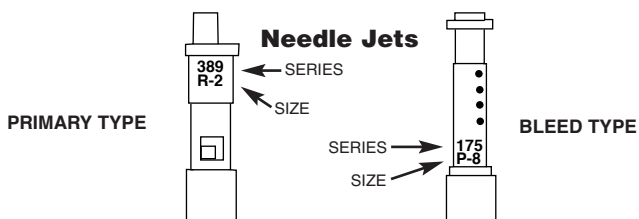



## Main Jets

Description	Part No.	Size Range
 Large Hex	4/042 (Fits VM, TM)	50 - 250 (Increments of 5) 250 - 250 (Increment 10) 500 - 640 (Increment 20) 650, 660, 680, 700, 710, 720
 Small Hex	M10/14	40 - 200 (Increment 5)
 Large Round	N100.604 (Fits RS and HS)	50 - 200 (Increment 2.5) 200 - 215 (Increment 5) 215 - 240 (Increment 10)
 Small Round	N102.221 (Fits SBN)	30 - 190 (Increment 2.5) 190 - 220 (Increment 5) 230, 240, 250
 Press - In	N208.099 Press-In OEM Application	110 - 180 (Increments of 2.5) Needs O-Ring #616-12001
 Large Thread	VM11/22	50 - 180 (Increments of 5)





**PARTS STAMPING** This marking on a jetting part is your quality assurance guarantee it is a genuine Mikuni component. **DO NOT ACCEPT SUBSTITUTES.**

## Pilot Jets

Description	Part No.	Size Range
 VM, TM, TMX	VM22/210 Fits VM, TM, TMX	10 - 60 (Increments of 2.5) 60 - 110 (Increment 5) 100 - 140 (Increment 10)
 RS, HSR	VM28/486 Fits RS, HS	10 - 70 (Increment 2.5)
 OEM TMX, BSR Rhino	N224.103 For CR, RM, YZ, KX	10 - 70 (Increment 2.5)
 OEM	N151.067 Non-Bleed, OEM Applications	30 - 60 (Increment 2.5)
 Bleed Type	BS30/96	30 - 60 (Increments of 2.5)
 B-Type Butterfly Carb	N101.043	30 - 100 (Increments of 2.5) 105 - 160 (Increments of 5)
 Super BN	N100.606 Low Speed Jet for SBN	30 - 160 (Increment 2.5)
 OEM Carbs, Banshee	M28/1001 Banshee OEM OEM Applications	15 - 70 (Increment 2.5)

## Air Jets

## Starter Jets

 <b>BS30/97</b> For Most Mikuni's .5 thru 2.0 Increments of .1	 <b>VM 17/1002</b> Controls enrichener on TM carburetors 20 thru 120 and 1.0, 1.5, 2.0
--	---

# Components

## Needle Jets

Carburetor	Part No.	Series	leaner Available Needle Jet Sizes richer
VM30 - VM36 Round Slide	VM34/05 (990-793-004 from P-0 up)	159	<b>N</b> -0, 4, 6, 8; <b>O</b> -0, 2, 4, 5, 6, 8; <b>P</b> -0, 2, 4, 5, 6, 8; <b>Q</b> -0, 2, 4, 5, 6, 8; <b>R</b> -0, 2, 4, 5, 6, 8.
VM38 Round Slide	VM34/17 (990-793-003 from P-0 up)	166	<b>N</b> -6, 8; <b>O</b> -0, 2, 4, 5, 6, 8; <b>P</b> -0, 2, 4, 5, 6, 8; <b>Q</b> -0, 2, 4, 5, 6, 8; <b>R</b> -0, 2, 4, 5, 6, 8.
VM28 - VM30 Small Body	VM30/38	169	<b>N</b> -0, 4, 6, 8; <b>O</b> -0, 2, 4, 5, 6, 8; <b>Q</b> -0, 2, 4, 5, 6, 8.
VM28 Round Slide TM28 Flat Slide	VM30/46	175	<b>O</b> -0, 2, 4, 5, 6, 8; <b>P</b> -0, 2, 4, 5, 6, 8.
VM30 - VM36 Round Slide Body	VM32/19	176	<b>O</b> -2, 4, 5, 6; <b>P</b> -2, 4, 5, 6, 8.
VM26 Round Slide Body	VM28/86	182	<b>N</b> -6; <b>O</b> -0, 2, 4, 5, 6, 8; <b>P</b> -0, 2.
VM40 - VM44 Round Slide Body	VM44/10	224	<b>Z</b> -0, 2, 4, 6, 8, 9; <b>AA</b> -0, 1, 2, 4, 5, 6, 8, 9; <b>BB</b> -0, 2, 3, 5, 9; <b>CC</b> -0, 5, 9.
Yamaha OEM	VM38/41	247	<b>O</b> -0, 2, 4, 6, 8; <b>P</b> -2, 4, 5, 6, 8; <b>Q</b> -0, 2, 4, 5, 6, 8; <b>R</b> -0, 2, 4, 6, 8.
TM32 - TM38 Flat Slide Body	785-24001	389	<b>O</b> -0, 2, 4, 6, 8; <b>P</b> -2, 4, 5, 6, 8; <b>Q</b> -0, 2, 4, 6, 8; <b>R</b> -0, 2, 4, 6, 8.
VM38 (Same 166 OEM) OEM Round Slide	785-23005	480	<b>N</b> -6, 8; <b>O</b> -0, 2, 4, 5, 6, 8, 9; <b>P</b> -0, 1, 2, 4, 5, 6, 7, 8, 9; <b>Q</b> -0, 2, 4, 5, 6, 8; <b>R</b> -0, 1, 2, 4, 5, 6, 8.
RS34 - RS40 HS40 - TM36	784-13002	568	<b>Q</b> -6, 8; <b>P</b> -0, 2, 4, 5, 6, 8; <b>Y</b> -0, 2, 4, 5, 6, 8; <b>Z</b> -0, 2, 4, 5, 6; <b>BB</b> -0.
TMX OEM Series Flat Slide Body	784-13005	633	<b>S</b> -4, 6, 7, 8; <b>T</b> -0.
TM33 Flat Slide Body	784-241111	640	<b>P</b> -4, 6, 8; <b>Q</b> -0, 2.
HSR42-48 Roller Flat Slide	784-430000	723	<b>Y</b> -2, 4, 6, 8; <b>Z</b> -0.
TMX-X OEM Series	784-410002	914	<b>S</b> -2, 4, 7, 8, 9; <b>T</b> -0.
TM24 Flat Slide	784-21005	454	<b>P</b> -8, <b>Q</b> -0, <b>Q</b> -8.

## Needle & Seat Assemblies

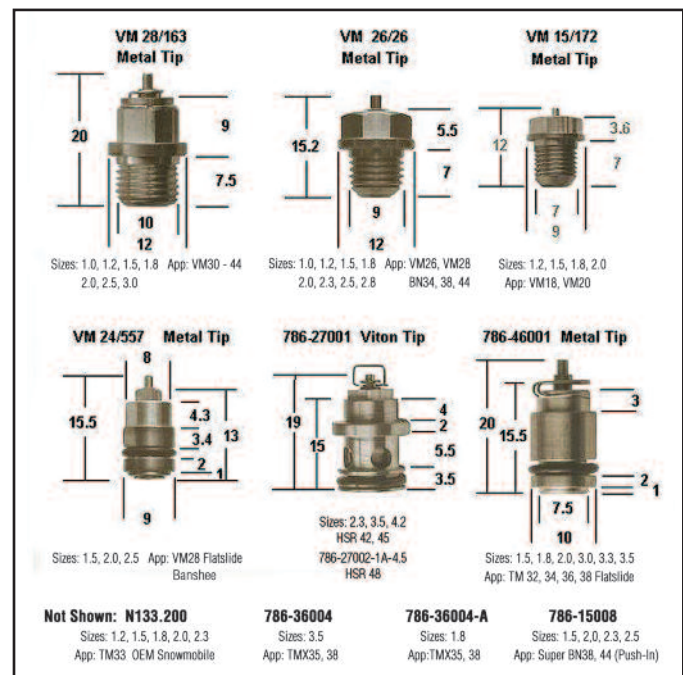
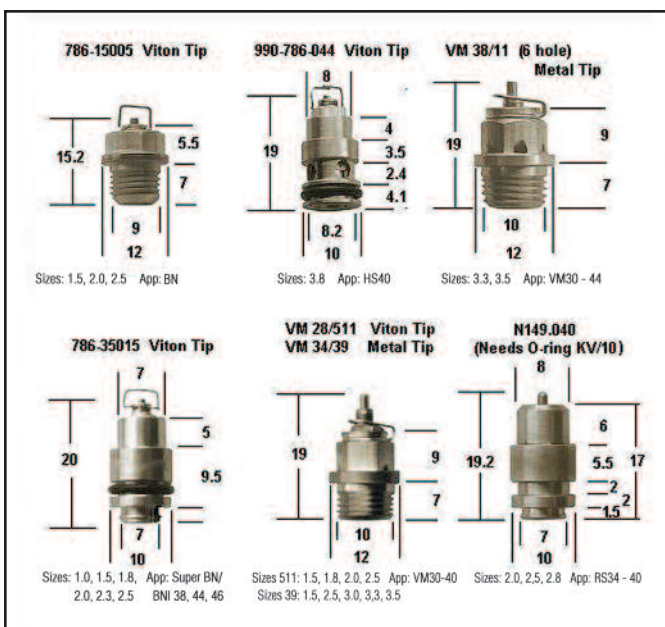

# TUNING/JETTING

The Jet Needle controls the fuel mixture in the mid-range (1/4-3/4) throttle position. The taper of the needle determines the amount of fuel. For example: the thinner the diameter of the needle, the more fuel will be drawn. The thicker the diameter of the needle, the less fuel can be drawn.

## TWO TYPES OF NEEDLES

### Single Taper Type



### Double Taper Type

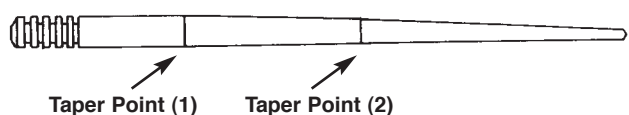

## NEEDLE TAPER DIAMETER DIMENSION CHART

D-1 through D-5 indicates diameter (mm) at each point.

	A	B	D-1	D-2	D-3	D-4	D-5
4E1	50.3	28.0	2.515	2.515	2.345	2.127	1.924
4J13	50.2	24.0	2.513	2.513	2.230	1.800	1.400
4L6	50.3	24.5	2.515	2.515	2.178	1.660	1.190
4J11	41.5	21.3	2.512	2.506	2.188	1.776	

D-1 through D-6 indicates diameter (mm) at each point.

	A	B	D-1	D-2	D-3	D-4	D-5	D-6
5F3	58.0	27.4	2.519	2.519	2.419	2.135	1.863	
5EJ11	60.3	28.5	2.515	2.515	2.515	2.241	1.839	1.420
5FL11	60.3	28.2	2.518	2.518	2.438	2.175	1.740	1.256
5FL14	58.0	28.0	2.520	1.520	2.440	2.170	1.735	
5FL7	58.0	28.0	2.518	2.518	2.440	2.170	2.170	1.735
5DP7	57.6	26.4	2.512	2.512	2.440	2.259	1.580	
5J6	58.0	27.5	2.518	2.518	2.340	1.890	1.450	
5L1	58.0	27.0	2.518	2.518	2.330	1.811	1.297	
5J9	58.0	27.0	2.522	2.520	1.432	1.996	1.505	

D-1 through D-6 indicates diameter (mm) at each point.

	A	B	C	D-1	D-2	D-3	D-4	D-5	D-6
6F5	62.3	38.1	19.0	2.515	2.456	2.454	2.364	2.098	1.840
6F4	62.3	32.0	19.4	2.515	2.442	2.436	2.206	1.939	1.678
6F8	62.3	34.0	21.5	2.512	2.512	2.386	2.214	1.945	1.688
6F16	64.6	31.2	18.4	2.520	2.404	2.400	2.201	1.941	1.679

## SERIES TYPE

## APPLICATION

#4	All 18mm Carburetors 22mm and 24mm Flange
#5	26mm-32mm Spigot 28mm-34mm Flange
#6	30mm-38mm Spigot
#7	40mm and 44mm Spigot
#8	HSR 42/45 Carbs
#9	RS and HS Carbs

D-1 through D-6 indicates diameter (mm) at each point.

	A	B	D-1	D-2	D-3	D-4	D-5	D-6
6DH2	62.3	28.0	2.511	2.511	2.466	2.295	2.000	1.660
6F9	62.3	28.9	2.516	2.516	2.475	2.210	1.949	1.678
6CF1	61.5	29.5	2.512	2.512	2.429	2.240	1.974	1.710
6FJ6	62.3	35.2	2.505	2.505	2.505	2.376	2.040	1.606
6DH3	62.3	22.0	2.512	2.512	2.458	2.286	1.948	1.607
6L1	62.3	37.0	2.512	2.512	2.512	2.335	1.826	1.313
6DP17	62.3	32.1	2.518	2.518	2.518	2.372	1.834	1.141
6N1	62.3	37.0	2.514	2.514	2.514	2.278	1.672	1.058
6DP1	62.3	28.9	2.511	2.511	2.476	2.312	1.748	1.075
6DH4	62.3	25.5	2.520	2.520	2.440	2.258	1.915	1.575
6DH7	62.2	28.5	2.516	2.516	2.505	2.316	2.009	1.688
6DH8	62.2	20.3	2.538	2.538	2.436	2.208	1.827	1.497
6FL14	62.1	26.7	2.538	2.538	2.538	2.233	1.649	1.218
6F15	62.2	19.8	2.535	2.538	2.461	2.208	1.979	1.649
6DP10	62.4	26.5	2.51	2.51	2.44	2.26	1.56	.89
6F13	64.2	32.8	2.50	2.46	2.46	2.24	1.97	1.70
6DJ30	64.7	26.3	2.51	2.51	2.45	2.09	1.66	1.24

D-1 through D-7 indicates diameter (mm) at each point.

	A	B	D-1	D-2	D-3	D-4	D-5	D-6	D-7
7DH5	72.2	27.4	2.98	2.98	2.94	2.78	2.44	2.08	1.72
7F7	72.3	33.1	2.99	2.99	2.99	2.80	2.54	2.28	2.02
7F6	72.3	29.0	3.00	3.00	2.95	2.68	2.41	2.14	1.87
7DH3	72.5	28.1	2.98	2.98	2.96	2.80	2.47	2.11	1.76
7DH2	75.3	31.6	2.99	2.99	2.99	2.84	2.66	2.27	1.92

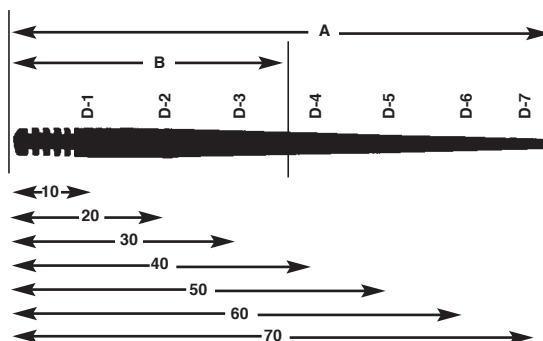



# Components



JET NEEDLE NUMBER	APPLICATIONS	NEEDLE DIAMETER BEFORE TAPER (mm)	AIR FUEL RATIO
6FJ41 6FM46 6FJ40 6DP04	TM38 FLATSLIDE ↕	2.522 2.522 2.522 2.515	LEANER ↕ RICHER
6EJ12-60 ↕ 59 58 57 56 55 54 ↕ 53	Early TMX38 FLATSLIDE ↕	2.60 2.59 2.58 2.57 2.56 2.55 2.54 2.53	LEANER ↕ RICHER
6EN11-58 ↕ 57 56 55 54 53 ↕ 52	Early TMX35 FLATSLIDE ↕	2.58 2.57 2.56 2.55 2.54 2.53 2.52	LEANER ↕ RICHER
9DZH01 (STD) 9DZH03 9DZH04	RS34-36 SMOOTHBORE	2.50 2.49 2.48	LEANER ↓ RICHER
9CHY03 (STD) 9CHY05 9CHY06	RS38-40 SMOOTHBORE	2.99 2.98 2.97	LEANER ↓ RICHER
8DDY01-98 ↕ 97 (STD) 96 ↕ 95	HSR42 ↕	2.98 2.97 2.96 2.95	LEANER ↕ RICHER
8CFY02-98 ↕ 97 (STD) 96 ↕ 95	HSR45 ↕	2.98 2.97 2.96 2.95	LEANER ↕ RICHER
J8-8CFY15-98 ↕ 97 (STD) 96 ↕ 95	HSR48 ↕	2.98 2.97 2.96 2.95	LEANER ↕ RICHER

## BSR Type Carburetor Rebuild Kits

Mikuni BSR Carbs are OEM on many Japanese ATVs, etc.

- MK-BSR33** BSR 33mm Rebuild Kit
- MK-BSR42** BSR 44mm Rebuild Kit
- MK-405** BSR 33/42mm Air Cut-Off Valve Rebuild Kit

## THROTTLE SLIDES

**NOTE:** Brass slides are chrome plated.  
Aluminum slides are anodized, Xylan or Nickel-plated.



### POCKET TUNER

A pocket-size slide calculator which determines required jetting changes in Mikuni carburetors due to ambient temperature, altitude, or both. It also provides a guide for determining rich or lean carburetor conditions. The Pocket Tuner is applicable to both single and multi-carburetor applications on two stroke and four-stroke engines. **MK-550-TNR**

PART Number	CARB Application	SLIDE Material	IDLE SCREW Location	GUIDE PIN Groove Width	CUT-A-WAY Available
VM28/56	26-28 Spigot	Brass	Left	2.05mm	1.5, 2.0
VM30/176	30 Small Body	Brass	Left	2.05	1.0 thru 3.5
VM32/65	30, 32, 34 Spigot	Brass	Right	2.60	1.5 thru 3.5
VM34/110	30, 32, 34 Spigot	Brass	Left	2.60	1.0 thru 3.5
VM36/36	36 Spigot	Brass	Left	3.05	1.5 thru 3.5
VM36/39	36 Spigot	Brass	Right	3.05	3.0, 3.5
VM38/24	38 Spigot	Brass	Right	3.05	1.0 thru 3.5
VM38/52	38 Spigot	Brass	Left	3.05	1.5 thru 3.0
VM40/02	40, 44 Spigot	Alum.	Left	3.05	0.5 thru 4.0
VM44/23	40, 44 Spigot	Brass	Left	3.05	1.5 thru 4.0
832-39012	TM32-34	Alum.	Left		4.0
832-41018	TMX38	Brass	Left		5.0
832-43002	TM36, 38-1,3	Alum.	Left		1.5 thru 5.0
832-43011	TM38-85, 86	Alum.	Left		2.5 thru 4.5
999-832-014	TMX35, 38	Alum.	Left		2.5 thru 6.0
999-832-017-IH	TMS38,125	Alum.	Left		None

# Fuel Pumps

## PULSE FUEL PUMPS

Mikuni Pulse Fuel Pumps employ an engine's fluctuating engine crankcase pressure to pump fuel from a remote fuel tank to an engine's carburetor(s). Applications include personal watercraft and snowmobiles.

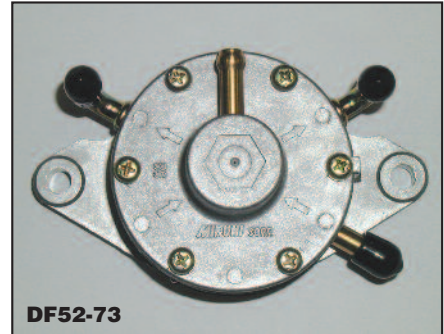
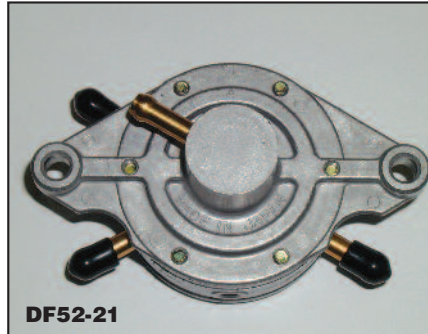

Part Number	Number of Outlets	Style	Mounting	Flow Rate LITERS/HR
DF44-227	1	RECTANGLE	FLUSH	14
DF52-176	2	ROUND	BRACKET	35
DF52-73	2	ROUND	FLUSH	35
DF52-92	3	ROUND	FLUSH	35
DF52-136	2	SQUARE	FLUSH	31
DF62-702	2	PENTAGON	FLUSH	65

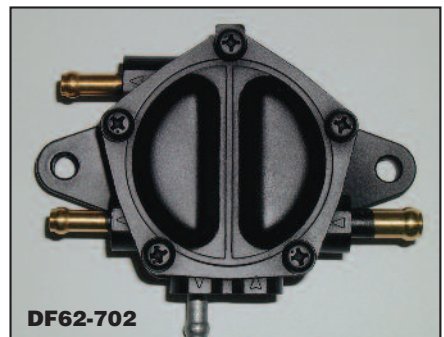
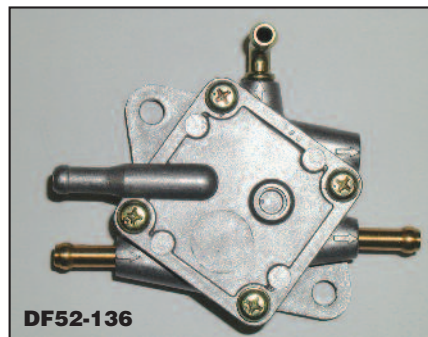
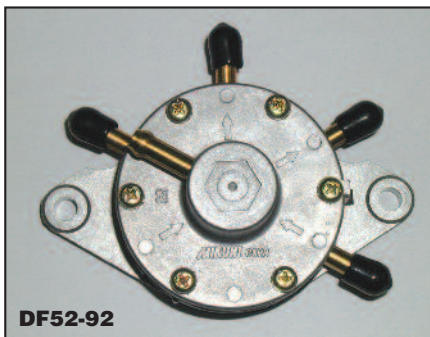

## FUEL PUMP REBUILD KITS



PART NUMBER	CONTENTS	DESCRIPTION	QUANTITY	REMARKS
<b>MK-DF44</b>	CW2=0416	SCREW	4	W/WASHER
	DF44-201/03	GASKET	1	FIBER
	DF44-201/04	DIAPHRAGM	1	CLEAR
	DF44-201/05	MEMBRANE	1	THIN RUBBER
<b>MK-DF52</b> (Except DF52-136)	DF52/105	GASKET	1	THICK FIBER
	DF52-48/10	DIAPHRAGM	2	TRANSPARENT FILM
	DF52-48/05	GASKET	1	THIN RUBBER
	DF52/113	GASKET	1	THIN RUBBER
	DF52/36A	GASKET	1	THICK FIBER
	DF52/27A	VALVE	2	CLEAR
	DF44/26	GROMMET	2	BLACK
<b>MK-DF62</b>	DF62-601/03	GASKET	2	PAPER GASKET
	DF62-601/04	DIAPHRAGM	2	CLEAR
	DF62-701/03	GASKET	2	PAPER GASKET
	DF62-701/05	CHECK VALVE	2	CLEAR GROMMET
	<b>MK-DF52-531</b>	Yamaha Rhino Fuel Pump Rebuild Kit	1	