



---

# ***GR8-1200 OEM***

**Multitasking Battery and  
Electrical Diagnostic Station**

---

# ***INSTRUCTION MANUAL***



# Safety Guidelines

## 1 General Safety Precautions

- 1. IMPORTANT SAFETY INSTRUCTIONS. **IT IS OF UTMOST IMPORTANCE THAT BEFORE USING YOUR CHARGER, YOU READ THIS MANUAL AND FOLLOW THE SAFETY AND OPERATING INSTRUCTIONS EXACTLY. SAVE THESE INSTRUCTIONS.**

<b> WARNING</b>
<b>Risk of explosive gases</b>
Batteries generate explosive gases during normal operation, and when discharged or charged.

- 1.1 To reduce risk of battery explosion, follow these safety instructions and those published by the battery manufacturer and the manufacturer of any equipment you intend to use in the vicinity of a battery. Review cautionary marking on these products and on the engine, and on the vehicle or equipment containing the battery.

<b> WARNING</b>
<b>Charging a non-rechargeable battery may cause the battery to burst.</b>
To reduce the risk of injury, only charge rechargeable lead-acid type batteries including maintenance-free, low-maintenance, or deep-cycle batteries.

If you are uncertain as to the type of battery you are attempting to charge, or the correct procedure for checking the battery's state of charge, contact the seller or battery manufacturer.

- 1.2 Use of an attachment not recommended or sold by the battery charger manufacturer may result in a risk of fire, electric shock, or injury to persons.
- 1.3 To reduce risk of damage to the electric plug and cord, pull by the plug rather than by the cord when disconnecting the charger.
- 1.4 Position the AC and DC leads to avoid tripping over them and to prevent damage by hood, doors, or moving engine parts; protect from heat, oil, and sharp edges.
- 1.5 Do not operate the charger if it has received a sharp blow, been dropped or otherwise damaged in any way; take it to a qualified service center.
- 1.6 Do not disassemble charger; take it to a qualified service center when repair is required. Incorrect reassembly may result in a risk of electric shock or fire.
- 1.7 To reduce risk of electric shock, unplug the charger from the AC outlet before attempting any maintenance or cleaning. Turning off the controls will not reduce this risk.

<b> WARNING</b>
<b>Remove marine "boat" batteries and charge them on shore.</b>
Charging marine batteries on-board requires specially designed equipment for marine use.

- 1.8 Connect and disconnect the battery leads only when the AC supply cord is disconnected.
- 1.9 Do not overcharge the battery. (See sections 3 and 10 in the safety instructions)
- 1.10 Charge the battery in a dry, well-ventilated area.
- 1.11 Never place articles on or around the charger, or locate the charger in a way that will restrict the flow of cooling air through the cabinet.
- 1.12 An extension cord should not be used unless absolutely necessary. (See paragraph 4.3.)
- 1.13 Have a damaged cord or plug replaced immediately.
- 1.14 Do not expose the charger to rain or snow.

## 2 Personal Precautions

- 2.1 Always have someone within range of your voice, or close enough to come to your aid, when working around lead acid batteries.
- 2.2 Have plenty of fresh water and soap nearby in case battery acid contacts skin, clothing or eyes.
- 2.3 Wear complete eye protection, clothing protection, and wear rubber soled shoes. Place damp cloth over battery to protect against acid spray. When ground is very wet or covered with snow, wear rubber boots. Avoid touching eyes while working near battery.
- 2.4 If battery acid contacts skin or clothing, wash immediately with soap and water. If acid enters the eye, immediately flush with cold running water for at least 10 minutes, and seek medical attention.
- 2.5 NEVER smoke or allow a spark or flame in vicinity of a battery or engine.
- 2.6 Be extra cautious to reduce risk of dropping a metal tool onto the battery. It might spark or short circuit the battery or other electrical part that may cause an explosion.
- 2.7 Before working with a lead-acid battery, remove personal metal items such as rings, bracelets, necklaces, watches, etc. A lead-acid battery can produce a short circuit current high enough to weld such items causing a severe burn.

**⚠ WARNING**

**Non-rechargeable batteries may burst when charging causing personal injury and damage.**

Only charge rechargeable lead-acid maintenance-free, low-maintenance or deep-cycle batteries.

The charger is not intended to supply power to a low-voltage electrical system other than applications using rechargeable, lead-acid type batteries. Do not use the battery charger for charging dry-cell batteries commonly used with home appliances. These batteries may burst and cause personal injury and property damage.

2.9 **NEVER** charge a frozen battery; thaw it out first.

### 3 Preparing To Charge The Battery

- 3.1 If it is necessary to remove the battery from vehicle to charge it, always remove the grounded terminal from the battery first. Make sure all accessories in the vehicle are off, so as not to cause an arc.
- 3.2 Be sure the area around the battery is well ventilated while the battery is being charged. Gas can be forcefully blown away by using a piece of cardboard or other nonmetallic material as a fan.
- 3.3 Clean the battery terminals. Be careful to keep corrosion from coming into contact with your eyes.
- 3.4 Add distilled water in each cell until the battery acid reaches the level specified by the manufacturer. This helps purge excessive gas from the cells. Do not overfill. For a battery without caps, carefully follow the manufacturer's recharging instructions
- 3.5 Study all battery manufacturer's specific precautions such as removing or not removing cell caps while charging and recommended rates of charge.
- 3.6 Determine the voltage of the battery by referring to the car owner's manual and make sure that the output voltage selector switch is set at the correct voltage. If the charger has an adjustable charge rate, charge the battery initially at lowest rate. If the charger has only one voltage, verify that the battery voltage matches the voltage of charger.

For a charger not having an output voltage selector switch, determine the voltage of the battery by referring to car owner's manual and make sure it matches the output rating of the battery charger.

### 4. Grounding & Power Cord Connections

- 4.1 The charger must be grounded to reduce risk of electric shock. The charger is equipped with an electric cord having an equipment grounding conductor and a grounding plug. The plug must be plugged into an outlet that is properly installed and grounded in accordance with all lo-

cal codes and ordinances.

**⚠ DANGER**

**Hazardous voltage.**  
**An improper connection can result in electric shock**

To avoid electrical shock or burn, never alter the charger's original AC cord and plug. Disconnect plug from outlet when charger is idle.

**IF THE PLUG DOES NOT FIT THE OUTLET, HAVE A PROPER OUTLET INSTALLED BY A QUALIFIED ELECTRICIAN.**

- 4.2 This battery charger is for use on a nominal 120-volt circuit and has a grounding plug that looks like the plug illustrated in *Figure A*. A temporary adapter, which looks like the adapter illustrated in *Figures B* and *C*, may be used to connect this plug to a two-pole receptacle as shown in *Figure B*, if a properly grounded outlet is not available. The temporary adapter should be used only until a properly grounded outlet can be installed by a qualified electrician.

**⚠ DANGER**

**Hazardous voltage.**  
**An improper connection can result in electric shock**

Before using an adapter be certain the center screw of the outlet plate is grounded. The rigid ear or lug extending from the adapter must be connected to a properly grounded outlet. Make certain it is grounded. If necessary, replace the original screw that secures the adapter ear or lug to the cover plate and make the ground connection to the grounded outlet.

**USE OF AN ADAPTER IS NOT ALLOWED IN CANADA. IF A GROUNDING-TYPE RECEPTACLE IS NOT AVAILABLE, DO NOT USE THIS APPLIANCE UNTIL THE PROPER OUTLET IS INSTALLED BY A QUALIFIED ELECTRICIAN.**

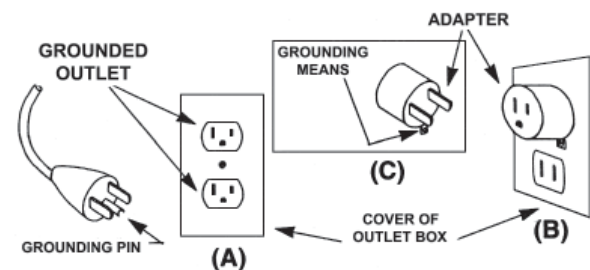

- 4.3 An extension cord should not be used unless absolutely necessary. Use of an improper extension cord could result in a risk of fire and electric shock. If an extension cord must be used, make sure:
  - a. that the pins on plugs of the extension cord are the same number, size, and shape as those of the plug on the charger;
  - b. that the extension cord is properly wired and in good electrical condition;
  - c. that the wire size is large enough for the AC ampere rating of charger as specified in the following table.

Table 1: Recommended minimum AWG* size for extension cords for battery chargers					
AC input rating amperes		AWG* size of cord			
Equal or greater than:	But less than:	Length of cord, feet (m)			
		25 (7.6)	50 (15.2)	100 (30.5)	150 (45.6)
8	10	18	14	12	10
10	12	16	14	10	8
12	14	16	12	10	8
14	16	16	12	10	8
16	18	14	12	8	8

\*American Wire Gauge

### 5. Charger Location

- 5.1 Locate the charger as far away from the battery as the charger cables permit.
- 5.2 Never place the charger directly above the battery being charged; gases from the battery will corrode and damage the charger.
- 5.3 Never allow battery acid to drip on the charger when taking gravity readings or filling a battery.
- 5.4 Operate the charger only in a well-ventilated area that is free of dangerous vapors.
- 5.5 Store the charger in safe, dry location and maintain it in perfect condition.
- 5.6 Do not set the battery on top of the charger or where its acid might drip onto the charger.

### 6. DC Connection Precautions

- 6.1 All switches should be set in the OFF position and AC cord should be DISCONNECTED from electrical outlet before you connect and disconnect the charger clamps. Never allow the clamps to touch each other.
- 6.2 When attaching the charger clamps, be certain to make the best possible mechanical as well as electrical connection. This will tend to prevent the clamps from slipping off the connections, avoid dangerous sparking, and assure safer and more efficient charging. The clamps should be kept clean.

DANGER

**Hazardous voltage.**  
Can cause death or serious personal injury.

Setting the switches to "OFF" does not always disconnect the charger electrical circuit from the AC power cord or the DC charger clamps.

### 7. Installing The Battery

WARNING

**Risk of explosive gases**

A spark near the battery may cause a battery explosion. Follow these steps when the battery is installed in the vehicle to reduce the risk of explosion.

- 7.1 Before working on the vehicle, firmly apply the emergency brake and place the gear shift to NEUTRAL—shift an automatic transmission to PARK.
- 7.2 Locate the charger as far away from the battery as the charger cords permit and position the AC and DC cords to avoid stepping on or tripping over them and to prevent damage by hood, doors, or moving engine parts.
- 7.3 Stay clear of fan blades, belts, pulleys, and any other parts that can cause physical injury.
- 7.4 Turn **OFF** all vehicle loads, including door lights, and correct any defects in the vehicle's electrical system that may have caused low battery.
- 7.5 Check the polarity of the battery posts. The **POSITIVE (POS., P, +)** post usually has a larger diameter than the **NEGATIVE (NEG., N, -)** post.
- 7.6 Determine which post of the battery is grounded (connected) to the chassis. If the negative post is grounded (as in most vehicles), see paragraph 7.7. If the positive post is grounded, see paragraph 7.8.
- 7.7 For a negative-grounded vehicle, first connect the **POSITIVE (RED)** clamp from the charger to the **POSITIVE (POS., P, +)** ungrounded post of the battery. Then connect the **NEGATIVE (BLACK)** clamp to the **NEGATIVE (NEG., N, -)** post of the battery. Do not connect the clamp to the carburetor, fuel lines, or sheet-metal body parts. When disconnecting the charger, turn all switches to **OFF**, disconnect the AC cord, remove the clamp from the **NEGATIVE** battery terminal, and then remove the clamp from the **POSITIVE** battery terminal.

- 7.8 For positive-grounded vehicle, connect the **NEGATIVE (BLACK)** clamp from the charger to the **NEGATIVE (NEG., N, -)** ungrounded post of battery. Then connect the **POSITIVE (RED)** clamp to the **POSITIVE (POS., P, +)** post of the battery. Do not connect clamp to carburetor, fuel lines, or sheet-metal body parts.

When disconnecting the charger, turn the switches to **OFF**, disconnect the AC cord, remove the clamp from the **POSITIVE** battery terminal, and then remove the clamp from the **NEGATIVE** battery terminal.

**CAUTION: WHEN POSITIVE (+) POST OF VEHICLE BATTERY IS GROUNDED, DOUBLE CHECK POLARITY.**

8. If it is necessary to remove the battery from the vehicle or equipment, always remove the grounded terminal from the battery first.

**⚠ WARNING**

**Risk of explosive gases**

A spark near the battery may cause a battery explosion. Follow these steps when the battery is installed in the vehicle to reduce the risk of explosion.

- 8.1 Check the polarity of battery posts. **POSITIVE (POS., P, +)** post usually has larger diameter than **NEGATIVE (NEG., N, -)** post.
- 8.2 Attach at least a 60 cm (24-inch), 6-gauge insulated battery cable to the negative (-) battery terminal.
- 8.3 Connect the **POSITIVE (RED)** charger clamp to the **POSITIVE (POS., P, +)** post of battery.
- 8.4 Position yourself and the free end of cable as far away from the battery as possible—do not face the battery when making the final connection—then connect the **NEGATIVE (BLACK)** charger clamp to the free end of the cable.
- 8.5 When disconnecting the charger, always do so in the reverse sequence of the connecting procedure; break the first connection while staying as far away from the battery as practical.
- 8.6 **MARINE “BOAT” BATTERIES MUST BE REMOVED AND CHARGED ON SHORE. TO SAFELY CHARGE THEM ON BOARD REQUIRES EQUIPMENT ESPECIALLY DESIGNED FOR MARINE USE.**

**WARNING:** Make sure all vehicle loads are **OFF** to prevent a possible arc.

## Chapter 1: Before You Begin



### Safety Reminder

For safe, efficient, and accurate charging and testing, review the safety and operating instructions in this manual before using the analyzer. In addition, follow all manufacturers' instructions and BCI (Battery Council International) safety recommendations.



### Safety Precautions



Inspect the battery for damages and check the electrolyte level. If the electrolyte level is too low, replenish it and fully charge the battery. Always use the necessary safety precautions when working with batteries to prevent severe injury or death. Follow all manufacturers' instructions and BCI (Battery Council International) safety recommendations, which include the following precautions:

- ▶▶▶▶ **DANGER—RISK OF EXPLOSIVE GASES:** Batteries can produce a highly explosive mix of hydrogen gas and oxygen, even when the battery is not in operation. Always work in a well-ventilated area. Never smoke or allow a spark or flame in the vicinity of a battery.
- ▶▶▶▶ **WARNING—REQUIRED BY CALIFORNIA PROP. 65:** Battery posts, terminals, and related accessories contain lead and lead compounds, chemicals known to the state of California to cause cancer and birth defects or other reproductive harm. Wash hands after handling.
- ▶▶▶▶ Battery acid is highly corrosive. If acid enters your eyes, immediately flush them thoroughly with cold running water for at least 15 minutes and seek medical attention. If battery acid gets on your skin or clothing, wash immediately with a mixture of water and baking soda.
- ▶▶▶▶ Always wear proper safety glasses or face shield when working with or around batteries.
- ▶▶▶▶ Keep hair, hands, and clothing as well as the analyzer cords and cables away from moving engine parts.
- ▶▶▶▶ Remove any jewelry or watches before you start servicing the battery.
- ▶▶▶▶ Use caution when working with metallic tools to prevent sparks or short circuits.
- ▶▶▶▶ Never lean over a battery when testing, charging, or jump starting.
- ▶▶▶▶ Never charge a frozen battery. Gases may form, cracking the case, and spray out battery acid.

## Conventions Used in This Manual

To help you learn how to use your GR8, the manual uses these symbols and typographical conventions:

**Table 2: Symbols And Typographical Conventions**

Convention	Description
	The safety symbol indicates instructions for avoiding hazardous conditions and personal injury.
<b>CAUTION</b>	The word <b>CAUTION</b> indicates instructions for avoiding equipment damage.
	The wrench symbol indicates procedural notes and helpful information.
<b>UP ARROW</b>	The text for keypad buttons are in <b>Bold</b> capital letters.
CAPITAL LETTERS	The text for screen options are in regular capital letters.
<b>BACK ARROW</b>	The text for soft keys are in <b>Bold</b> capital letters.

## Assembling the GR8

The GR8 is shipped with the control module and mounting bracket packed separately. For easy assembly, follow these steps:

### Attaching the Control Module

1. The hardware to attach the control module's mounting bracket to the GR8 is installed on the top of the charger. There are three bolts with one flat washer, one lock washer, and one hex nut per bolt. Remove the washers and hex nuts, and set them aside.



One of three pre-installed bolts for the control module mounting bracket.

2. Center the three holes in mounting bracket over the bolts, and lower the bracket onto the charger. Reinstall the hardware in this order: the flat washer first, the lock washer next, and the hex nut last. Tighten the nuts securely.

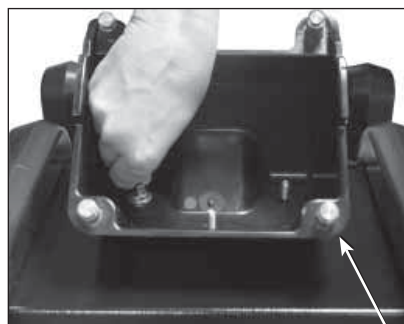

One of four pre-installed bolts on the bracket for mounting the control module.

- Center the holes on the bottom of the control module with the bolts, and lower the module onto the top of the bracket. Firmly pull the module down at an angle until the bolts are inserted securely into the slots extending from the module's holes.



### Installing the Multitasker Module

The GR8-1200 comes with a bracket to hold the multitasker module.

- Place the multitasker module in the bracket. Connect a serial cable between port B of the multitasker and the cart.

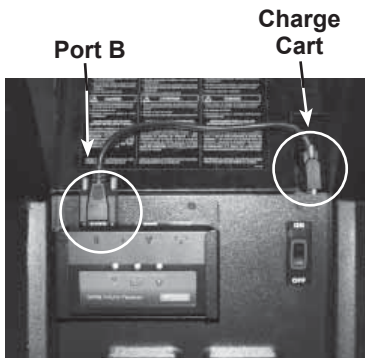

- Connect a serial cable between the control module and port A of the multitasker.

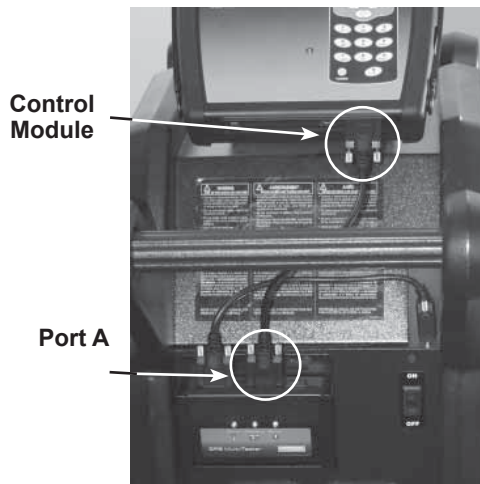



## Chapter 2: Overview

### Front of GR8

The controls to the GR8 are accessible on the front of the charger: the control module (user interface) and the ON/OFF switch.



#### 1 Control module

Backlit graphical display and keypad for data entry.

#### 2 Multitasker module

Dual connectors for testing more than one battery simultaneously.

#### 3 ON/OFF switch

Turns power on and off to the GR8.

#### 4 STATUS light

Lights in conjunction with beeping alarm to indicate transitions and warnings.

#### 5 Data card slot

For future upgrades via a data card. The slot contains a plastic filler card for protection.



### Back of GR8

In addition to containing the outlets for the charger cables and power cord, the back of the GR8 is the location for the serial numbers for the charger engine and the control module. Both numbers are necessary for warranty registration.

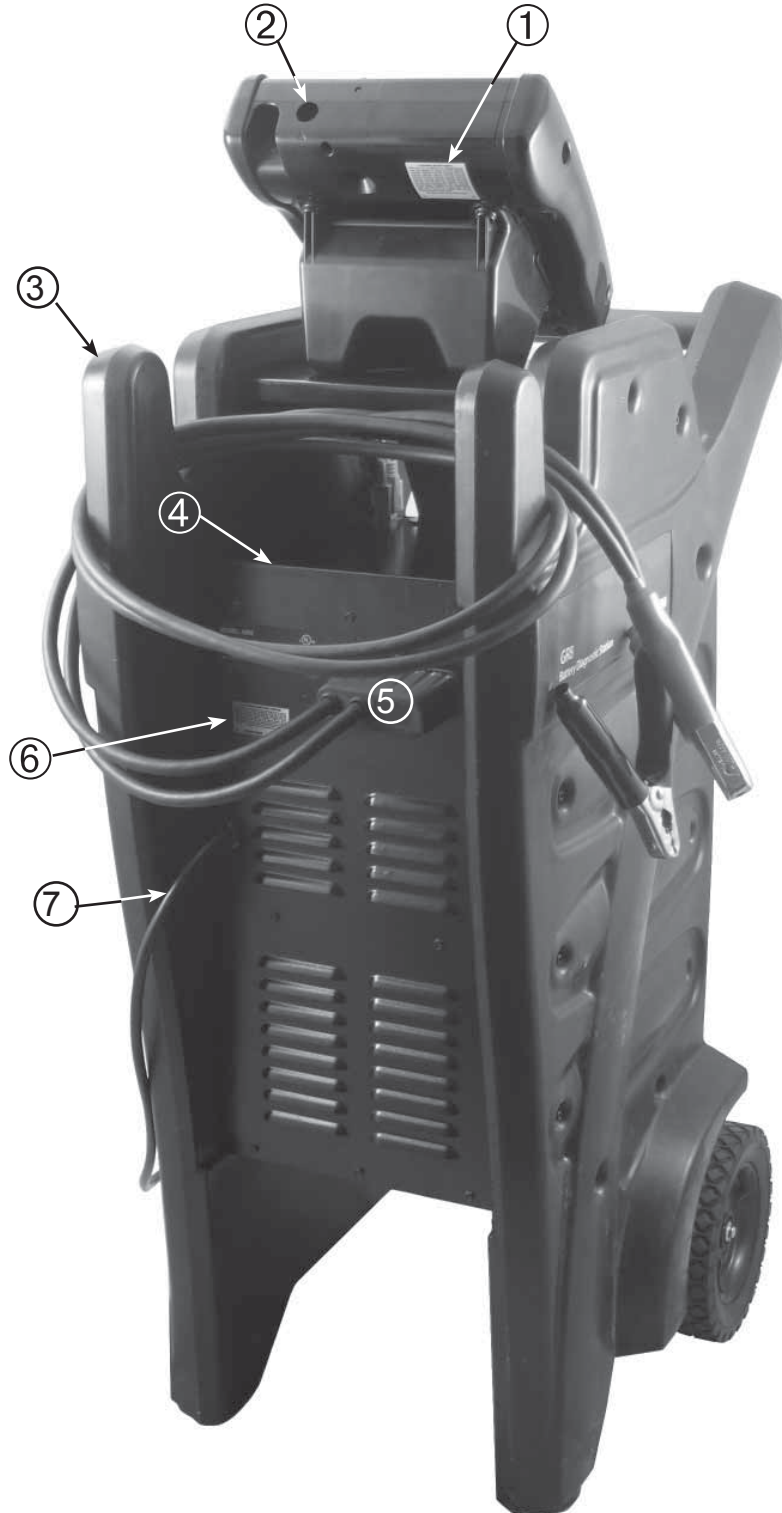

- 1 Serial number label**  
(for control module)
- 2 System test cable connector**
- 3 Cable wrap**  
For storing cables when not in use.
- 4 Storage shelf**
- 5 Charger cable connectors**
- 6 Serial number label**  
(for charger engine)
- 7 AC power cord**  
Connection to grounded nominal 120V outlet.

### Display and Keypad

The GR8 display and keypad work together to help you quickly find and use the right tools at the right time. The display also keeps you on track with onscreen navigation aids, directions and messages. The illustration shows how the elements on the screen relate to the keypad.

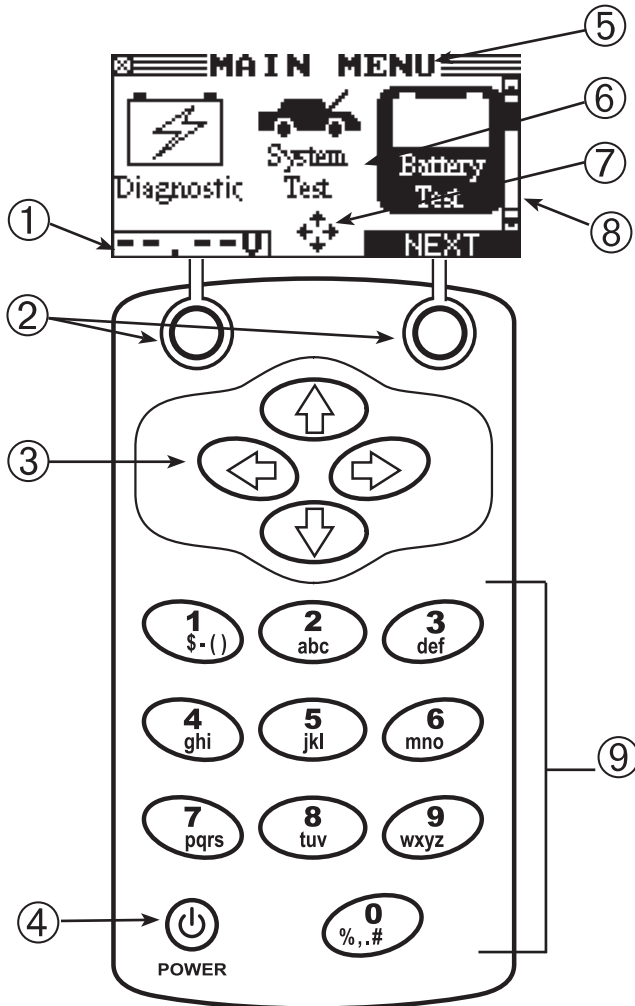

#### 1 Voltmeter

When you first connect the GR8 to a battery it functions as a voltmeter. The voltage reading appears above the left soft key until you move to other menus or functions.

#### 2 Soft Keys

Press the two soft keys linked to the bottom of the screen to perform the functions displayed above them. The functions change depending on the menu or test process. So it may be helpful to think of the words appearing above them as part of the keys.

#### 3 ARROW keys

Press the **ARROW** keys to scroll to numerical values and move to menus and icons

#### 4 POWER Key

Press the **POWER** key to turn the control module ON and OFF

#### 5 Title Bar

The title bar shows you the name of the current menu, test tool, utility, or function.

#### 6 Selection Area

The selection area below the **Title Bar** contains selectable items or dialog boxes that display information or require a response.

#### 7 Menu Screen Arrows

When displayed in menu screens, the menu screen arrows show you which **ARROW** key on the keypad to press to display other icons or screens. The Up and Down Menu Screen Arrows, for example, indicate when to press the UP or DOWN ARROW keys to display the screens above and below the current screen.

The Left and Right Menu Screen Arrows tell you when to use the **LEFT** (◀) or **RIGHT** (▶) **ARROW** keys to select an icon.

When displayed under a list of options, the menu screen arrows show you which keypad arrow to press to highlight a character or item in a list.

### 8 Scroll Bar

Another navigational aid is the scroll bar on the right side of the screen. The position of its scroll box shows you whether the screen is the top (or only screen), middle, or last in a series.

Some screens also indicate the page order with a notation such as P1/3 (page 1 of 3).

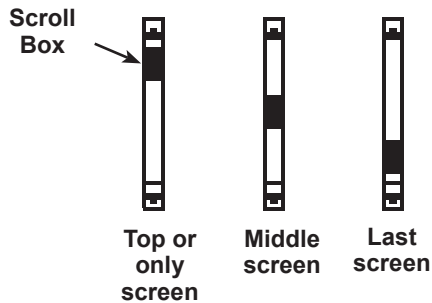

### 9 Alphanumeric Keypad

In some cases, you can use the alphanumeric keypad to enter numerical test parameters instead of scrolling to them with the **ARROW** keys.

You can also use the alphanumeric keys to create and edit customer coupons and your shop contact information on printed test results, and manage User IDs.

To add a space, press the **RIGHT ARROW** key. To erase a space and insert a character, press the **LEFT ARROW** key.

Refer to the table below for the characters associated with each alphanumeric key.

Table 3: Alphanumeric Keys and Associated Characters

Key	Character
1	\$ - ( ) 1
2	a b c 2
3	d e f 3
4	g h i 4
5	j k l 5
6	m n o 6
7	p q r s 7
8	t u v 8
9	w x y z 9
0	% , . # 0

### Data Entry Methods

To perform a particular test or function, the GR8 requires different types of information. This means that the methods you use to enter information will change depending on the type of information requested. The six types of entry methods are described below.

Typically, the soft key below the right half of the screen confirms your choice, although the command above it may vary. (Examples: **SELECT**, **NEXT**, and **SAVE**.) In a similar fashion, the soft key below the left half of the screen cancels your choice or returns you to the previous screen, although the word above it may also vary. (Examples: **BACK** and **CLEAR**.)

#### Menu Icons

A menu icon is a graphical representation of a function you can select, such as the Diode Icon in the DMM Menu. To select an icon, use the **LEFT** or **RIGHT ARROW** key to highlight it. Highlighting changes the icon to a white picture on a black background. To confirm your selection, press the appropriate soft key.

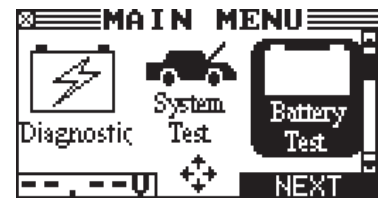

#### Option Buttons

Some lists have option buttons before each item. To select an item, use the UP or DOWN ARROW keys to move the dot to the button next to the item. To confirm your selection, press the appropriate soft key.

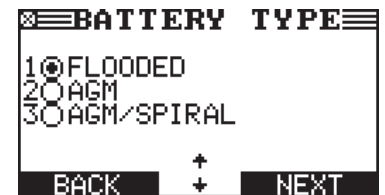

You can also use the alphanumeric keypad to enter the number preceding the option button of your choice. No additional keypress is needed to proceed.

#### Scrolling Lists

Scrolling lists contain items that extend above and below the screen. The first number above the right soft key indicates the position in the list of the highlighted item. The second number above the right soft key indicates the number of items in the list.

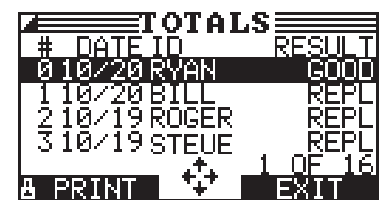

To select an item, the UP or DOWN ARROW key to highlight the item, and press the appropriate soft key.

To move the highlight bar up five lines at a time, press the **LEFT (◀) ARROW**. To move the highlight bar down five lines at a time, press the **RIGHT (▶) ARROW** key.

### Alphanumeric Entry

Some selections require you to use the alphanumeric keypad. These “user-defined” selections have a blinking horizontal line (cursor) to the right of the last character.



Use the UP or DOWN ARROW keys to highlight a line for editing. Display the character, symbol, or number you want by rapidly pressing its key as many times as needed. If you pause, the cursor moves to the right. To backspace, press the **LEFT (◀) ARROW** key. Use the **RIGHT ARROW** key to add a space. Use the UP or DOWN ARROW keys to highlight a line for editing. When finished, press the appropriate soft key to save your settings.

### Value Boxes

Value boxes contain items that extend above and below the selection box that contain them. To indicate that there are more values, the symbols and appear to the right of the box.



To select, use the UP or DOWN ARROW key to scroll to the value, or use the keypad to enter the value directly, and press the appropriate soft key. In the illustration the left directional arrow indicates that you can press the **LEFT (◀) ARROW** key to clear all or part of the entry.)

### Main Menu

The Main Menu is the starting point for all tools and utilities, which are depicted as icons. Some icons lead directly to the function they represent, while others are menu icons that lead to two or more options.

Table 4: Main Menu Icons

Menu Icon	Description
Diagnostic	Automatically tests, charges, and provides battery decision using the information you select in a series of screens.
System Test	Tests a battery, and the starting and charging systems.
Battery Test	Tests a battery using the battery information you select in a series of screens.
ECM Power Supply	Tests and maintains battery voltage at 13.5 volts to provide uninterrupted reprogramming of ECMs and retain vehicle system settings.
Jump Start	Makes high output current available to boost charge an in-vehicle battery and assist in starting the engine.
Manual	Provides a timed charge that ranges from 5 to 120 minutes or a continuous charge that ends when you press the <b>STOP</b> key.
Print/View	Prints and displays the results of the last battery, starter, and electrical system test; a test stored on the data card; the last cable drop test; and the last inventory test.
Info *	Includes a utility to view and print test results, a total test counter, a data transfer utility, and the software version and date, and GR8 serial number for the control module.
Cable Drop Test	Test the voltage drop of circuits.
DMM *	Digital multimeter with 8 test meters, a temperature sensor, and options for clamps and probes.
Admin *	Includes fourteen utilities, many of which customize your user interface.
Help	Provides a list of topics and definitions. Also includes Midtronics Customer Service phone numbers.

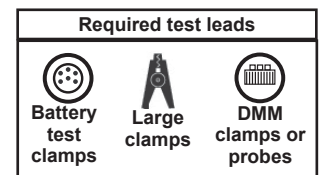

\*Menu icons marked with an asterisk (\*) are mapped on the following pages.

**Print/View Menu**



Allows you to view and print battery results.

**Info Menu**



The Info menu allows you to select Totals, Transfer results and view Software Version information.

**Table 5: Print/View Icons**

Menu Icon	Description
	Displays the last Battery results. Sends the results to the printer.
	Displays the last Charger results. Sends the results to the printer.
	Displays the last Cable Drop Test result. Sends the result to the printer.

**Table 6: Info Menu Icons**

Menu Icon	Description
	Display total results from the tester or charger.
	Transfers test results and counters to an IR receiver and data card.
	Displays wireless communication quality and channel being used.
	Lists the software version, version date, and serial number.

**DMM Menu**



The DMM menu has icons for a temperature sensor and 9 test meters, some of which require different test leads. The amp clamp, DMM clamps, and probes are options that you can purchase separately.

**Table 7: DMM Menu Icons**

Menu Icon	Description
	Measures voltage within a range of 0 to 60 Vdc.
	Measures voltage within a range of 0 to 24 Vac.
	Voltage trace with time and frequency measurements.
	Tests the strength of the direct current flow through a circuit.
	Tests the strength of the alternating current flow through a circuit.
	Sensor that displays temperature in degrees F or C (units you can select in the Utilities Menu.)
	Tests a circuit for continuity and resistance measured in ohms ( $\Omega$ ).
	Tests a diode for forward voltage drop.
	Measures two signals simultaneously: DC voltage and amperage.















## Admin Menu



The Admin Menu lets you customize your analyzer to suit your needs. Before testing, check default values to see what options you may want to change.

Admin

**Table 7: Admin Men Icons**

Menu Icon	Description
 Clock	Settings to adjust the time.
 Shop	Enables you to add a custom header to printed test results.
 Users	Add, edit, or delete User IDs.
 Display	Settings to adjust the screen contrast and backlight time.
 Coupon	If you've created a coupon in the Edit Coupon utility, use Coupon to turn it on and off.
 Edit Coupon	Enables you to create a coupon at the bottom of printed test results.
 Temp	Allows you to select degrees in C or F for temperature measurements.
 Language	Sets the language of the display and printouts.
 Format	Formats the data card to receive data. Also erases all data on the card.
 Update	Updates the GR8 software using files on an data card.
 Admin	Offers additional administration options such as showing the user ID and headers for printouts.
 Printer	Select between internal or IR external printer.
 Buzzer	Allows you to turn the buzzer OFF. Default is ON.
 User Screen	User-defined questions with the answers stored in data files on the data card.
 Wireless	Scans for interference and recommends the best channel for wireless communication.

## Chapter 3: Getting Started

The instructions in this section will help you quickly put your GR8 to work.

### Logging In for the First Time

#### Bootup

When you turn on the GR8, it will initially show the GR8-1200 logo. Screen may take up to ten seconds to boot up while testing the internal software integrity.



#### Selecting A Language

After the logo appears, the first selection screen to appear enables you to temporarily set the language for the display and printed test results.

Use the UP or DOWN ARROW, or press the corresponding numerical key to move the dot to the option button of your choice.

- 1  ENGLISH
- 2  ESPAÑOL
- 3  FRANÇAIS

Press the **NEXT** soft key to continue.

#### User ID

This function enables you to select the user name of the person performing the tests. Up to 50 user names can be created and stored.

- 1. ADD USER
- 2. JOHN
- 3. TOM

Press the **NEXT** soft key to begin testing.



**NOTE:** The BACK option is only available when the charger is used for the first time.

#### Adding a User

- Use the DOWN ARROW key to scroll to ADD USER. Press the NEXT soft key to continue.

0 UNREG

1 ADD USER

- Use the UP or DOWN ARROW key to scroll to the ID placeholder you want to use. Scrolling past the first line displays the previous screen. Scrolling past the fourth line displays the next screen. To display more placeholders, continue scrolling or use the **LEFT** or **RIGHT ARROW** key to jump up or down through the list five lines at a time. Press the **NEXT** soft key to continue.

1 USER01

2 USER02

3 USER03

4 USER04

- To clear the default characters, press the **LEFT ARROW** key. To add a space, move the cursor forward by pressing the **RIGHT ARROW** key.

ENTER USER ID

USER01

- Display a character by pressing UP or DOWN ARROW key as many times as needed. Press the **SAVE** soft key.

ENTER USER ID

WILL S

### **CAUTION**

**Do not connect both sets of clamps to the same battery at the same time.**

Connecting both sets of clamps to the same battery at the same time may damage the GR8.



## Setting User Preferences

Before starting your test you may want to customize the use of your GR8 by setting preferences in the Admin Menu. The menu has settings for the time, the contrast and backlight time, a utility to customize printouts for the optional IR printer, among others. The admin utilities are described in Chapter 15 on page 40.

## Help Menu



The GR8 provides a Help Menu with a glossary of test-related definitions that you may want to review prior to testing.

This menu also provides troubleshooting information and phone numbers for Midtronics Customer Service, in case you encounter a problem and/or need technical assistance.

Select the HELP icon from the Main Menu.

---

## Multitasking

The GR8-1200 Multitasking Battery Diagnostic Station is capable of doing two jobs at once. Historically a charger or tester could only perform one function at a time. The GR8-1200 Multitasking Battery Diagnostic Station has the ability to charge or test the battery and the electrical system of a vehicle independently while a second battery is being charged.

### Wireless Multitasking

The Multitasker communicates with the control module using RF radio signals. Once a charge session has begun, the control module can be disconnected and removed to test another vehicle in the service bay—thus, acting as two tools in one. The Multitasker will control the charge session when the control module is removed. The charge session can be monitored with the control module even when it is not connected however, internal AA battery life will be reduced. Long-term monitoring of a charge session should be done while connected to the Multitasker.

## Procedure Summary

The best way to utilize the multitasking feature is to first test a battery using the system test and the associated battery test cable that comes from the top of the controller (See Chapter 7 for detailed System Test instructions). If the test decision for the battery is one that requires a charge then the controller will ask you if you want to charge the battery.

Select CONTINUE, swap out the tester cables for the charging cables, and the controller will now analyze the battery for the optimal charging conditions. See Chapter 6 for detailed Diagnostic Charging instructions. Once the charge process has started you can go back to the main menu and continue to run system tests while the charger is charging.

Starting with the battery test is recommended so that a good battery decision can quickly be reached. While the charger can also be used and will reach the same decision, it is designed to determine the optimum charging method for a battery and therefore will take longer before reaching a decision. The same holds true for a bad cell or other physical flaws that will cause a replace battery decision.

## Chapter 4: Test Preparation

### Inspecting the Battery

Before starting the test visually inspect the battery for:

- Cracked, buckled, or leaking case. If you see any of these defects, replace the battery.
- Corroded, loose, or damaged cables and connections. Repair or replace them as needed.
- Corrosion on the battery terminals, and dirt or acid on the case top. Clean the case and terminals using a wire brush and a mixture of water and baking soda.
- Low electrolyte level. If the electrolyte level is too low, add distilled water to fill up to 1/2 above the top of the plates and fully charge the battery. Do not overfill.
- Corroded or loose battery tray and hold-down fixture. Tighten or replace as needed.

### Testing Out-of-Vehicle (Battery Test)

The preferred battery test location is in the vehicle. However, if you plan to test out of the vehicle:

- Always disconnect the negative cable from the battery first and reconnect it last.
- Always use a carry tool or strap to lift and transport the battery.



**CAUTION:** When testing side-post or Group 31 batteries, always use lead terminal adapters provided with the GR8—do not test at the battery's steel bolts. To avoid damage, never use a wrench to tighten the adapters more than 1/4 turn. Failure to properly install lead terminal adapters, or using adapters that are dirty or worn, may cause false test results.

### Testing In-Vehicle (System Test)

Before starting the test, inspect the alternator drive belt. A belt that is glazed or worn, or lacks the proper tension, will prevent the engine from achieving the rpm levels needed for the test.

The preferred test position is at the battery posts. If you must test at a remote-post location, it should have both a positive and negative post. Otherwise, you must remove the battery and perform a System Test.

At the start of the test, place the vehicle transmission in PARK, make sure all vehicle accessory loads are off, the key is not in the ignition, and the doors are closed.

### Connecting to the Battery

Connect the charging clamps to the battery in accordance with all precautions and safety instructions. **Do not connect either clamp to the vehicle's chassis.**

Connect the red clamp to the positive (+) terminal and the black clamp to the negative (-) terminal.

If you connect the clamps in the wrong polarity (red to negative or black to positive), the analyzer sounds an alarm and displays CLAMPS REVERSED! Reconnect the clamps.

To make sure both sides of the clamps are gripping the terminals, rock the each clamp back and forth. A poor connection will prevent testing, and the analyzer displays the message CHECK CONNECTION. If the message reappears after you have correctly reconnected the clamps, clean the terminals and reconnect.

### Connecting to AC Power

Plug the charger into a dedicated, grounded nominal 15-amp or higher AC outlet. Press the power switch to the ON position.

## Chapter 5: Diagnostic Charging



Diagnostic

The GR8-1200 battery analyzer and diagnostic charger will determine the internal condition of a battery before attempting to apply a charge to it.

The charger applies an AC signal at a known frequency across the terminals and measures the internal conductance to determine battery health before attempting to charge.



**NOTE:** When you start a new test, the last test results in memory are overwritten. Remember to record or print the results if you need to retain them.

### IMPORTANT

Only the large clamps from the GR8 charge engine should be connected to the battery terminals when performing diagnostic charging.

Before performing a diagnostic charge on a battery installed in a vehicle, make sure all vehicle accessory loads are off, the key is not in the ignition, and the doors are closed.

1. In the Main Menu, highlight the DIAGNOSTIC icon and press the SELECT key.

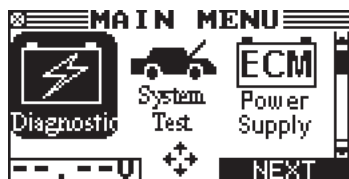

2. Use the UP or DOWN ARROW key to select the battery LOCATION, or press the corresponding numerical key (1 or 2) to move the dot to the option button of your choice.

1.  IN VEHICLE
2.  OUT OF VEHICLE

3. Use the UP or DOWN ARROW key to make your selections or press the corresponding numerical key (1 or 2).

1.  BELOW 250 MILES
2.  ABOVE 250 MILES



**NOTE:** To display Kilometers, change the temperature default to DEGREES C. Select ADMIN / TEMP from the Main Menu to access this setting

4. Use the UP or DOWN ARROW key to select the battery POST TYPE.

1.  TOP POST
2.  SIDE POST

The BACK soft key returns you to the Main Menu at the start of the test and to the previous screen as you progress.

5. Select the BATTERY TYPE.

1.  REGULAR/FLOODED
2.  AGM
3.  AGM SPIRAL

Press the NEXT soft key to continue.

6. Select the battery's rating units. The rating units and rating information required in the next step are printed on the battery label. If the information is unreadable, contact the battery manufacturer.

1.  CCA
2.  CA
3.  JIS
4.  DIN
5.  SAE
6.  IEC
7.  EN
8.  MCA

If you select JIS, the analyzer will ask for the JIS part number. Scroll to the part number. To increase your scrolling speed, hold the UP or DOWN ARROW key, or use the LEFT or RIGHT ARROW key to move up or down four part numbers at a time. Press ENTER to continue.

Press the NEXT soft key to continue.

Table 8: Battery Ratings

Ratings	Description	Range
CCA	Cold Cranking Amps (specified by SAE): The amount of current a battery can provide at 0 °F (-17.8 °C).	100 to 3000
CA	Cranking Amps: The amount of current a battery can provide at 32°F (0 °C).	100 to 3000
JIS	Japanese Industrial Standard: (shown on a battery as a combination of numbers and letters.	72 numbers from 26A17 to 245H52
DIN (A)	Deutsche Industrie-Norm	100 to 1000
SAE (A)	European labeling of CCA	100 to 3000
IEC (A)	International Electrotechnical Commission	100 to 1000
EN (A)	Europa-Norm	100 to 1700
MCA	Marine Cranking Amps: The amount of current a battery can provide at 32°F (0 °C).	100 to 3000

- Press an UP or DOWN ARROW key to select the BATTERY RATING. Press ENTER.



If you select JIS, the analyzer will ask for the JIS part number. Scroll to the part number. To increase your scrolling speed, hold the UP or DOWN ARROW key, or use the LEFT or RIGHT ARROW key to move up or down four part numbers at a time. Press ENTER to continue.

### Charging Modes

Diagnostic Charging has four modes (Initial Analysis, Diagnostic Mode, Recovery Mode, Top-Off Mode) that the GR8 may use to determine the State-of-Health of the battery while bringing it to a full State-of-Charge.

### Initial Analysis

The GR8 first analyzes the battery and makes a decision: GOOD BATTERY, REPLACE BATTERY, or REPLACE-BAD CELL. For diagnostic charge analysis, progress is shown by the left to right movement of a progress bar.



### Deep Scan Test

In some cases the GR8 may need to further analyze the battery to determine whether the battery should be replaced or it has a significant chance to be recovered. It will then conduct a Deep Scan Test of the battery for a few seconds.



After the Deep Scan Test the GR8 will either display the results or give you the option to perform the 5-Minute Discharged Battery Test. Although this test takes several minutes, it gives a more precise result for difficult-to-diagnose batteries. The decision tree of the test is shown below.

### Diagnostic Mode

Once the GR8 determines that the battery is good, needs charging, and is safe to charge, it proceeds to Diagnostic Charge Mode. During the charging session, the GR8 provides updates of the charging voltage, charging current, remaining time to charge, charging mode, and the amount of charge replenished into the battery in amp-hours. The GR8 continues to test the battery throughout Diagnostic Mode and may determine at some point that the battery needs to be replaced.



**NOTE:** The actual time needed to charge the battery may be less than the estimated time depending on the battery's charge acceptance.

When the battery requires testing, the display alternates between the CHARGING and TESTING screens. The TESTING screens represent a two-step process.

Step 1: The GR8 applies an electrical load and tests the battery's response.



Step 2: The GR8 measures the battery's CCA.

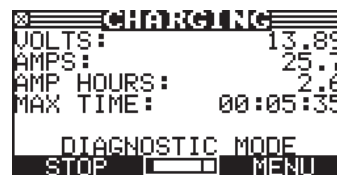

### Recovery Mode

In some cases the GR8 goes into Recovery Mode before displaying the final results. Recovery Mode optimizes the charge for a hard-to-charge battery.

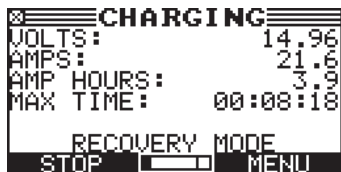

The maximum charge time in Recovery Mode is 1.5 hrs for customer vehicles and 3 hrs for dealer vehicles, although most batteries will finish charging sooner. During Recovery Mode the charger continuously analyzes the battery to make a decision as quickly as possible.

### Top-Off Mode

Following the Diagnostic Charge Mode process the GR8 will prompt you to stop the process or continue on in Top-Off Mode. After two minutes the GR8 will automatically enter Top-Off mode if there is no user input

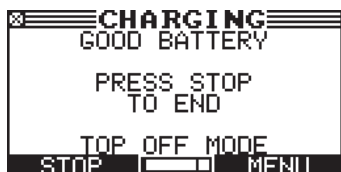

This mode occurs automatically at the end of the charge cycle to allow the charger to fill a good battery to capacity. Top-Off Mode ends when the battery's acceptance of the charge current goes below 2 amps, or when you press the **STOP** button.

### Aborting a Charge Session

If you need to abort the charging session, press and hold the **STOP** key until the charging session is aborted. After aborting, select **NEXT** to return to the Main Menu.

### Completing a Charge Session

The charge session is complete when the proper amount of charge is put back into the battery or the remaining estimated time to charge counts down to zero.

If the GR8 finds that the battery is bad before the end of the estimated time to charge, it displays the decision **REPLACE BATTERY** or **BAD CELL-REPLACE** and the results.

If charging at the side posts or jump start posts and the test data is inconclusive, the GR8 displays the decision **JUMP START POST** or **SIDE POST TEST**. A **JUMP START POST** decision prompts you to test at the battery. A **SIDE POST TEST** decision prompts you to test using the side post adapters.

When the decision is **GOOD BATTERY**, the GR8 gives you the option of topping off the battery's charge level before it displays the results.

### Diagnostic Charge Results

Use the **UP** or **DOWN ARROW** keys to scroll to each screen. To return to the Main Menu, press the **EXIT** soft key. To print, press the **PRINT** soft key.

Screen 1 of 3

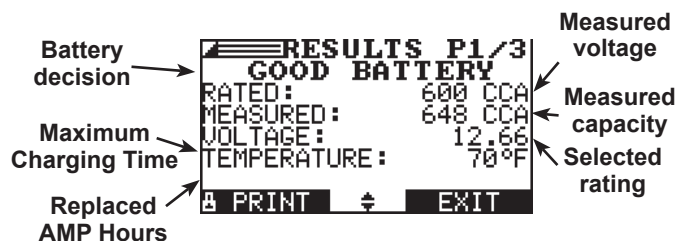

Screen 2 of 3



Screen 3 of 3

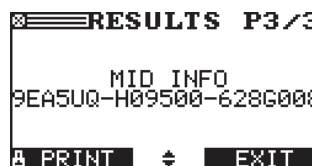

Table 9: Battery Decisions: Diagnostic Charge

Decision	Recommended Action
GOOD BATTERY	Return the battery to service.
REPLACE BATTERY	A REPLACE BATTERY result may also mean a poor connection between the battery and the vehicle. If you tested the battery using the System test, disconnect the battery cables and retest using the Battery Test before replacing it.
BAD CELL–REPLACE	Replace the battery. <b>WARNING: Do not charge the battery. Charging a battery with one or more bad cells could cause an explosion and serious harm to the user.</b>

## Chapter 6: System Test



The GR8 guides you through the steps of selecting your battery test parameters and interpreting the results. Before you start the test, review the instructions in Chapter 4: Test Preparation on page 21.



**NOTE:** When you start a new test, the last test results in memory are overwritten. Remember to record or print the results if you need to retain them.

### IMPORTANT

Only the small clamps from the GR8 charge engine should be connected to the battery terminals when performing System Test.

If you use the ARROW keys to select option buttons, press the NEXT soft key to continue to the next step.

1. In the Main Menu select the System Test icon.

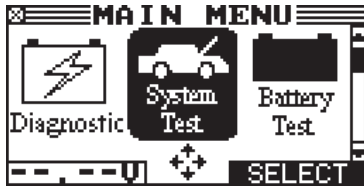

2. Use the UP or DOWN ARROW key to select the battery LOCATION, or press the corresponding numerical key (1 or 2) to move the dot to the option button of your choice.
  1.  IN VEHICLE
  2.  OUT OF VEHICLE
3. If you using the AMP CLAMP option, select AVAILABLE. If you are not using the AMP CLAMP, select NOT AVAILABLE.
  1.  AVAILABLE
  2.  NOT AVAILABLE

If you are using the amp clamp, plug it into the Control Module and follow the procedure for setting it to zero.
4. Use the UP or DOWN ARROW key to make your selections or press the corresponding numerical key (1 or 2).
  1.  BELOW 250 MILES
  2.  ABOVE 250 MILES



**NOTE:** To display Kilometers, change the temperature default to DEGREES C. Select ADMIN / TEMP from the Main Menu to access this setting.

5. Use the UP or DOWN ARROW key to select the battery POST TYPE. The JUMP START POST appears for the IN VEHICLE test only.
  1.  TOP POST
  2.  SIDE POST
  3.  JUMP START POST

The BACK soft key returns you to the Main Menu at the start of the test and to the previous screen as you progress.

6. Select the BATTERY TYPE.
  1.  REGULAR/FLOODED
  2.  AGM
  3.  AGM SPIRAL

Press the NEXT soft key to continue.

7. Select the battery's rating units. The rating units and rating information required in the next step are printed on the battery label. If the information is unreadable, contact the battery manufacturer.
  1.  CCA
  2.  CA
  3.  JIS
  4.  DIN
  5.  SAE
  6.  IEC
  7.  EN
  8.  MCA

If you select JIS, the analyzer will ask for the JIS part number. Scroll to the part number. To increase your scrolling speed, hold the UP or DOWN ARROW key, or use the LEFT or RIGHT ARROW key to move up or down four part numbers at a time.

Press the NEXT soft key to continue.

**Table 10: Starter System Decisions and Recommendations**

Ratings	Description	Range
CCA	Cold Cranking Amps (specified by SAE): The amount of current a battery can provide at 0 °F (-17.8 °C).	100 to 3000
CA	Cranking Amps: The amount of current a battery can provide at 32°F (0 °C).	100 to 3000
JIS	Japanese Industrial Standard: (shown on a battery as a combination of numbers and letters.	72 numbers from 26A17 to 245H52
DIN (A)	Deutsche Industrie-Norm	100 to 1000
SAE (A)	European labeling of CCA	100 to 3000
IEC (A)	International Electrotechnical Commission	100 to 1000
EN (A)	Europa-Norm	100 to 1700
MCA	Marine Cranking Amps: The amount of current a battery can provide at 32°F (0 °C).	100 to 3000

- Press an UP or DOWN ARROW key to select the BATTERY RATING. Press ENTER.



If you select JIS, the analyzer will ask for the JIS part number. Scroll to the part number. To increase your scrolling speed, hold the UP or DOWN ARROW key, or use the LEFT or RIGHT ARROW key to move up or down four part numbers at a time. Press ENTER to begin the battery test.

- Hold the bottom of the analyzer two inches above the battery case so that the IR temperature sensor on its underside can approximate the battery temperature. Press NEXT to continue.

**Battery Test Results**

After the test, the analyzer displays a battery decision with an analysis in a series of screens. The analysis includes the battery state-of-health (SOH) and state-of-charge (SOC). See Table 3: Battery Decisions for an explanation of the battery decisions.

**Table 11: Battery Decisions: System Test**

Decision	Recommended Action
GOOD BATTERY	Return the battery to service.
GOOD-RECHARGE	Fully charge the battery and return it to service.
CHARGE & RETEST	Fully charge the battery using a Midtronics Diagnostic Charger and retest. <b>Failure to fully charge the battery before retesting may cause false readings.</b> If CHARGE & RETEST appears again after you fully charge the battery, replace the battery.
REPLACE BATTERY	A REPLACE BATTERY result may also mean a poor connection between the battery and the vehicle. If you tested the battery using the System test, disconnect the battery cables and retest using the Battery Test before replacing it.
BAD CELL-REPLACE	Replace the battery. <b>WARNING: Do not charge the battery. Charging a battery with one or more bad cells could cause an explosion and serious harm to the user.</b>
SIDE POST TEST	Test data was inconclusive using the side post. Retest using side post adapters.
JUMP START POST	Data was inconclusive using the jump start post. Retest at the battery terminals.
24V	24-volt battery detected. You are attempting to test in-vehicle both batteries in a 24-volt system. Disconnect the batteries and test them individually.



Use the UP or DOWN ARROW key to scroll to each screen. To return to the Main Menu, press the END soft key. If you are performing a System Test, press the NEXT key to continue with the Starter System Test.

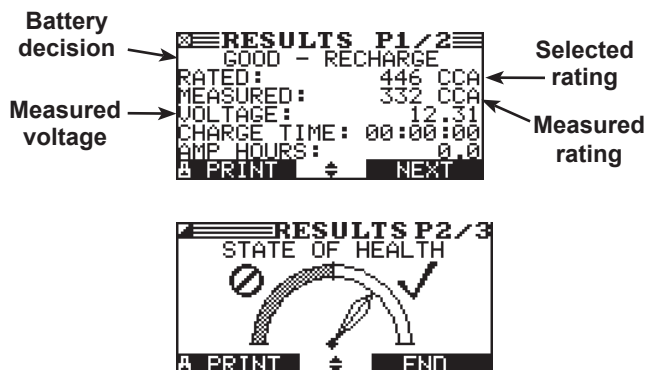

**Starter System Test Results**

Screen 1 of 2

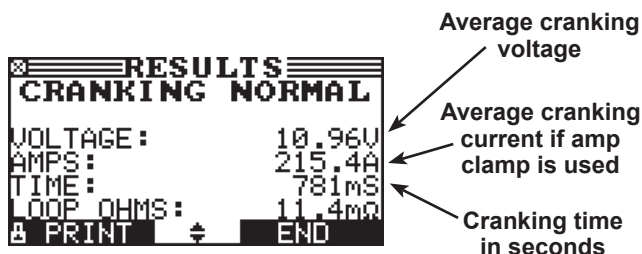

Screen 2 of 2

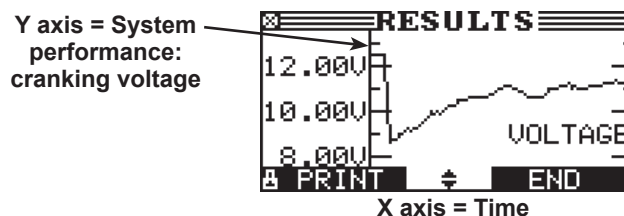

**Starter Test**

1. When prompted, start the vehicle's engine.
2. The GR8 will display 1 of 8 starter decisions with the complete results in a series of screens similar to those shown on the right. Use the UP or DOWN ARROW keys to scroll to each screen.

To print, press the PRINT soft key. To continue testing, press the NEXT soft key.

**NOTE:** In some cases, the GR8 may not detect the vehicle's starting profile and will display the options STARTED and NO START. Select STARTED, to continue with an alternator test. Select NO START to end the test process.

**Table 12: Starter System Decisions and Recommendations**

Decision	Action Recommended
CRANKING NORMAL	The starter voltage is normal and the battery is fully charged.
LOW VOLTAGE	The starter voltage is low and the battery is fully charged.
CHARGE BATTERY	The starter voltage is low and the battery is discharged. Fully charge the battery and repeat the starter system test.
REPLACE BATTERY	(If the battery test result was (REPLACE or BAD CELL.) The battery must be replaced before testing the starter.
NO START	The engine didn't start and the test was aborted.
CRANKING SKIPPED	The GR8 didn't detect the vehicle's starting profile and skipped the Starter Test.

### Charging System Test

When you press NEXT in any test result screen, the analyzer proceeds to the Charging System Test.

1. CHECKING FOR ALTERNATOR OUTPUT: The analyzer is testing for alternator voltage.
2. TURN ALL VEHICLE LOADS OFF, IDLE ENGINE: Turn off vehicle loads (blowers, interior light, radio, etc.) and idle the engine. Press the NEXT soft key to continue.
3. REV ENGINE WITH LOADS OFF FOR 5 SECONDS: Rev the engine with the loads off. Gradually increase the rpm until the analyzer tells you to HOLD the rev level as the bar on the display moves to the right.



**NOTE:** Some 8-cylinder and older vehicles idle at a high level after starting, allowing the analyzer to detect the rev automatically.

4. ACQUIRING DATA....HOLD ENGINE RPM: Continue to hold the rpm while the analyzer takes system measurements.
5. ENGINE REV DETECTED, IDLE ENGINE: The analyzer has detected the rev. Press the NEXT soft key.
6. TESTING ALTERNATOR AT IDLE, LOADS OFF: The analyzer will next test the engine at idle for comparison to other readings, and then test the diode ripple. Excessive ripple usually means one or more diodes have failed in the alternator or there is stator damage.
7. TURN HIGH BEAMS AND BLOWER MOTOR ON, IDLE ENGINE: After a few seconds, the analyzer will ask you to turn on the accessory loads. It will determine if the charging system is able to provide enough current for the demands of the electrical system.

**IMPORTANT!**

Turn on the high-beam headlights and the blower to high. Do not use cyclical loads such as air conditioning or windshield wipers.

8. TESTING ALTERNATOR AT IDLE, LOADS ON: The analyzer will determine if the charging system is able to provide sufficient current for the demands of the vehicle's electrical system.

9. REV ENGINE WITH LOADS ON FOR 5 SECONDS: The analyzer will test the charging system with the loads on and prompt you to rev the engine. Gradually increase the rev until the analyzer tells you to HOLD the rev level as the bar on the display moves to the right.
10. ACQUIRING DATA....HOLD ENGINE RPM: Continue to hold the rpm while the analyzer takes system measurements.
11. ENGINE REV DETECTED, IDLE ENGINE: The analyzer has detected the rev. Press the NEXT soft key.
12. ANALYZING CHARGING SYSTEM DATA: The analyzer is completing its final analysis of the charging system data.
13. TURN OFF LOADS AND ENGINE: Press the NEXT soft key to display the results.

### Charging System Test Results

Screen 1 of 3

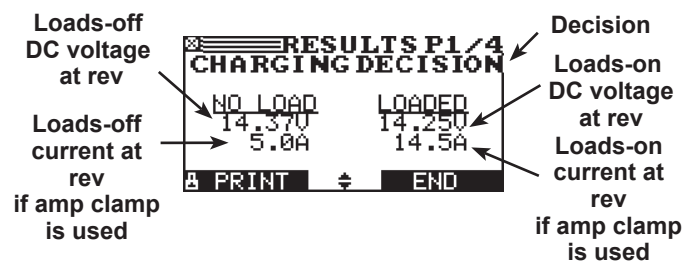

Screen 2 of 3

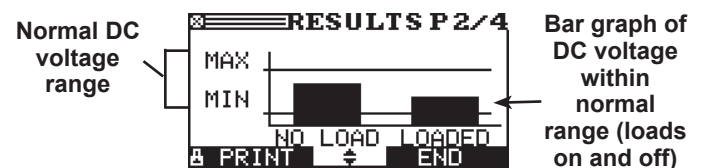

Screen 3 of 3

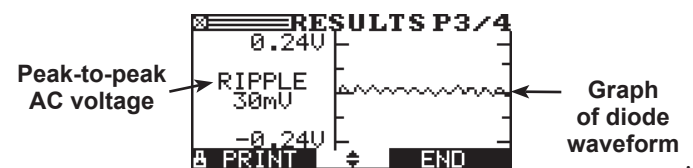

Table 13: Charging System Decisions

Charging System Decision	Action
NO PROBLEMS	The system is showing normal output from the alternator. No problem detected.
NO VOLTAGE	<p>The alternator is not providing charging voltage to the battery.</p> <ul style="list-style-type: none"> <li>√ Check the belts to ensure the alternator is rotating with the engine running. Replace broken or slipping belts and retest.</li> <li>√ Check all connections to and from the alternator, especially the connection to the battery. If the connection is loose or heavily corroded, clean or replace the cable and retest.</li> <li>√ If the belts and connections are in good working condition, replace the alternator. (Older vehicles use external voltage regulators, which may require only replacement of the voltage regulator.)</li> </ul>
LOW VOLTAGE	<p>The alternator is not providing enough voltage to power the system's electrical loads and charge the battery.</p> <ul style="list-style-type: none"> <li>√ Check the belts to ensure the alternator is rotating with the engine running. Replace broken or slipping belts and retest.</li> <li>√ Check the connections from the alternator to the battery. If the connection is loose or heavily corroded, clean or replace the cable and retest.</li> </ul>
HIGH VOLTAGE	<p>The voltage output from the alternator to the battery exceeds the normal limits of a functioning regulator.</p> <ul style="list-style-type: none"> <li>√ Check to ensure there are no loose connections and that the ground connection is normal. If there are no connection problems, replace the regulator. (Most alternators have a built-in regulator requiring you to replace the alternator. In older vehicles that use external voltage regulators, you may need to replace only the voltage regulator.)</li> </ul> <p>The regulator controls voltage output based on the battery voltage, under-hood temperature, and vehicle loads used. In other words, it controls the maximum voltage the system can produce based on the current needs and amount of current that can be produced by the spinning of the rotor in the alternator. The normal high limit of a typical automotive regulator is 14.5 volts +/-0.5. Refer to the manufacturer specifications for the correct limit, which may vary by vehicle type.</p> <p>A high charging rate will overcharge the battery and may decrease its life and cause it to fail. If the battery test decision is REPLACE and the charging system test shows a HIGH OUTPUT, check the battery's electrolyte levels. A symptom of overcharging is battery fluid spewing through the vent caps, which causes low electrolyte levels and will harm the battery.</p>

Diode Decision	Action
EXCESSIVE RIPPLE	<p>One or more diodes in the alternator are not functioning or there is stator damage, which is shown by an excessive amount of AC ripple current supplied to the battery.</p> <ul style="list-style-type: none"> <li>√ Make sure the alternator mounting is sturdy and that the belts are in good shape and functioning properly. If the mounting and belts are good, replace the alternator.</li> </ul>
OPEN PHASE	The analyzer has detected an open phase within the alternator. Replace the alternator.
OPEN DIODE	The analyzer has detected a open diode within the alternator. Replace the alternator.
SHORTED DIODE	The analyzer has detected an shorted diode within the alternator. Replace the alternator.

# Chapter 7: Battery Test

## Test Requirements



The GR8 guides you through the steps of selecting your battery test parameters and interpreting the results. Before you start the test, review the instructions in Chapter 4: Test Preparation on page 21.



**NOTE:** When you start a new test, the last test results in memory are overwritten. Remember to record or print the results if you need to retain them.

### IMPORTANT

Only the small clamps from the GR8 charge engine should be connected to the battery terminals when performing Battery Test.

If you use the ARROW keys to select option buttons, press the NEXT soft key to continue to the next step.

1. In the Main Menu select the Battery test icon.

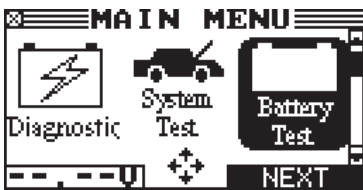

Press the NEXT soft key to continue.

2. Select the LOCATION. This is determined by whether the battery is in or out of a vehicle when it is tested.

- 1  OUT OF VEHICLE
- 2  IN VEHICLE

Press the NEXT soft key to continue.

3. Use the UP or DOWN ARROW key to make your selections or press the corresponding numerical key (1 or 2).

- 1  BELOW 250 MILES
- 2  ABOVE 250 MILES



**NOTE:** To display Kilometers, change the temperature default to DEGREES C. Select ADMIN / TEMP from the Main Menu to access this setting.

4. Select the POST TYPE. The JUMP START POST option appears for the IN VEHICLE test.

- 1  TOP POST
- 2  SIDE POST
- 3  JUMP START POST (In Vehicle Test Only)

Press the NEXT soft key to continue.

5. Select the BATTERY TYPE.

- 1  REGULAR FLOODED
- 2  AGM
- 3  AGM SPIRAL

Press the NEXT soft key to continue.

6. Select the battery's rating units. The rating units and rating information required in the next step are printed on the battery label. If the information is unreadable, contact the battery manufacturer.

- 1  CCA
- 2  CA
- 3  JIS
- 4  DIN
- 5  SAE
- 6  IEC
- 7  EN
- 8  MCA

If you select JIS, the analyzer will ask for the JIS part number. Scroll to the part number. To increase your scrolling speed, hold the UP or DOWN ARROW key, or use the LEFT or RIGHT ARROW key to move up or down four part numbers at a time. Press ENTER to continue.

Press the NEXT soft key to continue.

**Table 14: Battery Ratings**

Ratings	Description	Range
CCA	Cold Cranking Amps (specified by SAE): The amount of current a battery can provide at 0 °F (-17.8 °C).	100 to 3000
CA	Cranking Amps: The amount of current a battery can provide at 32°F (0 °C).	100 to 3000
JIS	Japanese Industrial Standard: (shown on a battery as a combination of numbers and letters.	72 numbers from 26A17 to 245H52
DIN (A)	Deutsche Industrie-Norm	100 to 1000
SAE (A)	European labeling of CCA	100 to 3000
IEC (A)	International Electrotechnical Commission	100 to 1000
EN (A)	Europa-Norm	100 to 1700
MCA	Marine Cranking Amps: The amount of current a battery can provide at 32°F (0 °C).	100 to 3000

- Press an UP or DOWN ARROW key to select the BATTERY RATING. Press ENTER.



If you select JIS, the analyzer will ask for the JIS part number. Scroll to the part number. To increase your scrolling speed, hold the UP or DOWN ARROW key, or use the LEFT or RIGHT ARROW key to move up or down four part numbers at a time. Press ENTER to continue.

- Hold the bottom of the analyzer two inches above the battery case so that the IR temperature sensor on its underside can approximate the battery temperature. Press NEXT to continue.

### Additional Test Requirements

For a more decisive result the analyzer may ask for additional information or further explore the battery's condition. The following messages and instructions may appear before the analyzer displays the results.

#### System Noise Detected

The analyzer has detected computer, ignition noise, or parasitic drain, and will attempt to retest. Make sure all vehicle loads are off, doors are closed, and the ignition is in the off position. The analyzer will automatically retest when it no longer detects system noise. If the message reappears:

- You may be testing too close to a noise source, such as a charger or other high-current device. If so, move away and retest.
- If you are unable to find the source of the noise, fully charge the battery and retest. If the message appears after recharging, test the battery out of the vehicle.
- Disconnect the battery cables and retest.

#### Unstable Battery Detected

A battery that is weak or that has just been charged may retain enough electrical activity to be detected by the analyzer and will adversely affect the test results. A fully charged battery should stabilize quickly, after which the analyzer will automatically retest. Weak batteries should be charged and retested. If the battery is fully charged, check the clamp connections.

#### Deep Scan Test

In some cases the analyzer may need to further analyze a deeply discharged battery to determine whether the battery should be replaced or if it has a chance to be recovered. It will then conduct a Dynamic Scan Test of the battery for a few seconds while displaying a battery being scanned.



### Battery Test Results

After the test, the analyzer displays a battery decision with an analysis in a series of screens. The analysis includes the battery state-of-health (SOH) and state-of-charge (SOC). See Table 3: Battery Decisions for an explanation of the battery decisions.

Use the UP or DOWN ARROW key to scroll to each screen. To return to the Main Menu, press the END soft key. If you are performing a System Test, press the NEXT key to continue with the Starter System Test.

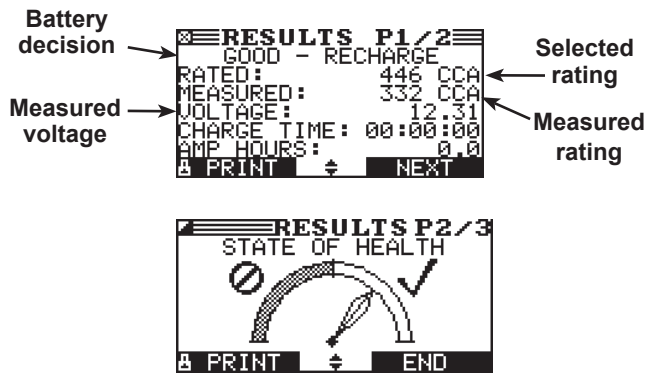

### State of Health (SOH)

The battery’s state of health represents its general condition, and therefore its ability to deliver the specified performance compared with a fresh battery.

Although a poor state-of-health can be the result of defects in construction, it is most often caused by normal wear, which depends on vehicle needs, climate, and operating conditions. These cause irreversible physical and chemical changes within the battery until it can no longer hold a charge and supply the power to start the car and provide auxiliary power to the electrical system. As the battery approaches end of life, its deterioration accelerates until it finally fails to start the vehicle. Before failing, the battery may start the vehicle under normal conditions but may not be able to operate in more extreme conditions. Extreme heat or cold could expose a weak battery and cause it to fail.

Table 15: Battery Decisions: Battery Test

Decision	Recommended Action
GOOD BATTERY	Return the battery to service.
GOOD-RECHARGE	Fully charge the battery and return it to service.
CHARGE & RETEST	Fully charge the battery using a Midtronics Diagnostic Charger and retest. <b>Failure to fully charge the battery before retesting may cause false readings.</b> If CHARGE & RETEST appears again after you fully charge the battery, replace the battery.
REPLACE BATTERY	A REPLACE BATTERY result may also mean a poor connection between the battery and the vehicle. If you tested the battery using the System test, disconnect the battery cables and retest using the Battery Test before replacing it.
BAD CELL-REPLACE	Replace the battery. <b>WARNING: Do not charge the battery. Charging a battery with one or more bad cells could cause an explosion and serious harm to the user.</b>
SIDE POST TEST	Test data was inconclusive using the side post. Retest using side post adapters.
JUMP START POST	Data was inconclusive using the jump start post. Retest at the battery terminals.
24V	24-volt battery detected. You are attempting to test in-vehicle both batteries in a 24-volt system. Disconnect the batteries and test them individually.

## Chapter 8: ECM Power Supply



Power Supply Mode tests and maintains battery voltage in the vehicle at 13.5 volts to allow for uninterrupted reprogramming of vehicle computers, retain vehicle system settings, or simply to maintain battery voltage.

### IMPORTANT

Only the large clamps from the GR8 charge engine should be connected to the battery terminals when performing diagnostic charging.

Before starting Power Supply Mode, verify that all vehicle loads are off and the key is not in the ignition.



**NOTE:** Start the Power Supply Mode to begin the control module reprogramming process.

1. If connected, remove the small tester clamps from the battery terminals and connect the large charger clamps.
2. In the Main Menu use the LEFT or RIGHT ARROW key to highlight the POWER SUPPLY icon. Press the NEXT soft key.



3. Use the UP or DOWN ARROW key to select the BATTERY TYPE, or press the corresponding numerical key to move the dot to the option button of your choice.
  - 1  REGULAR FLOODED
  - 2  AGM
  - 3  AGM SPIRAL

4. Press the NEXT soft key.

Before entering the Power Supply Mode, the GR8 will test the battery to determine if it needs to be charged. The following message will be displayed if the battery does not have a sufficient charge.

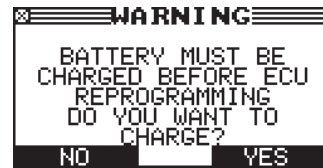

**NOTE:** If you choose to charge the battery, you will need to restart the Power Supply Mode once the battery has been successfully charged.



**NOTE:** The GR8 tests the battery to determine if it is safe to charge. If it detects that the battery is defective, it beeps, flashes the status light, and displays a warning that the battery is unsafe to charge. Press the EXIT soft key to return to the Main Menu.

5. If the battery is safe to charge, the GR8 begins maintaining the battery voltage at 13.5 volts.

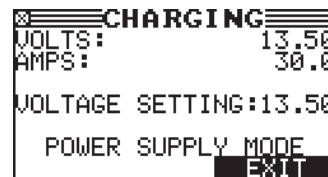

**NOTE:** Amperage fluctuates in response to the vehicle's demands. If the voltage drops below the 12.8, the GR8 displays a warning and raises the voltage to the set point.

6. When finished servicing the vehicle, press the STOP button or the OFF switch, unplug the power cord and disconnect the clamps.

# Chapter 9: Jump Start



This charging mode makes high output current available to boost charge an in-vehicle battery as well as assist in starting the engine. If you need to abort at any time, press the **STOP** key.

### IMPORTANT

Only the large clamps from the GR8 charge engine should be connected to the battery terminals when performing diagnostic charging.

1. In the Main Menu, highlight the JUMP START icon and press the NEXT key.

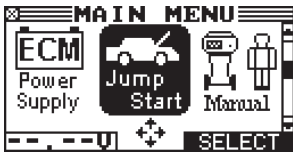

**NOTE:** The GR8 tests the battery to determine if it is safe to charge. If it detects that the battery is defective, it displays a warning that the battery is unsafe to charge. Press the EXIT soft key to return to the Main Menu.

2. Use the UP or DOWN ARROW key to select the BATTERY TYPE, or press the corresponding numerical key (1, 2, or 3) to move the dot to the option button of your choice.

- 1  REGULAR FLOODED
- 2  AGM
- 3  AGM SPIRAL

Press the NEXT soft key. The BACK soft key returns you to the Main Menu at the start of the test and to the previous screen as you progress.



**NOTE:** If you use the ARROW keys to select option buttons, press the NEXT soft key to continue to the next step. If you use the alphanumeric keypad to enter the number preceding the option button, no additional keypress is needed.

3. If the battery is safe to charge, the GR8 will prompt you to press the NEXT soft key to begin the boost charge
4. The GR8 begins boost-charging. Do not crank the engine at this time.
5. When the GR8 displays "CRANK ENGINE NOW," beeps and flashes the status light, you can crank the engine for up to five seconds.
6. When the GR8 displays "JUMP START COMPLETE," press the STOP key. (The alarm sounds every second until you press STOP.)



## Chapter 10: Manual Charging



The GR8 charges the battery based on the current limit or voltage limit, and charge duration that you select.



**CAUTION:** You must monitor the battery's State-of-Charge (SOC) and temperature to avoid overcharging. Any charging after the battery is fully charged can result in excessive battery temperature, which will "gas" the battery and boil off electrolytes, shortening battery life.

### IMPORTANT

Only the large clamps from the GR8 charge engine should be connected to the battery terminals when performing diagnostic charging.

1. In the Main Menu, highlight the MANUAL icon and press the **NEXT** key.



2. Use the UP or DOWN ARROW key to select the BATTERY TYPE, or press the corresponding numerical key to move the dot to the option button of your choice.

- 1  REGULAR FLOODED
- 2  AGM
- 3  AGM SPIRAL

Press the NEXT soft key. The BACK soft key returns you to the Main Menu at the start of the test and to the previous screen as you progress.

3. Use the UP or DOWN ARROW key to select the LIMIT TYPE, or press the corresponding numerical key (1 or 2) to move the dot to the option button of your choice.

- 1  LIMIT CURRENT
- 2  LIMIT VOLTAGE

Press the NEXT soft key. The BACK soft key returns you to the Main Menu at the start of the test and to the previous screen as you progress.



**NOTE:** If you use the ARROW keys to select option buttons, press the NEXT soft key to continue to the next step. If you use the alphanumeric keypad to enter the number preceding the option button, no additional keypress is needed.

4. You can set limits using VOLTAGE or CURRENT.

If your limit type is CURRENT, select the maximum amperage (1 to 60 amps). When in doubt, start with a low charging current. Press the NEXT soft key.

50 AMPS

If your limit-type is VOLTAGE, select the maximum voltage. The range for regular is 12.7 to 15.3 V; AGM is 12.7 to 14.4 V. Press the NEXT soft key.

12.40 VOLTAGE

5. Select a charge duration from 5 to 120 minutes, or select a duration greater than 120 minutes for Continuous charging. To select a timed charge when "CONTINUOUS" is displayed, use the keypad to enter a duration 5 and 120 minutes.

Continuous charging stops when you press the **STOP** key.

#### Timed Charge Selection Screen



#### Continuous Charge Selection Screen





**NOTE:** The GR8 tests the battery to determine if it is safe to charge. If it detects that the battery is defective, it displays a warning that the battery is unsafe to charge. Press the EXIT soft key to return to the Main Menu.

6. If the battery is safe to charge, the GR8 will begin charging at the selected levels. The illustration shows an example of the information displayed during timed charging

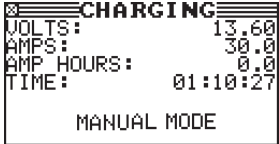

**NOTE:** If Continuous charge is selected, charging time is not displayed.

7. When Manual Mode ends, the GR8 displays the total charging time for Continuous and Timed Charging, the amp hours replaced, and the charging mode.

The alarm sounds every 30 seconds until you disconnect the clamps, or press the NEXT soft key.



## Chapter 11: Print / View Menu



The Print/View Menu enables you to view and print the results of the Battery, System, and Cable Drop Tests before you perform another test and overwrite the results in memory.

### ***View Test Battery***

VIEW TEST BATTERY gives you the option of viewing and printing the results of the Battery and System Tests. To print the results, select the PRINT soft key. To return to the Main Menu, press the END key.

### ***View Test Charger***

VIEW TEST CHARGER gives you the option of viewing and printing the results of the Charger Test. To print the results, select the PRINT soft key. To return to the Main Menu, press the END key.

### ***View Cable Test***

VIEW CABLE TEST gives you the option of viewing and printing the results of the Cable Drop Test. To print the results, select the PRINT soft key. To return to the Main Menu, press the END key.

## Chapter 12: Info Menu



The Info Menu will help you view your test data and track the usage and history of your GR8. The Info menu also allows you to view total history and transfer information to another machine.

### Totals



Totals

TOTALS counts the number of battery tests in two main categories: TESTER TOTALS and CHARGER TOTALS. Subcategories include: LIFETIME, USER TOTALS, LAST 100 LOG, TOTALS BY DECISION and SYSTEM TEST.

#### 1 LIFETIME

Total tests since the GR8 was first used.

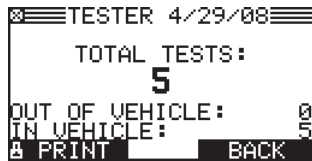

Tester Totals

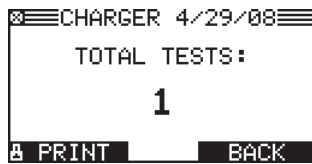

Charger Totals

#### 2 USER TOTALS

Total tests by User ID (and by UNREG user) since the first time a registered user logged in and the last time they were cleared by ADMIN.



#### 3 LAST 100 LOG

Last 100 tests performed by User ID (and by UNREG user); includes the date and the battery decision (GOOD, REPLACE, etc.).



#### 4 TOTALS BY DECISION

Totals by battery decision since the last time they were cleared by ADMIN.

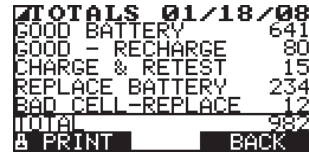

#### 5 SYSTEM TEST

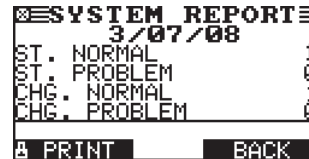

**NOTE:** The SYSTEM TEST option is only available under the TESTER TOTALS category.

### Transfer



Transfer

TRANSFER is an optional accessory that consists of an IR software and hardware package that will enable you to transfer test data to a PC.

### View Wireless



View Wireless

Displays communication quality and channel being used for wireless communication between the control head and the multitasking module.

### Version



Version

VERSION displays the GR8 software version, the date the software was released, and the serial number of the control module. The utility also allows you to print the information.

## Chapter 13: Cable Drop Test

### Cable Drop Test

If the test results for the starter or charging systems indicate that there may be a problem, you may want to perform the Cable Drop Test to determine if it is due to worn cables or bad connections between the battery and the alternator or starter. Worn cables or bad connections create higher resistance, which causes a voltage drop across the circuit. The voltage drop reduces current carrying capability that displays the same symptoms as a weak alternator or starter and causes premature battery failure.

There's no need to run the engine. The Cable Drop Test uses Midtronics' conductance technology to send a signal through the circuit at the component under test. The GR8 then simultaneously calculates voltage drop on the positive (+) and negative (-) sides of any circuit as well as the total voltage drop. The amperage range for each of the four tests is 0 to 1000 A. When you change the setting from the factory defaults, the GR8 will store your setting in memory for your next test.

There are three preset tests:

- BATTERY GROUND
- STARTER CIRCUIT
- ALTERNATOR CIRCUIT

A fourth test, OTHER CIRCUIT, tests other grounds and circuits against your specified amperage capacity.

The test requires two test lead connections, as shown in the figure below.

- Battery test leads at the component's output lead (the B+ or output screw on the alternator) and the component's housing as ground
- DMM test leads at the battery terminals



**NOTE:** The test requires a complete circuit. If you're testing a system with a remote solenoid, you can test from the battery to the solenoid, but not from the battery to the starter.

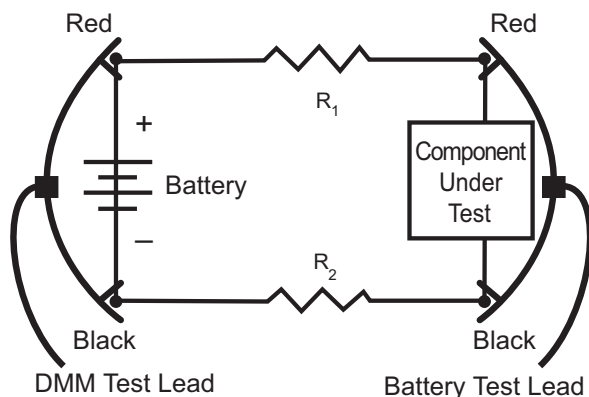

To begin, select the Cable Drop Test icon in the Main Menu and follow the instructions on the display.

**IMPORTANT:** For accurate results the battery should be good and fully charged before you perform a test.

### Battery Ground Test

The Battery Ground Test measures the voltage drop for the ground strap.

1. SELECT CIRCUIT: Use the **UP/DOWN ARROWS** or the numerical keypad to select the Battery Ground Test.
  - 1  BATTERY GROUND
  - 2  STARTER CIRCUIT
  - 3  ALT CIRCUIT
  - 4  OTHER

Press the **NEXT** soft key to continue.

2. SET AMPS: Use the **UP/DOWN ARROWS** or the keypad to select the rated amperage of the circuit you are testing. The default is 80 A.



Press the **NEXT** soft key to continue.

3. Connect the main clamps (battery test leads) to the battery and ground: positive (+) clamp to the battery's positive post; negative (-) clamp to the vehicle chassis.
4. Connect the DMM cable to the battery posts: positive (+) clamp to the positive post; negative clamp (-) to the negative post.

For the next few seconds the GR8 will display the word TESTING and a stopwatch while it evaluates the battery ground.

### Battery Ground Test Results

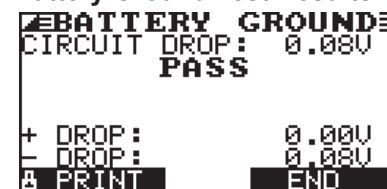

If there is a problem, the decision is CLEAN AND RETEST OR REPLACE. To print the results, select the **PRINT** soft key. To return to the Main Menu, press the **END** key.

### Starter Circuit

The Starter Circuit Test measures the voltage drop of the starter circuit.

1. SELECT CIRCUIT: Use the **UP/DOWN ARROWS** or the numerical keypad to select STARTER CIRCUIT.
  - 1  BATTERY GROUND
  - 2  STARTER CIRCUIT
  - 3  ALT CIRCUIT
  - 4  OTHER

Press the **NEXT** soft key to continue.

2. SET AMPS: Use the **UP/DOWN ARROWS** or the keypad to select the rated amperage of the starter circuit. The default is 150 A.



Press the **NEXT** soft key to continue.

3. Connect the positive (+) clamp of the battery test leads to the starter's battery terminal stud. Connect the negative (-) clamp to the starter's housing.
4. Connect the positive (+) DMM clamp to the battery's positive (+) post. Connect the negative clamp (-) to the battery's (-) negative post.

For the next few seconds the GR8 will display the word TESTING and a stopwatch while it evaluates the battery ground.

#### Starter Circuit Test Results



If there is a problem, the decision is CLEAN AND RETEST OR REPLACE. To print the results, select the **PRINT** soft key. To return to the Main Menu, press the **END** key.

### Alternator Circuit

The Alternator Circuit Test measures the voltage drop of the alternator circuit.

1. SELECT CIRCUIT: Use the **UP/DOWN ARROWS** or the numerical keypad to select ALT CIRCUIT.
  - 1  BATTERY GROUND
  - 2  STARTER CIRCUIT
  - 3  ALT CIRCUIT
  - 4  OTHER

Press the **NEXT** soft key to continue.

2. SET AMPS: Use the **UP/DOWN ARROWS** or the keypad to select the rated amperage of the alternator circuit. The default is 80 A.



Press the **NEXT** soft key to continue.

3. Connect the positive (+) clamp of the battery test leads to the alternator's output stud (B+). Connect the negative (-) clamp to the alternator's housing.
4. Connect the positive (+) DMM clamp to the battery's positive (+) post. Connect the negative clamp (-) to the battery's (-) negative post.

For the next few seconds the GR8 will display the word TESTING and a stopwatch while it evaluates the battery ground.

#### Alternator Circuit Test Results

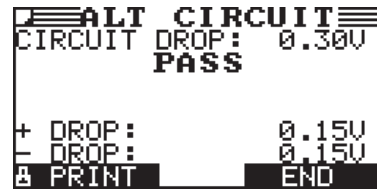

If there is a problem, the decision is CLEAN AND RETEST OR REPLACE. To print the results, select the **PRINT** soft key. To return to the Main Menu, press the **END** key.

### Other Circuit

This test enables you to measure voltage drop across other components.

1. SELECT CIRCUIT: Use the **UP/DOWN ARROWS** or the numerical keypad to select the OTHER.
  - 1  BATTERY GROUND
  - 2  STARTER CIRCUIT
  - 3  ALT CIRCUIT
  - 4  OTHER

Press the **NEXT** soft key to continue.

2. SET AMPS: Use the **UP/DOWN ARROWS** or the keypad to select the rated amperage of the circuit you are testing. The default is 10 A.

**10**  **A**

Press the **NEXT** soft key to continue.

3. Connect the positive (+) clamp of the battery test leads to the component's positive terminal (+). Connect the negative (-) clamp to the component's negative (-) terminal.
4. Connect the positive (+) DMM clamp to the battery's positive (+) post. Connect the negative clamp (-) to the battery's (-) negative post.

For the next few seconds the GR8 will display the word TESTING and a stopwatch while it evaluates the battery ground.

### Other Circuit Test Results

```

OTHER CIRCUIT
CIRCUIT DROP: 0.08V
PASS
+ DROP: 0.00V
- DROP: 0.08V
PRINT END
  
```

If there is a problem, the decision is CLEAN AND RETEST OR REPLACE. To print the results, select the **PRINT** soft key. To return to the Main Menu, press the **END** key.

## Chapter 14: Digital Multimeter (DMM)

### DMM



The GR8's 8 digital meters make it versatile enough to test everything from a vehicle's entire electrical system to a board-level component:

- DC Voltmeter
- AC Voltmeter
- Scope
- DC Ammeter
- AC Ammeter
- Ohmmeter
- Diode Drop
- Volts/Amp

The DMM's infrared temperature sensor also enables you to determine the surface temperature of components before you service them or as a diagnostic aid. Specifications for each tool are listed at the end of this chapter.

Select the DMM icon to display its METERS menu. The tools in this menu are available in a series of three screens.

A measurement that is out of the limit displays as *OL*. Refer to the manufacturer specifications for the correct limits, which may vary by component or vehicle type.

### DC Volts

The DC voltmeter measures voltage between two points in a circuit. The voltmeter is connected in parallel with the circuit.

1. Connect the DMM test lead to the GR8's accessories port.
2. Select the meter's icon.
3. Connect the clamps or probes in the correct polarity: red clamp or probe to positive (+); black to negative (-).
4. The meter will autorange and display the measurement.
5. To return to the METERS menu, press the **END** soft key.

### AC Volts

The AC voltmeter measures the AC volts between two points in a circuit. The voltmeter is connected in parallel with the circuit.

1. Connect the DMM test lead to the GR8's accessories port.
2. Select the meter's icon.
3. Connect the clamps or probes in the correct polarity: red clamp or probe to positive (+); black to negative (-).
4. The meter will autorange and display the measurement.

5. To return to the METERS menu, press the **END** soft key.

### Scope

The scope is a voltmeter that provides a graph of voltage difference as it varies over time. After you select the scope icon, note the instructions in the next screen before proceeding. You'll need the them after you press the **NEXT** soft key to continue:

- Press 1 on the keypad to autoscale the scope.
- Press 3 on the keypad for the time display.
- Press 4 on the keypad for the FFT (frequency) display.

Press the **NEXT** soft key to continue.

In the time display the horizontal axis is in seconds and the vertical axis is in volts.

In the frequency display the horizontal axis is in hertz and the vertical axis is in volts.

Press the right soft key to alternate between the options to **RUN** (measure and display the signal) and **HOLD** (freeze the signal).

The scope enables you to print the voltage trace to the printer when you freeze the signal. To print, select the **PRINT** soft key.

To return to the METERS menu, press **END**.

### DC AMP (requires the optional amp clamp)

The DC ammeter measures DC magnitude and flow of the DC current in a circuit.

1. Connect the amp clamp lead to the GR8's accessories port.
2. Select the meter's icon.
3. Select the amp clamp range.
  - 1  70 AMP MAX.
  - 2  700 AMP MAX.

Press the **NEXT** soft key to continue.

4. The meter will zero itself.
5. Place the clamp's jaws around the negative (-) cable.
6. The GR8 will display the measurement.
7. To return to the METERS menu, press the **END** soft key



**AC AMP (requires the optional amp clamp)**

The DC ammeter measures the magnitude and flow of the AC current through a circuit during normal operations.

1. Select the amp clamp range.
  - 1  70 AMP MAX.
  - 2  700 AMP MAX.

Press the **NEXT** soft key to continue.

2. The meter will zero itself.
3. Place the clamp's jaws around the negative (-) cable.
4. The GR8 will display the measurement.
5. To return to the METERS menu, press the **END** soft key.

**Temp**

The IR temperature sensor measures surface temperature within a range of -20 to 200°C. The tool can be used for checking the transmission for overheating, and the temperature levels of the heater and air conditioner. *Figure 12* shows how to aim the GR8's temperature sensor at a component you are testing.

**Ohm Meter**

The meter is connected in parallel with the circuit under test and uses the power supplied by the GR8's internal batteries to detect open or excessive resistance.



**CAUTION:** Always remove power from the circuit before connecting the ohmmeter to avoid damaging the analyzer.

1. Connect the DMM test lead to the GR8's accessories port.
2. Select the meter's icon.
3. Connect the clamps or probes in the correct polarity: red clamp or probe to positive (+); black to negative (-).
4. The meter will autorange and display the measurement.
5. When finished, press the **END** soft key.
6. To return to the METERS menu, press the **END** soft key.

**Diode**

This test measures the voltage drop across components, such as diodes.

1. Connect the probes test lead to the GR8's accessories port.
2. Select the meter's icon.
3. Connect the probes in the correct polarity: red clamp or probe to positive (+); black to negative (-).
4. The meter will autorange and display the measurement.
5. When finished, press the **END** soft key.

**Volts/Amp (requires the optional amp clamp)**

The volts/amp meter simultaneously measures charging voltage and charging current.

1. Connect the amp clamp lead to the GR8's accessories port.
2. Select the meter's icon.
3. Select the amp clamp range.
  - 1  70 AMP MAX.
  - 2  700 AMP MAX.

Press the **NEXT** soft key to continue.

4. The meter will zero itself and display the amperage and voltage measurements.
5. Place the clamp's jaws around the negative (-) cable.
6. Connect the battery test cable to the GR8.
7. Connect the battery test clamps in the correct polarity: red clamp or probe to positive (+); black to negative (-).
8. The GR8 will display the measurement.
9. To return to the METERS menu, press the **END** soft key.

**Multimeter Specifications**

The accuracy specification is defined as  $\pm (n\% \text{ reading} + [\text{count} * \text{resolution}])$  at 77 °F.

**Table 16: DMM Specifications**

	Range	Resolution	Accuracy	Overload Protection
<b>Vdc</b>	0–60 V	0.01 V	0.05% + 2	120 Vrms
<b>Vac</b>	0–24 Vac rms	0.01 Vac	0.1% + 3	120 Vrms
<b>Adc</b>	0–70 A	0.01 A	$\pm 3\%$ of reading $\pm 1A$	1000 Arms
	0–700 A	0.1 A	$\pm 3\%$ of reading $\pm 1A$	1000 Arms
<b>Aac</b>	0–70 A	0.01 A	$\pm 3\%$ of reading $\pm 1A$	1000 Arms
	0–700 A	0.1A	$\pm 3\%$ of reading $\pm 1A$	1000 Arms
Accuracies are specified from 2% to 100% of range.				
	Range	Resolution	Accuracy	Overload Protection
<b>Ohm</b>	10 $\Omega$ –2 M $\Omega$	1 $\Omega$	2.0% + 4	120 Vrms
<b>Continuity</b>	< 10 $\Omega$	1 $\Omega$	2.0% + 4	120 Vrms
<b>Diode</b>	0–1.5 V	0.01 V	0.05% + 2	120 Vrms
<b>Temperature</b>	-20–200 °F	1 °F	1.0% + 5	-----

## Chapter 15: Admin



This section explains how to use the Admin Utility to control password access to the GR8-1200. It also describes functions that clear test totals and restore settings to factory defaults.

Select the ADMIN icon to display a list of administrative functions:

### Clock



The CLOCK ADJUST utility has four settings. Use the UP or DOWN ARROW key to highlight the setting you want to change. Although the date and time have been set at the factory, you may want to make adjustments based your time zone or Daylight Saving Time.

```

MODE :                AM/PM
TIME :                9:07 AM
FORMAT :             MM/DD/YYYY
DATE :               11/29/2006
    
```

### Mode

Use the UP or DOWN ARROW key, or press the corresponding numerical key (1 or 2) to move the dot to the option button of your choice.

- Select the or 24-hour or 12-hour (AM/PM) clock.
  - 1  24 HOUR
  - 2  AM/PM
- If you used the ARROW keys, press the SAVE soft key to save your setting or the BACK soft key to return to the CLOCK ADJUST screen without saving the changes.

If you use the alphanumeric keypad to enter the number preceding the option button, no additional keypress is needed to save your selection.

### Time

- Use the LEFT or RIGHT ARROW keys to highlight the hour, minutes, or AM or PM. To rapidly scroll, hold down an UP or DOWN ARROW key.

```

9 : 19 PM
    
```

- Press the SAVE soft key to save your setting, or press the BACK soft key to return to the CLOCK ADJUST screen.

### Format

Use the UP or DOWN ARROW or press the corresponding numerical key (1 or 2) to move the dot to the option button of your choice.

- Select the format of the date.
  - 1  MM/DD/YYYY (month/day/year)
  - 2  DD/MM/YYYY (day/month/year)
- If you used the ARROW keys, press the SAVE soft key to save your setting or the BACK soft key to return to the CLOCK ADJUST screen without saving the changes.

If you use the alphanumeric keypad to enter the number preceding the option button, no additional keypress is needed to save your selection.

### Date

- Use the LEFT or RIGHT ARROW key to highlight the month, day, or year. To rapidly scroll, hold down an UP or DOWN ARROW key.

```

12 / 17 / 2008
    
```

- Press the SAVE soft key to save your setting or the BACK soft key to return to the CLOCK ADJUST screen without saving the changes. Users



The USERS utility allows you to create and edit a USER ID with 1 to 7 alphanumeric characters and link it to a test counter. It also allows you to delete a USER ID and its associated test total.

### Entering A New User ID

- To create a USER ID, select:
  - 1  ENTER NEW
  - 2  DELETE
  - 3  EDIT

Press the **NEXT** soft key to display the list of available IDs.

- Use the UP or DOWN ARROW keys to scroll to the ID placeholder you want to use. Scrolling past the first line displays the previous screen. Scrolling past the fourth line displays the next screen. To display more placeholders, continue scrolling or use the LEFT or RIGHT ARROW key to jump up or down through the list five lines at a time.

```

1 USER01
2 USER02
3 USER03
4 USER04
    
```

Press the **NEXT** soft key to continue.

- 3. To clear the default characters, press the LEFT ARROW key. To add a space, move the cursor forward by pressing the RIGHT ARROW key.

ENTER USER ID

USER01

- 4. Insert a character by pressing the alphanumeric key associated with the character as many times as needed. Press the SAVE soft key.

ENTER USER ID

MIKE T

**Deleting A User ID**



**NOTE:** You cannot delete placeholder USER IDs (i.e., USER03).

- 1. To delete a USER ID, select:

- 1  ENTER NEW
- 2  DELETE
- 3  EDIT

Press the NEXT soft key to display the list of IDs.

- 2. Use the ARROW keys to select a USER ID as described in step 2 in "Entering a New User ID" on the previous page.

- 1 ANDY
- 2 JIM F
- 3 USER03
- 4 USER04

Press the **DELETE** soft key to continue.

**Editing A User ID**

- 1. To edit a USER ID, select:

- 1  ENTER NEW
- 2  DELETE
- 3  EDIT

Press the NEXT soft key to display the list of IDs.

- 2. Use the ARROW keys to select a USER ID as described in step 2 in "Entering A New User ID".

- 1 ANDY
- 2 JIM F
- 3 USER03
- 4 USER04

Press the SELECT soft key to continue.

- 3. Edit the displayed User ID.
- 4. Press the SAVE button to save your changes.

**Shop**



The SHOP INFO utility allows you to create a header for your printed test results with your business location information when the Admin option 3-PRINT HEADER is selected (page 35). Its three information screens contain 12 lines of text with a maximum of 17 characters per line.

You create your own header or load one from the data card.

To manually create or overwrite a header:

- 1. Select MANUAL EDIT and press NEXT.
- 2. Press the UP or DOWN ARROW to highlight the line you want to change. The cursor blinks to the right of the last character in the line. (The cursor is not visible if all character spaces are filled.)
- 3. To erase a character, press the LEFT ARROW key.
- 4. Insert a character by pressing the alphanumeric key associated with the character as many times as needed. You can center text by inserting blank spaces with the RIGHT ARROW key. If you pause momentarily, the cursor will automatically move to the right.

**IMPORTANT:** Be sure to erase any default characters on unused lines by pressing the LEFT ARROW key.

- 5. Press the SAVE soft key to save your setting or the BACK soft key to return to the SHOP INFO screen without saving the changes.

**Table 17: Battery Ratings**

Screen 1	Screen 2
1-YOUR SHOP NAME	5-YOUR COUNTRY
2-1000 ANY ST.	6-YOUR PHONE NUMBER
3-YOUR TOWN, STATE	
4-YOUR POSTAL CODE	

To help you edit and center your header, use a pencil to write the information in the template below before entering it into the Battery Diagnostic Station.

*Header Template*

Line 1																	
Line 2																	
Line 3																	
Line 4																	
Line 5																	
Line 6																	
Line 7																	
Line 8																	

**Display**



The LCD CONTRAST utility allows you to adjust the contrast of the text on the display and the backlight time.

**Contrast Level**

The contrast level is 0 (lightest) to 10 (darkest). To change it:

1. Press the UP or DOWN ARROW key to highlight the option.



2. Press the ADJUST soft key to display the option's numerical scroll box.



3. Press the UP or DOWN ARROW key or the corresponding numerical keys to select your preference. To erase a character, press the LEFT ARROW key.
4. Press the SAVE soft key to save your setting or the BACK soft key to return to the LCD OPTIONS screen without saving the changes.

**Coupon**



The COUPON utility allows you to enable and disable the custom coupons or message created in the EDIT COUPON utility. You also have the option of having no coupon print.

1. Use the UP or DOWN ARROW key, or press the corresponding numerical key to move the dot to the option button of your choice (1 or 2).

1  NO USER COUPON PRINTED

2  USER COUPON

2. If you used the ARROW keys, press the SAVE soft key to save your setting or the BACK soft key to return to the Admin / Utility Menu without saving the changes.

If you use the alphanumeric keypad to enter the number preceding the option button, no additional keypress is needed to save your selection.

**Edit Coupon**



The EDIT COUPON utility allows you to create and store a promotional coupon or message on the printed test results you give to your customers. The utility's two information screens contain eight lines of text with a maximum of 17 characters per line. To enable and disable the inclusion of the text on your test results, use the COUPON utility.

To create and edit a coupon, see the procedure under "Shop" in this chapter for using the keypad to enter and backspace over characters.

To help you edit and center your coupon, use a pencil to write the information in the template below before entering it into the Battery Diagnostic Station.

*Coupon Template*

Line 1																			
Line 2																			
Line 3																			
Line 4																			
Line 5																			
Line 6																			
Line 7																			
Line 8																			

**Temp**



The TEMP. UNITS utility allows you to set the units of measurement to either Fahrenheit or Celsius.

To set your preference:

- Use the UP or DOWN ARROW key, or press the corresponding numerical key (1 or 2) to move the dot to the option button of your choice.
  - DEGREES F
  - DEGREES C
- If you used the ARROW keys, press the SAVE soft key to save your setting or the BACK soft key to return to the Setup Menu without saving the changes.

If you use the alphanumeric keypad to enter the number preceding the option button, no additional keypress is needed to save your selection.

**Language**



The LANGUAGE utility allows you to select a language for the display and printouts. You can override the selection when the Battery Diagnostic Station displays the language option after you turn it on or print results.

To set your preference:

- Use the UP or DOWN ARROW key or press the corresponding numerical key (1, 2, or 3) to move the dot to the option button of your choice.
  - ENGLISH
  - ESPAÑOL
  - FRANÇAIS

- If you used the ARROW keys, press the SAVE soft key to save your setting or the BACK soft key to return to the Admin / Utility Menu without saving the changes.

If you use the alphanumeric keypad to enter the number preceding the option button, no additional keypress is needed to save your selection.

**Format**



Select this utility to format a data card to receive data or erase all data on the card. The Battery Diagnostic Station will warn you before formatting the disk and ask if you want to continue.

**Update**



When software updates become available for the Battery Diagnostic Station, this utility walks you through the quick process of updating the Battery Diagnostic Station software using a data card.

**Admin**



Select the ADMIN icon to display a list of administrative functions:

Use the UP or DOWN ARROW key or press the corresponding numerical key (1, 2, or 3) to move the dot to the option button of your choice.

- OPTIONS
- CHANGE ADMIN PIN
- CLEAR TEST TOTALS
- RESET DEFAULTS

### Options

In the OPTIONS section there are four functions that allow you to control user access to the Main Menu and Admin / Utility Menu. Each option is easily enabled or disabled by turning it ON or OFF. To save your settings after each selection, press the SAVE soft key. To return to the administrative functions list without saving, press the BACK soft key.

#### 1 – USER ID

Select this setting to enable (ON) or disable (OFF) the USER ID login screen.

#### 2 – UNREG. USER

Select this setting to enable (ON) or disable (OFF) unregistered login access to the Battery Diagnostic Station.

#### 3 – PRINT HEADER

Select this setting to enable or disable printing of the header you created using the Shop Utility (page 21).

#### 4 – ADMIN PIN

Select this setting to enable (ON) password protection for ADMIN mode

#### 5 – 7 SCREEN INPUT 1-3

Select this setting to enable (ON) to display user-defined text fields

### Change Admin Pin

This function allows you to enter a new Admin Pin.

### Clear Test Totals

This function allows you to clear the test totals by User ID and battery test decision. The Battery Diagnostic Station verifies that you want the counter reset to 0 before it continues.



**NOTE:** This will not clear the lifetime test total available in the VERSION information screen.

### Reset Defaults

This function allows you to reset Administrative options to their original settings. It will clear all registered users.

**Table 18: Battery Ratings**

Option	Default Settings
1 – USER ID	ON
2 – UNREG. USER	ON
3 – PRINT HEADER	ON
4 – ADMIN PIN	OFF
5 – 7 SCREEN INPUT 1-3	OFF

### Printer



The PRINTER utility allows you to set your printer preference.

1. Use the UP or DOWN ARROW key or press the corresponding numerical key (1 or 2) to move the dot to the option button of your choice. The default is the internal printer.

1  IR PRINTER

2  INTERNAL PRINTER

2. If you used the ARROW keys, press the SAVE soft key to save your setting or the BACK soft key to return to the Admin Menu without saving the changes.

If you use the alphanumeric keypad to enter the number preceding the option button, no additional keypress is needed to save your selection.

### Buzzer



The BUZZER utility allows you to enable or disable the beep that warns you if the clamps are connected improperly and alerts you to other errors.

1. Use the UP or DOWN ARROW key or press the corresponding numerical key (1 or 2) to move the dot to the option button of your choice.

1  OFF

2  ON

2. If you used the ARROW keys, press the SAVE soft key to save your setting or the BACK soft key to return to the Admin / Utility Menu without saving the changes.

If you use the alphanumeric keypad to enter the number preceding the option button, no additional keypress is needed to save your selection.

User Screen



This utility allows you to customize screen information. Data may be entered manually or using a data card. To use a data card, insert the data card in to the data slot and select Data Card. Data will be uploaded automatically and tester will return to Utility Menu.

- 1. Select the input screen by pressing the UP or DOWN ARROW key as many times as needed:

- 1  INPUT SCREEN 1
- 2  INPUT SCREEN 2
- 3  INPUT SCREEN 3

Press the NEXT soft key to continue.

- 2. Use the UP or DOWN ARROW keys to scroll to the method for data entry you want to use.

- 1  MANUAL EDIT
- 2  DATA CARD

Press the NEXT soft key to continue.

- 3. Insert a character by pressing the alphanumeric key associated with the character as many times as needed. If you pause momentarily, the cursor will automatically move to the right.

ENTER SCREEN TITLE

Press the NEXT soft key to continue.

- 4. Use the UP or DOWN ARROW key to move to the line you want to edit.

SCREEN OPTIONS

- 1 -
- 2 -
- 3 -
- 4 -

Press the SELECT soft key to continue.

- 5. Insert a character by pressing the alphanumeric key associated with the character as many times as needed. If you pause momentarily, the cursor will automatically move to the right.

- 1 - USER OPTION LINE 1
- 2 -
- 3 -
- 4 -

Press the SAVE soft key.

## Chapter 16: Troubleshooting

Table 19: Troubleshooting

MESSAGE	Option	EXPLANATION
VOLTAGE OUT OF RANGE! VALID RANGE 0 TO 16 VOLTS	Attention light flashes at 0.5 second intervals.	Tool detects incorrect voltage in battery test.
INVALID NUMERIC ENTRY	Less than 100 CCA or invalid date entry can cause this error. Attention light flashes at .5 second intervals.	Any edit box entry that exceeds the limits.
INTERNAL MEMORY ERROR!	Attention light flashes at 0.5 second intervals	Upon power up the tool detects a checksum error
REVERSE CONNECTION! CHECK POLARITY OF SMALL CLAMPS.	At power up or when reverse connection is made. For charger this can only occur at main menu or in a charger test screen	Tool will return to state that threw the error if the connection becomes valid. For charger both the bridge and controller will sound a steady tone until the error is corrected.
CONNECT RED CLAMP TO BATTERY POSITIVE (+) POST, CONNECT BLACK CLAMP TO BATTERY NEGATIVE (-) POST!	Clamp not connected Attention light flashes at 0.5 second intervals	Tool will return to state that threw the error if the connection becomes valid
CHARGER FAULT! CHECK CLAMPS! CHECK SERIAL CABLE!	Attention light flashes at 0.5 second intervals	Charger reported a fatal error.
BATTERY POWER TOO LOW TO USE PRINTER. CONNECT TO FULLY CHARGED BATTERY TO PRINT RESULTS. 11.50V TO 16.00V	Does not print and display this message if clamps are not connected	Screen will be displayed for 3 seconds and then tool will return to viewing screen where print initiated from.



MESSAGE	Option	EXPLANATION
CHARGER ERROR IS CHARGER TURNED ON? ARE CABLES CONNECTED?	This occurs if the bridge cannot talk to the charger.	Make sure the charger is turned and the cables are connected. Also make sure the Multitasker module is receiving power and is properly connected between the Control Module and the charger.
WIRELESS ERROR IS CHARGER TURNED ON? ARE YOU WITHIN RANGE?	If Zigbee connected and message fails 4 times this error appears.	This happens from Main Menu into charge feature or when results are uploaded.
SYSTEM NOISE DETECTED	The GR8 has detected computer, ignition noise, or parasitic drain, and will attempt to retest.	<p>Make sure all vehicle loads are off, doors are closed, and the ignition is in the off position. The GR8 will automatically retest when it no longer detects system noise. If the message reappears:</p> <ul style="list-style-type: none"> <li>• You may be testing too close to a noise source, such as an arc welder or other high-current device. If so, move away and retest.</li> <li>• If you are unable to find the source of the noise, fully charge the battery and retest. If the message appears after recharging, test the battery out of the vehicle.</li> <li>• Disconnect the battery cables and retest.</li> </ul>
UNSTABLE BATTERY DETECTED	A battery that is weak, or that has just been charged, may retain enough electrical activity to be detected by the GR8 and will adversely affect the test results.	A fully charged battery should stabilize quickly, after which the GR8 will automatically retest. Weak batteries should be charged and retested. If the battery is fully charged, check the clamp connections.

## Chapter 17: Charger Maintenance

### Replacing the Paper Roll

The printer uses thermal paper in a roll with the dimensions 2.25 in x 85 ft. (57 mm x 25.9 m). You can purchase replacement rolls through a local office supply store.

### Test Cable Maintenance

Here are a few things you can do to protect your test cables from damage and premature wear:

- The grease, dirt, and sulfation that build up on battery terminals are highly corrosive and can damage the clamps over time. Before connecting the clamps, ensure accurate test readings and protect the clamps by cleaning the battery case and terminals using a wire brush and a mixture of water and baking soda.
- Periodically clean the clamps using a mixture of baking soda and water, or a mild hand-soap, and a small bristle brush.
- Clean the battery terminals. If stud adapters are required, fasten them with the proper tool. Do not use the battery clamps to tighten adapters.
- Never remove the clamps from a battery to abort an active charging session. Always press the red **STOP** button before removing the clamps.
- Do not leave the clamps laying in battery acid.
- Hang the clamps on the cable wrap on the back of the GR8 when not in use.

### Attaching the Charger Cables

The two connectors for the charger cables are located on the back of the GR8. Three screws are included to secure the cables. To attach the cables:

1. Plug in the large connector (A), then plug in the small connector (B).

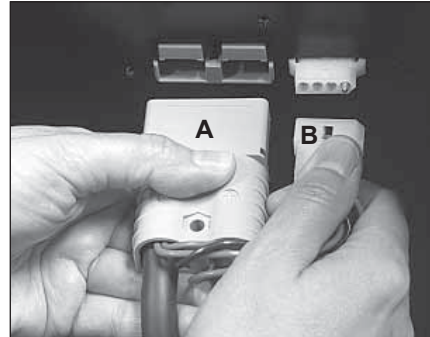

2. Slide the cover (C) down the cables until it seats against the sheet metal.

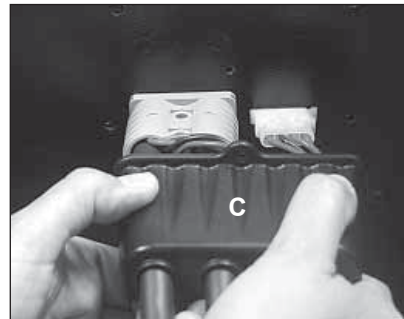

3. Insert the screws through the holes in the cover and sheet metal. Tighten the screws securely with a small screwdriver. (To remove the cables, use the attachment instructions in reverse.)

