

EXP-800

Midtronics Battery & Electrical Diagnostic Analyzer

*For testing 6 and 12-volt automotive batteries
and 12- and 24-volt charging systems*



INSTRUCTION MANUAL

Contents

Chapter 1: Before You Begin	5	Chapter 4: Admin/Utility Menu	14
Safety Reminder	5	Clock	15
Personal Precautions	5	Mode	15
Chapter 2: Overview	6	Time	15
Connections and Data Ports	6	Format	15
Connecting the Battery Test Cable	7	Date	15
Removing and Inserting the Data Card	7	Shop	16
Display and Keypad	8	Users	16
Data Entry Methods	10	Entering a New User ID	16
Menu Icons	10	Deleting a User ID	17
Option Buttons	10	Display	17
Scrolling Lists	10	Contrast Level	17
Scroll Boxes	10	Backlight Time	17
Alphanumeric Entry	10	Coupon	17
Menu Structure	11	Edit Coupon	18
Main Menu	11	Temp	18
Info Menu	11	Track Calls	18
Admin/Utility Menu	12	Language	19
Chapter 3: Getting Started	13	Admin	19
Logging In for the First Time	13	Options	19
Bootup	13	Clear Test Totals	19
Entering Your Store ID Number and Zip Code	13	Reset Defaults	19
Logging in as an Unregistered User	13	Store ID#	19
Adding a User	13	Format Disk	20
Disabling the Login Screens	13	Update	20
		Chapter 5: Test Preparation	21
		Inspecting the Battery	21
		Testing Out-of-Vehicle (Battery Test)	21
		Testing In-Vehicle (System Test)	21
		Connecting to the Battery	21

Chapter 6: Battery Test	22	Chapter 10: Printing Test Results	30
Additional Test Requirements and Messages	23	Changing the Paper in the Internal Printer	30
System Noise Detected	23		
Unstable Battery Detected	23	Chapter 11: Troubleshooting	31
Deep Scan Test	23	Problems with the Display	31
Voltage Out of Range	23	Problems with the Internal Printer	31
Battery Test Results	23		
State of Health (SOH)	24	Chapter 12: Test Cable Maintenance	32
		Cleaning the Clamps	32
Chapter 7: System Test	25	Handling the Test Cables	32
Battery Test	25	Storing Test Cables	32
Starter System Test	25	Testing Resistance in the Cable Set	33
Charging System Test	26	Test Procedure	33
Chapter 8: PDI Battery Test	28	Chapter 13: EXP Internal Batteries	34
Selecting Test Parameters	28	Battery Power Indicator	34
Printing Test Results	28	Replacing the Internal Batteries	34
When the EXP displays a total of 100 Tests	28		
Chapter 9: Info Menu	29		
View Test	29		
View PDI Test	29		
Totals	29		
Transfer	29		
Version	29		

Chapter 1: Before You Begin



Safety Reminder

For safe, efficient, and accurate testing, review the safety and operating instructions in this manual before using the analyzer. In addition, follow all manufacturers' instructions and BCI (Battery Council International) safety recommendations.



Personal Precautions

Inspect the battery for damages and check the electrolyte level. If the electrolyte level is too low, replenish it and fully charge the battery. Always use the necessary safety precautions when working with batteries to prevent severe injury or death. Follow all manufacturers' instructions and BCI (Battery Council International) safety recommendations, which include the following precautions:

▮ **DANGER—RISK OF EXPLOSIVE GASES:** Batteries can produce a highly explosive mix of hydrogen gas and oxygen, even when the battery is not in operation. Always work in a well-ventilated area. Never smoke or allow a spark or flame in the vicinity of a battery.

▮ **WARNING—REQUIRED BY CALIFORNIA PROP. 65:** Battery posts, terminals, and related accessories contain lead and lead compounds, chemicals known to the state of California to cause cancer and birth defects or other reproductive harm. Wash hands after handling.

▮ Battery acid is highly corrosive. If acid enters your eyes, immediately flush them thoroughly with cold running water for at least 15 minutes and seek medical attention. If battery acid gets on your skin or clothing, wash immediately with a mixture of water and baking soda.

▮ Always wear proper safety glasses or face shield when working with or around batteries.

▮ Keep hair, hands, and clothing as well as the analyzer cords and cables away from moving engine parts.

▮ Remove any jewelry or watches before you start servicing the battery.

▮ Use caution when working with metallic tools to prevent sparks or short circuits.

▮ Never lean over a battery when testing, charging, or jump starting.

Chapter 2: Overview

This chapter describes the analyzer's hardware and software interface. The components include test leads and connectors, and the display and keypad. The user interface comprises the software menus, test options, and utilities.

Connections and Data Ports



- 1 Integrated thermal printer
- 2 Release lever for door to paper compartment
- 3 Paper slot
- 4 LCD screen with Main Menu
- 5 Control Panel: keypad and power button
- 6 6-pin connector for the battery test cable (see the next page for detail)
- 7 Spring-loaded data card slot for test data storage and software upgrades.
- 8 Infrared temperature sensor with a range of -28°C to +93°C (-20°F to +200°F).
- 9 Data transmitter: sends test results to a PC using an optional hardware and software kit



Connecting the Battery Test Cable



CAUTION: To prevent damage to the analyzer's circuitry, do not connect the analyzer to a voltage source greater than 30 Vdc.

To connect the battery test cable to the analyzer align the arrow on the cable connector with the arrows on the analyzer's housing. Hold the part of the cable connector as shown and firmly insert the connector into analyzer's six-pin receptacle.

Do not twist.

To avoid damaging the battery test cable, always hold the ridged part of the cable connector (as shown in the photo) when inserting and removing the cable.

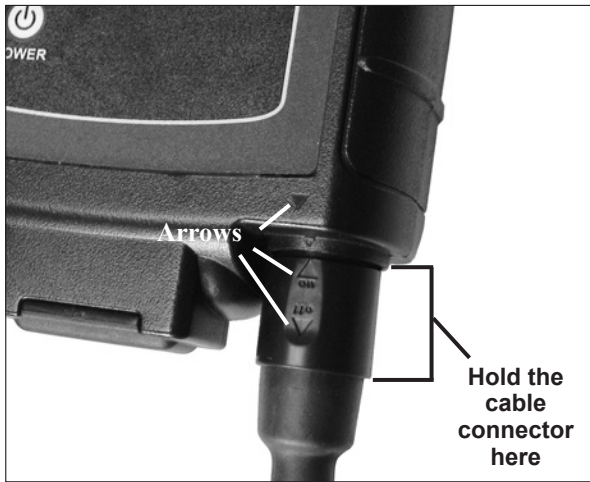

Removing and Inserting the Data Card

The analyzer ships with a plastic insert in the data card slot to protect it from dust and debris. To remove the plastic insert or a data card, push briefly on its edge to release it and pull it from the slot.

When inserting a card, push it into the slot until it locks. The card is correctly inserted when it is not protruding from the slot. To protect the card slot and enable the analyzer to read and write to the card, leave the card in the slot.

Display and Keypad

The EXP display and keypad work together to help you quickly find and use the right tools at the right time. The display also keeps you on track with on-screen navigation aids, directions, and messages. The illustration shows how the elements on the screen relate to the keypad.

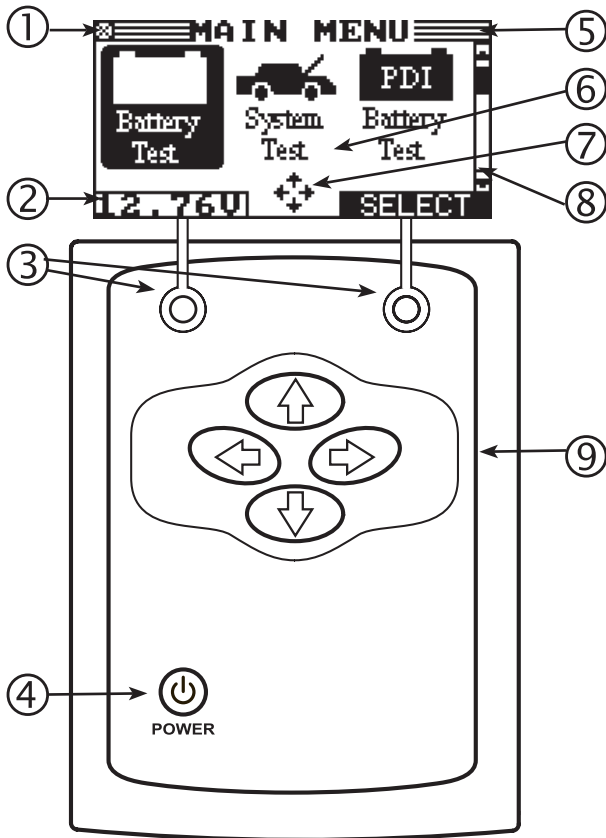

1 Internal Batteries Status Indicator

This indicator appears in the screen's top left corner, lets you know the status and charge level of the analyzer's six 1.5-volt batteries. The **X** in the top left corner of the screen shows that the analyzer is powered by the battery you're testing to conserve the analyzer's internal batteries.

2 Voltmeter

When you first connect the analyzer to a battery it functions as a voltmeter. The voltage reading appears above the left soft key until you move to other menus or functions.

3 Soft Keys

Press the two **Soft Keys** linked to the bottom of the screen to perform the functions displayed above them. The functions change depending on the menu or test process. So it may be helpful to think of the words appearing above them as part of the keys. Some of the more common soft-key functions are **SELECT**, **BACK**, and **END**.

4 POWER Key

Press the **POWER** button to turn the analyzer on and off. The analyzer also turns on automatically when you connect its test leads to a battery.

5 Title Bar

The title bar shows you the name of the current menu, test tool, utility, or function.

6 Selection Area

The selection area below the Title Bar contains selectable items or dialog boxes that display information or require a response.

7 Menu Screen Arrows

When displayed in menu screens, the menu screen arrows show you which **ARROW** key on the keypad to press to display other icons or screens. The Up and Down Menu Screen Arrows, for example, indicate when to press the **UP** (**▲**) and **DOWN** (**▼**) **ARROW** keys to display the screens above and below the current screen.

The Left and Right Menu Screen Arrows tell you when to use the **LEFT** (**◀**) or **RIGHT** (**▶**) **ARROW** keys to select an icon.

When displayed under a list of options, the menu screen arrows show you which keypad arrow to press to highlight a character or item in a list.

8 Scroll Bar

Another navigational aid is the scroll bar on the right side of the screen. The position of its scroll box shows you whether the screen is the top (or only screen), middle, or last in a series.

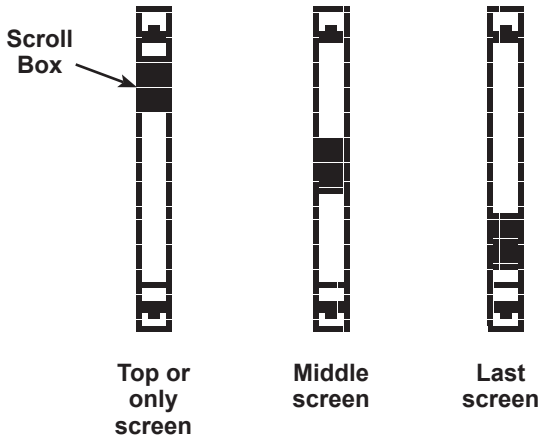

9 ARROW keys

Press the **UP ARROW** key to move up to the next selectable item or row. When entering text, use the **UP ARROW** key to move to the previous character.

Press the **DOWN ARROW** key to move down to the next selectable item or row. When entering text, use the **DOWN ARROW** key to move to the next available character.

Use the **UP** and **DOWN ARROW** keys to scroll to the letters A through Z, numbers 0 through 9, and the following symbols:

! " # \$ % & ' () * + , - . / : ; < = > ? @

When entering text, use the **RIGHT ARROW** key to move one space to the right.

Use the **LEFT ARROW** key to move one space to the left.

Data Entry Methods

To perform a particular test or function, the EXP requires different types of information. This means that the methods you use to enter information will change depending on the type of information requested. The five types of entry methods are described below.

Typically, the soft key below the right half of the screen confirms your choice, although the command above it may vary. (Examples: **SELECT**, **NEXT**, and **SAVE**.) In a similar fashion, the soft key below the left half of the screen cancels your choice or returns you to the previous screen, although the word above it may also vary. (Examples: **BACK** and **END**.)

Menu Icons

A menu icon is a graphical representation of a function you can select, such as the Battery test icon in the Main Menu. To select an icon, use the **LEFT ARROW** or **RIGHT ARROW** key to highlight it. Highlighting changes the icon to a white picture on a black background. To confirm your selection, press the appropriate soft key.



Option Buttons

Some lists have option buttons before each item. To select an item, use the **UP** or **DOWN ARROW** key to move the dot to the button next to the item. To confirm your selection, press the appropriate soft key.



Scrolling Lists

Scrolling lists contain items that extend above and below the screen. The first number above the right soft key indicates the position in the list of the highlighted item. The second number above the right soft key indicates the number of items in the list.

To select an item, press the **UP** or **DOWN ARROW** key to highlight the item and press the appropriate soft key.

To move the highlight bar up four lines at a time, press the **LEFT ARROW** key.

To move the highlight bar down four lines at a time, press the **RIGHT ARROW** key.



Scroll Boxes

Scroll boxes contain variables that are displayed by scrolling using arrow keys.

To select, use the **UP** or **DOWN ARROW** key to scroll to the value, and press the appropriate soft key. In the illustration the left directional arrow indicates that you can press the **LEFT ARROW** key to clear all or part of the entry.)



Alphanumeric Entry

Some selections require you to alphanumeric characters. These "user-defined" selections have a blinking horizontal line (cursor) to the right of the last character.

Use the **UP** or **DOWN ARROW** keys to highlight a line for editing. Press the **SELECT** soft key to edit the selected line. Display the character or number you want by rapidly pressing an **ARROW** key as many times as needed, or press and hold the **ARROW** key to rapidly scroll. To backspace, press the **LEFT ARROW** key. Use the **RIGHT ARROW** key to add a space. When finished, press the appropriate soft key to save the text you entered.









Menu Structure

This section contains a graphical representation of the menu structure with brief descriptions of the utilities in each menu.





Main Menu

The Main Menu is the starting point for all tools and utilities, which are depicted as icons. Some icons lead directly to the function they represent, while others are menu icons that lead to two or more options. Menu icons marked with an asterisk (*) are mapped on the following pages.

Menu Icon	Description
 Battery Test	Tests a battery using the battery information you select in a series of screens.
 System Test	Tests a battery, and the starting and charging systems.
 FDI Battery Test	Enables you to test up to 100 batteries in succession without re-entering battery information each time. Frees up inventory space by weeding out defective batteries.
 *	Utility to view and print test results, a test counter, a data transfer utility, and information on the analyzer software version and serial number.
 *	Provides access to the Utility Menu, which allows you to customize the analyzer and administrative functions that include setting passwords.
 Help	Provides tips for troubleshooting problems with the printer, the cables, and loss of power. Also includes Midtronics Customer Service phone numbers.













Info Menu

The Info Menu has utilities to allow you to view and print test results, track the usage and history of your analyzer, and manage test data.

Menu Icon	Description
 View Test	Displays the last battery test results. Sends the results to the internal printer.
 Totals	Reports menu that includes the following type of test totals: Battery, System, Totals by User ID, and Totals by Decision
 Transfer	A future optional accessory consists of an IR software and hardware package that will enable you to transfer test data to a PC.
 View FDI Batt Test	View and print the results of the last test of new batteries in inventory.
 Version	Displays the software version, and the serial number.

Admin/Utility Menu

The Admin/Utility Menu lets you customize your analyzer for your needs. Before using the analyzer for the first time, check the default values to see what options you may want to change, add, or delete.

Menu Icon	Description
 Clock	Settings to adjust the date and time.
 Shop	Allows you to add a custom header to printed test results.
 Users	Add, edit, or delete User IDs.
 Display	Settings to adjust the screen contrast and backlight time.
 Coupon	If you've created a coupon in the Edit Coupon utility, use Coupon to enable or disable.
 Edit Coupon	Allows you to create and store up to three separate coupons to be printed on test results.
 Temp	Allows you to select degrees in C or F for temperature measurements.
 Track Calls	Stores test results on the data card when enabled (ON).
 Language	Sets the language of the display and printouts.
 Admin	Allows you to enable or disable the user login screen, clear test totals, address header printing and restore defaults.
 STORE ID#	Allows you to change your store ID number and includes the number on printed results.
 Format	Formats the data card to receive data. Also erases all data on the card.
 Update	Updates the analyzer software via files on a data card.

Chapter 3: Getting Started

The EXP is initially set up to require a default USER ID to access the Main Menu. The instructions in this section show you how to log in for the first time, enter your store ID and zip code (required only once), and adjust optional settings.

Logging In for the First Time

When you turn on the EXP, it takes approximately eight seconds to boot up while testing the integrity of its software.

Bootup

The first selection screen to appear enables you to set the language for the display and printed test results. You can disable this option in the Admin/Utility Menu. See “Options” on page 19.

- Use the **UP** or **DOWN ARROW** key to move the dot to the option button of your choice (1, 2, or 3).
 - ENGLISH
 - ESPAÑOL
 - FRANÇAIS
- Press the **NEXT** soft key to continue.

Entering Your Store ID Number and Zip Code

The next screen asks you to enter your store ID number.

- Display a number by pressing the **UP** or **DOWN ARROW** key as many times as needed.

ENTER STORE ID#

- Press the **NEXT** soft key to continue.
- Use the **UP** or **DOWN ARROW** key to enter your store’s zip code.

ENTER ZIP CODE

- Press the **NEXT** soft key to continue.

The next time you log in, you will not be asked for your store ID and zip code. The analyzer saves stores them in memory until you change them using the STORE ID# option in the Admin/Utility Menu.

Logging in as an Unregistered User

The default setting requires a user name to display the Main Menu. You can log in as an unregistered user or you can create a new user ID.

To log in as an unregistered user, press the **NEXT** soft key to selected the highlighted UNREG.

0 UNREG

1 ADD USER

Adding a User

- Use the **DOWN ARROW** key to scroll to ADD USER. Press the **NEXT** soft key to continue.

0 UNREG

1 ADD USER

- Use the **UP** or **DOWN ARROW** key to scroll to the ID placeholder you want to use. Scrolling past the first line displays the previous screen. Scrolling past the fourth line displays the next screen. To display more placeholders, continue scrolling or use the **LEFT** or **RIGHT ARROW** key to jump up or down through the list five lines at a time. Press the **NEXT** soft key to continue.

1 USER01

2 USER02

3 USER03

4 USER04

- To clear the default characters, press the **LEFT ARROW** key. To add a space, move the cursor forward by pressing the **RIGHT ARROW** key.

ENTER USER ID

USER01

- Display a character by pressing **UP** or **DOWN ARROW** key as many times as needed. Press the **SAVE** soft key.

ENTER USER ID

DAN L

Disabling the Login Screens

You can disable and enable the login screens in the Admin/Utility Menu. See “Options” on page 19.

Chapter 4: Admin/Utility Menu

The Admin/Utility Menu has several utilities that customize the EXP—from the language of the user interface to the contrast of the text on the display. The utilities have default settings that you can change, depending on your requirements. The most important function is the ADMIN (administrative) function, which controls user access.

Table 1: Utility Default Settings

Setup Function	Default Settings
CLOCK TIME MODE DATE FORMAT	The current Central Standard Time AM Current MM/DD/YYYY (month/day/year)
SHOP	Generic header for printouts with 12 lines of text and a maximum of 17 characters per line
USERS	USER01 through USER48 are placeholder IDs used to create user names.
DISPLAY CONTRAST LEVEL BACKLIGHT TIME	Range: 0 (lightest) to 10 (darkest). The default is set at 9. Range: 0 to 60 seconds. The default is set at 15 seconds.
COUPON	Disabled (NO COUPON PRINTED)
EDIT COUPON	Eight lines of text with 17 characters per line. Default: USER COUPON LINE 1 through USER COUPON LINE 8
TEMPERATURE	DEGREES F (Fahrenheit)
TRACK CALLS	Tracking OFF
LANGUAGE	English (French-Canadian and Spanish are available). You can select the language when the EXP boots up and when you print test results.
ADMIN OPTIONS 1-USER ID 2-UNREG. USER 3-PRINTER HEADER 4-ADMIN PIN 5-DATE CODE 6, 7, 8-SCREEN INPUT	User login screen enabled (ON) Unregistered user accessibility enabled (ON) Prints address header (OFF) Administrator PIN enabled (OFF) Require battery date code (OFF) Display user-defined text fields (OFF)

Clock



The CLOCK ADJUST utility has four settings. Use the **UP** or **DOWN ARROW** key to highlight the setting you want to change. Although the date and time have been set at the factory, you may want to make adjustments based your time zone or Daylight Saving Time.

MODE :	AM/PM
TIME :	9:07 AM
FORMAT :	MM/DD/YYYY
DATE :	11/29/2006

Mode

Use the **UP** or **DOWN ARROW** key to move the dot to the option button of your choice (1 or 2).

- Select the 24-hour or 12-hour (AM/PM) clock.
 - 24 HOUR
 - AM/PM
- Press the **SAVE** soft key to save your setting or the **BACK** soft key to return to the CLOCK ADJUST screen without saving the changes.

Time

- Use the **LEFT** or **RIGHT ARROW** keys to highlight the hour, minutes, or AM or PM. To rapidly scroll, hold down an **UP** or **DOWN ARROW** key.

9 : 19 PM

- Press the **SAVE** soft key to save your setting, or press the **BACK** soft key to return to the CLOCK ADJUST screen.

Format

Use the **UP** or **DOWN ARROW** to move the dot to the option button of your choice (1 or 2).

- Select the format of the date.
 - MM/DD/YYYY (month/day/year)
 - DD/MM/YYYY (day/month/year)
- Press the **SAVE** soft key to save your setting or the **BACK** soft key to return to the CLOCK ADJUST screen without saving the changes.

Date

- Use the **LEFT** or **RIGHT ARROW** key to highlight the month, day, or year. To rapidly scroll, hold down an **UP** or **DOWN ARROW** key.

6 / 17 / 2005

- Press the **SAVE** soft key to save your setting or the **BACK** soft key to return to the CLOCK ADJUST screen without saving the changes.

Shop



The SHOP INFO utility allows you to create a header for your printed test results with your business location information. Its three information screens contain 12 lines of text with a maximum of 17 characters per line.

To create or overwrite a header:

1. Press the **UP** or **DOWN ARROW** to highlight the line you want to change. Press the **SELECT** soft key to edit the selected line. The cursor blinks to the right of the last character in the line. (The cursor is not visible if all character spaces are filled.)

2. To erase a character, press the **LEFT ARROW** key.
3. Display a character by pressing the **UP** or **DOWN ARROW** key as many times as needed. You can center text by inserting blank spaces with the **RIGHT ARROW** key.

IMPORTANT: Be sure to erase any default characters on unused lines by pressing the **LEFT ARROW** key.

4. To save your text on the selected line, press the **SAVE** soft key.



NOTE: The right soft key displays **SELECT** when you highlight a line for editing and **SAVE** when you edit the line. To exit the edit mode of the selected line without saving the changes, press the **BACK** soft key.

Screen 1	Screen 2
1-YOUR SHOP NAME —	5-YOUR COUNTRY —
2-1000 ANY STREET	6-YOUR PHONE NUMBER
3-YOUR TOWN, STATE	
4-YOUR ZIP CODE	

To help you edit and center your header, use a pencil to write the information in the template below before entering it into the EXP.

Header Template

Line 1																	
Line 2																	
Line 3																	
Line 4																	
Line 5																	
Line 6																	
Line 7																	
Line 8																	

Users



The USERS utility allows you to create and edit a USER ID with 1 to 7 alphanumeric characters and link it to a test counter. It also allows you to delete a USER ID and its associated test total.

Entering a New User ID

1. To create a USER ID, select:
 - 1 ENTER NEW
 - 2 DELETE
 - 3 EDIT

Press the **NEXT** soft key to display the list of available IDs.

2. Use the **UP** or **DOWN ARROW** keys to scroll to the ID placeholder you want to use. Scrolling past the first line displays the previous screen. Scrolling past the fourth line displays the next screen. To display more placeholders, continue scrolling or use the **LEFT** or **RIGHT ARROW** key to jump up or down through the list five lines at a time.

1 USER01
2 USER02
3 USER03
4 USER04

Press the **NEXT** soft key to continue.

- To clear the default characters, press the **LEFT ARROW** key. To add a space, move the cursor forward by pressing the **RIGHT ARROW** key.

ENTER USER ID

USER01

- Display a character by pressing the **UP** or **DOWN ARROW** key as many times as needed. Press the **SAVE** soft key.

ENTER USER ID

DAN L

Deleting a User ID



NOTE: You cannot delete placeholder USER IDs (i.e., USER03).

- To delete a USER ID, select:

- ENTER NEW
- DELETE
- EDIT

Press the **NEXT** soft key to display the list of IDs.

- Use the **ARROW** keys to select a USER ID as described in step 2 in *Entering a New User ID*.

1 ANDY

2 JIM F

3 USER03

4 USER04

Press the **DELETE** soft key to continue.

Display



Display

The LCD OPTIONS utility allows you to adjust the contrast of the text on the display and the backlight time.

Contrast Level

The contrast level is 0 (lightest) to 10 (darkest). To change it:

- Press the **UP** or **DOWN ARROW** key to highlight the option.

CONTRAST LEVEL 10

BACKLIGHT TIME 60

- Press the **ADJUST** soft key to display the option's numerical scroll box.

9 (1-10)

- Press the **UP** or **DOWN ARROW** key to select your preference. To erase a character, press the **LEFT ARROW** key.
- Press the **SAVE** soft key to save your setting or the **BACK** soft key to return to the LCD OPTIONS screen without saving the changes.

Backlight Time

Backlight time is from 0 to 30 seconds. To change it:

- Press the **UP** or **DOWN ARROW** key to highlight the option.

CONTRAST LEVEL 10

BACKLIGHT TIME 60

- Press the **ADJUST** soft key to display the option's numerical scroll box.

15 SEC

- Press the **UP** or **DOWN ARROW** key to select your preference. To erase a character, press the **LEFT ARROW** key.
- Press the **SAVE** soft key to save your setting or the **BACK** soft key to return to the LCD OPTIONS screen without saving the changes.

Coupon



Coupon

The COUPON utility allows you to enable and disable the custom coupons or message created in the EDIT COUPON utility. You also have the option of having no coupon print.

- Use the **UP** or **DOWN ARROW** key to move the dot to the option button of your choice (1 or 2).

1 NO COUPON PRINTED

2 USER COUPON

- Press the **SAVE** soft key to save your setting or the **BACK** soft key to return to the Utility Menu without saving the changes.

Edit Coupon



The EDIT COUPON utility allows you to create and store a promotional coupon or message on the printed test results you give for your customers. The utility's two information screens contain eight lines of text with a maximum of 17 characters per line. To enable and disable the inclusion of the text on your test results, use the COUPON utility.

To create and edit a coupon, see the procedure under "Shop" in this chapter for using the keypad to enter and backspace over characters.

To help you edit and center your coupon, use a pencil to write the information in the template below before entering it into the analyzer.

Coupon Template

Line 1																			
Line 2																			
Line 3																			
Line 4																			
Line 5																			
Line 6																			
Line 7																			
Line 8																			

Temp



The TEMP. UNITS utility allows you to set the units of measurement to either Fahrenheit or Celsius. To set your preference:

- Use the **UP** or **DOWN ARROW** key to move the dot to the option button of your choice (1 or 2).
 - DEGREES F
 - DEGREES C
- Press the **SAVE** soft key to save your setting or the **BACK** soft key to return to the Admin/Utility Menu without saving the changes.



NOTE: To avoid corrupting the file, copy rather than move the file to your PC.

The default setting for the utility is OFF. To set your preference:

- Use the **UP** or **DOWN ARROW** key to move the dot to the option button of your choice (1 or 2).
 - TRACKING OFF
 - TRACKING ON
- Press the **SAVE** soft key to save your setting or the **BACK** soft key to return to the Utility Menu without saving the changes.



NOTE: Over time disk access slows as the format card reaches its capacity. To free up card space, transfer the files to a PC and reformat the card to permanently erase data no longer needed.

Track Calls



The TRACK CALLS utility stores the test results and test codes by date as an .xml (Extensible Markup Language) file in a folder named "XML" on the data card before the EXP prints the results. This utility requires a data card reader (not included) to read or transfer the file to a PC. You can open the file in Microsoft® Internet Explorer®. The data in the file is separated by tags (identifiers enclosed in angle brackets) that define the data.

Language



The LANGUAGE utility allows you to select a language for the display and printouts. You can override the selection when the EXP displays the language option after you turn it on or print results.

To set your preference:

1. Use the **UP** or **DOWN ARROW** key to move the dot to the option button of your choice (1, 2, or 3).
 - 1 ENGLISH
 - 2 ESPAÑOL
 - 3 FRANÇAIS
2. Press the **SAVE** soft key to save your setting or the **BACK** soft key to return to the Admin/Utility Menu without saving the changes.

Admin



This section explains how to use the Admin Utility to control User ID access to the EXP. It also describes functions that clear test totals and restore settings to factory defaults.

Select the ADMIN icon to display a list of administrative functions:

- 1 OPTIONS
- 2 CLEAR TEST TOTALS
- 3 RESET DEFAULTS

Options

In the OPTIONS section there are three functions that allow you to control user access to the Main Menu and Admin/Utility Menu. Each option is easily enabled or disabled by turning it ON or OFF. To save your settings after each selection, press the **SAVE** soft key. To return to the administrative functions list without saving, press the **BACK** soft key.

1 – USER ID

Select this setting to enable (ON) or disable (OFF) the USER ID login screen.

2 – UNREG. USER

Select this setting to enable (ON) or disable (OFF) unregistered login access to the analyzer when option **1 – USER ID** is ON.

3 – PRINT HEADER

Select this setting to enable (ON) or disable (OFF) the address header on the printout.

4 – LANGUAGE

Select this setting to enable (ON) or disable (OFF) the language selection option when the EXP boots up.

5 – DATE CODE

Select this setting to enable (ON) to require the entry of a battery date code

6, 7, 8 – SCREEN INPUT

Select this setting to enable (ON) to display user-defined text fields

Clear Test Totals

This function allows you to clear the test totals by User ID and battery test decision. The analyzer verifies that you want the counter reset to 0 before it continues.



NOTE: This will not clear the lifetime test total available in the VERSION information screen.

Reset Defaults

This function allows you to reset Administrative options to their original settings. It will clear all registered users and restrict access to the EXP.

Option	Default Settings
1 – USER ID	ON
2 – UNREG. USER	ON
3 – PRINT HEADER	OFF
4 – LANGUAGE	ON
5 – DATE CODE	OFF
6, 7, 8 – SCREEN INPUTS	OFF

Store ID#



The next screen asks you to enter your store ID number.

1. Insert a character by pressing the **UP** or **DOWN ARROW** key as many times as needed.

ENTER STORE ID#

2. Press the **NEXT** soft key to continue.
3. Use the **UP** or **DOWN ARROW** key to enter your store's zip code, and press the **SAVE** soft key.

ENTER ZIP CODE

Format Disk



Format

Select this utility to format an data card to receive data or erase all data on the card. The analyzer will warn you before formatting the disk and ask if you want to continue.

Update



Update

When software updates become available for the EXP, this utility walks you though the quick process of updating the analyzer's software using a data card.

Chapter 5: Test Preparation

Inspecting the Battery

Before starting the test visually inspect the battery for:

- Cracked, buckled, or leaking case. If you see any of these defects, replace the battery.
- Corroded, loose, or damaged cables and connections. Repair or replace them as needed.
- Corrosion on the battery terminals, and dirt or acid on the case top. Clean the case and terminals using a wire brush and a mixture of water and baking soda.
- Low electrolyte level. If the electrolyte level is too low, add distilled water to fill up to 1/2 above the top of the plates and fully charge the battery. Do not overfill.
- Corroded or loose battery tray and hold-down fixture. Tighten or replace as needed.

Testing Out-of-Vehicle (Battery Test)

The preferred battery test location is in the vehicle. However, if you plan to test out of the vehicle:

- Always disconnect the negative cable from the battery first and reconnect it last.
- Always use a carry tool or strap to lift and transport the battery.



CAUTION: When testing side-post or Group 31 batteries, always use lead terminal adapters provided with the EXP—do not test at the battery's steel bolts. To avoid damage, never use a wrench to tighten the adapters more than 1/4 turn. Failure to properly install lead terminal adapters, or using adapters that are dirty or worn, may cause false test results.

Testing In-Vehicle (System Test)

Before starting the test, inspect the alternator drive belt. A belt that is glazed or worn, or lacks the proper tension, will prevent the engine from achieving the rpm levels needed for the test.

The preferred test position is at the battery posts. If you must test at a remote-post location, it should have both a positive and negative post. Otherwise, you must remove the battery and perform a System Test.

At the start of the test, place the vehicle transmission in PARK, make sure all vehicle accessory loads are off, the key is not in the ignition, and the doors are closed.

Connecting to the Battery

Connect the red clamp to the positive (+) terminal and the black clamp to the negative (-) terminal.

If you connect the clamps in the wrong polarity (red to negative or black to positive), the analyzer displays CLAMPS REVERSED! Reconnect the clamps.

To make sure both sides of the clamps are gripping the terminals, rock the each clamp back and forth. A poor connection will prevent testing, and the analyzer displays the message CHECK CONNECTION. If the message reappears after you have correctly reconnected the clamps, clean the terminals and reconnect

Chapter 6: Battery Test

The Battery Test analyzes a battery not connected to a vehicle. The EXP guides you through the steps of selecting your battery test parameters and interpreting the results. Before you start the test, review the instructions in Chapter 5: Test Preparation on page 21.

IMPORTANT: When you start a new test, the last test results in memory are overwritten. Remember to record or print the results if you need to retain them.

If you use the **ARROW** keys to select option buttons, press the **NEXT** soft key to continue to the next step.

1. In the Main Menu select the Battery test icon.

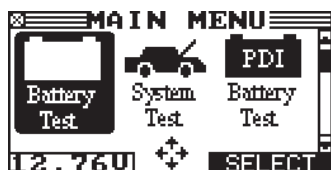

2. Use the **UP** or **DOWN ARROW** key to enter the battery date code, which is printed on the battery label. Enter the date in the format MM/YY (for example, 01/06 for January 2006) and press **NEXT**. If the date code is unavailable, press **NEXT** to continue.

IF AVAILABLE, ENTER

THE BATTERY DATE CODE

NEXT IF UNKNOWN

MM/YY

3. Select the location of the battery.
 - 1 OUT OF VEHICLE (not connected to the vehicle)
 - 2 IN VEHICLE (connect to the vehicle)

Press the **NEXT** soft key to continue.

4. Select the POST TYPE. The REMOTE option appears for the IN VEHICLE test.
 - 1 TOP POST
 - 2 SIDE POST
 - 3 JUMP START POST (appears for System Test)

Press the **NEXT** soft key to continue.

5. Select the BATTERY TYPE.
 - 1 AUTOMOTIVE (default)
 - 2 MARINE BATTERY
 - 3 MOTORCYCLE
 - 4 GROUP31
 - 5 COMMERCIAL_4D/8D
 - 6 LAWN & GARDEN

Press the **NEXT** soft key to continue.

If you select MOTORCYCLE as the battery type, the analyzer asks for the battery part number. Scroll to the part number (128 available). To increase your scrolling speed, hold the **UP** or **DOWN ARROW** key, or use the **LEFT** or **RIGHT ARROW** key to move up or down four part numbers at a time. Press **ENTER** and continue the test at step 7 to determine the battery temperature.

6. If you selected AGM as the battery type in step 5, select the type of plate construction.
 - 1 REGULAR FLOODED
 - 2 AGM
 - 3 AGM SPIRAL
 - 4 GEL

Press the **NEXT** soft key to continue.

7. Select the battery's rating units. The rating units and rating information required in the next step are printed on the battery label. If the information is unreadable, contact the battery manufacturer.
 - 1 CCA
 - 2 CA
 - 3 MCA
 - 4 JIS
 - 5 DIN
 - 6 SAE
 - 7 IEC
 - 8 EN

Press the **NEXT** soft key to continue.

Table 2: Battery Rating Systems

Rating System	Description	Range
CCA	Cold Cranking Amps (specified by SAE): The amount of current a battery can provide at 0 °F (-17.8 °C).	100 to 3000
CA	Cranking Amps: The amount of current a battery can provide at 32°F (0 °C).	100 to 3000
MCA	Marine Cranking Amps: The amount of current a battery can provide at 32°F (0 °C).	100 to 3000
JIS	Japanese Industrial Standard: (shown on a battery as a combination of numbers and letters).	72 numbers from 26A17 to 245H52
DIN (A)	Deutsche Industrie-Norm	100 to 1000
SAE (A)	European labeling of CCA	100 to 3000
IEC (A)	International Electrotechnical Commission	100 to 1000
EN (A)	Europa-Norm	100 to 1700

8 Press an **UP or DOWN ARROW** key to select the BATTERY RATING. Press **ENTER**.

If you select JIS, the analyzer asks for the JIS part number. Scroll to the part number. To increase your scrolling speed, hold the **UP or DOWN ARROW** key, or use the **LEFT or RIGHT ARROW** key to move up or down four part numbers at a time. Press **ENTER** to continue.

9. Hold the analyzer two inches above the battery case so that the IR temperature sensor on the underside of the EXP can approximate the battery temperature. Press **NEXT** to continue.

Additional Test Requirements and Messages

For a more decisive result the analyzer may ask for additional information or further explore the battery's condition. The following messages and instructions may appear before the analyzer displays the results.

System Noise Detected

The analyzer has detected computer, ignition noise, or parasitic drain, and will attempt to retest. Make sure all vehicle loads are off, doors are closed, and the ignition is in the off position. The analyzer will automatically retest when it no longer detects system noise. If the message reappears:

- You may be testing too close to a noise source, such as a charger or other high-current device. If so, move away and retest.
- If you are unable to find the source of the noise, fully charge the battery and retest. If the message appears after recharging, test the battery out of the vehicle.
- Disconnect the battery cables and retest.

Unstable Battery Detected

A battery that is weak or that has just been charged may retain enough electrical activity to be detected by the analyzer and will adversely affect the test results. A fully charged battery should stabilize quickly, after which the analyzer will automatically retest. Weak batteries should be charged and retested. If the battery is fully charged, check the clamp connections.

Deep Scan Test

In some cases the analyzer may need conduct a Deep Scan Test for a few seconds to determine whether the battery should be replaced or if it has a chance to be recovered.

Voltage Out of Range

The analyzer has detected two 12-volt batteries connected in series. Disconnect the batteries and test them individually.

Battery Test Results

IMPORTANT: To print results the EXP must be connected to a battery measuring 11.50 to 16.00 volts.

The EXP prints the results before displaying the battery decision with an analysis in a series of screens. The analysis includes the battery state-of-health (SOH). See Table 3 on the next page for an explanation of the battery decisions.



NOTE: When the option TRACK CALLS is enabled, the EXP writes the results to the data card.

Use the **UP or DOWN ARROW** key to scroll to each screen. To return to the Main Menu, press the **END** soft key. If you are performing a System Test, press the **NEXT** key to continue with the Starter System Test.

The first screenshot shows a 'RESULTS' screen with the following data: **REPLACE BATTERY**, VOLTAGE: 12.43V, MEASURED: 137 CCA, RATED: 550 CCA, TEMPERATURE: 69°F. Labels point to 'Battery decision' (REPLACE BATTERY), 'Measured voltage' (12.43V), 'Battery temperature' (69°F), 'Measured CCA' (137 CCA), and 'Selected rating' (550 CCA).

The second screenshot shows a 'RESULTS' screen with 'TEST CODE' and '11H421RP9AC0S7'. A label points to 'Test Code for all decisions'.

The third screenshot shows a 'RESULTS' screen with 'EXPECTED CHARGE TIME IS XXX MINUTES AT 40 AMPS'. A label points to 'Estimated charge time if charging needed'.

The fourth screenshot shows a 'RESULTS' screen with 'STATE OF HEALTH' and a gauge showing a needle pointing towards the right side of the scale. A label points to 'State of Health'.

State of Health (SOH)

The battery's state of health represents its general condition, and therefore its ability to deliver the specified performance compared with a fresh battery.

Although a poor state-of-health can be the result of defects in construction, it is most often caused by normal wear, which depends on vehicle needs, climate, and operating conditions. These cause irreversible physical and chemical changes within the battery until it can no longer hold a charge and supply the power to start the car and provide auxiliary power to the electrical system.

As the battery approaches end of life, its deterioration accelerates until it finally fails to start the vehicle. Before failing, the battery may start the vehicle under normal conditions but may not be able to operate in more extreme conditions. Extreme heat or cold could expose a weak battery and cause it to fail.

Table 3: Battery Decisions

Decision	Recommended Action
GOOD BATTERY	Return the battery to service.
GOOD-RECHARGE	Fully charge the battery and return it to service.
CHARGE REQUIRED	Fully charge the battery using a Midtronics Diagnostic Charger and retest. Failure to fully charge the battery before retesting may cause false readings. If CHARGE REQUIRED appears again after you fully charge the battery, replace the battery.
REPLACE BATTERY	A REPLACE BATTERY result may also mean a poor connection between the battery and the vehicle. If you tested the battery using the IN-VEHICLE Test, disconnect the battery cables and retest using the OUT-OF-VEHICLE Test before replacing it.
BAD CELL-REPLACE	Replace the battery. WARNING: Do not charge the battery. Charging a battery with one or more bad cells could cause an explosion and serious harm to the user.
OK-REPLACE SOON	The battery may fail under extreme climate conditions. A REPLACE battery result may also mean a poor connection between the battery and the battery terminal connectors. If you tested the battery using the IN-VEHICLE Test, disconnect the battery cables and retest using the OUT-OF-VEHICLE Test before replacing it.
24 VOLT BATTERY	24-volt battery detected. You are attempting to test in-vehicle both batteries in a 24-volt system. Disconnect the batteries and test them individually.



NOTES: When testing at remote posts, the analyzer may need to verify a possible REPLACE result. It will give you the option of retesting at the battery posts.

When testing at side posts, the analyzer may find that the data is inconclusive and instruct you to test with side post adapters.

Chapter 7: System Test

The system test first evaluates the battery, then the starting and charging systems.

IMPORTANT: When you start a new test, the last test results in memory are overwritten. Remember to record or print the results if you need to retain them.

Battery Test

The System Test includes a test of the battery to eliminate it as the cause of starting or charging problems. See Chapter 6 on page 22 for the Battery Test procedure.

Starter System Test

The performance of the starter and charging systems depends on the battery's condition. It is important that the battery is good and fully charged before any further system testing.

1. In the Main Menu select the Battery test icon.

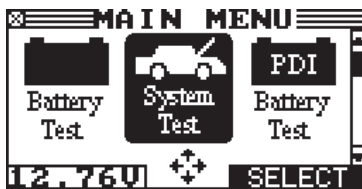

2. Start the engine at the prompt. If after the vehicle started and the results do not appear after approximately 25 seconds, press the **NO START** soft key.

3. The analyzer displays one of six decisions and the results in a series of screens.



NOTE: In some cases, the analyzer may not detect the vehicle's starting profile and display the soft key options **STARTED** and **NO START**. If you select **STARTED**, the analyzer skips to the Charging System Test. If you select **NO START**, the test process ends.

Starter System Test Results

The results include the battery analysis. Use the **UP** or **DOWN ARROW** key to scroll to each screen. See Table 4 for on the next page for an explanation of the starter system decisions. To continue testing, press the **NEXT** soft key.

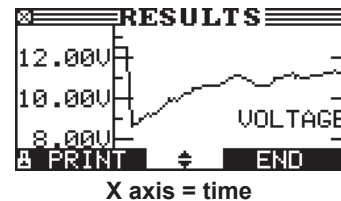
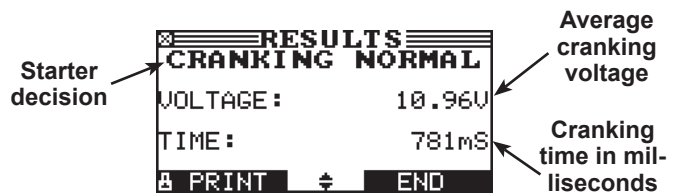

Table 4: Starter System Decisions

Starting System Decision	Action
CRANKING NORMAL	The starter voltage is normal and the battery is fully charged.
LOW VOLTAGE	The starter voltage is low and the battery is fully charged.
CHARGE BATTERY	The starter voltage is low and the battery is discharged. Fully charge the battery using a Midtronics Diagnostic Charger and retest the starter system.
REPLACE BATTERY	Replace the battery and retest before testing the alternator test..
NO START	The engine did not start and the test was aborted.

Charging System Test

When you press **NEXT** in any test result screen, the analyzer proceeds to the Charging System Test.

1. CHECKING FOR ALTERNATOR OUTPUT: The analyzer is testing for alternator voltage.
2. TURN ALL VEHICLE LOADS OFF, IDLE ENGINE: Turn off vehicle loads (blowers, interior light, radio, etc.) and idle the engine. Press the **NEXT** soft key to continue.



NOTE: If necessary the analyzer will ask if you are testing a diesel engine. It will resume testing after you make your selection.

3. REV ENGINE WITH LOADS OFF FOR 5 SECONDS: Rev the engine with the loads off. Gradually increase the rpm until the analyzer tells you to HOLD the rev level as the bar on the display moves to the right.



NOTE: Some 8-cylinder and older vehicles idle at a high level after starting, allowing the analyzer to detect the rev automatically.

4. ACQUIRING DATA....HOLD ENGINE RPM: Continue to hold the rpm while the analyzer takes system measurements.
5. ENGINE REV DETECTED, IDLE ENGINE: The analyzer has detected the rev. Press the **NEXT** soft key.
6. TESTING ALTERNATOR AT IDLE, LOADS OFF: The analyzer will next test the engine at idle for comparison to other readings, and then test the diode ripple. Excessive ripple usually means one or more diodes have failed in the alternator or there is stator damage.
7. TURN HIGH BEAMS AND BLOWER MOTOR ON, IDLE ENGINE: After a few seconds, the analyzer will ask you to turn on the accessory loads. It will determine if the charging system is able to provide enough current for the demands of the electrical system.

IMPORTANT: Turn on the high-beam headlights and the blower to high. Do not use cyclical loads such as air conditioning or windshield wipers.

8. TESTING ALTERNATOR AT IDLE, LOADS ON: The analyzer will determine if the charging system is able to provide sufficient current for the demands of the vehicle's electrical system.
9. REV ENGINE WITH LOADS ON FOR 5 SECONDS: The analyzer will test the charging system with the loads on and prompt you to rev the engine. Gradually increase the rev until the analyzer tells you to HOLD the rev level as the bar on the display moves to the right.

10. ACQUIRING DATA....HOLD ENGINE RPM: Continue to hold the rpm while the analyzer takes system measurements.
11. ENGINE REV DETECTED, IDLE ENGINE: The analyzer has detected the rev. Press the **NEXT** soft key.
12. ANALYZING CHARGING SYSTEM DATA: The analyzer is completing its final analysis of the charging system data.
13. TURN OFF LOADS AND ENGINE: Press the **NEXT** soft key to display the results. See Table 5 on the next page for an explanation for the test decisions.



NOTE: When the option TRACK CALLS is enabled, the EXP writes the results to the data card.

Charging System Test Results

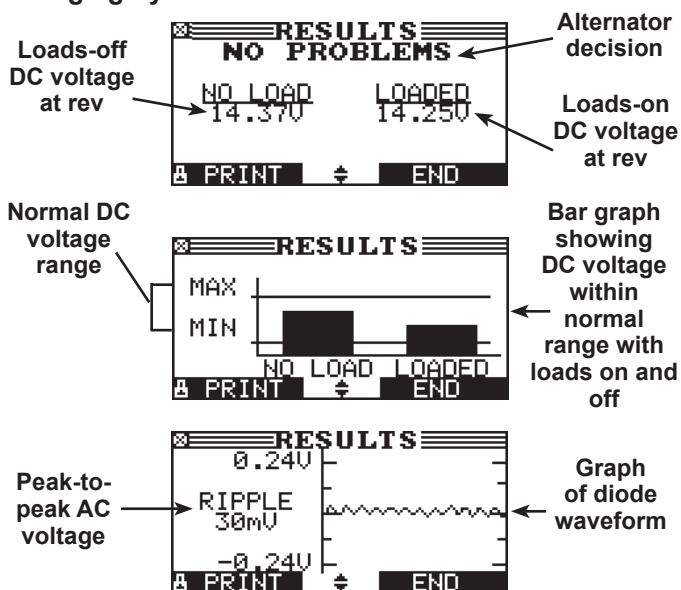

Table 5: Charging System Decisions

Charging System Decision	Action
NO PROBLEMS	The system is showing normal output from the alternator. No problem detected.
NO OUTPUT	<p>The alternator is not providing charging current to the battery.</p> <ul style="list-style-type: none"> √ Check the belts to ensure the alternator is rotating with the engine running. Replace broken or slipping belts and retest. √ Check all connections to and from the alternator, especially the connection to the battery. If the connection is loose or heavily corroded, clean or replace the cable and retest. √ If the belts and connections are in good working condition, replace the alternator. (Older vehicles use external voltage regulators, which may require only replacement of the voltage regulator.)
LOW OUTPUT	<p>The alternator is not providing enough current to power the system's electrical loads and charge the battery.</p> <ul style="list-style-type: none"> √ Check the belts to ensure the alternator is rotating with the engine running. Replace broken or slipping belts and retest. √ Check the connections from the alternator to the battery. If the connection is loose or heavily corroded, clean or replace the cable and retest.
HIGH OUTPUT	<p>The voltage output from the alternator to the battery exceeds the normal limits of a functioning regulator.</p> <ul style="list-style-type: none"> √ Check to ensure there are no loose connections and that the ground connection is normal. If there are no connection problems, replace the regulator. (Most alternators have a built-in regulator requiring you to replace the alternator. In older vehicles that use external voltage regulators, you may need to replace only the voltage regulator.) <p>The regulator controls voltage output based on the battery voltage, under-hood temperature, and vehicle loads used. In other words, it controls the maximum voltage the system can produce based on the current needs and amount of current that can be produced by the spinning of the rotor in the alternator. The normal high limit of a typical automotive regulator is 14.5 volts ± 0.5. Refer to the manufacturer specifications for the correct limit, which may vary by vehicle type.</p> <p>A high charging rate will overcharge the battery and may decrease its life and cause it to fail. If the battery test decision is REPLACE and the charging system test shows a HIGH OUTPUT, check the battery's electrolyte levels. A symptom of overcharging is battery fluid spewing through the vent caps, which causes low electrolyte levels and will harm the battery.</p>

Table 6: Diode Decisions

Diode Decision	Action
EXCESSIVE RIPPLE	<p>One or more diodes in the alternator are not functioning or there is stator damage, which is shown by an excessive amount of AC ripple current supplied to the battery.</p> <ul style="list-style-type: none"> √ Make sure the alternator mounting is sturdy and that the belts are in good shape and functioning properly. If the mounting and belts are good, replace the alternator.
OPEN PHASE	The analyzer has detected an open phase within the alternator. Replace the alternator.
OPEN DIODE	The analyzer has detected a open diode within the alternator. Replace the alternator.
SHORTED DIODE	The analyzer has detected an shorted diode within the alternator. Replace the alternator.

Chapter 8: PDI Battery Test

The PDI Battery Test in the Main Menu enables you to quickly check new batteries in your inventory. The test can verify up to 100 batteries in succession using the CCA rating and units or JIS part number that you provide. This test differs from the Battery Test in that the decision is either pass or fail. Neither decision will tell you that a battery is bad, but rather that the measured voltage and CCA fall in or out of your requirements.

IMPORTANT: The New Battery Test does not produce a test code.

Selecting Test Parameters

1. Select the New Battery Test icon in the Main Menu.

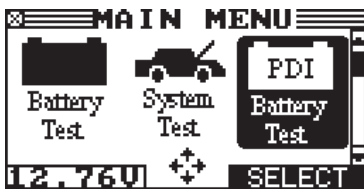

2. The EXP displays the total number of PDI Tests completed out of 100. To clear the results from memory and reset the total to 0, simultaneously press the **LEFT** and **RIGHT ARROW** keys. Press the **NEXT** soft key to continue.

IMPORTANT: Be sure to monitor the number of tests performed and be ready to print the results as the number approaches 100. When the limit is reached you will no longer be able to test until you clear all results from memory.

3. Enter the information required in steps 6 through 9 in "Chapter 6: Battery Test" on pages 22 and 23.
4. For the next few seconds the EXP evaluates the battery, writes the results to the data card, and displays the results starting from the last battery tested. To view a previous result for a battery, use the **UP** or **DOWN ARROW** key to scroll to the screen showing the battery that was tested.

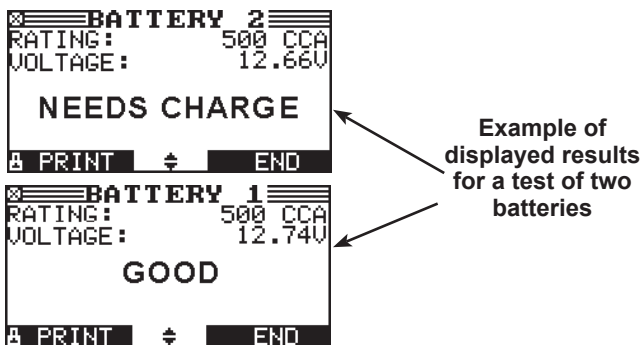

5. To continue testing, connect to the next battery. The analyzer starts the test automatically using the same parameters. To test another type of battery press **END**, then follow steps 1 through 3 above.

Printing Test Results

1. To print the test results for an individual battery, use the **UP** or **DOWN ARROW** key to scroll to the screen showing the battery that was tested. Select the **PRINT** soft key.
2. Select option 1 to print the screen result of the selected battery. Select option 2 to print the results of all the batteries listed by the order in which they were tested. Press **NEXT**.
 - 1 PDI BATTERY
 - 2 PDI SUMMARY

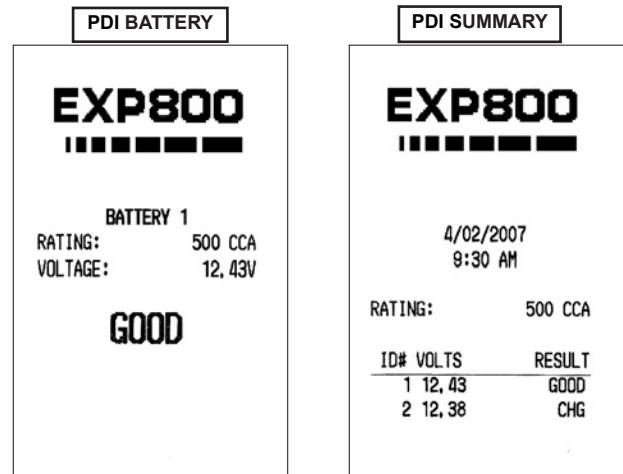

When the EXP displays a total of 100 Tests

The analyzer will not be able to continue inventory testing until you clear all tests from its memory.



NOTE: To retain a record, use the **PRINT** soft key to print the results.

To clear the results and reset the counter to 0:

1. Select the **EXIT** soft key to return to the Main Menu.
2. Select the New Battery Test icon.
3. In the INVENTORY STAT screen press the **LEFT** and **RIGHT ARROW** key simultaneously to clear the results and reset the counter to 0.

Chapter 9: Info Menu

The Info Menu has several types of reports to help you manage your test data and track the usage and history of your analyzer. All the reports can be displayed and sent to an optional handheld or to the analyzer's internal printer. It also has a utility to transfer test data to a PC using an optional IR receiver and software package. In the Main Menu, select the Info icon.



View Test



This report displays the results of the Battery and System Tests. See "Battery Test Results" on page 23, "Starter System Test Results" on page 25 and "Charging System Test Results" on page 26.

View PDI Test



This report displays and prints the results for an individual battery or for all batteries tested using the PDI Battery Test on page 28.

- To print the test results for an individual battery, use the **UP** or **DOWN ARROW** key to scroll to the screen showing the order in which the battery was tested. Select the **PRINT** soft key.
- Select option 1 to print the screen result of the selected battery. Select option 2 to print the results of all the batteries listed by the date and order in which they were tested. Select the **PRINT** soft key.

- PDI BATTERY
- PDI SUMMARY

Totals



The TOTALS menu shows the total number of tests in four categories since the totals were reset to zero. Use the UP or DOWN ARROW key to move the dot to the option button of your choice (1, 2, 3, or 4). See the screen illustrations on the next page.

- TOTALS

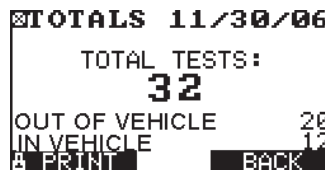

TOTALS displays the total number of battery tests performed **OUT OF VEHICLE** and **IN VEHICLE** since the EXP was first used. The **IN-VEHICLE** total includes tests performed by selecting the **SYSTEM** icon.

- USER TOTALS



USER TOTALS displays the total number of tests performed by user including the unregistered users.

- SYSTEM TEST

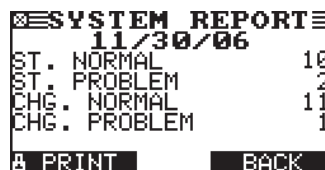

SYSTEM TEST displays the total number of Starting and Charging Test decisions.

- TOTALS BY DECISION

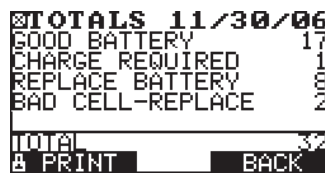

TOTALS BY DECISION displays the total number of tests by battery decision.

Transfer



The TRANSFER utility lets you transfer test data to a PC using an optional IR receiver and software package. The list of test codes is also sent to the data card if the card is inserted into the EXP.

Version



Version displays the analyzer's software version, the software release date, the analyzer serial number. The utility keeps a permanent count of the number of battery tests performed since the analyzer was first used.

Chapter 10: Printing Test Results

If you are using the EXP internal printer, keep the clamps connected to the battery during the printing process. After a test the results automatically print.



NOTE: When the option TRACK CALLS is enabled, the EXP writes the results to the data card.

To print a second copy of the results:

1. Press the **PRINT** soft key.
2. Select the language for the printed results. Use the **UP/DOWN ARROWS** to move the dot to the option button of your choice (1, 2, or 3).
 - 1 ENGLISH
 - 2 ESPAÑOL
 - 3 FRANÇAIS
3. Press the **NEXT** soft key to continue.

Changing the Paper in the Internal Printer

The internal printer is shipped with a roll of thermal printing paper installed in the paper compartment. The roll size is 2-1/4 inches wide by 1-7/8 inch in diameter. Replacement rolls are available at most office supply stores.

To replace the paper roll:

1. Unlock the printer door by gently pressing down on the red lever.
2. Lift the printer door and remove the spent roll.

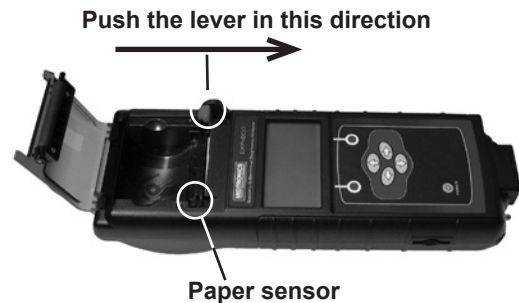

3. Place a new roll of paper in the compartment. As the diagram in the paper compartment indicates, the paper feeds from the bottom of the roll.
4. Pull the paper forward so that it extends past the serrated edge of the paper slot.



5. Close the door and make sure the lever locks securely. For a clean tear, pull the paper along the serrated edge. **Do not pull the paper straight out of the printer.**



Chapter 11: Troubleshooting

In addition to the troubleshooting suggestions in this chapter, the EXP Help Menu provides tips on troubleshooting problems with the printer, the cables, and loss of power. It also includes Midtronics Customer Service phone numbers.

Problems with the Display

The display does not turn on:

- Check the connection to the battery.
- The analyzer's internal batteries may need to be replaced. See "Chapter 13: EXP Internal Batteries" on page 34.

The display flickers or is dim:

- The contrast may need to be adjusted in the Admin/Utility menu. Highlight the Display icon and press ENTER. Use the UP or DOWN ARROW key to scroll the contrast value to 10.
- The analyzer's internal batteries may need to be replaced. See "Chapter 13: EXP Internal Batteries" on page 34.

Problems with the Internal Printer

The internal printer will not print

- The analyzer must be connected to the vehicle battery to print to the internal printer. Check the clamp connections to the battery.
- The vehicle battery may be too low to power the printer. Connect to a battery with at least 11.5 volts.
- Verify that the paper is properly installed.
- Verify that the paper sensor is clean and undamaged (see page 30).

Chapter 12: Test Cable Maintenance

The test cables that come with your analyzer are consumable items. Cables are like tires in that the more you use them and the harder you drive them, the shorter their useful life. Here are a few things you can do to protect your test cables from damage and premature wear:

Cleaning the Clamps

- The grease, dirt, and sulfation that build up on battery terminals are highly corrosive and can damage the clamps over time. Before connecting the clamps, ensure accurate test readings and protect the clamps by cleaning the battery case and terminals using a wire brush and a mixture of water and baking soda.
- Periodically clean the clamps using a mixture of baking soda and water, or a mild hand-soap, and a small bristle brush.
- To protect the clamps from oil and dirt, clip them to the back of the analyzer as shown.



Handling the Test Cables

- Always connect and disconnect the clamps to the battery by opening and closing the clamps. Never pull on the test cables to remove the battery clamps. Pulling can damage the Y-junction, the cables, and the clamps to the extent that the analyzer may produce lower-than-expected conductance readings or fail completely.
- Never carry the analyzer by the cables. Carrying the analyzer or swinging it by the cables puts unnecessary strain on the cables and can result in premature failure. Handle the analyzer with care to get the maximum use from the product.

Storing Test Cables

- Never wrap the cables around the analyzer; this puts unnecessary strain on the test cables.

Because the test cables are the “tires” of the analyzer, they have a certain life expectancy and will wear out eventually. However, the abuse examples cited above are not covered under warranty. To ensure the best performance and longest life of the test cables, attach and remove them with care, and carry the analyzer and cables together.

Testing Resistance in the Cable Set

If the analyzer frequently displays CHECK CLAMP CONNECTION! you may have an intermittent open circuit along one or both of the battery test cables. You can check the circuit with a simple test. The test requires an ohmmeter and a wire or paper clip if the ohmmeter probes are too large to insert into the pin holes. You will also need to a pencil or plastic marker to keep the clamp jaws apart.

Test Procedure

You are testing the continuity of the following end points:

- The positive (RED clamp jaw without teeth and its corresponding pin hole).
 - The positive (RED) clamp jaw with teeth and its corresponding pin hole.
 - The negative (black) clamp jaw without teeth and its corresponding pin hole.
 - The negative (black) clamp jaw with teeth and its corresponding pin hole.
1. Grip a pencil with the clamp as shown in the figure *Contacts for Clamp Jaws*. Do not grip the metal part of the eraser or any area that may conduct current.
 2. Insert a probe tip into the hole designated "NO TEETH" for the color (BLACK or RED) of the clamp you are testing as shown in the figure "Contacts for Cable Connector."
 3. Touch the toothless jaw of the clamp with the other probe tip. Wiggle the battery test cables. The resistance reading should be less than 1 Ω .
 4. Repeat the test for the "TEETH" side of the circuit, this time touching the jaw with teeth. Insert the other probe tip into the "teeth" pin hole. Wiggle the battery test cables. The resistance reading should be less than 11 Ω .

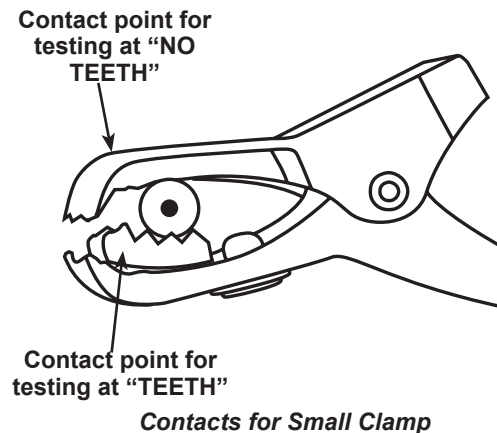
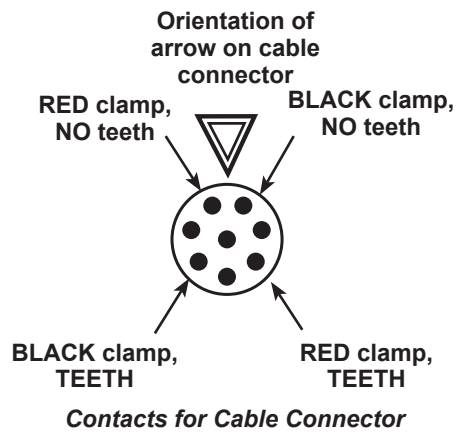

Chapter 13: EXP Internal Batteries

The EXP uses six AA, 1.5-volt batteries (alkaline recommended) to allow testing of batteries down to 1 volt and supply power while the menu is active.

Battery Power Indicator

The square in the upper left corner of the display indicates the charge level of the battery pack. The square is black when the battery pack is fully charged. It gradually changes to white as the charge level declines. The EXP will display a warning message when the batteries need replacing.

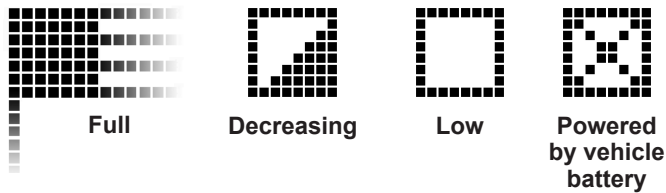

Replacing the Internal Batteries

1. Turn the analyzer face down.
2. Use a Philips screwdriver to remove the screw securing the door to the battery compartment.



3. Lift the door at the tab and place it aside.
4. Remove the discharged batteries.
5. Insert new batteries as shown. Make sure the positive and negative terminals are positioned correctly.
6. Reposition the door on the battery compartment.
7. Reinsert and tighten the screw.

