



INSTALLATION INSTRUCTIONS FOR PART 99-5700

APPLICATIONS

FORD/JEEP/LINCOLN/MERCURY

99-5700/AT-509FD

AW-509FD/DW-5510

99-5700

KIT FEATURES

- DIN Mount Radio Provision
- Shaft Mount Radio Provision in Select Vehicles
- ISO Mount Radio Provision in Select Vehicles

KIT COMPONENTS

A) Radio Housing #1 • B) Radio Housing #2 • C) Brackets Set #1 (Econoline)
D) Bracket #2 (Escort/Lynx) • E) Shaft Supports • F) Spacer Set #1 • G) ISO DIN
Brackets • H) (4) #8 X 3/4" Phillips Pan-Head Screws • I) (2) #6 Self Tapping
Screws

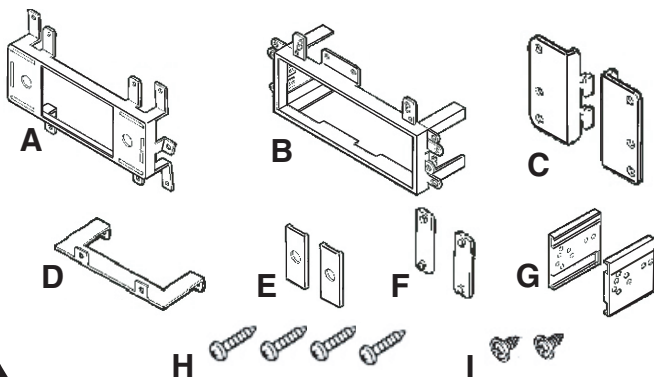

TOOLS REQUIRED:

- Cutting Tool • Phillips Screwdriver
- 86-5618 Head Unit Removal Keys



FORD Aerostar 1992-97

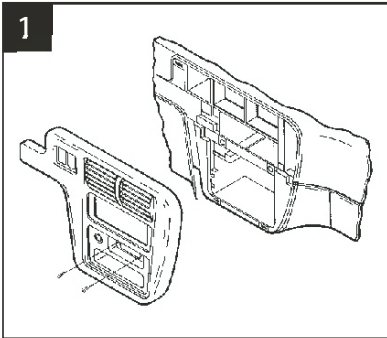

Disconnect the negative battery terminal to prevent an accidental short circuit. Remove (2) screws from the steering column trim panel and (2) screws from the ashtray cavity. Unclip the dash trim bezel. Using Metra's 86-5618, pull the factory head unit from the dash and disconnect the wiring. Skip to step #3c in the installation Instructions for ALL VEHICLES on Page #22.

FORD Aerostar 1985-91

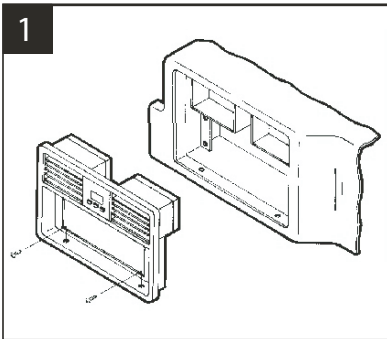

Disconnect the negative battery terminal to prevent an accidental short circuit. Remove (2) Phillips screws from the base of the dash trim bezel. Pry down on the (2) tabs located at the top of the dash trim bezel and remove the bezel. Remove (4) screws securing the factory head unit and disconnect the wiring.

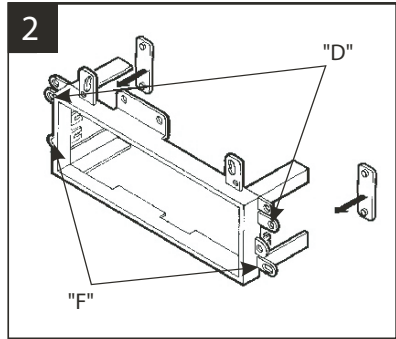

Cut and remove all mounting tabs on Radio Housing #2 EXCEPT tabs "D" and "F". The mounting tabs can be identified by the stamped letter on the back of each tab. Locate Spacer Set #1. (The Spacers must be placed behind the mounting tabs during installation in step #5). Skip to the Installation Instructions for ALL VEHICLES on Page #21.

FORD Aspire 1994-97

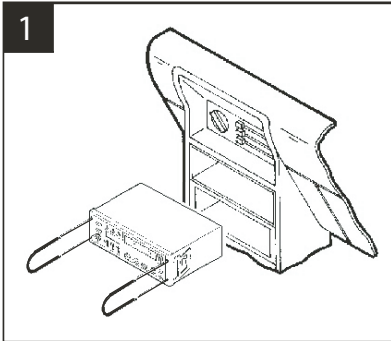

Disconnect the negative battery terminal to prevent an accidental short circuit. Using Metra's 86-5618, pull the factory head unit from the dash and disconnect the wiring. Skip to step #3c in the installation Instructions for ALL VEHICLES on Page #22.

FORD Bronco / Pickup 1980-86

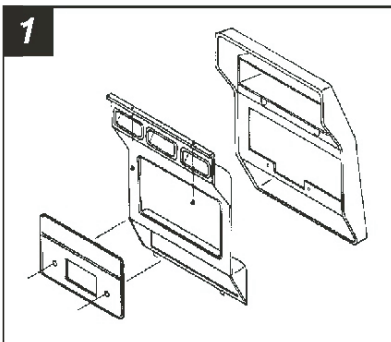

Disconnect the negative battery terminal to prevent an accidental short circuit. Remove (2) screws from the top edge of the dash trim bezel. Pull out on the top of the bezel, unhook the base and remove the bezel. If a factory head unit is NOT present, scribe the (4) mounting holes and radio opening onto the bezel. Drill the holes, cut the opening and place (4) U-clips over the mounting positions.

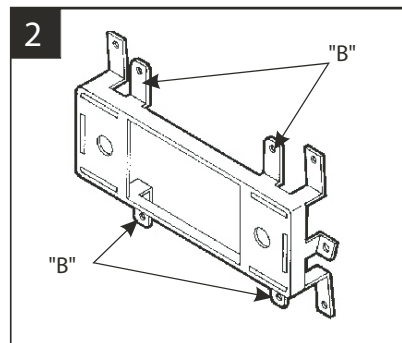

Cut and remove all mounting tabs on Radio Housing #1 EXCEPT tabs "B". The mounting tabs can be identified by the stamped letter on the back of each tab. Skip to the Installation Instructions for ALL VEHICLES on Page #21.

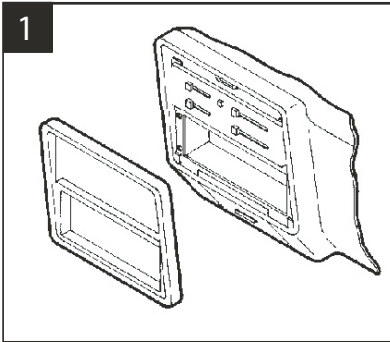
FORD Bronco (full size) / F-Series Pickup 1987-91

1
Disconnect the negative battery terminal to prevent an accidental short circuit. Carefully pull and remove the dash trim bezel. Remove (4) screws securing the factory head unit and disconnect the wiring.

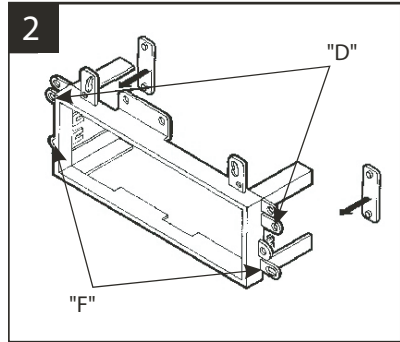

2
Cut and remove all mounting tabs on Radio Housing #2 EXCEPT tabs "D" and "F". The mounting tabs can be identified by the stamped letter on the back of each tab. Locate Spacer Set #1. (The Spacers must be placed behind the mounting tabs during installation in step #5). Skip to the Installation Instructions for ALL VEHICLES on Page #21.

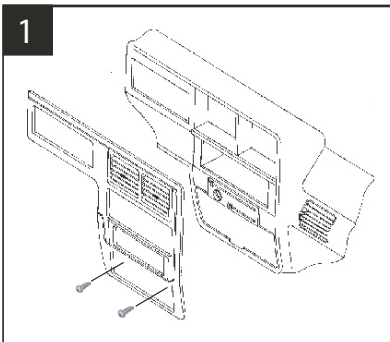
**FORD Bronco II 1989-90 / Explorer 1991-94 / Ranger 1989-94
MAZDA Navajo 1991-94 / B-Series Pickup 1994**

1
Disconnect the negative battery terminal to prevent an accidental short circuit. Remove the ashtray and (2) screws exposed in the ashtray cavity. Using Metra's 86-5618, pull the factory head unit from the dash and disconnect the wiring.

Skip to step #3c in the installation Instructions for ALL VEHICLES on Page #22.

FORD Bronco II / Ranger 1985-88

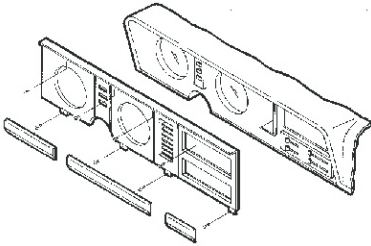
1

Disconnect the negative battery terminal to prevent an accidental short circuit. Remove (4) Phillips screws from the top edge of the dash trim bezel. Remove the light switch knob, cigarette lighter and ashtray. Unsnap the molding located below the dash trim bezel and remove (4) screws exposed. Remove (4) screws securing the factory head unit and disconnect the wiring.

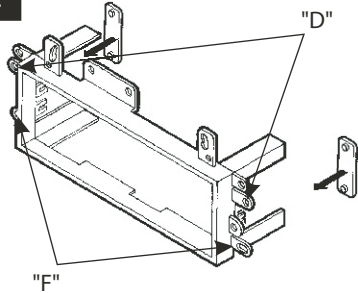
2

Cut and remove all mounting tabs on Radio Housing #2 EXCEPT tabs "D" and "F". The mounting tabs can be identified by the stamped letter on the back of each tab. Locate Spacer Set #1. (The Spacers must be placed behind the mounting tabs during installation in step #5). Skip to the Installation Instructions for ALL VEHICLES on Page#21.

FORD Contour 1995-00 / MERCURY Mystique 1995-99

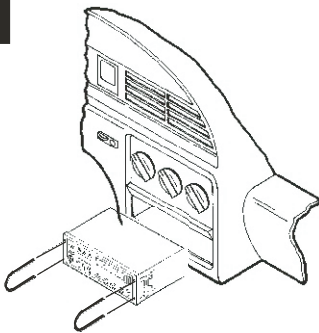
1

Disconnect the negative battery terminal to prevent an accidental short circuit. Using Metra's 86-5618, pull the factory head unit from the dash and disconnect the wiring. Skip to step #3c in the installation Instructions for ALL VEHICLES on Page #22.

**FORD Crown Victoria 1991-94
MERCURY Grand Marquis 1991-94**

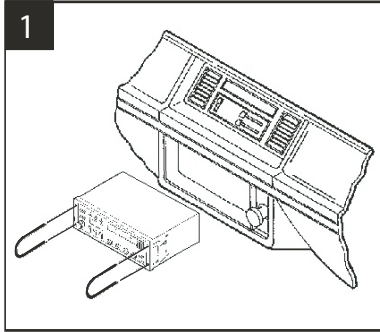

Disconnect the negative battery terminal to prevent an accidental short circuit. Using Metra's 86-5618, pull the factory head unit from the dash and disconnect the wiring. Skip to step #3c in the installation Instructions for ALL VEHICLES on Page #22.

**FORD Crown Victoria / LTD 1979-90
MERCURY Grand Marquis / Marquis 1979-90**

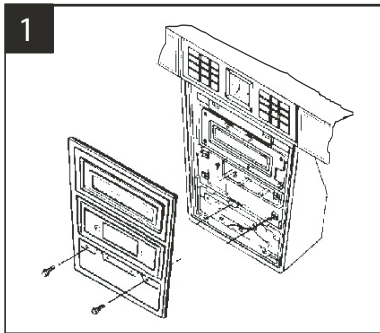

Disconnect the negative battery terminal to prevent an accidental short circuit. Open the ashtray and remove (2) Phillips screws securing the dash trim bezel. Remove (4) screws securing the factory head unit and disconnect the wiring.

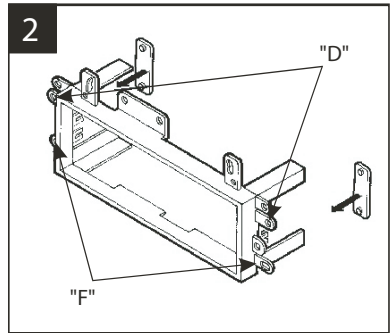

Cut and remove all mounting tabs on Radio Housing #2 EXCEPT tabs "D" and "F". The mounting tabs can be identified by the stamped letter on the back of each tab. Locate Spacer Set #1. (The Spacers must be placed behind the mounting tabs during installation in step #5). Skip to the Installation Instructions for ALL VEHICLES on Page #21.

FORD Econoline 1992-96

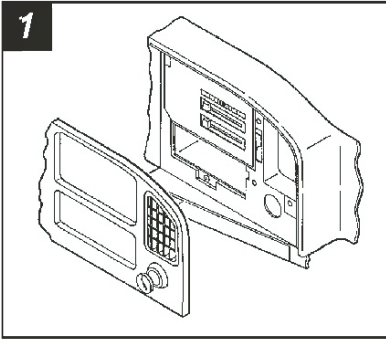

Disconnect the negative battery terminal to prevent an accidental short circuit. Remove the light switch knob and unscrew the surrounding trim. Remove the cupholder and the screws exposed in the cupholder cavity. Unsnap the (2) trim bezel inserts and remove the screws exposed. Remove the lower steering column trim panel and unclip the dash trim bezel. Using Metra's 86-5618, pull the factory head unit from the dash and disconnect the wiring. Skip to step #3c in the installation Instructions for ALL VEHICLES on Page #22.

FORD Econoline 1975-91

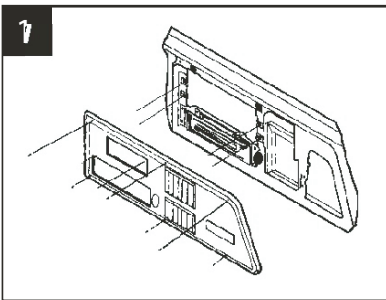

Disconnect the negative battery terminal to prevent an accidental short circuit. Remove (3) screws from the lower edge of the dash trim bezel. Remove (2) screws above the radio opening. Unsnap the right corner of the dash trim bezel, disconnect the cigarette lighter wiring and remove the bezel. Remove the screws securing the factory head unit and disconnect the wiring.

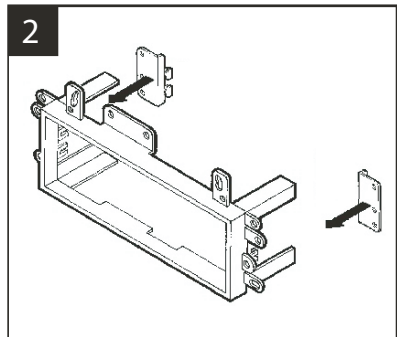

Cut and remove all mounting tabs on Radio Housing #2. The mounting tabs can be identified by the stamped letter on the back of each tab. Slide Bracket Set #1 into the slots on the sides of the Housing. Skip to the Installation Instructions for ALL VEHICLES on Page #21.

FORD Escort / MERCURY Tracer 1991-96

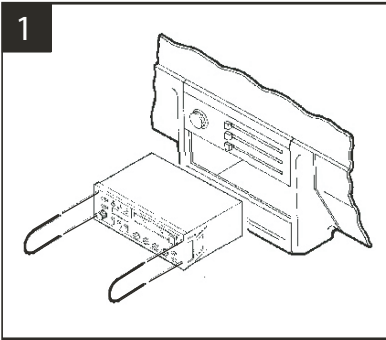

1
Disconnect the negative battery terminal to prevent an accidental short circuit. Using Metra's 86-5618, pull the factory head unit from the dash and disconnect the wiring. Skip to step #3c in the installation Instructions for ALL VEHICLES on Page #22.

FORD Escort / MERCURY Lynx 1985-90

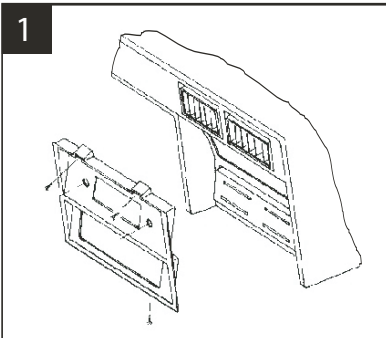

1
Disconnect the negative battery terminal to prevent an accidental short circuit. Remove (4) screws from the top edge of the dash trim bezel. Remove (2) screws from the bottom edge of the dash trim bezel. Remove the climate control knobs and remove the bezel. Remove (4) hex-head screws securing the factory head unit and disconnect the wiring.

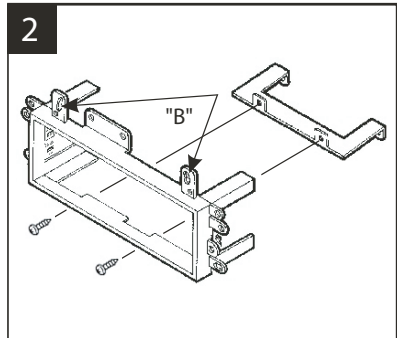

2
Cut and remove all mounting tabs on Radio Housing #2 EXCEPT tabs "B". The mounting tabs can be identified by the stamped letter on the back of each tab. Mount Bracket #2 to the bottom of the Housing with (2) #8 x 3/4" Phillips Screws supplied. Skip to the Installation Instructions for ALL VEHICLES on Page #21.

FORD F-Series Pickup / Bronco 1992-96

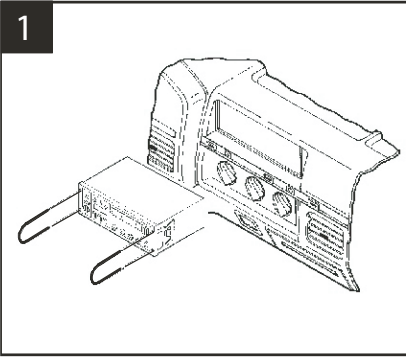
1

Disconnect the negative battery terminal to prevent an accidental short circuit. Using Metra's 86-5618, pull the factory head unit from the dash and disconnect the wiring. Skip to step #3c in the installation Instructions for ALL VEHICLES on Page #22.

FORD Festiva 1988-93

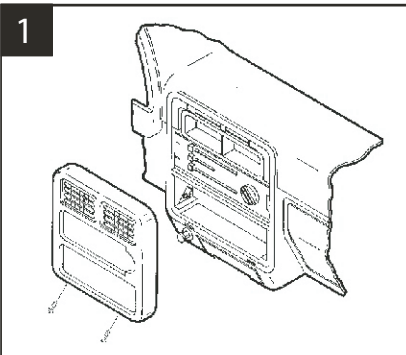
1

Disconnect the negative battery terminal to prevent an accidental short circuit. Remove (4) Phillips screws from the bottom of the dash trim bezel. Remove the bezel. Remove (2) screws securing the factory head unit and disconnect the wiring.

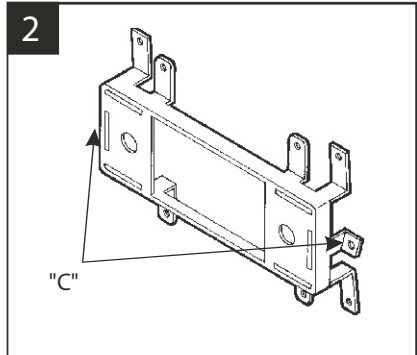
2

Cut and remove all mounting tabs on Radio Housing #1 EXCEPT tabs "C". The mounting tabs can be identified by the stamped letter on the back of each tab. Skip to the Installation Instructions for ALL VEHICLES on Page #21.

FORD Mustang 1994-00

1

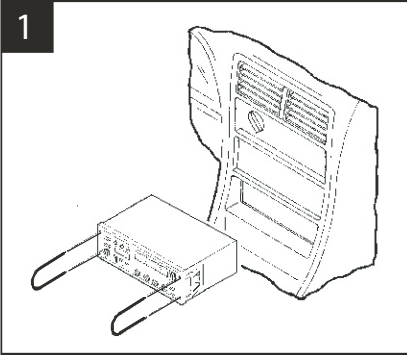

Disconnect the negative battery terminal to prevent an accidental short circuit. Using Metra's 86-5618, pull the factory head unit from the dash and disconnect the wiring. Skip to step #3c in the installation Instructions for ALL VEHICLES on Page #22.

FORD Probe 1993-97

1

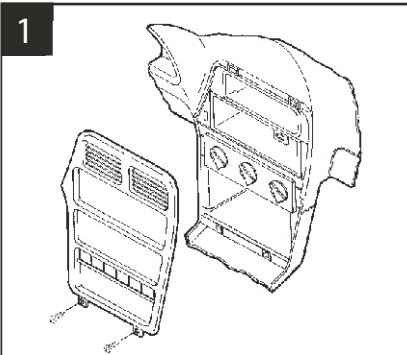

Disconnect the negative battery terminal to prevent an accidental short circuit. Remove (2) screws from the base of the dash trim bezel. Unclip and remove the bezel. Using Metra's 86-5618, pull the factory head unit from the dash and disconnect the wiring. Skip to step #3c in the installation Instructions for ALL VEHICLES on Page #22.

FORD Taurus / MERCURY Sable 1990-95

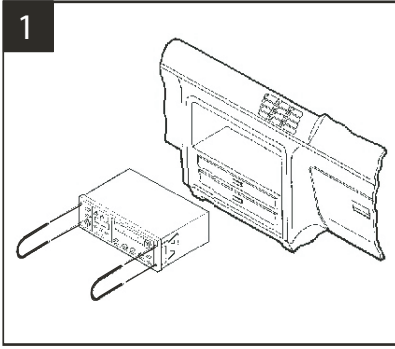

1
Disconnect the negative battery terminal to prevent an accidental short circuit. Using Metra's 86-5618, pull the factory head unit from the dash and disconnect the wiring. Skip to step #3c in the installation Instructions for ALL VEHICLES on Page #22.

FORD Taurus / MERCURY Sable 1986-89

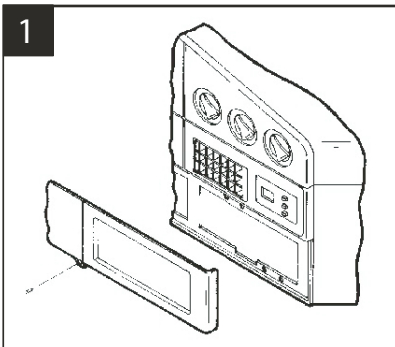

1
Disconnect the negative battery terminal to prevent an accidental short circuit. Remove (1) 7mm hex-head screw from the bottom of the radio trim bezel. Gently unclip the bezel and disconnect the antenna switch power lead. Remove (4) screws securing the factory head unit and disconnect the wiring.

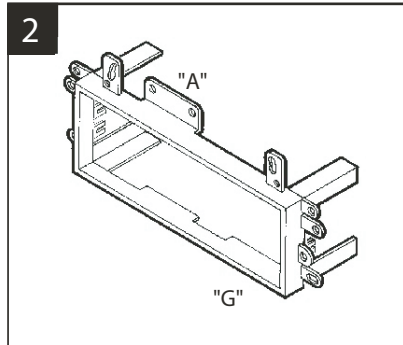

2
Cut and remove all mounting tabs on Radio Housing #2 EXCEPT tabs "A" and "G". The mounting tabs can be identified by the stamped letter on the back of each tab. Skip to the Installation Instructions for ALL VEHICLES on Page #21.

FORD Tempo / MERCURY Topaz 1989-94

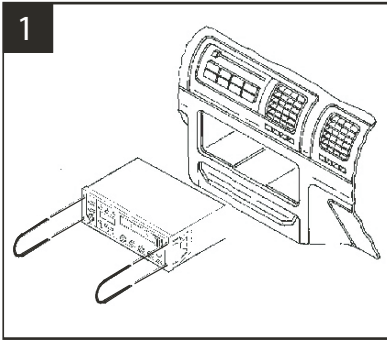

1
Disconnect the negative battery terminal to prevent an accidental short circuit. Using Metra's 86-5618, pull the factory head unit from the dash and disconnect the wiring.

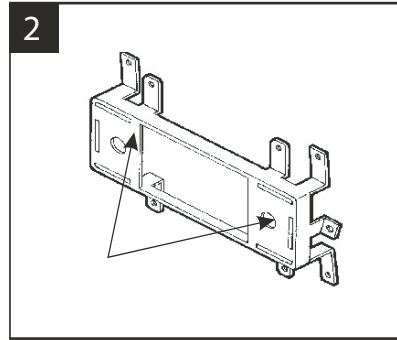

2
Cut and remove the shaft supports from the Faceplate. Skip to step #3c in the Installation Instructions for ALL VEHICLES on Page#22.

FORD Tempo / MERCURY Topaz 1985-88

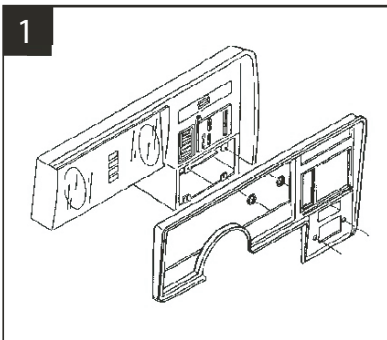

1
Disconnect the negative battery terminal to prevent an accidental short circuit. Remove the ashtray by disengaging the release tab at the rear of the ashtray bracket. Remove (2) screws from the lower edge of the dash trim bezel. Unclip the top edge of the bezel and remove. Remove (4) screws securing the factory head unit and disconnect the wiring.

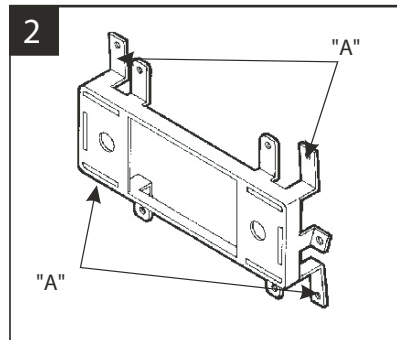

2
Cut and remove all mounting tabs on Radio Housing #1 EXCEPT tabs "A". The mounting tabs can be identified by the stamped letter on the back of each tab. Skip to the Installation Instructions for ALL VEHICLES on Page#21.

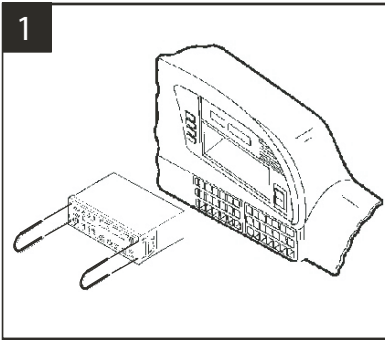
FORD Thunderbird / MERCURY Cougar 1989-97

1
Disconnect the negative battery terminal to prevent an accidental short circuit. Using Metra's 86-5618, pull the factory head unit from the dash and disconnect the wiring. Skip to step #3c in the installation Instructions for ALL VEHICLES on Page #22.

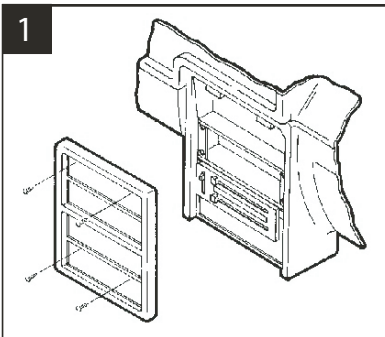
FORD Thunderbird / MERCURY Cougar 1985-88

1
Disconnect the negative battery terminal to prevent an accidental short circuit. Remove (2) screws from the top of the dash trim bezel. Open the ashtray and remove (2) screws from the ashtray cavity. Remove (4) screws securing the factory head unit and disconnect the wiring.

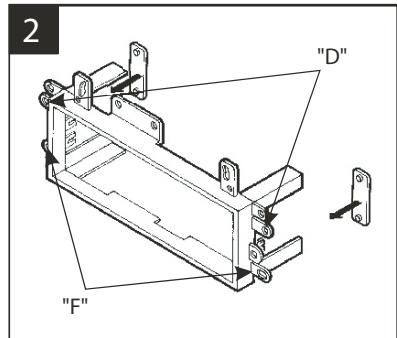

2
Cut and remove all mounting tabs on Radio Housing #2 EXCEPT tabs "D" and "F". The mounting tabs can be identified by the stamped letter on the back of each tab. Locate Spacer Set #1. (The Spacers must be placed behind the mounting tabs during installation in step #5). Skip to the Installation Instructions for ALL VEHICLES on Page #21.

FORD Windstar 1995-98

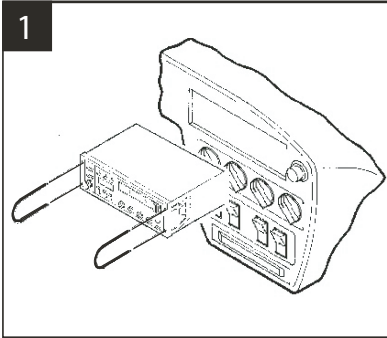

1
Disconnect the negative battery terminal to prevent an accidental short circuit. Using Metra's 86-5618, pull the factory head unit from the dash and disconnect the wiring. Skip to step #3c in the installation Instructions for ALL VEHICLES on Page #22.

JEEP Cherokee 1984-95 / Comanche 1986-92 Wagoneer 1984-96

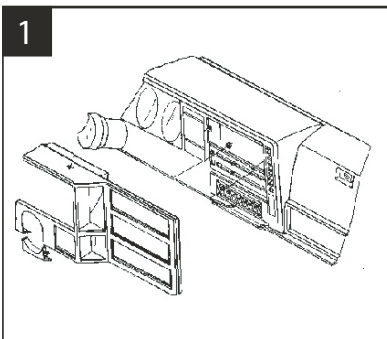

1
Disconnect the negative battery terminal to prevent an accidental short circuit. Unsnap the steering column trim panel and remove. Remove (4) screws from the dash trim bezel and remove the bezel. Remove (2) screws securing the factory head unit and disconnect the wiring.

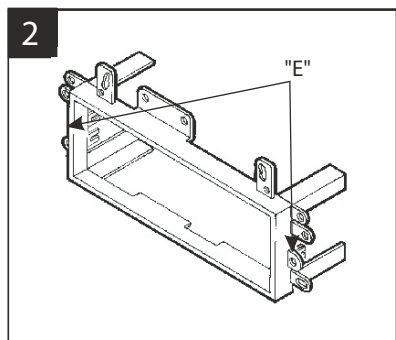

2
Cut and remove all mounting tabs on Radio Housing #2 EXCEPT tabs "E". The mounting tabs can be identified by the stamped letter on the back of each tab. Skip to the Installation Instructions for ALL VEHICLES on Page #21.

JEEP Cherokee 1996

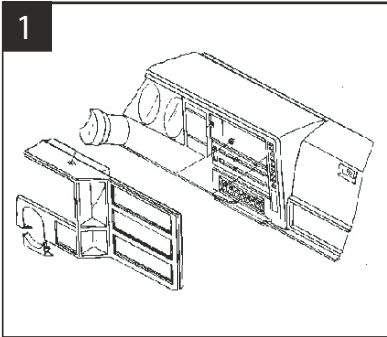

Disconnect the negative battery terminal to prevent an accidental short circuit. Remove (3) torx-head screws from the steering column trim panels. Unscrew the tilt steering lever and unsnap the trim panels. Remove (4) screws from the dash trim bezel and remove the bezel. Remove (2) screws securing the factory head unit and disconnect the wiring.

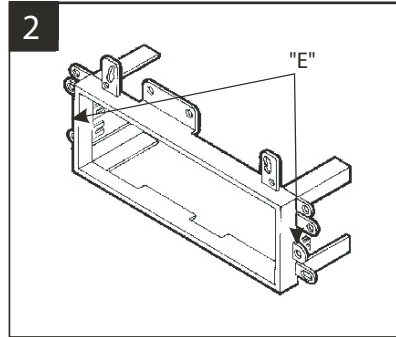

Cut and remove all mounting tabs on Radio Housing #2 EXCEPT tabs "E". The mounting tabs can be identified by the stamped letter on the back of each tab. Skip to the Installation Instructions for ALL VEHICLES on Page #21.

JEEP Grand Wagoneer 1987-95

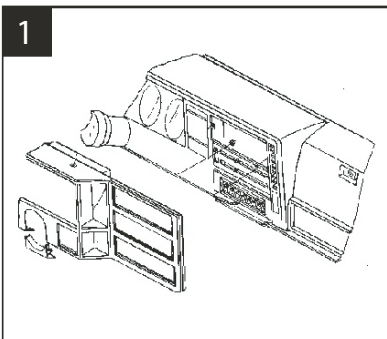

Disconnect the negative battery terminal to prevent an accidental short circuit. Gently unclip the dash trim bezel. Remove (2) screws securing the factory head unit and disconnect the wiring.

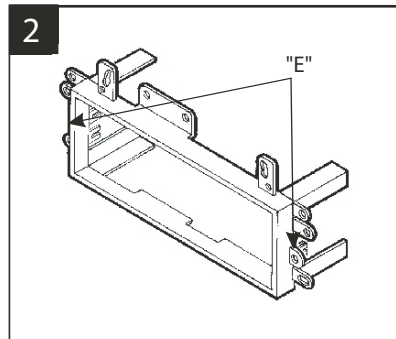

Cut and remove all mounting tabs on Radio Housing #2 EXCEPT tabs "E". The mounting tabs can be identified by the stamped letter on the back of each tab. Skip to the Installation Instructions for ALL VEHICLES on Page #21.

JEEP Wrangler 1986-96

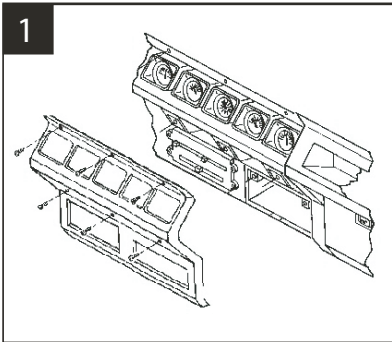

1
Disconnect the negative battery terminal to prevent an accidental short circuit. Remove (6) Phillips screws from the face of the dash trim bezel. Remove the bezel. Remove (2) screws securing the factory head unit and disconnect the wiring.

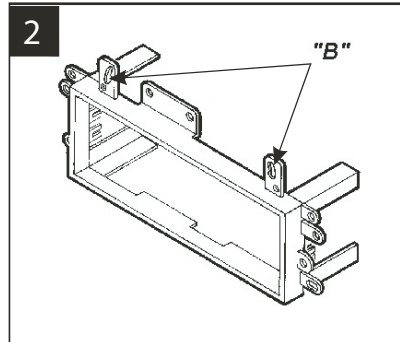

2
Cut and remove all mounting tabs on Radio Housing #2 EXCEPT tabs "B". The mounting tabs can be identified by the stamped letter on the back of each tab. Skip to the Installation Instructions for ALL VEHICLES on Page #21.

LINCOLN Continental 1988-94 / Mark VII 1990-92 Town Car 1990-94

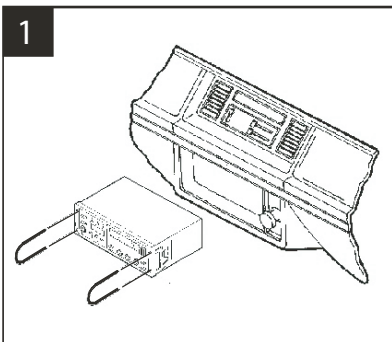

1
Disconnect the negative battery terminal to prevent an accidental short circuit. Using Metra's 86-5618, pull the factory head unit from the dash and disconnect the wiring. Skip to step #3c in the installation Instructions for ALL VEHICLES on Page #22.

LINCOLN Continental 1985-87

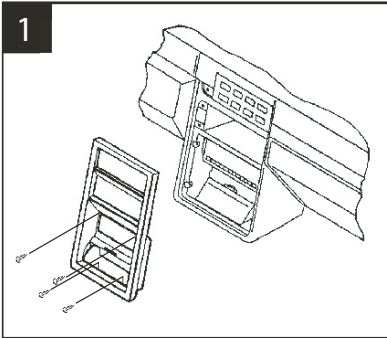

Disconnect the negative battery terminal to prevent an accidental short circuit. Remove (2) #8 Phillips screws below the radio opening. Open the ashtray and remove (2) #8 Phillips screws exposed (it is NOT necessary to remove the center screw). Unclip and remove the dash trim bezel. Remove (4) hex-head screws securing the factory head unit and disconnect the wiring.

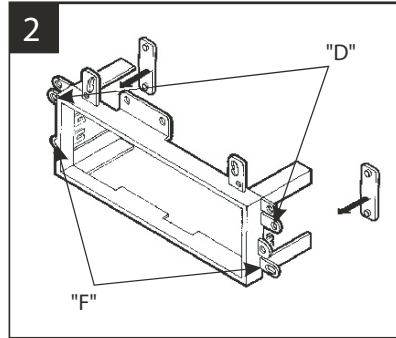

Cut and remove all mounting tabs on Radio Housing #2 EXCEPT tabs "D" and "F". The mounting tabs can be identified by the stamped letter on the back of each tab. Locate Spacer Set #1. (The Spacers must be placed behind the mounting tabs during installation in step #5). Skip to the Installation Instructions for ALL VEHICLES on Page #21.

LINCOLN Mark VII 1984-89

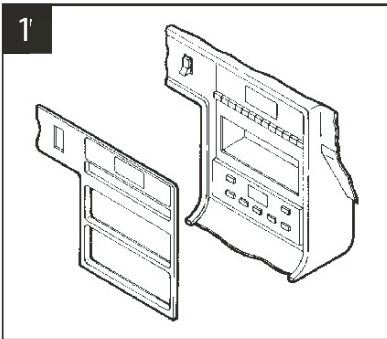

Disconnect the negative battery terminal to prevent an accidental short circuit. Gently pry out on the dash trim bezel and remove. Remove (4) 5mm hex-head sheet metal screws securing the factory head unit and disconnect the wiring.

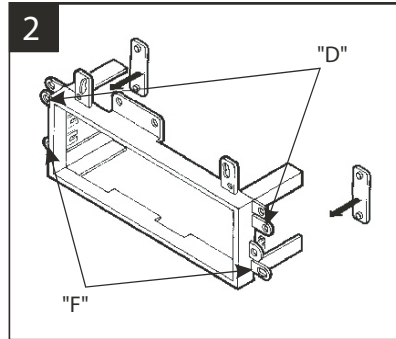

Cut and remove all mounting tabs on Radio Housing #2 EXCEPT tabs "D" and "F". The mounting tabs can be identified by the stamped letter on the back of each tab. Locate Spacer Set #1. (The Spacers must be placed behind the mounting tabs during installation in step #5). Skip to the Installation Instructions for ALL VEHICLES on Page #21.

LINCOLN Mark VIII 1993-95

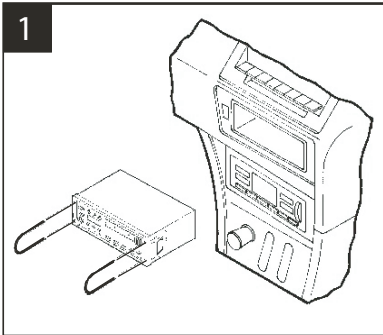

1
Disconnect the negative battery terminal to prevent an accidental short circuit. Using Metra's 86-5618, pull the factory head unit from the dash and disconnect the wiring. Skip to step #3c in the installation Instructions for ALL VEHICLES on Page #22.

LINCOLN Town Car 1984-89

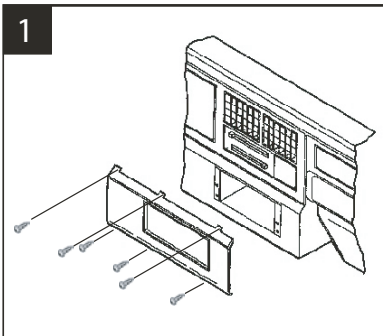

1
Disconnect the negative battery terminal to prevent an accidental short circuit. Remove (3) #8 Phillips screws from the bottom of the radio trim bezel. Unsnap the plastic strip located above the bezel and remove (3) Phillips screws exposed. Gently pull the instrument cluster trim bezel away from the dash and remove the radio trim bezel. Remove (3) hex-head screws securing the factory head unit and disconnect the wiring.

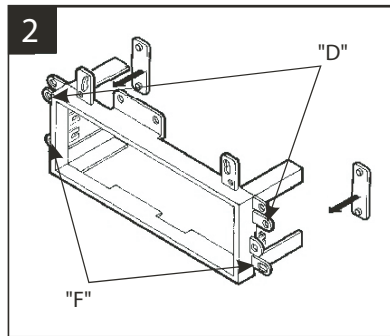

2
Cut and remove all mounting tabs on Radio Housing #2 EXCEPT tabs "D" and "F". The mounting tabs can be identified by the stamped letter on the back of each tab. Locate Spacer Set #1. (The Spacers must be placed behind the mounting tabs during installation in step #5). Skip to the Installation Instructions for ALL VEHICLES on Page #21.

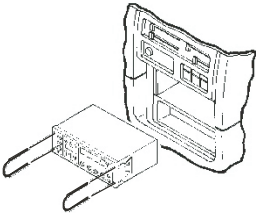
MAZDA MPV 1996-99**1**

Skip to step #3c in the installation Instructions for ALL VEHICLES on Page #22.

Disconnect the negative battery terminal to prevent an accidental short circuit. Unsnap the side trim pieces from the factory head unit. Using Metra's 86-5618, pull the unit from the dash and disconnect the wiring.

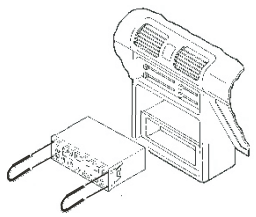
MAZDA MX3 1992-96**1**

Skip to step #3c in the installation Instructions for ALL VEHICLES on Page #22.

Disconnect the negative battery terminal to prevent an accidental short circuit. Using Metra's 86-5618, pull the factory head unit from the dash and disconnect the wiring.

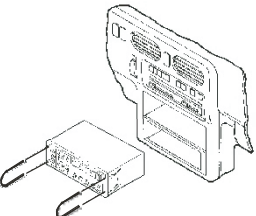
MAZDA MX6 1993-97 / 626 1993-00**1**

Skip to step #3c in the installation Instructions for ALL VEHICLES on Page #22.

Disconnect the negative battery terminal to prevent an accidental short circuit. Using Metra's 86-5618, pull the factory head unit from the dash and disconnect the wiring.

MAZDA Protege 1995-00

1

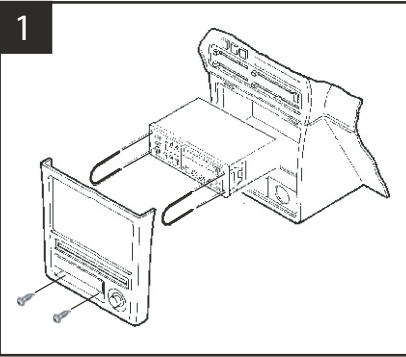

Disconnect the negative battery terminal to prevent an accidental short circuit. Remove the ashtray and (2) screws from the ashtray cavity. Using Metra's 86-5618, pull the factory head unit from the dash and disconnect the wiring.

Skip to step #3c in the installation Instructions for ALL VEHICLES on Page #22.

MERCURY Capri XR2 1991-94

1

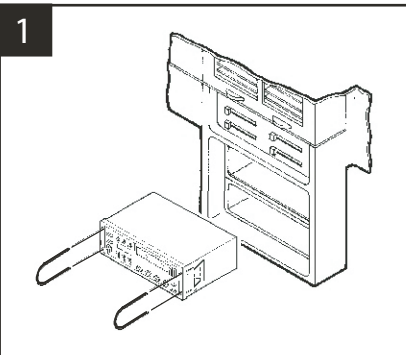

Disconnect the negative battery terminal to prevent an accidental short circuit. Using Metra's 86-5618, pull the factory head unit from the dash and disconnect the wiring.

Skip to step #3c in the installation Instructions for ALL VEHICLES on Page #22.

MERCURY Tracer (hatchback) 1989-90

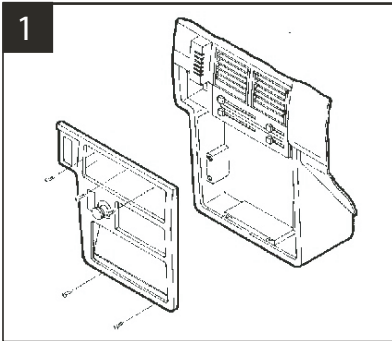

Disconnect the negative battery terminal to prevent an accidental short circuit. Remove (3) Phillips screws from the top of the dash trim bezel. Remove the ashtray and (2) Phillips screws from the bottom of the bezel. Remove (4) Phillips screws securing the factory head unit and disconnect the wiring. Skip to step #3c in the installation Instructions for ALL VEHICLES on Page #22.

MERCURY Villager 1993-96 / NISSAN Quest 1993-95

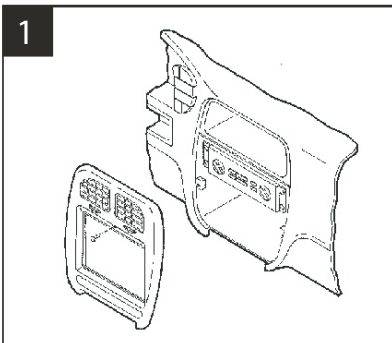

Disconnect the negative battery terminal to prevent an accidental short circuit. Remove (1) screw above the climate controls. Unclip the dash trim bezel. Using Metra's 86-5618, pull the factory head unit from the dash and disconnect the wiring. Skip to step #3c in the installation Instructions for ALL VEHICLES on Page #22.

ALL VEHICLES

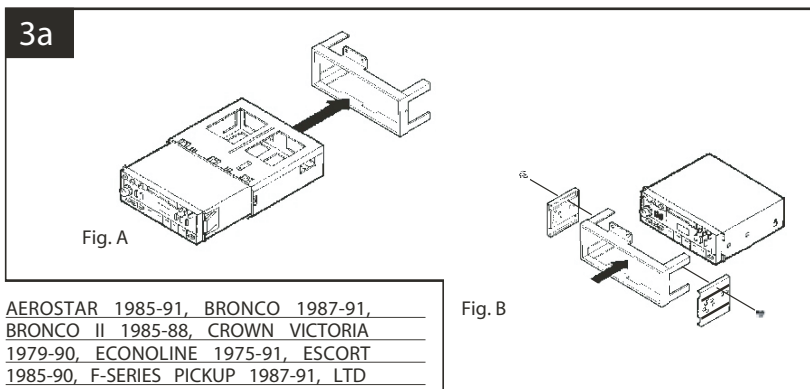
3a

AEROSTAR 1985-91, BRONCO 1987-91, BRONCO II 1985-88, CROWN VICTORIA 1979-90, ECONOLINE 1975-91, ESCORT 1985-90, F-SERIES PICKUP 1987-91, LTD 1979-84, RANGER 1985-88, TAURUS 1986-89, THUNDERBIRD 1985-88, CONTINENTAL 1985-87, MARK VII 1984-89, TOWN CAR 1984-89, COUGAR 1985-88, GRAND MARQUIS 1979-90, LYNX 1985-90, MARQUIS 1979-90, SABLE 1986-89, TRACER (hatchback) 1988-90, all JEEPS:

For DIN units, slide the DIN cage into Radio Housing #2 and secure by bending the metal locking tabs down. Slide the aftermarket head unit into the cage until secure. (see Fig. A).

For ISO-DIN units, and slide the head unit into the back of the kit. Attach the ISO-DIN Brackets to the Housing legs, align the Bracket holes with the unit holes and secure the Brackets with (2) #6 Self-tapping Screws. (see Fig. B)

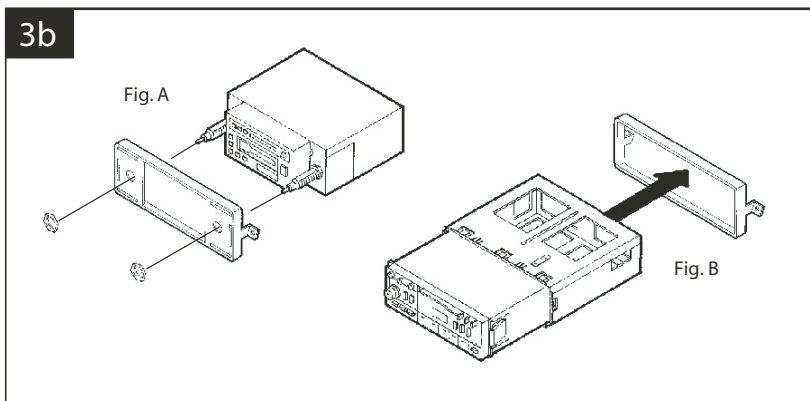
3b

BRONCO 1980-86, F-SERIES PICKUP 1980-86, FESTIVA 1988-93, TEMPO 1985-88, TOPAZ 1985-88: For 2-Shaft units, slide the aftermarket head unit into Radio Housing #1 and secure with shaft nuts. (see Fig. A). For Din units, cut and remove the shaft supports from Radio Housing #1. Slide the DIN cage into the Housing and secure by bending the metal locking tabs down. Slide the aftermarket head unit into the cage until secure. (see Fig. B)

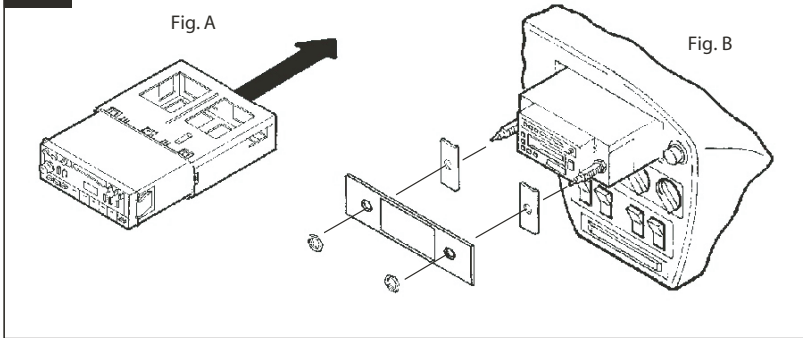
3c

AEROSTAR 1992-97, BRONCO II 1989-90, EXPLORER 1991-94, RANGER 1989-94, CROWN VICTORIA 1991-94, GRAND MARQUIS 1991-94, ECONOLINE 1992-96, ESCORT 1991-96, TRACER (sedan) 1991-96, F-SERIES PICKUP 1992-96, BRONCO 1992-96, TAURUS 1990-95, SABLE 1990-95, TEMPO 1989-94, TOP AZ 1989-94, THUNDERBIRD 1989-97, COUGAR 1989-97, CONTINENTAL 1988-94, MARK VII 1990-92, TOWN CAR 1990-94, MARK VIII 1993-95, ASPIRE, B-SERIES PICKUP, CONTOUR, MYSTIQUE, MUSTANG, PROBE, WINDSTAR, MPV, MX3, MX6, PROTEGE, 626, CAPRI XR2, VILLAGER, QUEST: For DIN units, Slide the DIN cage into the dash and secure by bending the metal locking tabs down. Slide the aftermarket head unit into the cage until secure. (see Fig. A). For 2-Shaft units, make wiring connections and slide the aftermarket unit into the dash. Slide the Shaft Supports over the radio shafts and position them along the inner lip of the radio opening. Place the faceplate against the outer lip of the radio opening and secure with shaft nuts. (see Fig. B)

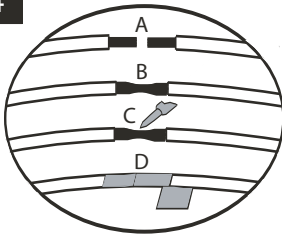
4

- A) Strip wire ends back 1/2"
- B) Twist ends together
- C) Solder
- D) Tape

Locate the factory wiring harness in the dash. Metra recommends using the proper mating adaptor and making connections as shown. (Isolate and individually tape off the ends of any unused wires to prevent electrical short circuit).

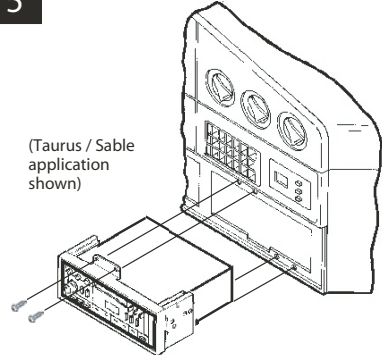
5

Re-connect the battery terminal and test the unit for proper operation. Mount the head unit/kit assembly to the sub-dash with those screws previously removed.