



INSTALLATION INSTRUCTIONS FOR PART 99-9999

APPLICATIONS **UNIVERSAL ISO STACK** **/DOUBLE DIN HEAD UNIT** **INSTALLATION KIT**

99-9999

KIT FEATURES

- ISO Stack and Double DIN Head Unit Provisions

KIT COMPONENTS

- A) Faceplate • B) ISO Brackets

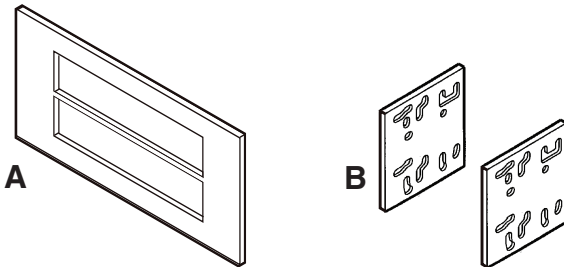

TOOLS REQUIRED:

- Phillips Screwdriver • Cutting Tool

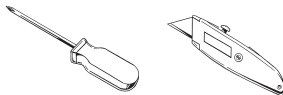

ALL VEHICLES

DOUBLE DIN HEAD UNITS: Disconnect the negative battery terminal to prevent an accidental short circuit. *Continue to Final Assembly.*

ISO STACK HEAD UNITS: Disconnect the negative battery terminal to prevent an accidental short circuit. Mount the ISO Brackets to the ISO-Stack head units using the hardware supplied with the unit (see Fig. A).

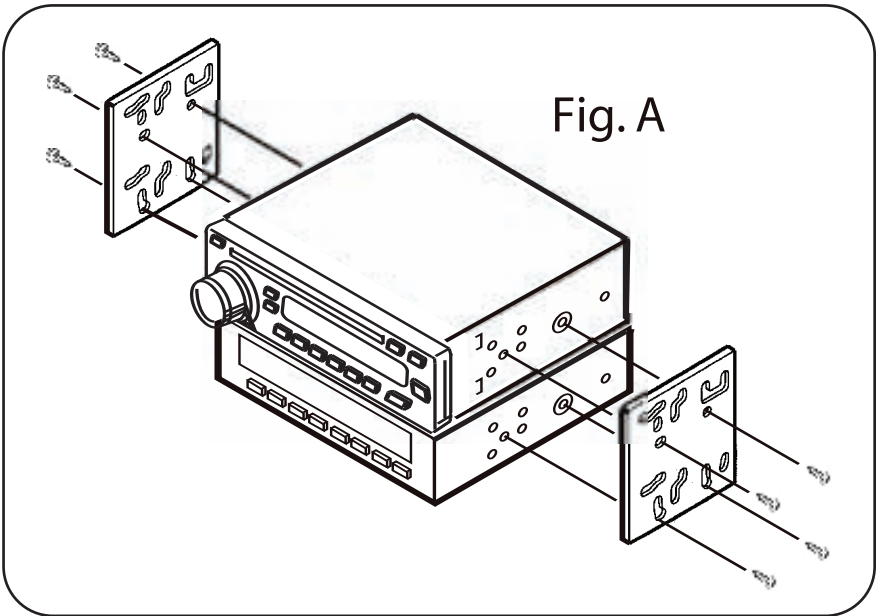

FINAL ASSEMBLY

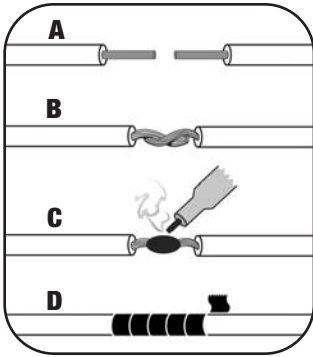

(A) Strip wire ends back 1/2"

(B) Twist ends together

(C) Solder

(D) Tape

- 1** Locate the factory wiring harness in the dash. Metra recommends using the proper mating adapter and making connections as shown. (Isolate and individually tape off the ends of any unused wires to prevent electrical short circuit.)
- 2** Re-connect the negative battery terminal and test the unit for proper operation.
- 3** Reassemble radio and dash assemblies in reverse order of disassembly.

FINAL WIRING CONNECTIONS

Make wiring connections using the EIA color code chart shown below and the instructions included with the head unit. Metra recommends making connections as shown below; Strip, Splice, Solder, Tape. Isolate and individually tape off ends of any unused wires to prevent electrical short circuit.

METRA / EIA WIRING CODE

12V Ignition / Acc. Red	Right Front (+) Gray
12V Batt / Memory Yellow	Right Front (-) Gray/ Black
Ground Black*	Left Front (+) White
Power Antenna Blue	Left Front (-) White / Black
Amp Turn-On Blue / White	Right Rear (+) Violet
Amp Ground Black / White	Right Rear (-) Violet / Black
Illumination Orange	Left Rear (+) Green
Dimmer Orange / White	Left Rear (-) Green / Black

***NOTE:** When a Black wire is not present, ground radio to vehicle chassis.
All colors may not be present on all leads due to manufacturer's specifications.

ALL VEHICLES

Slide the head unit(s) into the sub-dash and secure. *Continue to Page 4.*

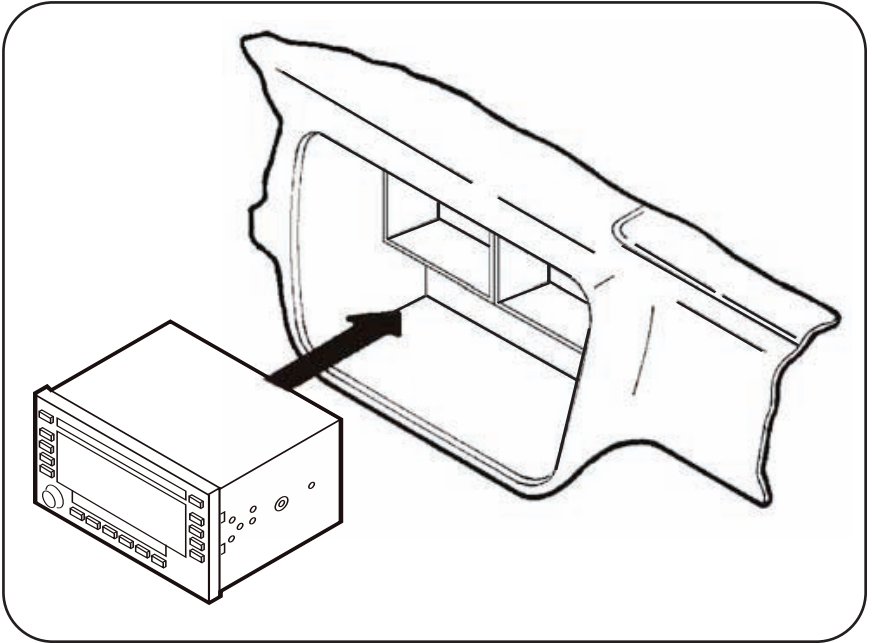

ALL VEHICLES

DOUBLE-DIN HEAD UNITS: Cut and remove the dividing rib in the center of the Faceplate ("A"). Place the Faceplate over the mounted head unit. Using the scored lines as a guide, cut the Faceplate to conform to the dash opening.

ISO-STACK HEAD UNITS: Place the Faceplate over the mounted head unit. Using the scored lines as a guide, cut the Faceplate to conform to the dash opening.

Continue to Page 5.

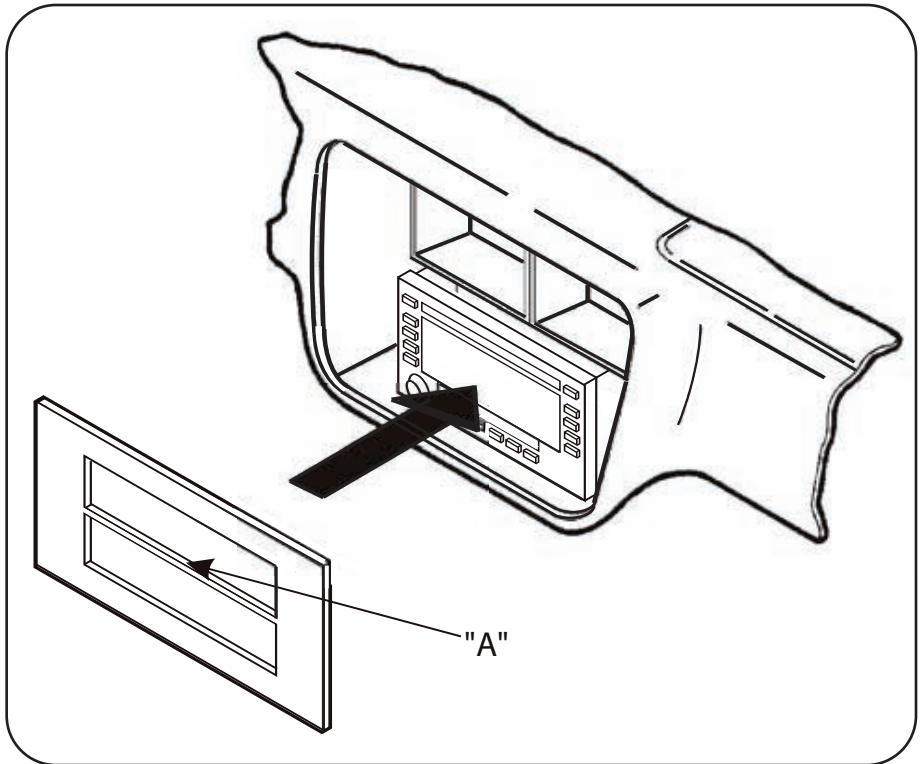

ALL VEHICLES

Turn the Faceplate to the smooth side and place over the mounted head unit. Re-attach the trim bezel (this will secure the Faceplate). Re-connect the battery terminal and test the unit for proper operation.

