



INSTALLATION INSTRUCTIONS FOR PART 99-5717

APPLICATIONS

Ford/Mercury 2004-2007 99-5717

KIT FEATURES

- ISO DIN head unit provisions
- Incorporates passenger air bag on/off light and factory climate controls



KIT COMPONENTS

- A) Integrated mounting kit
- B) ISO face plate
- C) Extension
- D) ISO brackets
- E) (2) #8 x 3/8" Phillips pan-head screws

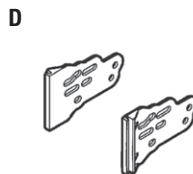
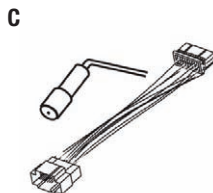
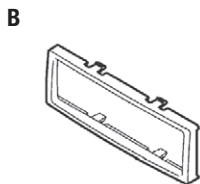
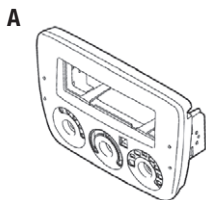

WIRING & ANTENNA CONNECTIONS (sold separately)

Wiring Harness:

- Included in kit

Antenna Adapter:

- 40-FD10 - Ford factory antenna to aftermarket radio

TOOLS REQUIRED

- Torx head screwdriver
- 86-5618 head unit removal keys

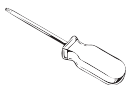



Dash Disassembly 99-5717

Ford Taurus/Mercury Sable 2004-2007

1. Using Metra's 86-5618, pull the factory radio/climate control panel from the dash. (Figure A)
2. Disconnect the audio system connectors, blower motor switch connector, vacuum hose harness, A/C damper door switch connector, and potentiometer connector.
3. Remove the panel.
4. Turn the factory climate control dials into a vertical position and pull the dials off. (Figure B, 1)
5. Remove (2) 5/16" hex head screws securing the temperature and fan control switches and remove the switches.
6. Unclip the climate control switch and remove the switch. (Figure B, 2)
7. Mount the switches to the back of the integrated mounting kit with (2) #8 x 3/8" Phillips pan-head screws supplied. (Figure C, 1)
8. Holding the climate control dials in a vertical position insert the dials onto the posts of the mounted switches and secure. (Figure C, 2)

Continued to kit preparation

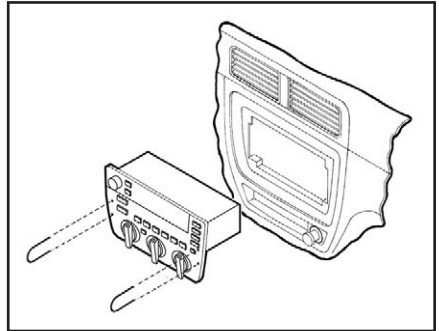

(Figure A)

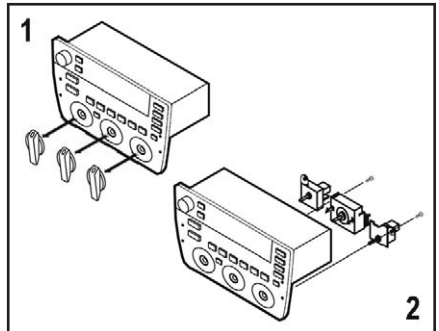

(Figure B)

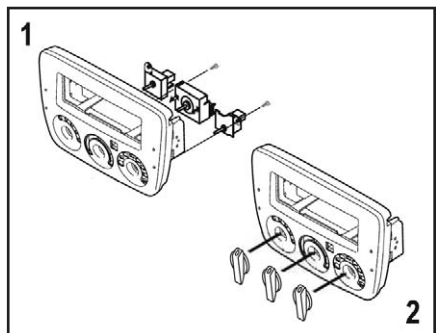

(Figure C)



Kit Assembly 99-5717

Kit preparation

1. Remove (2) Torx-head screws securing the mounting clips to the sides of the factory radio/climate control panel and remove the clips. (Figure A)
2. Mount the clips to the integrated mounting kit with the same Torx-head screws. (Figure B)

Continue to kit assembly

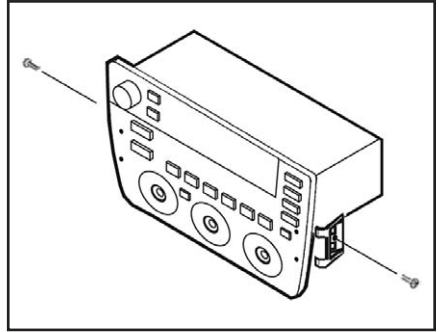

(Figure A)

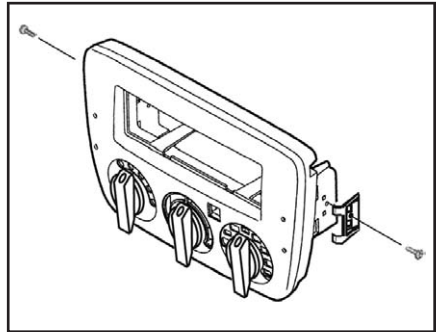

(Figure B)



Kit Assembly 99-5717

DIN head unit provision

1. Slide the DIN cage into the integrated mounting kit and secure by bending the metal locking tabs down.
2. Slide the aftermarket head unit into the cage and secure.
3. Locate the factory wiring harness in the dash. Metra recommends using the proper mating adapter from Metra or AXXESS. Re-connect the negative battery terminal and test the unit for proper operation.
4. Reassemble dash in reverse order of disassembly.

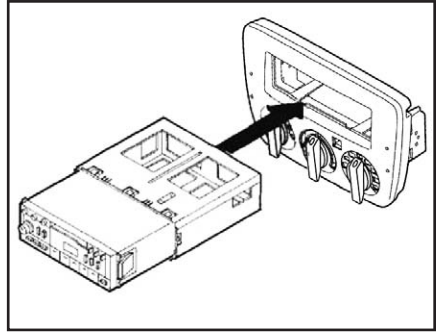

(Figure A)



Kit Assembly 99-5717

ISO head unit provision

1. Snap the ISO Faceplate into the radio opening.
2. Attach the ISO Brackets to the inner lip of the radio opening.
3. Slide the head unit into the radio opening; align the holes in the head unit with the holes in the ISO Brackets.
4. Mount the unit to the brackets with the screws supplied with the unit.
5. Locate the factory wiring harness in the dash. Metra recommends using the proper mating adapter from Metra or AXXESS. Re-connect the negative battery terminal and test the unit for proper operation.
6. Reassemble dash in reverse order of disassembly.

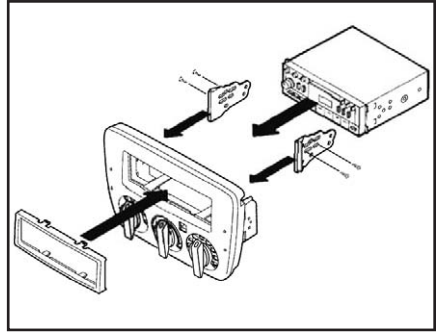

(Figure A)



Kit Assembly 99-5717

Additional kit assembly

1. Open the trunk, remove (4) pop-clips from the driver's side trunk liner and remove the liner. (Figure A)
2. Locate the factory tuner on the wall of the trunk and disconnect the speaker and antenna plugs (it is NOT necessary to remove the tuner). (Figure B)
3. Plug the 70-5715 into the unit speaker plug and the antenna extension lead into the unit antenna plug.
4. Slide the extension harness through the space in the back seat between the seat back and seat bottom.
5. Unclip the rocker trim, tuck the extension harness under the carpet and stretch the harness to the back of the dash (replace the rocker trim when completed).
6. Splice the speaker leads on the extension harness into the rear of the aftermarket head unit.
7. Plug the factory wiring harnesses into the switch connectors and audio connectors on the back of the integrated mounting kit.
8. Re-connect the battery terminal and test the unit, climate controls and rear defroster for proper operation.
9. Snap the integrated mounting kit assembly into the sub-dash. (Figure C)

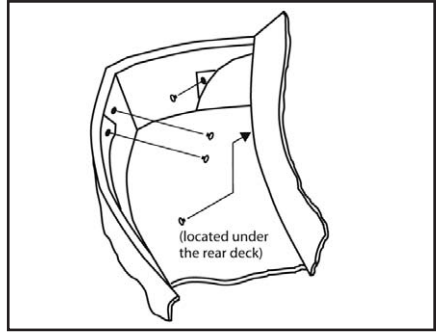

(Figure A)

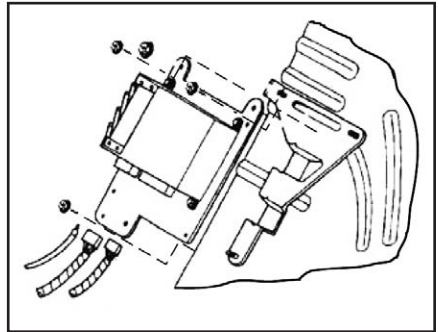

(Figure B)

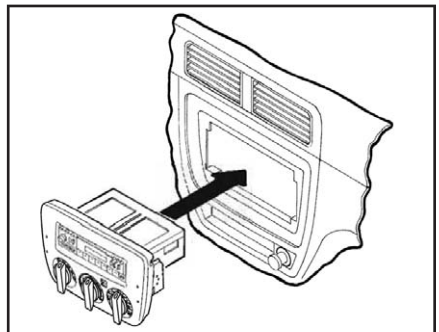

(Figure C)



INSTRUCCIONES DE INSTALACIÓN PARA LA PIEZA 99-5717

APLICACIONES

Ford/Mercury 2004-2007 99-5717

CARACTERÍSTICAS DEL KIT

- Provisiones de unidad central ISO DIN
- Incorpora la luz de encendido/apagado de la bolsa de aire del pasajero y los controles del clima de fábrica



COMPONENTES DEL KIT

- A) Kit de montaje integrado • B) Placa delantera ISO • C) Extensión • D) Soportes ISO
- E) (2) tornillos Phillips de cabeza troncocónica #8 x 3/8"

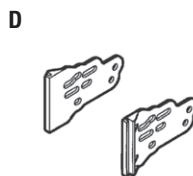
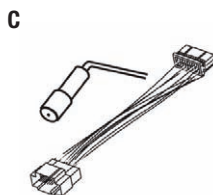
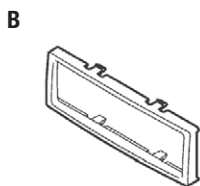
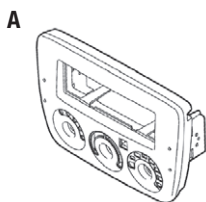

CABLEADO Y CONEXIONES DE ANTENA

Arnés de cableado: (se venden por separado)

- Incluido en el kit

Adaptador de antena:

- 40-FD10 - Ford antena de radio no original de fábrica

HERRAMIENTAS REQUERIDAS

- Llaves de remoción de unidad central 86-5618 • Destornillador de cabeza Torx





Desmontaje del tablero 99-5717

Ford Taurus/Mercury Sable 2004-2007

1. Usando las llaves 86-5618 de Metra, saque el panel del radio de fábrica/control del tablero. (Figura A)
2. Desconecte los conectores del sistema de audio, el conector del interruptor del motor del ventilador, el arnés de la manguera de vacío, el conector del interruptor de la puerta del atenuador de aire acondicionado y el conector del potenciómetro.
3. Retire el panel.
4. Ponga los selectores de control de clima de fábrica en posición vertical y jálelos para quitarlos. (Figura B, 1)
5. Retire los (2) tornillos de cabeza hexagonal de 5/16" que sujetan los interruptores de control de temperatura y del ventilador y retire los interruptores.
6. Desenganche el interruptor del control de clima y retire el interruptor. (Figura B, 2)
7. Monte los interruptores en la parte posterior del kit de montaje integrado con los (2) tornillos Phillips de cabeza troncocónica #8 x 3/8" suministrados. (Figura C, 1)
8. Sosteniendo los selectores del control de clima en posición vertical, insértelos en los postes de los interruptores montados y asegúrelos. (Figura C, 2)

Continuará la preparación del kit

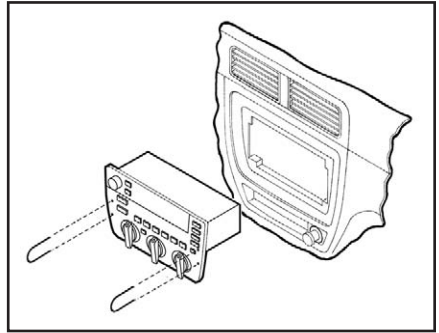

(Figura A)

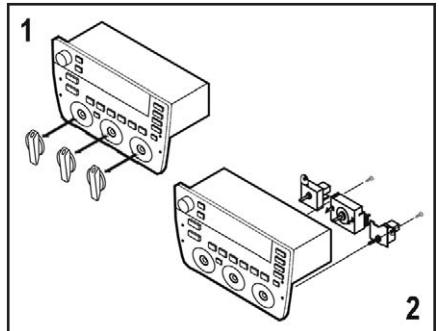

(Figura B)

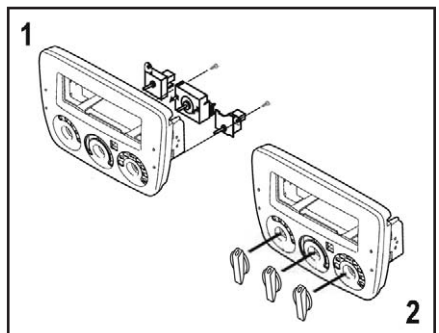

(Figura C)



Ensamble del kit 99-5717

Kit preparation

1. Retire los (2) tornillos de cabeza Torx que sujetan los ganchos de montaje a los lados del panel de radio de fábrica/control del clima y retire los ganchos. (Figura A)
2. Monte los ganchos en el kit integrado de montaje con los mismos tornillos de cabeza Torx. (Figura B)

Continuará al ensamble del kit

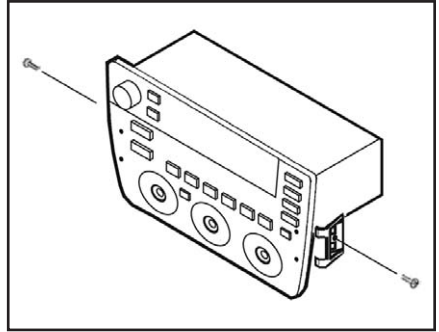

(Figura A)

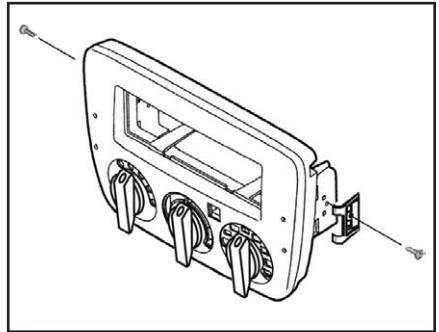

(Figura B)



Ensamble del kit 99-5717

Provisión de unidad central DIN

1. Deslice la reja DIN en el kit integrado de montaje y sujétela doblando hacia abajo las pestañas de metal.
2. Deslice la unidad central de mercado secundario en la reja y sujétela.
3. Ubique el arnés del cableado de fábrica en el tablero. Metra recomienda usar el adaptador de acoplamiento adecuado de Metra o AXCESS. Vuelva a conectar el terminal negativo de la batería y pruebe la unidad para verificar que funcione correctamente.
4. Vuelva a montar el tablero en forma inversa al desmontaje.

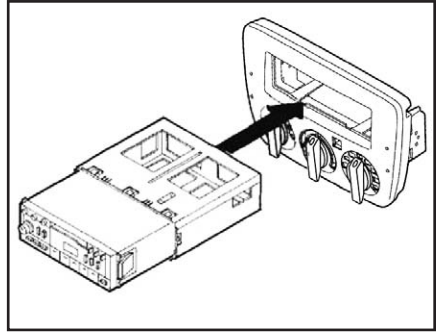

(Figura A)



Ensamble del kit 99-5717

Provisión de unidad central ISO

1. Coloque a presión la placa frontal ISO de la moldura en la apertura del radio.
2. Una los soportes ISO al reborde interior de la apertura del radio.
3. Deslice la unidad central en la apertura del radio; alinee los orificios de la unidad central con los orificios de los soportes ISO.
4. Monte la unidad en los soportes con los tornillos suministrados con la unidad.
5. Ubique el arnés del cableado de fábrica en el tablero. Metra recomienda usar el adaptador de acoplamiento adecuado de Metra o AXCESS. Vuelva a conectar el terminal negativo de la batería y pruebe la unidad para verificar que funcione correctamente.
6. Vuelva a montar el tablero en forma inversa al desmontaje.

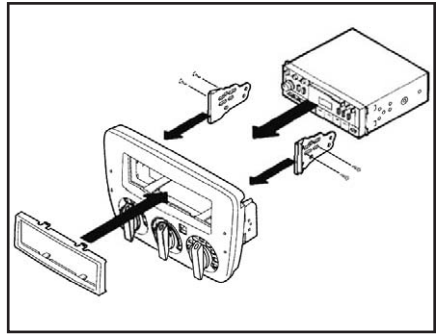

(Figura A)

Información adicional de montaje

1. Abra la cajuela, retire los (4) ganchos a presión del revestimiento de la cajuela del lado del conductor y retire el revestimiento. (Figura A)
2. Localice el sintonizador de fábrica en la pared de la cajuela y desconecte los conectores de la bocina y la antena (esto NO es necesario para retirar el sintonizador). (Figura B)
3. Conecte el 70-5715 en el conector de la bocina de la unidad y el conector de la extensión de la antena en el conector de la antena de la unidad.
4. Deslice el arnés de extensión a través del espacio del asiento trasero entre el respaldo y el asiento.
5. Desenganche la moldura lateral, meta el arnés de extensión debajo de la alfombra y estire el arnés hasta la parte posterior del tablero (vuelva a colocar la moldura lateral cuando termine).
6. Empalme los conectores de la bocina del arnés de extensión en la parte trasera de la unidad central de mercado secundario.
7. Conecte los arneses de cableado de fábrica en los conectores de interrupción y en los conectores de audio en la parte posterior del kit de montaje integrado.
8. Vuelva a conectar la terminal de la batería y pruebe la unidad, los controles de clima y el desempañador trasero para una operación adecuada.
9. Coloque a presión el ensamble del kit de montaje integrado en el sub tablero. (Figura C)

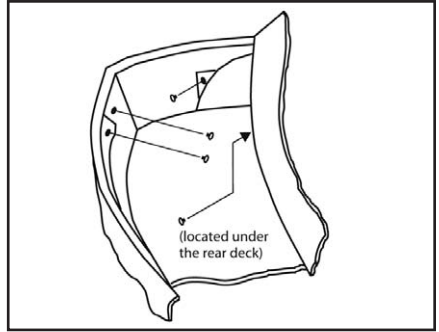

(Figura A)

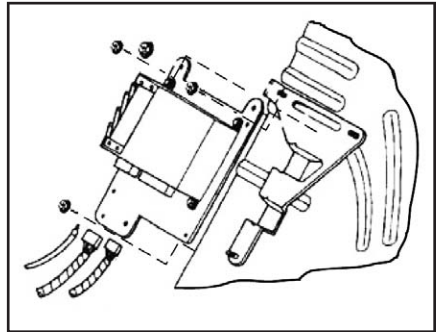

(Figura B)

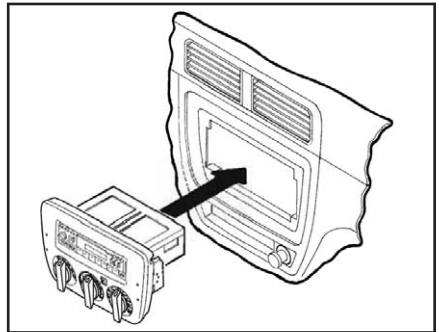

(Figura C)