



INSTALLATION INSTRUCTIONS FOR PART 99-9605B

Porsche 911 (996) 1999-2005 Porsche Boxster (986) 1997-2004 99-9605B

KIT FEATURES

- ISO DIN radio provision with pocket (NAV models only)
- ISO DDIN radio provision
- Provision for HVAC relocation (vehicle must have a lower console)
- **Painted matte black**



KIT COMPONENTS

- A) Radio housing • B) Radio brackets • C) Pocket • D) HVAC trim panel with pocket • E) (6) #8 x 3/8" Phillips screws

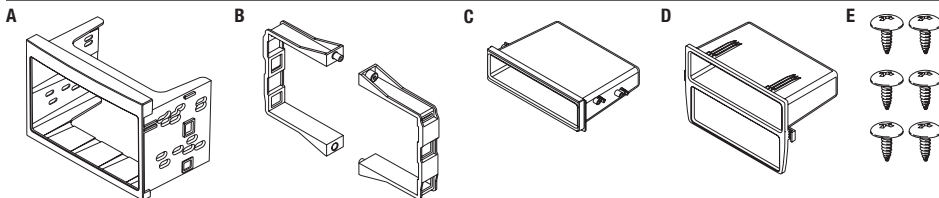

WIRING & ANTENNA CONNECTIONS

- Wiring Harness: • 70-9401 • 70-1787 (amplified models) (sold separately)
 Antenna Adapter: • 40-VW10

Table of Contents

Dash Disassembly	2-4
Kit Preparation	5
Kit Assembly	
– ISO DIN radio provision with pocket.....	6
– ISO DDIN radio provision	7
– Models <i>without</i> factory NAV	7

TOOLS REQUIRED

- Panel removal tool • Phillips screwdriver
- Torx T-20 screwdriver • Cutting tool
- 86-9001 radio removal keys (qty. 2 for NAV models)

CAUTION! All accessories, switches, climate controls panels, and especially air bag indicator lights must be connected before cycling the ignition. Also, do not remove the factory radio with the key in the on position, or while the vehicle is running.

Dash Disassembly

For models *without* factory navigation:

Upper dash:

1. Insert the radio removal keys into the radio until they click in, and then remove the radio. (Figure A)

Note: The curved portion of the radio removal keys should point towards the middle of the radio.

2. Using a panel removal tool, remove the HVAC trim panel. (Figure B)
3. Remove (2) Phillips screws on each side of the HVAC controls, unplug and then remove. (Figure C)

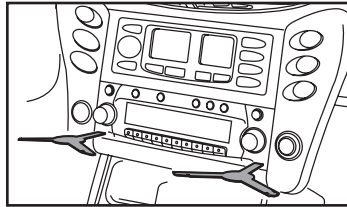

(Figure A)

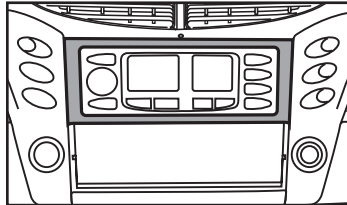

(Figure B)

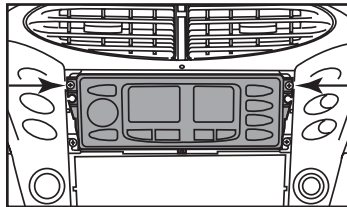

(Figure C)

4. Unsnap and remove the switch panels from each side of the radio opening. (Figure D)

Note: 2002-2005 911 models have one "U" shaped panel instead.

5. Remove (6) Torx T-20 screws securing the radio frame assembly. (Figure E)

Note: The (2) middle screws are located deep in the dash on the sides of the radio opening.

Continued on the next page

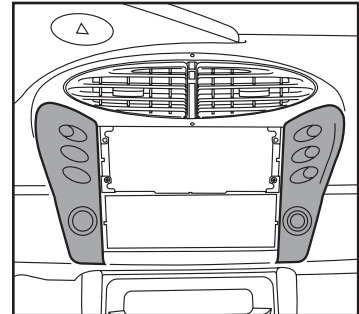

(Figure D)

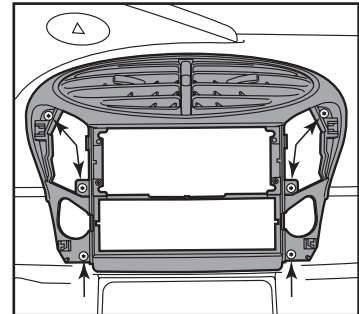

(Figure E)

Dash Disassembly

Lower dash:

6. Unsnap the trim panels from the sides of the lower console. (Figure F)

Note: Unclip from the front of the vehicle, and then pull back.

7. Unsnap and remove the factory CD tray/pocket. (Figure G)

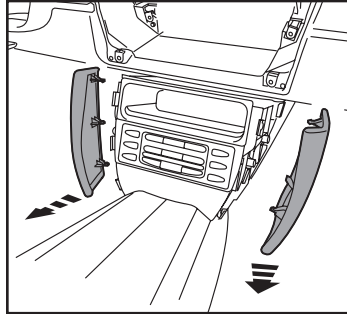

(Figure F)

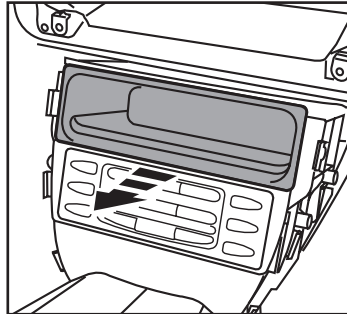

(Figure G)

For models equipped with a DSP controller:

8. The controller will need to be relocated to the inside of the lower dash. The controller must stay connected in order for the factory amplifier to function.
9. Unclip and remove the DSP trim panel. (Figure H)
10. Remove (2) T-20 Torx screws to remove the DSP controller. (Figure I)

Continue to Kit Preparation

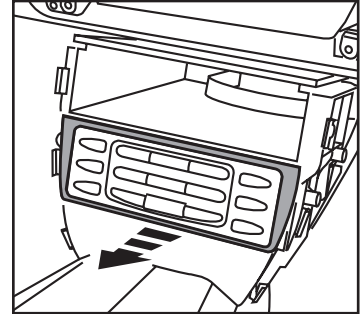

(Figure H)

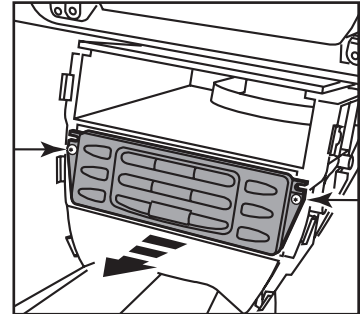

(Figure I)

Dash Disassembly

For models *with* factory navigation:

1. Insert the radio removal keys into the radio until they click in, and then remove the radio. (Figure A)

Note: *The curved portion of the radio removal keys should point towards the middle of the radio.*

2. Unsnap and remove the switch panels from each side of the radio opening. (Figure B)

Note: *2002-2005 911 models have one "U" shaped panel instead.*

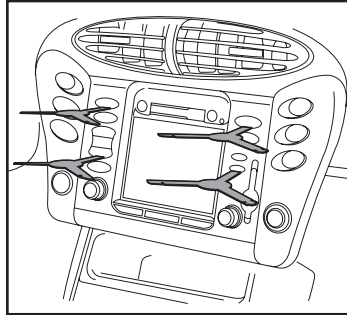

(Figure A)

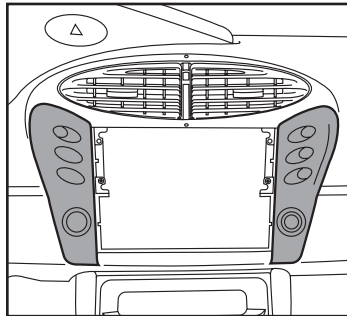

(Figure B)

3. Remove (6) Torx T-20 screws securing the radio frame assembly. (Figure C)

Note: *The (2) middle screws are located deep in the dash on the sides of the radio opening.*

Continue to Kit Assembly

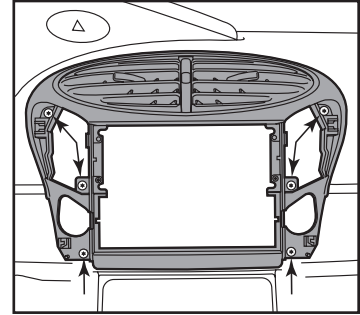

(Figure C)

Kit Preparation

1. Cut and remove the center bar and the mounting positions from the inside of the radio frame assembly removed in dash disassembly to allow room for the radio. (Figure A)
2. Re-route the climate control wiring to the lower console area of the dash.

Continue to kit assembly

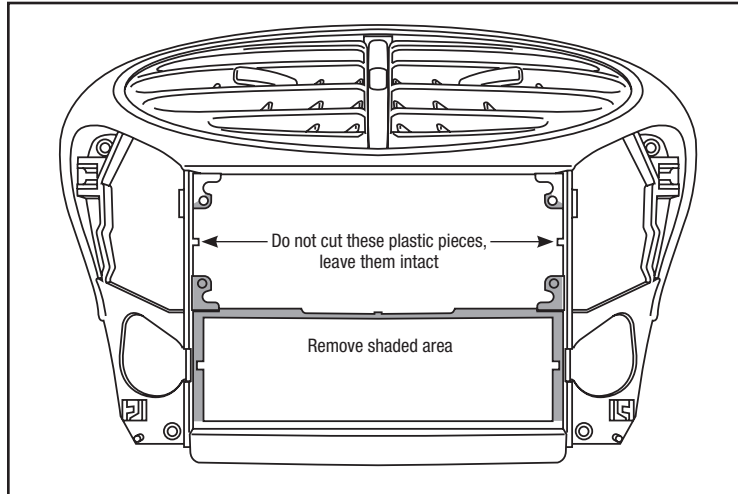

(Figure A)

Kit Assembly

ISO DIN radio provision with pocket (NAV models only)

1. Secure the *pocket* to the *radio housing* using the (4) 8 x 3/8" Phillips screws provided. (Figure A)
2. Remove the metal DIN sleeve and trim ring from the aftermarket radio.
3. Slide the radio into the housing/pocket assembly and then secure it using the screws supplied with the radio. (Figure B)
4. Slide the *radio housing* into the radio frame assembly removed in dash disassembly. (Figure C)

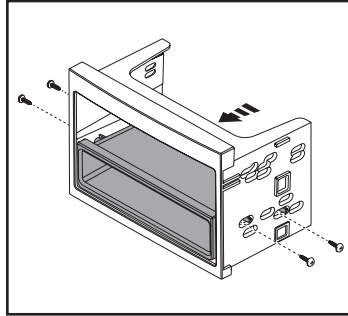

(Figure A)

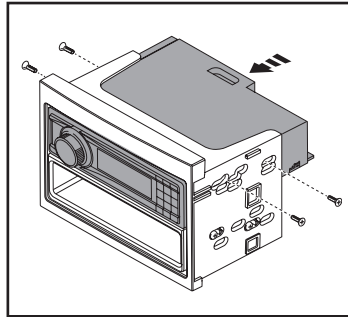

(Figure B)

5. Locate the factory wiring harness and antenna connector in the dash and complete all necessary connections to the radio. Metra recommends using the proper mating adapter from Metra and/or AXCESS. Test the radio for proper operation.
6. Place the *radio brackets* around the radio housing and frame assembly and then secure it using the (2) 8 x 3/8" Phillips screws provided. (Figure D)
7. Reassemble the dash in reverse order of disassembly.

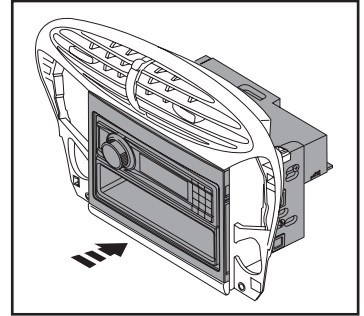

(Figure C)

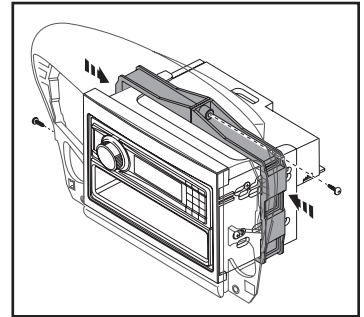

(Figure D)

Kit Assembly

ISO DDIN radio provision

1. Slide the radio into the *radio housing* and then secure it using the screws supplied with the radio. (Figure A)
2. Slide the *radio housing* into the radio frame assembly removed in dash disassembly. (Figure B)
3. Locate the factory wiring harness and antenna connector in the dash and complete all necessary connections to the radio and HVAC controls. Metra recommends using the proper mating adapter from Metra and/or AXCESS. Test the radio for proper operation.
4. Place the *radio brackets* around the radio housing assembly and then secure it using the (2) 8 x 3/8" Phillips screws provided. (Figure C)
5. Reassemble the upper dash in reverse order of disassembly.

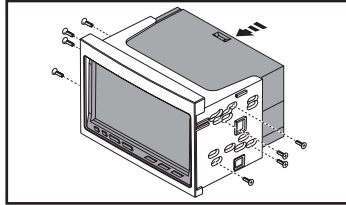

(Figure A)

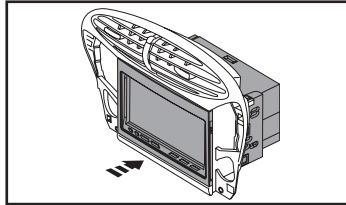

(Figure B)

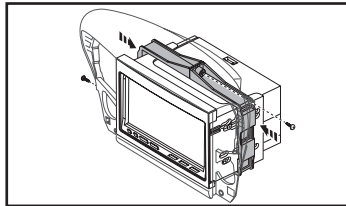

(Figure C)

For models *without* factory navigation:

1. Secure the HVAC controls into the lower location of the lower console using the screws removed in dash disassembly. (Figure A)
2. Snap the *climate trim panel with pocket* into the lower console location. (Figure B)
3. Reassemble the lower dash in reverse order of disassembly.

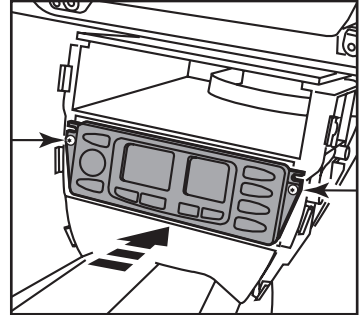

(Figure A)

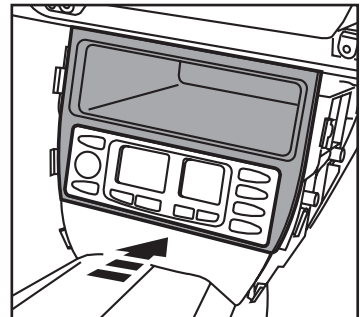

(Figure B)