

Subaru Legacy/Outback (all except 2.5i) 2018-up

KIT FEATURES

- ISO DIN radio provision with pocket
- Painted black with silver trim

KIT COMPONENTS

- A) Radio trim panel • B) Radio brackets • C) Pocket • D) • (4) #8 x 3/8" Phillips screws • E) (4) Panel clips

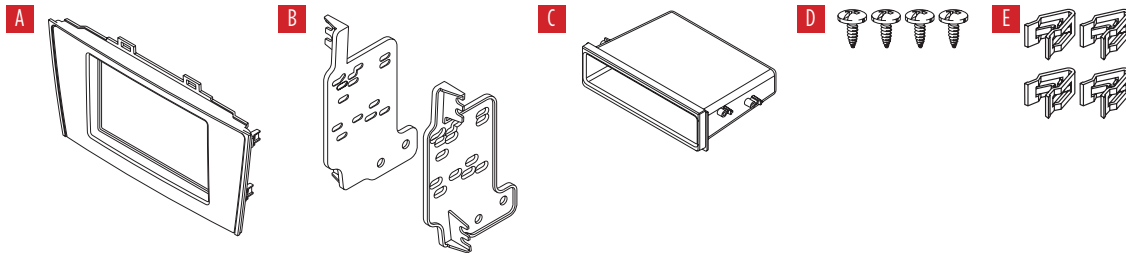

TABLE OF CONTENTS

Dash Disassembly	2
Kit Preparation	3
Kit Assembly	3

WIRING & ANTENNA CONNECTIONS (sold separately)

- Wiring Harness: 70-1761 (non-amplified models)
- Antenna Adapter: 40-LX11

TOOLS REQUIRED

- Panel removal tool • Phillips screwdriver

CAUTION! All accessories, switches, climate controls panels, and especially air bag indicator lights must be connected before cycling the ignition. Also, do not remove the factory radio with the key in the on position, or while the vehicle is running.

DASH DISASSEMBLY

1. Unclip and remove the trim below the climate control panel. (Figure A)
2. Remove (2) Phillips screw securing the climate control panel, then unclip, unplug, and remove the panel. (Figure B)

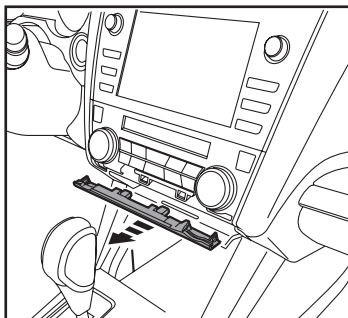

(Figure A)

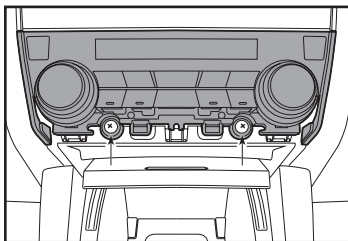

(Figure B)

3. Unclip and remove the a/c vent panel. (Figure C)

Tip! Start from the bottom of the panel and release the bottom (2) clips first.

4. Remove (4) Phillips screws securing the radio, then unclip, unplug and remove the radio. (Figure D, E)

Continue to Kit Preparation

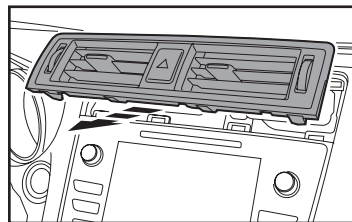

(Figure C)

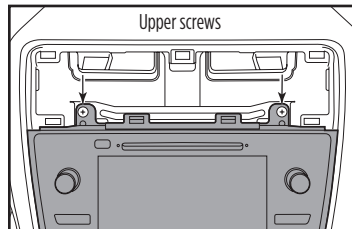

(Figure D)

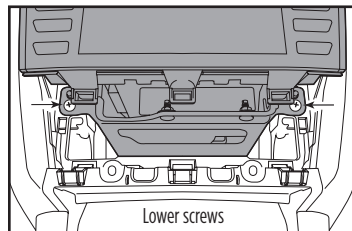

(Figure E)

KIT PREPARATION

1. Slightly loosen (4) screws securing the radio. (Figure A)
2. If the vehicle is equipped with Starlink, remove (4) screws securing the Starlink module (shaded part in figure A) located directly below the radio. The module must be relocated lower in the dash cavity to retain functionality with the front speakers. (Figure A)
3. Remove (4) screws securing the lower module, then remove the module. (Figure A)
4. Secure the module to the *radio brackets* using the factory screws. (Figure B)

Continue to Kit Assembly

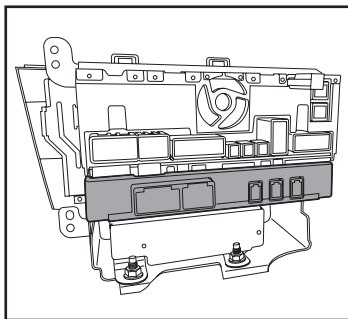

(Figure A)

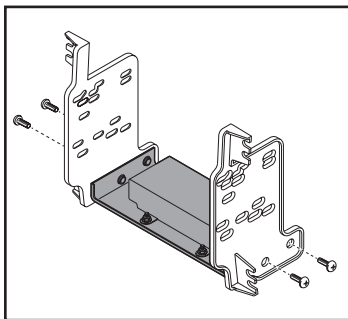

(Figure B)

KIT ASSEMBLY

1. Secure the *pocket* to the *radio brackets* using the (4) #8 x 3/8" Phillips screws provided. (Figure A)
2. Remove the metal DIN sleeve and trim ring from the aftermarket radio.
3. Slide the radio into the bracket/pocket assembly, then secure it using the screws supplied with the radio. (Figure B)
4. Locate the factory wiring harness and antenna connector in the dash and complete all necessary connections to the radio. Metra recommends using the proper mating adapter from Metra and/or Axxess. Test the radio for proper operation.
5. Secure the radio assembly to the dash using the factory screws.
6. Attach the (4) *panel clips* provided to the *radio trim panel*, then snap the panel over the radio assembly.
7. Reassemble the dash in reverse order of disassembly to complete the installation.

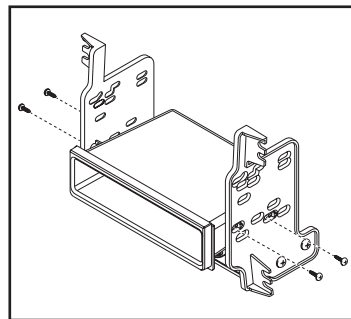

(Figure A)

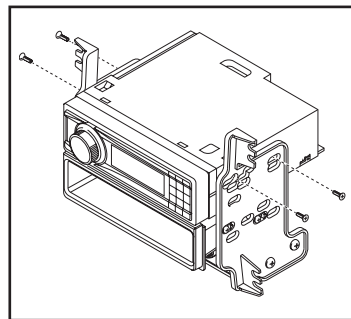

(Figure B)