



### Toyota Prius 2016-up\*

#### KIT FEATURES

- ISO DIN radio provision with pocket
- Painted gloss black

#### KIT COMPONENTS

- A) Radio trim panel • B) Radio brackets • C) Pocket • D) (8) #8 x 3/8" Phillips screws

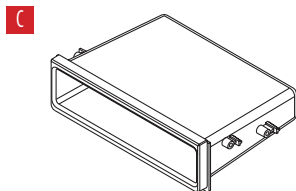
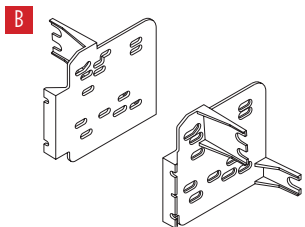
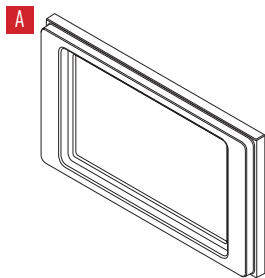

#### TABLE OF CONTENTS

Dash Disassembly .....	2
Kit Assembly .....	3

#### WIRING & ANTENNA CONNECTIONS (sold separately)

Wiring Harness: 70-1761

Antenna Adapter: 40-LX10

#### TOOLS REQUIRED

- Panel removal tool • Phillips screwdriver
- 10mm Socket wrench

**CAUTION!** All accessories, switches, climate controls panels, and especially air bag indicator lights must be connected before cycling the ignition. Also, do not remove the factory radio with the key in the on position, or while the vehicle is running.

## DASH DISASSEMBLY

1. Unclip and remove the trim panel from around the factory radio. (Figure A)
2. Remove (4) 10mm bolts securing the radio, then unplug and remove the radio. (Figure B)

*Continue to Kit Assembly*

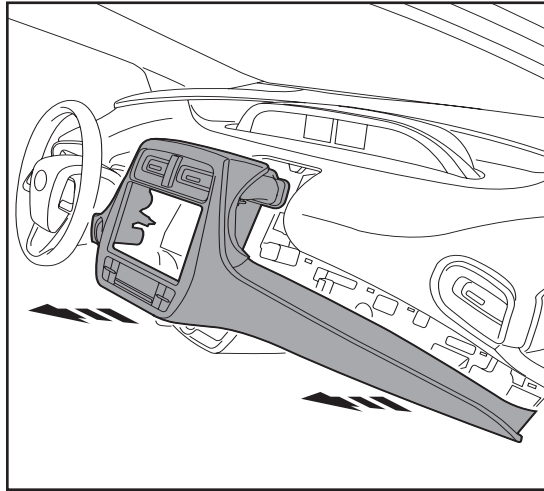

(Figure A)

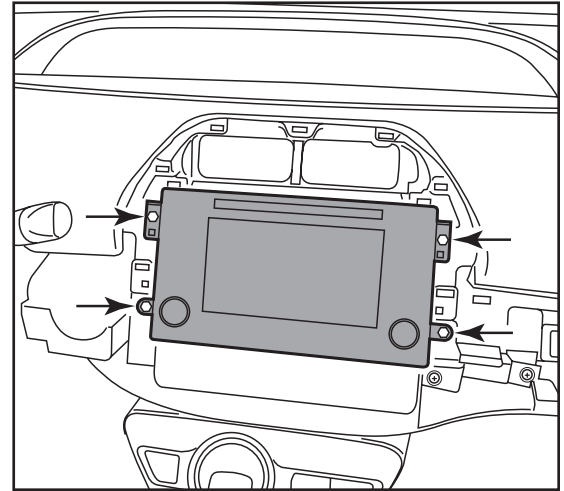

(Figure B)

## KIT ASSEMBLY

1. Attach the *radio brackets* to the *radio trim panel* using the (4) #8 x 3/8" screws supplied. (Figure A)
2. Mount the *pocket* to the *radio brackets* with the (4) #8 x 3/8" Phillips screws supplied. (Figure B)
3. Remove the metal DIN sleeve and trim ring from the aftermarket radio.
4. Slide the radio into the assembly and secure with the screws supplied with the radio. (Figure C)

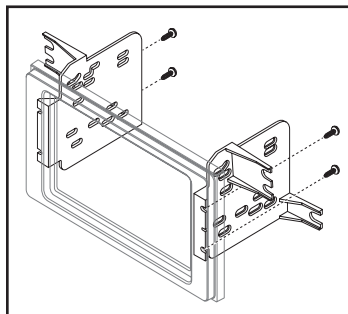

(Figure A)

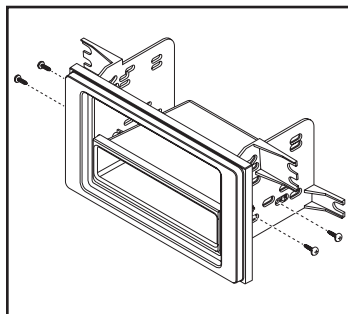

(Figure B)

5. Locate the factory wiring harness and antenna connector in the dash and complete all necessary connections to the radio. Metra recommends using the proper mating adapter from Metra. Test the radio for proper operation.
6. Secure the radio/bracket assembly to the vehicle using the factory hardware, and then reassemble the dash in reverse order of disassembly.

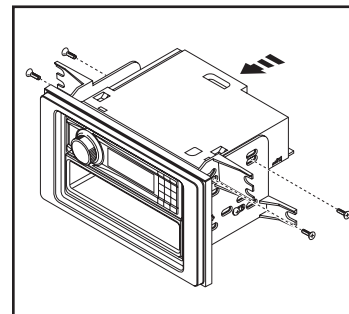

(Figure C)