



Ford Edge 2011-2014 (with 4.3" screen, without Ford MyTouch)

KIT FEATURES

- ISO DIN radio provision with pocket
- ISO DDIN radio provision
- Touchscreen display for climate and personalization features
- Included interface for audio, climate and steering wheel functions
- Painted Charcoal Gray

KIT COMPONENTS

- A) Radio trim panel • B) Radio brackets • C) Pocket • D) (4) #8 x 3/8" Phillips screws for pocket • E) (2) Panel Clips • F) Antenna adapter (not shown)

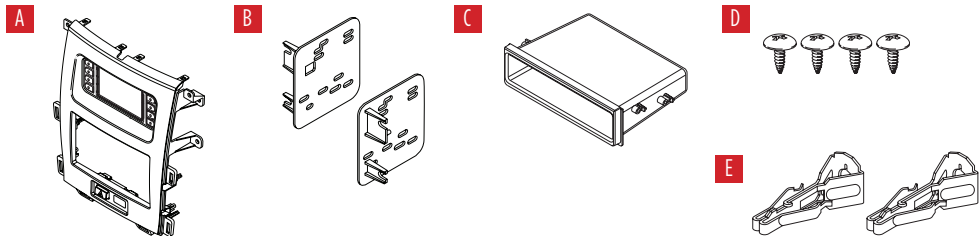

TABLE OF CONTENTS

Dash Disassembly.....	2-3
Kit Assembly	
–ISO DIN radio provision with pocket.....	4
–ISO DDIN radio provision.....	4
Axxess Interface Installation.....	5-13

WIRING & ANTENNA CONNECTIONS

- Wiring Harness: Included
- Antenna Adapter: Included

TOOLS REQUIRED

- Panel removal tool • Phillips screwdriver
- Socket wrench • Torx screwdrivers

CAUTION! All accessories, switches, climate controls panels, and especially air bag indicator lights must be connected before cycling the ignition. Also, do not remove the factory radio with the key in the on position, or while the vehicle is running.

DASH DISASSEMBLY

Attention! The factory radio must be powered off before starting disassembly. Omitting this step will disable the menu function.

1. Unclip and remove the (2) trim panels from the left and right side of the factory radio. (Figure A)
2. Unclip and remove the trim panel around the shifter and slide toward back of console. (Figure B)
3. Remove (6) 9/32" screws securing the radio/climate control panel to the dash. (Figure C)

Continued on the next page

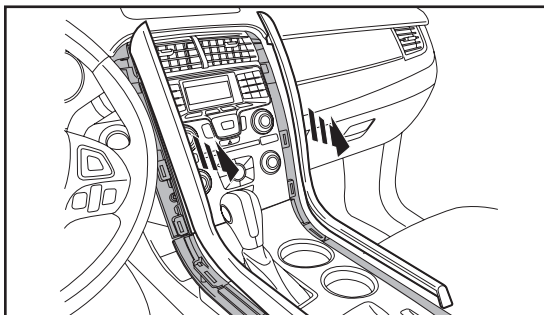

(Figure A)

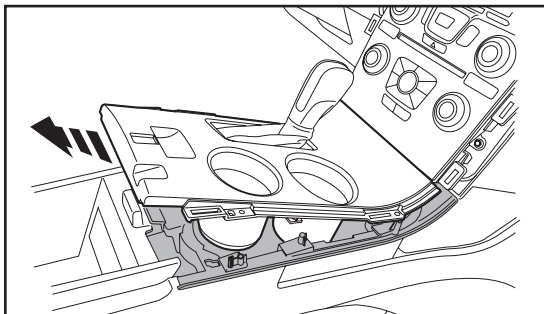

(Figure B)

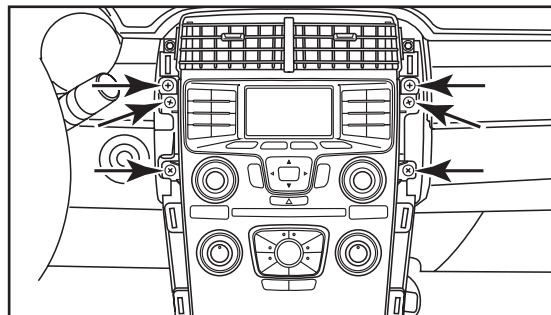

(Figure C)

DASH DISASSEMBLY (CONT)

4. Unclip and remove the factory radio/ climate control panel. (Figure D)
5. Remove (4) 9/32" screws securing the radio chassis. (Figure E)
6. Remove (4) 9/32" screws securing the factory display. (Figure E)
7. Remove (4) 9/32" screws securing the display to the display brackets and keep display for kit assembly. (Figure F)

Continue to Kit Assembly

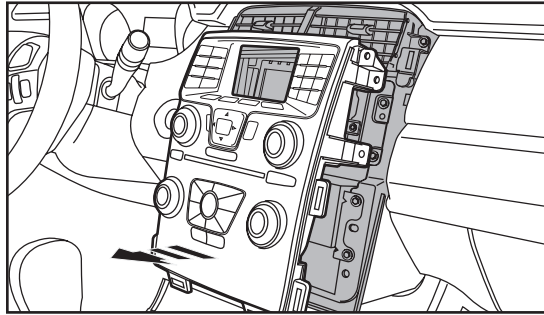

(Figure A)

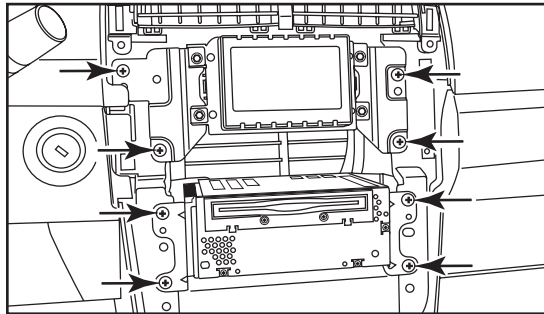

(Figure B)

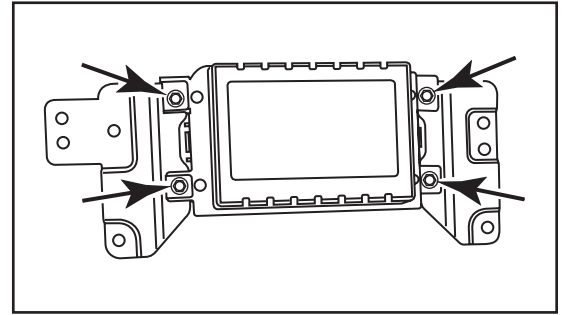

(Figure C)

KIT ASSEMBLY

ISO DIN radio provision with pocket

1. Attach the provided *panel clips* to the *radio trim panel*. The factory clips may be used if desired.
2. Secure the *pocket* to the *radio brackets* using the screws supplied with the radio. (Figure A)
3. Slide the aftermarket radio into *radio brackets* and secure with the screws supplied with the radio. (Figure A)

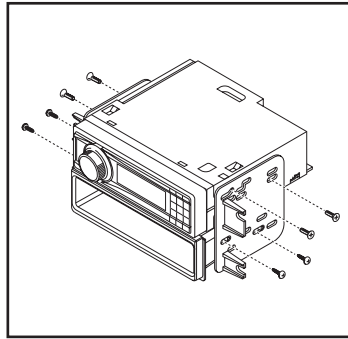

(Figure A)

ISO DDIN radio provision

1. Attach the provided *panel clips* to the *radio trim panel*. The factory clips may be used if desired.
2. Secure the radio to the radio brackets using the screws supplied with the radio. (Figure A)

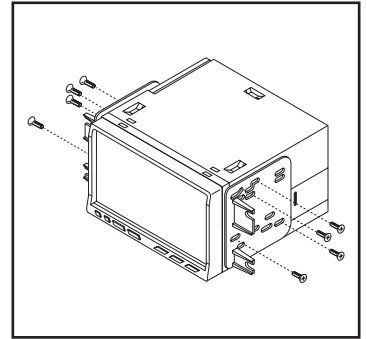

(Figure A)

AXXESS INTERFACE INSTALLATION

INTERFACE FEATURES

- Provides accessory power (12-volt 10-amp)
- Retains R.A.P. (retained accessory power)
- Provides NAV outputs (parking brake, reverse, speed sense)
- Retains audio controls on the steering wheel
- Retains SYNC® (4.2-inch display screen models only)
- Retains the factory backup camera
- Retains balance and fade
- Micro “B” USB updatable

INTERFACE COMPONENTS

- Axxess interface (built into the touchscreen display)
- 5848 harness
- 4-pin flat to 4-pin stacked harness
- 16-pin harness with stripped leads
- 12-pin backup camera harness
- 4-pin harness with yellow RCA jacks
- Female 3.5mm connector with stripped leads

TABLE OF CONTENTS

Connections to be made	6-7
Installing the interface	8
Initializing the interface	8
Final assembly	8
Touchscreen display operation	9-11
Steering wheel control settings	12-13

TOOLS REQUIRED

- Wire cutter • Crimp tool • Solder gun • Tape
- Connectors (example: butt-connectors, bell caps, etc.)

CONNECTIONS TO BE MADE

From the 16-pin harness with stripped leads to the aftermarket radio:

- Connect the **Red** wire to the accessory wire.
- If equipped with a factory subwoofer, connect the **Blue/White** wire to the amp turn on wire.
- If the aftermarket radio has an illumination wire, connect the **Orange/White** wire to it.
- If the aftermarket radio has a mute wire, and the vehicle is equipped with SYNC®, connect the **Brown** wire to it. If the mute wire is not connected, the radio will turn off when SYNC® is activated.
- Connect the **Gray** wire to the right front positive speaker output.
- Connect the **Gray/Black** wire to the right front negative speaker output.
- Connect the **White** wire to the left front positive speaker output.
- Connect the **White/Black** wire to the left front negative speaker output.
- Tape off and disregard the following (4) wires, they will not be used in this application: **Green, Green/Black, Purple, Purple/Black**

The following (3) wires are only for multimedia/navigation radios that require these wires.

- Connect the **Blue/Pink** wire to the VSS/speed sense wire.
- Connect the **Green/Purple** wire to the reverse wire.
- Connect the **Light Green** wire to the parking brake wire.

From the 5848 harness to the aftermarket radio:

- Connect the **Black** wire to the ground wire.
- Connect the **Yellow** wire to the battery wire.
- Connect the **Green** wire to the left rear positive speaker output.
- Connect the **Green/Black** wire to the left rear negative speaker output.
- Connect the **Purple** wire to the right rear positive speaker output.
- Connect the **Purple/Black** wire to the right rear negative output.
- Tape off and disregard the following (1) wire, it will not be used in this application: **Blue**
- **For models with a 4.2-inch display screen and SYNC®:** Connect the **Red** and **White** RCA jacks labeled “RSE/SYNC/SAT” to the audio AUX-IN jacks of the aftermarket radio.
- **For models equipped without SYNC®:** Connect the **Red** and **White** RCA jacks labeled “FROM 3.5” to the audio AUX-IN jacks of the aftermarket radio.

Continue to 3.5mm jack steering wheel control retention

3.5mm jack steering wheel control retention:

- The 3.5mm jack is to be used to retain audio controls on the steering wheel control.
 - For the radios listed below, connect the included *female 3.5mm connector with stripped leads*, to the male 3.5mm SWC jack from the 5848 harness. Any remaining wires tape off and disregard:
 - **Eclipse:** Connect the steering wheel control wire, normally **Brown**, to the **Brown/White** wire of the connector. Then connect the remaining steering wheel control wire, normally **Brown/White**, to the **Brown** wire of the connector.
 - **Metra OE:** Connect the steering wheel control Key 1 wire (**Gray**) to the **Brown** wire.
 - **Kenwood or select JVC with a steering wheel control wire:** Connect the **Blue/Yellow** wire to the **Brown** wire.

Note: *If your Kenwood radio auto detects as a JVC, manually set the radio type to Kenwood. See the instructions under changing radio type.*
 - **XITE:** Connect the steering wheel control SWC-2 wire from the radio to the **Brown** wire.
 - **Parrot Asteroid Smart or Tablet:** Connect the 3.5mm jack into the AX-SWC-PARROT (sold separately), and then connect the 4-pin connector from the AX-SWC-PARROT into the radio.

Note: *The radio must be updated to rev. 2.1.4 or higher software.*
 - **Universal “2 or 3 wire” radio:** Connect the steering wheel control wire, referred to as Key-A or SWC-1, to the **Brown** wire of the connector. Then connect the remaining steering wheel control wire, referred to as Key-B or SWC-2, to the **Brown/White** wire of the connector. If the radio comes with a third wire for ground, disregard this wire.

Note: *After the interface has been programmed to the vehicle, refer to the manual provided with the radio for assigning the SWC buttons. Contact the radio manufacturer for more information.*
 - **For all other radios:** Connect the 3.5mm jack into the port on the radio designated for an external steering wheel control interface. Refer to the manual provided with the radio if in doubt as to where the 3.5mm jack goes to.

Backup camera harness:

For models with a 4.2-inch display screen:

- Use the 12-pin backup camera harness.

There are two different methods for connecting the factory backup camera.

If retaining the camera to the aftermarket radio is desired:

- Connect the **Yellow** RCA jack the backup camera input of the aftermarket radio.

If retaining the camera to the touchscreen display is desired:

- Connect the **Yellow** RCA jack, to the **Yellow** RCA jack from the 4-pin harness with yellow RCA jacks labeled “Rearview camera”.

Note: *If this method is chosen, the backup camera option must be enabled in the Configuration Settings Screen.*

4-pin harness with yellow RCA jacks:

- If retaining the factory backup camera to the touchscreen display is desired, connect the **Yellow** RCA jack labeled “Rearview camera”, to the **Yellow** RCA jack from the 12-pin or 54-pin backup camera harness.
- Disregard the **Yellow** RCA jack labeled “AUX video”, it will not be used in this application.

INSTALLING THE INTERFACE

It is highly advisable to read the following steps beforehand, to ensure a clear understanding of what is to be expected. The following steps must be done in the order that they are numbered.

With the vehicle completely off:

Touchscreen display

1. Connect the 16-pin harness with stripped leads into port “B” in the touchscreen display.
2. Connect the 5848 harness to the wiring harnesses in the vehicle. These harnesses are the ones removed in step 7 of dash disassembly. Then insert the 5848 harness into port “A” in the touchscreen display. But do not install this harness until exactly before step 1 of “Initializing the Interface”. This is a timed process.
3. Connect the 4-pin harness with yellow RCA jacks into port “C” in the touchscreen display.
4. Disregard ports “D” and “E”, they will not be used in this application.
5. Port “F” is an update port for future firmware upgrades.

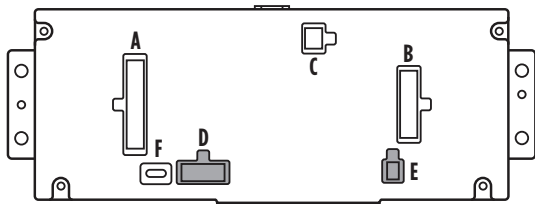

INITIALIZING THE INTERFACE

Attention! If the interface loses power for any reason, the following steps will need to be performed again.

1. Refer to step 2 of “Installing the interface”.
2. Place the vehicle ignition to the on position.
3. Program the kit:
 - a. Once the touchscreen display loads up, select the vehicle type.
 - b. Wait until the radio comes on, and the touchscreen display shows “SWC Configured*”. This process may take up to 3 minutes.

Note: If the touchscreen display does not load up, or the radio doesn't come on within 3 minutes, and/or the touchscreen display does not show “SWC Configured*”, turn the vehicle off and disconnect the harness from port “A” in the touchscreen display. Check all the connections, reconnect the harness into the touchscreen display, and then try again.

* For models with steering wheel controls.

4. Test all functions of the installation for proper operation, before reassembling the dash.

FINAL ASSEMBLY

1. Secure the completed assembly into the dash using the factory hardware.
2. Snap the radio trim panel with touchscreen display over the completed assembly, and then reassemble the dash in reverse order of disassembly.

TOUCHSCREEN DISPLAY OPERATION

HVAC Control screen

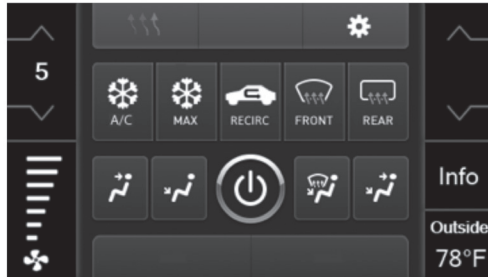

Manual climate controls



Automatic climate controls

- This is the HVAC control screen which will be displayed on the touchscreen display. This is considered the main screen.
- The upper left tab with (3) arrows will take you to the **Heated/Cooled** seats screen, if applicable.
Note: *This screen will also include Heated Steering if applicable.*
- The upper right tab with the gear icon will take you to the **Configuration Settings** screen.
- **Auto climate models:** The climate controls will function in the same manner that they did with the factory climate controls.
- **Manual climate models:** The climate controls will function in the same manner that they did with the factory climate controls, yet via touchscreen buttons instead. The temperature control will display a numerical scale, with “LO” being the coldest, and “HI” being the hottest: LO / 1-9 / HI
Note: *The “Info” button will only be shown if SYNC is to be retained.*

Continued on the next page

Configuration Settings screen

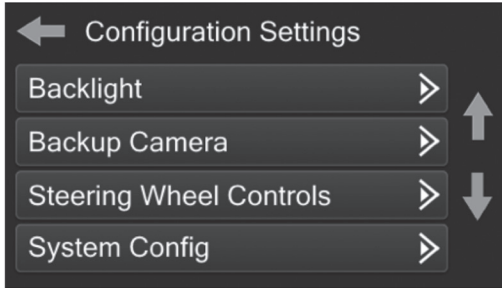

- **System Configuration**
 - Firmware version
- **System Configuration**
- **Touchscreen calibration**
 - Press and hold the upper two soft buttons on either side of the touchscreen for 10 seconds.
 - A screen will pop up asking for you to press the target in the screen.
 - After pressing the target with your finger, the calibration process will be complete, and the screen will disappear.
- **Backlight**
 - Four slide bars control the color of the buttons and the back-light intensity:
Red / Green / Blue / Backlight
- **Backup Camera**
 - Enable – Enables the backup camera image to the touchscreen display
 - Disable – Disables the backup camera image to the touchscreen display (default)
- **Steering Wheel Controls**
 - Remap Buttons – For remapping the steering wheel control buttons
 - Dual Assign – For dual assigning the steering wheel control buttons (long button press)
 - Select Radio – For auto detecting the radio, or changing the radio type

Continued on the next page

Digital Amp Gain screen

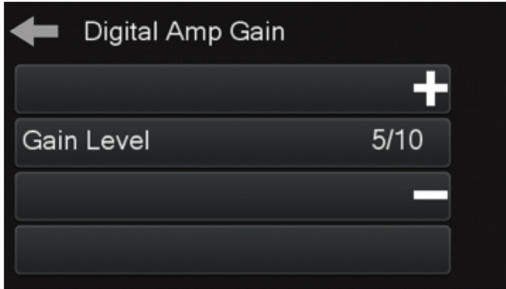

- If it is found that the volume on a Digital Amp system is too low, this option should be used to adjust the output to the amplifier.
- The middle line will indicate where the level is based on a 1-10 level.
- Press the “+” to increase the overall volume
- Press the “-“ to decrease the overall volume

STEERING WHEEL CONTROL SETTINGS

Select Radio screen



- To show which brand radio is “auto detected” to the interface, press the “Autodetect” button. The radio detected will have a filled in circle. If the incorrect radio is shown, select the proper radio.
- Following is a list of radio manufacturers that the interface presently acknowledges. Others may be added at a later date. Universal “2 or 3 wire” radios can show up as any of these radio manufacturers.

Eclipse (Type 1) †	Pioneer/Jensen	Clarion (Type 2) †	Parrot **
Kenwood ‡	Alpine *	Metra OE	XITE
Clarion (Type 1) †	Visteon	Eclipse (Type 2) †	Phillips
Sony / Dual	Valor	LG	JBL
JVC			

*** Note:** If the interface shows an Alpine radio, and you do not have an Alpine radio, that means the interface does not detect a radio connected to it, i.e., an open connection. Verify that the 3.5mm jack is connected to the correct steering wheel jack/wire in the radio.

**** Note:** The AX-SWC-PARROT is required (sold separately). Also, the Parrot radio must be updated to rev. 2.1.4.

† Note: If you have a Clarion radio and the steering wheel controls do not work, change the radio type to the other Clarion radio type; same for Eclipse.

‡ Note: If you have a Kenwood radio and the touchscreen display shows a JVC radio, change the radio type to Kenwood.

Continued on the next page

STEERING WHEEL CONTROL SETTINGS (CONT.)

Remap Button screen

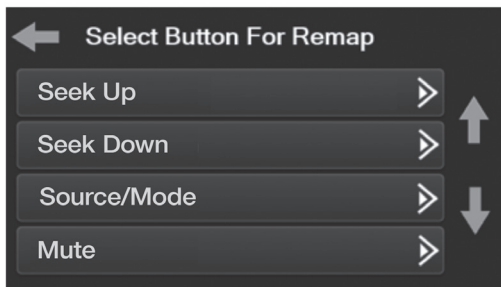

- The interface has the ability to change the button assignment for the steering wheel control audio buttons, except Volume-Up and Volume-Down. Follow the prompts on the touchscreen display to remap the steering wheel control audio button(s) to your liking.

Note: The aftermarket radio may not have all of these commands. Please refer to the manual provided with the radio, or contact the radio manufacturer, for specific commands recognized by that particular radio.

Dual Assign screen

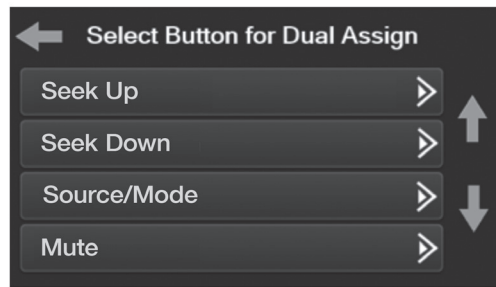

- The interface has the capability to assign two functions to a single button, except Volume-Up and Volume-Down. Follow the prompts on the touchscreen display to program the button(s) to your liking.

Note: Seek-Up and Seek-Down come programmed as Preset-Up and Preset-Down for a long button press.