

## KIT COMPONENTS

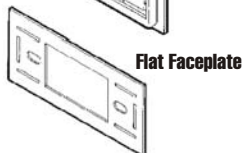

## TOOLS REQUIRED

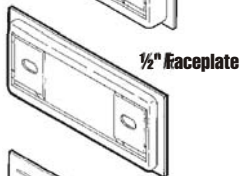
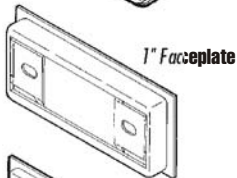
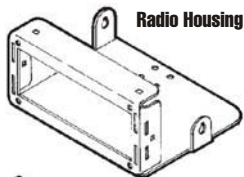

Phillips screwdriver



Cutting tool



# 99-4012 INSTALLATION INSTRUCTIONS

## APPLICATIONS

GENERAL MOTORS 1982-02  
VEHICLES EQUIPPED WITH J-2000 PANEL-STYLE  
FACTORY HEAD UNIT PROVISIONS  
(SEE INSIDE FOR SPECIFIC APPLICATIONS)



## APPLICATIONS

<b>BUICK</b>	<b>CHEVROLET (cont.)</b>	<b>CHEVROLET (cont.)</b>	<b>OLDSMOBILE (cont.)</b>
Century 1982-96*	Camaro 1997-99	Suburban 1989-91*	Ninety Eight 1984-90*
Electra 1984-94*	Caprice 1991-93*	Suburban 1995-02	Omega 1983-84*
Estate wagon 1984-94*	Caprice 1994-96	Tahoe 1995-02	Silhouette 1990-95*
LeSabre 1984-94*	Cavalier 1982-90*	Van (full) 1988-95*	Silhouette 1996*
Park Ave. 1984-94*	Cavalier 1991-94*	Venture 1997-99	Silhouette 1997-99
Reatta 1990-91*	Cavalier 1995-99	<b>GMC</b>	Toronado 1982-85*
Regal 1984-87*	Celebrity 1982-83*	Jimmy (full) 1989-91*	<b>PONTIAC</b>
Riviera 1983-85*	Celebrity 1984-87*	Jimmy 1998-02	6000 1982-91*
Riviera 1990-95*	Citation II 1985*	S15 Jimmy 1982-85*	Bonneville 1982-86*
Roadmaster 1991-94*	Corsica 1991-96*	S15 Jimmy 1986-94*	Bonneville 1987-93*
Skyhawk 1982-89*	Corvette 1984-89*	S15 Pickup 1982-85*	Bonneville 1994-99
Skylark 1983-85*	Corvette 1997-02	S15 Pickup 1986-93*	Fiero 1984-88*
Skylark 1987-89*	El Camino 1985-88*	Safari 1985-89*	Firebird 1982-84*
Skylark 1990-95*	Express 1996-00	Safari 1990-95*	Firebird 1985-92*
<b>CADILLAC</b>	Impala SS 1994-96	Safari 1996-02	Firebird 1993-02
Cimarron 1982-88*	Lumina 1990-94*	Savana 1996-00	Grand Am 1985-91*
DeVille 1985-93*	Lumina 1995-99	Sierra 1995-02	Grand Am 1992-95*
Eldorado 1984-91*	Lumina APV 1990-95*	Sonoma 1998-02	Grand Am 1996-98
Escalade 1999-02	Lumina APV 1996*	Suburban 1989-91*	Grand Am 1999-00
Fleetwood 1985-93*	Malibu 1997-99	Suburban 1995-99	Grand Prix 1985-87*
Seville 1984-91*	Monte Carlo 1985-88*	Van (full) 1988-95*	Grand Prix 1990-93*
<b>CHEVROLET</b>	Monte Carlo 1995-99	Yukon 1995-02	Grand Prix 1994-96
Astro 1985-89*	Nova 1985-88*	<b>OLDSMOBILE</b>	Grand Prix 1997-00
Astro 1990-95*	Pickup 1995-02	Achieva 1992-95*	Montana 1999
Astro 1996-02	S10 Blazer 1982-85*	Bravada 1991-94*	Sunbird J-2000 1982-88*
Beretta 1991-96*	S10 Blazer 1986-94*	Cutlass Calais 1984-91*	Sunfire 1995-99
Blazer (full) 1989-91*	S10 Pickup 1982-85*	Cutlass Ciera 1982-96*	TransSport 1990-95*
Blazer 1998-02	S10 Pickup 1986-93*	Cutlass Supr. 1984-88*	TransSport 1996*
Camaro 1982-84*	S10 Pickup 1998-02	Delta 88 1986-88*	TransSport 1997-98
Camaro 1985-92*	Silverado 1999-02	Firenza 1982-89*	<b>SATURN</b>
			(all models) 1991-94*

\* THE FACTORY MOUNTING BRACKET(S) MUST BE RETAINED AND USED WITH THIS VEHICLE.

## ALL VEHICLES

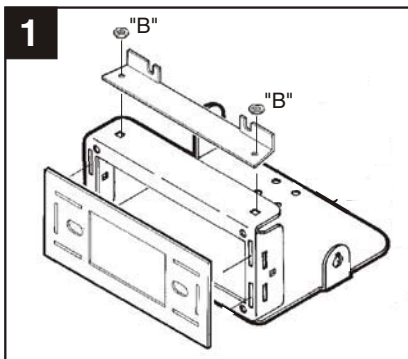

Please call Metra's Technical Support line for individual dash disassemblies.

Mount the Metra bracket(s)  
OR factory bracket(s) to the Housing with Carriage Bolts and Keps Nuts supplied ("B"). Choose the desired Faceplate and snap it onto the front of the Radio Housing.

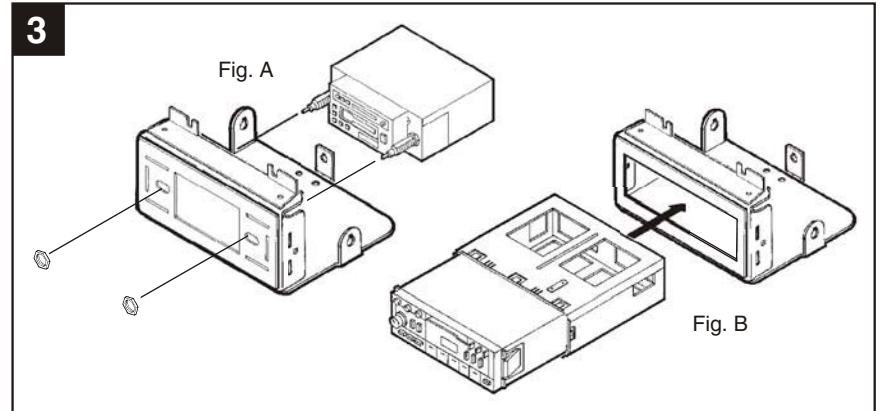
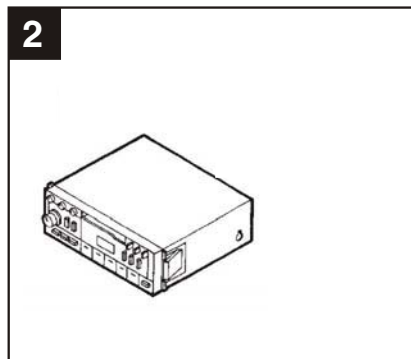

**2-SHAFT HEAD UNITS:** Slide the aftermarket head unit into the kit and secure with shaft nuts. (see Fig. A).

**DIN HEAD UNITS:** Cut and remove the shaft supports from the Faceplate. Slide the DIN cage into the Radio Housing and secure by bending the metal locking tabs down. Slide the aftermarket head unit into the cage until secure. (see Fig. B).

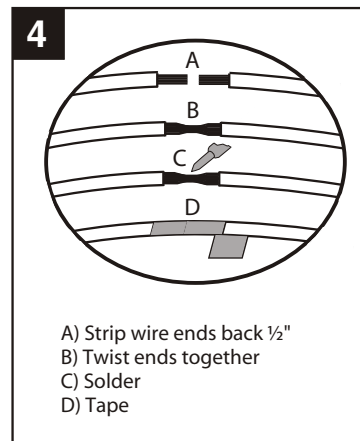

Locate the factory wiring harness in the dash. Metra recommends using the proper mating adaptor and making connections as shown. (Isolate and individually tape off the ends of any unused wires to prevent electrical short circuit).

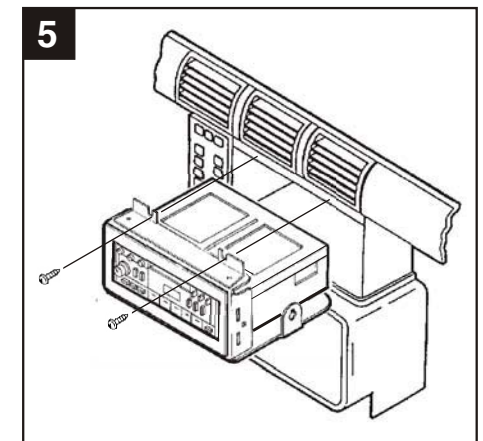

Re-connect the battery terminal and test the unit for proper operation. Mount the head unit/kit assembly to the sub-dash with those screws previously removed.