



## Mercedes-Benz S Class 2000-2006

### KIT FEATURES

- ISO DDIN radio provision
- 95-8726B-Finished in black
- 95-8726W-Finished in woodgrain

### KIT COMPONENTS

- A) Radio trim panel • B) Radio brackets

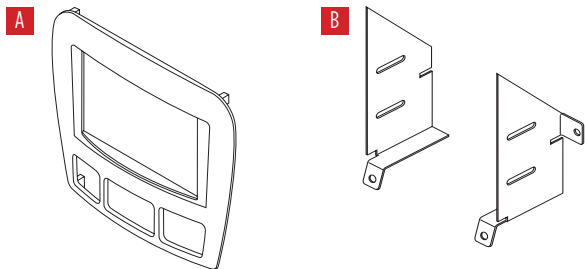

### TABLE OF CONTENTS

Dash Disassembly .....	2
Kit Preparation .....	2
Kit Assembly .....	3

### WIRING & ANTENNA CONNECTIONS (sold separately)

Wiring Harness: TBA

Antenna Adapter: 40-VW12

### TOOLS REQUIRED

- Panel removal tool • Phillips screwdriver
- Torx T20 screwdriver

**CAUTION!** All accessories, switches, climate controls panels, and especially air bag indicator lights must be connected before cycling the ignition. Also, do not remove the factory radio with the key in the on position, or while the vehicle is running.

## DASH DISASSEMBLY

### 2000-2002

1. Open the ashtray compartment door, remove (2) Torx T20 screws securing the ashtray assembly, then remove and unplug the ashtray assembly.
2. Unclip, unplug, and remove the climate control panel surrounding the radio, then remove the panel.
3. Remove (4) Torx T20 screws securing the radio, then unplug and remove the radio.

### 2003-2006

1. Open the ashtray compartment door, remove (2) Torx T20 screws securing the ashtray assembly, then remove and unplug the ashtray assembly.
2. Unclip, unplug, and remove the climate control panel, then remove the panel.
3. Unclip and remove the trim panel above the radio.
4. Remove (4) Torx T20 screws securing the radio, then unplug and remove the radio.

*Continue to Kit Preparation*

## KIT PREPARATION

1. Remove (2) Torx T20 screws securing the climate controls to the climate control panel, then remove the climate controls.
2. Secure the climate controls the *radio trim panel* using the factory screws.

*Continue to Kit Assembly*

## KIT ASSEMBLY

1. Secure the *radio brackets* to the radio using the screws provided with the radio. (Figure A)
2. Locate the factory wiring harness and antenna connection in the dash, and complete all necessary connections to the radio. Metra recommends using the proper mating adapter from Metra and/or Axxess. Test the radio for proper operation.
3. Secure the radio to the dash using the (2) factory screws, to just the lower tabs on the *radio brackets*. (Figure B)
4. Connect the factory climate control harness to the climate controls, then clip the *radio trim panel* onto the dash.
5. Reassemble the ashtray assembly in reverse order of disassembly to complete the installation.

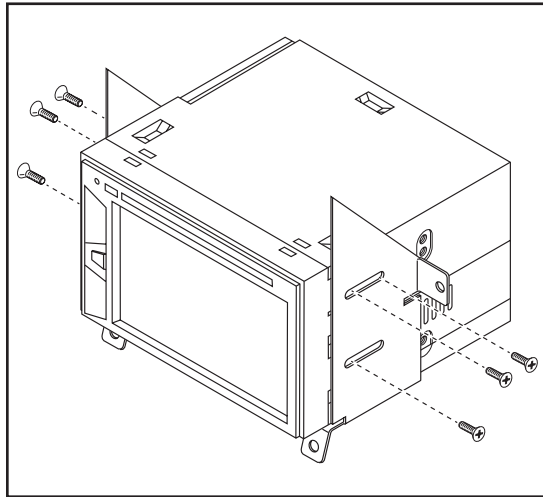

(Figure A)

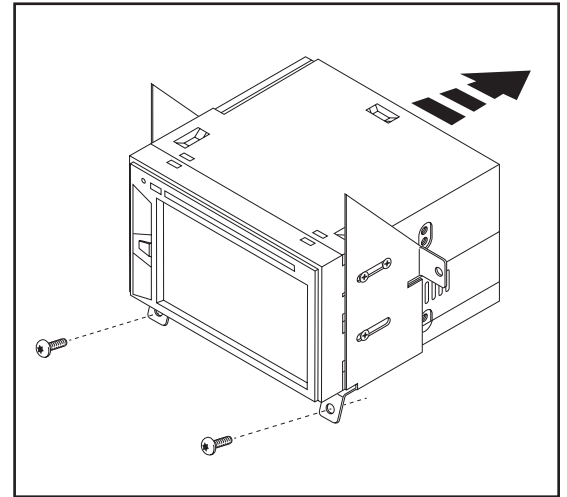

(Figure B)