



Toyota C-HR 2018-up

KIT FEATURES

- ISO DIN radio provision with pocket
- Painted high gloss black

KIT COMPONENTS

- A) Radio housing trim panel • B) Radio brackets • C) Pocket • D) (4) #6 x 3/8" Phillips screws • E) (2) #8 x 3/8" Phillips screws

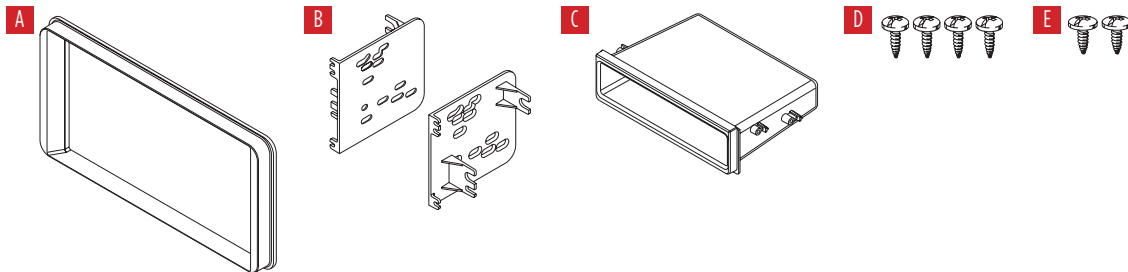

TABLE OF CONTENTS

Dash Disassembly.....	2
Kit Assembly	
- ISO DIN radio provision with pocket.....	3

WIRING & ANTENNA CONNECTIONS (sold separately)

Wiring Harness: 70-1761

Antenna Adapter: 40-LX10

TOOLS REQUIRED

- Panel removal tool • Phillips screwdriver
- 10mm socket wrench

CAUTION! All accessories, switches, climate controls panels, and especially air bag indicator lights must be connected before cycling the ignition. Also, do not remove the factory radio with the key in the on position, or while the vehicle is running.

DASH DISASSEMBLY

1. Unclip and remove the trim panel from around the factory radio, including the clock. (Figure A)
2. Remove (4) 10mm bolts securing the radio, then remove it. (Figure B)

Continue to Kit Assembly

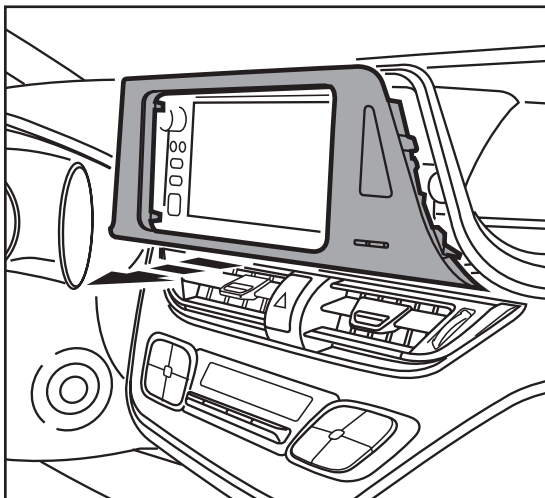

(Figure A)

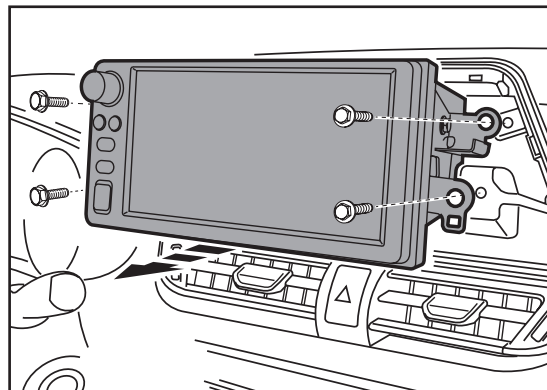

(Figure B)

KIT ASSEMBLY

ISO DIN radio provision with pocket

1. Attach the *radio brackets* to the *radio housing trim panel* using the (4) #6 x 3/8" screws supplied. (Figure A)
2. Mount the *pocket* to the *radio brackets* with the (2) #8 x 3/8" Phillips screws supplied. (Figure B)
3. Remove the metal DIN sleeve and trim ring from the aftermarket radio.
4. Slide the radio into the assembly and secure with the screws supplied with the radio. (Figure C)

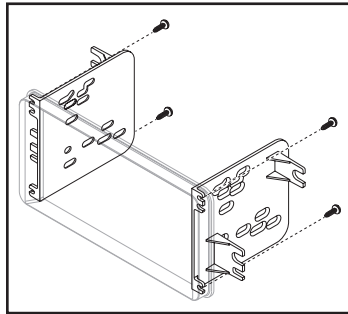

(Figure A)

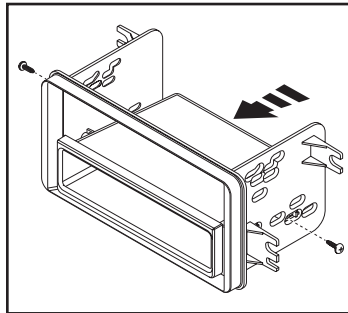

(Figure B)

5. Locate the factory wiring harness and antenna plug in the dash and make all necessary wire connections to the radio. Metra recommends using the proper mating adapters from Metra and/or AXCESS. Test the radio for proper operation.
6. Mount the new radio assembly into the dash.
7. Reassemble the dash in the reverse order of disassembly.

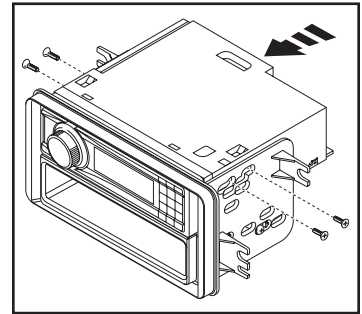

(Figure C)