



Mazda 3 2014-up*

KIT FEATURES

- ISO DDIN radio provision*
- Painted matte black

*This kit can only be used with an ISO DDIN radio with an “L” shaped chassis design, with the radio chassis at the bottom of the screen. As of this writing, only the Alpine INE-W967HD (discontinued, replaced by INE-W977HD), iLX-107, and iLX-207 have this design.

KIT COMPONENTS

- A) Radio trim panel (a) • B) Radio trim panel (b) • C) Radio housing base • D) Radio brackets • E) Radio support bracket • F) (4) Panel clips
- G) (2) #8 x 1/2” Phillips screws

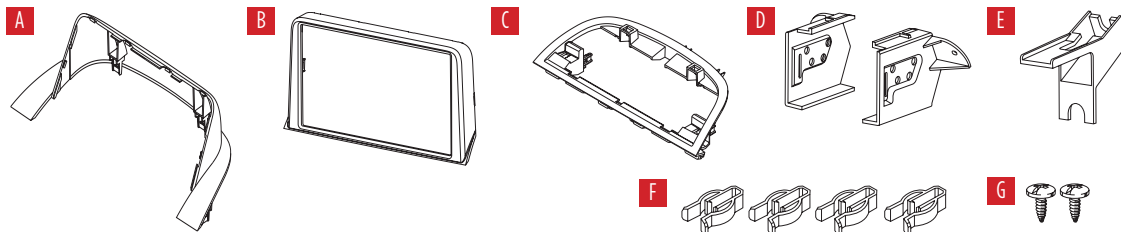

TABLE OF CONTENTS

Dash Disassembly	2
Kit Preparation	2
Kit Assembly	3

WIRING & ANTENNA CONNECTIONS (sold separately)

Wiring Harness: 70-7903L (without amp)

Antenna Adapter: 40-HD10L

Steering wheel control interface: ASWC-1 & AX-MAZ28SWC-6V (will also retain backup camera)

TOOLS REQUIRED

- Panel removal tool • Phillips screwdriver
- 10mm Socket wrench • 1/8” drill bit

CAUTION! All accessories, switches, climate controls panels, and especially air bag indicator lights must be connected before cycling the ignition. Also, do not remove the factory radio with the key in the on position, or while the vehicle is running.

DASH DISASSEMBLY

1. Unclip and remove the dashboard trim panel above the glovebox. This panel will also include the middle a/c vents. (Figure A)
2. Remove (1) 10mm screw securing the radio, then unclip, unplug, and remove the radio. (Figure B)

Continue to Kit Preparation

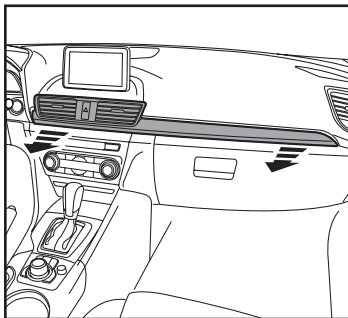

(Figure A)

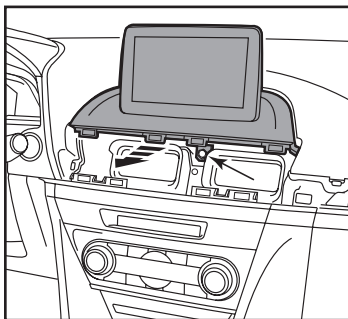

(Figure B)

KIT PREPARATION

1. Secure the *radio support bracket* to the sub-dash using the factory 10mm screw removed in dash disassembly. Directly above this is the factory radio support brace. Bend this towards the front of the vehicle to allow room for the aftermarket radio. (Figure A)
2. Remove the panel clips from the factory radio, then attach them onto the *radio housing base*. (Figure B)
3. Clip the *radio housing base* to the dash. (Figure C)

Continue to Kit Assembly

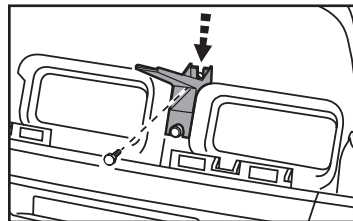

(Figure A)

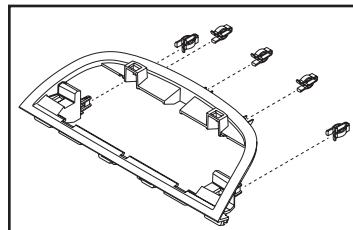

(Figure B)

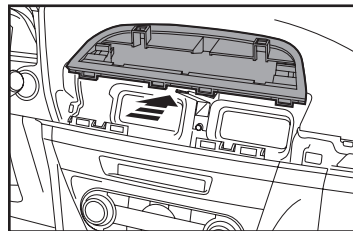

(Figure C)

KIT ASSEMBLY

1. Attach the (4) *panel clips* provided onto the *radio trim panel (a)*. (Figure A)
2. Attach the *radio brackets* to the radio using the screws supplied with the radio. (Figure B)
3. Locate the factory wiring harness and antenna connector in the dash and complete all necessary connections to the radio. Metra recommends using the proper mating adapter from Metra and/or Axxess. Test the radio for proper operation.

Note: The wiring harness and antenna connector are located in the passenger kick panel, except for the 2014 i-Sport.

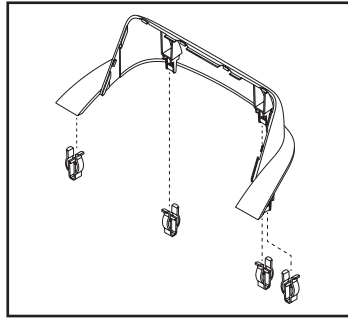

(Figure A)

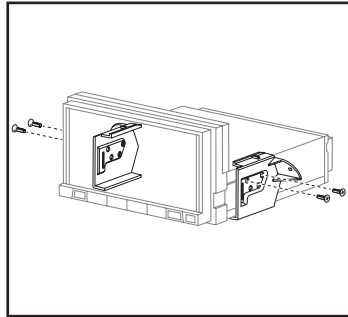

(Figure B)

4. Insert the radio into the sub-dash and secure it using the (2) Phillips screws provided. New screw holes will have to be drilled into the sub-dash. Either drive the screws in, or pre-drill the holes with a 1/8" drill bit.
5. Attach *radio trim panel (a)* to the assembly.
6. Starting from the bottom, attach *radio trim panel (b)* to the assembly.
7. Reassemble the dash in reverse order of disassembly to complete the installation.