



Jeep Grand Cherokee 1999-2004

KIT FEATURES

- ISO DDIN radio provision
- Painted matte black

KIT COMPONENTS

- A) Radio trim panel • B) Radio brackets • C) (2) Panel clips

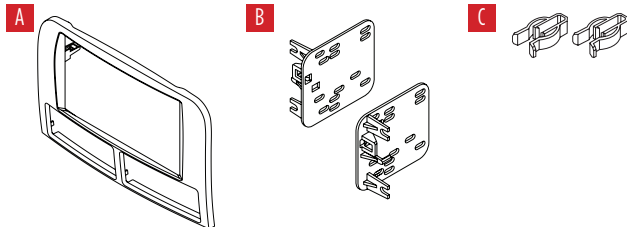

TABLE OF CONTENTS

Dash Disassembly	2
Kit Preparation	3
Kit Assembly	3

WIRING & ANTENNA CONNECTIONS (sold separately)

Wiring Harness: 70-1817 (99-01) • 70-6502 (02-04)
Antenna Adapter: N/A (99-01) • 40-CR10 (02-04)

TOOLS REQUIRED

- Panel removal tool • Phillips screwdriver
- Cutting tool • Grinding tool

CAUTION! All accessories, switches, climate controls panels, and especially air bag indicator lights must be connected before cycling the ignition. Also, do not remove the factory radio with the key in the on position, or while the vehicle is running.

DASH DISASSEMBLY

1. Unclip and remove the radio trim panel. (Figure A)
2. Remove (4) Phillips screws securing the radio, then unplug and remove the radio.

Continue to Kit Preparation

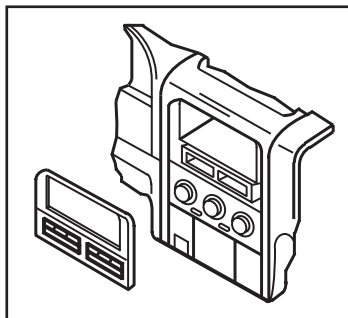

(Figure A)

KIT PREPARATION

1. Carefully grind or cut away the (4) plastic welded tabs securing the a/c vents to the radio trim panel, then remove the vents. (Figure A)
2. Trim the top of the a/c vents. (Figure B)
3. Attach the a/c vents to the radio trim panel, then secure them by either gluing them, or plastic welding them in place.

Note: Once the radio trim panel is secured to the vehicle, this will also hold the vents in place.

4. Attach the (2) *panel clips* provided onto the *radio trim panel*.
5. Cut the sub-dash to allow room for the radio assembly. (Figure C)

Continue to Kit Assembly

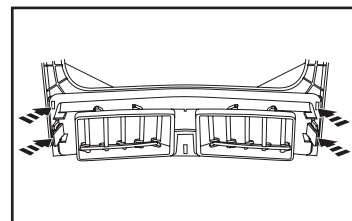

(Figure A)

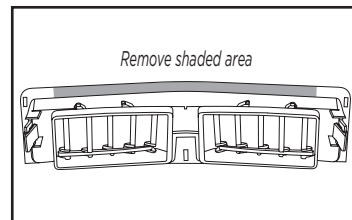

(Figure B)

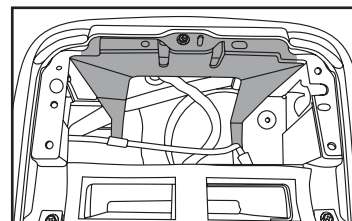

(Figure C)

KIT ASSEMBLY

1. Secure the *radio brackets* to the radio using the screws supplied with the radio. (Figure A)
2. Locate the factory wiring harness and antenna connector in the dash and complete all necessary connections to the radio. Metra recommends using the proper mating adapter from Metra and/or Axxess. Test the radio for proper operation.
3. Secure the radio assembly to the dash using the factory screws.
4. Snap the *radio trim panel* over the radio assembly to complete the installation.

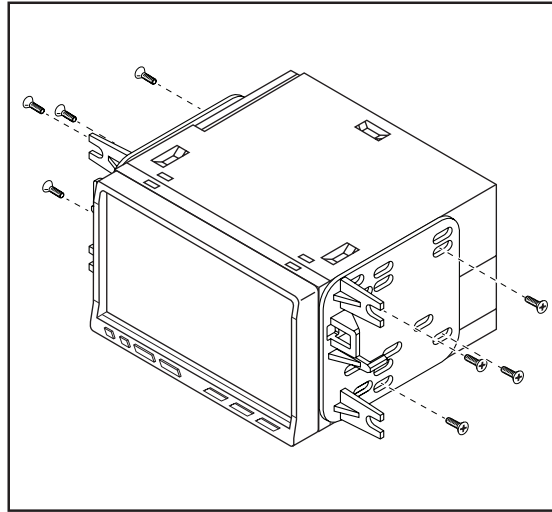

(Figure A)