



## Lincoln Navigator 2007-2014

Intended for 4x4 models without factory NAV

### KIT FEATURES

- ISO DDIN radio provision
- Painted silver to match the factory appearance

### KIT COMPONENTS

- A) Radio trim panel
- B) Radio brackets

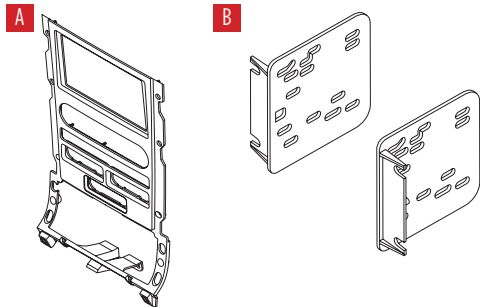

### TABLE OF CONTENTS

Dash Disassembly .....	2
Kit Preparation .....	3
Kit Assembly .....	3

### WIRING & ANTENNA CONNECTIONS (sold separately)

Wiring Harness:

Antenna Adapter: 40-CR10

### TOOLS REQUIRED

- Panel removal tool
- Phillips screwdriver
- 8mm, 7/32" and 9/32" socket wrench
- T-20 Torx driver

**CAUTION!** All accessories, switches, climate controls panels, and especially air bag indicator lights must be connected before cycling the ignition. Also, do not remove the factory radio with the key in the on position, or while the vehicle is running.

## DASH DISASSEMBLY

1. Unclip and remove the panel surrounding the shifter. (Figure A)
2. Remove (2) 9/32" screws from the bottom of the radio/climate control trim panel, and then unclip and remove. (Figure B)
3. Remove (4) 9/32" screws securing the radio and then remove.

### Radio/climate control trim panel disassembly:

4. Remove (4) Torx T-20 screws and remove the factory pocket/ ashtray assembly from the factory dash panel. (Figure C)
5. Remove (4) 7/32 screws and remove the factory climate controls. (Figure C)
6. Remove all the factory button assembly's from the factory dash panel. (Figure C)
7. Remove (6) Torx T-20 screws and (4) push-nuts to remove the center panel from the factory dash panel. (Figure C)

Continue to Kit Preparation

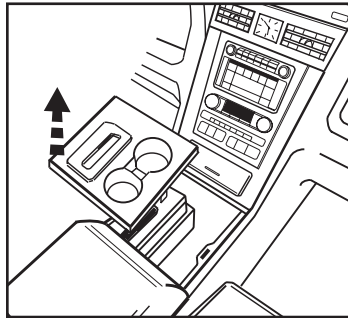

(Figure A)

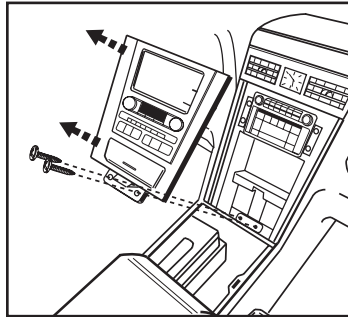

(Figure B)

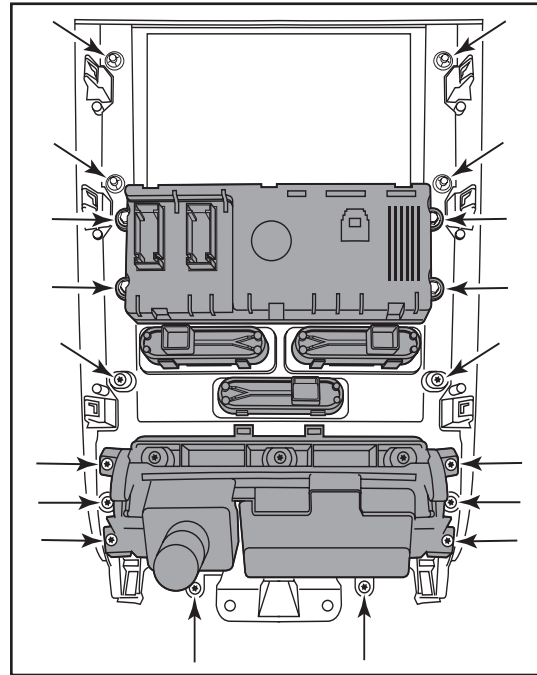

(Figure C)

## KIT PREPARATION

1. Place the *radio trim panel* into the factory dash panel and secure with the (6) T-20 screws and (4) push nuts removed in Dash Disassembly. (Metra recommends a small 8mm socket for pressing them on). (Figure A)
2. Mount the pocket, climate controls and buttons to the Metra *radio trim panel* using the factory hardware. (Figure B)

Continue to Kit Assembly

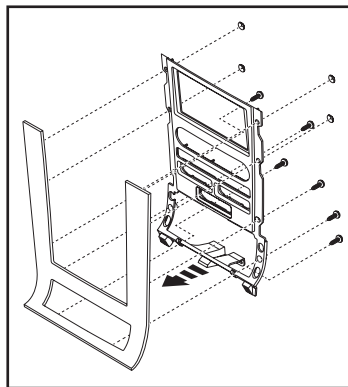

(Figure A)

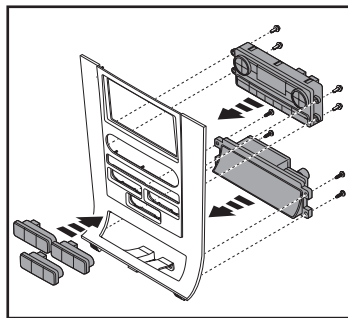

(Figure B)

## KIT ASSEMBLY

1. Attach the *radio brackets* to the radio using the screws supplied with the radio. (Figure A)
2. Locate the factory wiring harness and antenna connector in the dash, and complete all necessary connections to the radio. Metra recommends using the proper mating adapter from Metra and/or AXCESS. Test the radio for proper operation.
3. Secure the radio into the dash opening using the factory hardware.
4. Snap the *radio trim panel* over the radio and then reassemble the dash in reverse order of disassembly.

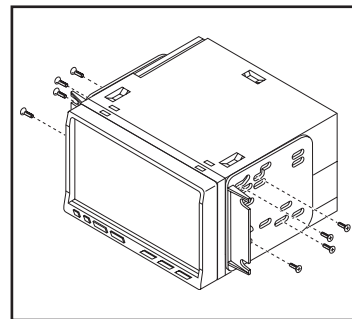

(Figure A)