



Installation instructions for 82-3043

Chevrolet Blazer 1995-1998, S10 1994-1998 GMC Jimmy 1995-1998, Sonoma 1994-1998 82-3043

KIT FEATURES

- Adapts 5 1/4" or 6 1/2" speakers to the front door locations

KIT COMPONENTS

- A) [Speaker adapter plates](#) • B) (2) Foam strips • C) (8) #14 x 1/2" Phillips screws



WIRING CONNECTIONS (sold separately)

Wiring Harness: • 72-4500

TOOLS REQUIRED

- Phillips screwdriver • Socket wrench • Window crank removal tool

CAUTION! Metra recommends disconnecting the negative battery terminal before beginning any installation, unless the vehicle manufacturer recommends against so. Please check with your local Dealership for more information. All accessories, switches, climate controls panels, and especially air bag indicator lights must be connected before reconnecting the battery or cycling the ignition. Also, do not remove the factory radio with the key in the on position, or the vehicle running. It would be best to remove the key from the ignition and then wait a few seconds before removing the factory radio.

Door Disassembly

S-10 Blazer, S-10 Pickup, S-15 Jimmy, Sonoma 1994-1997:

1. Remove (1) screw and (1) plastic rivet from the door lock assembly and remove the door lock trim. Unclip the plastic insert in the door pull handle and remove (2) screws exposed. Remove (1) plastic rivet from the top of the door panel. Using a window crank removal tool, release the spring clip securing the window crank handle and remove.

Note: (For models with power windows, remove the control trim panel by pulling the panel up and sliding it forward).

Unclip the perimeter of the door panel and remove (Figure A)

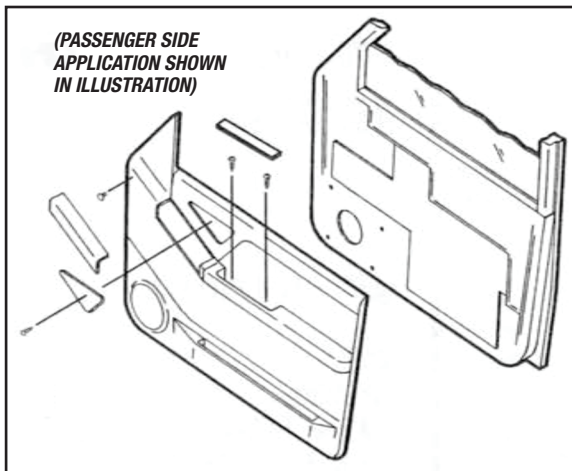

(Figure A)

Blazer, Jimmy, S-10 Pickup, Sonoma 1998:

1. Remove (1) 9/32" screw from the door pull handle. Remove (1) Phillips screw from the door latch. Unclip the perimeter of the door panel and remove.

Kit Assembly

1. Peel away the paper backing from the *foam strip* and attach it to the front of the *speaker adapter plate*. (This will enhance the performance of the aftermarket speaker). (Figure A)
2. Mount the aftermarket speaker to the *speaker adapter plate* with the screws supplied with speaker. (Figure B)
3. Re-connect the battery terminal and test the speaker for proper operation. Mount the assembly to the door frame with (4) #14 x 1/2" Phillips screws supplied. (Figure C)

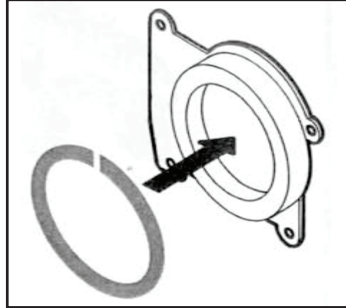

(Figure A)

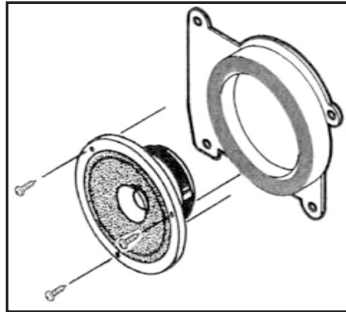

(Figure B)

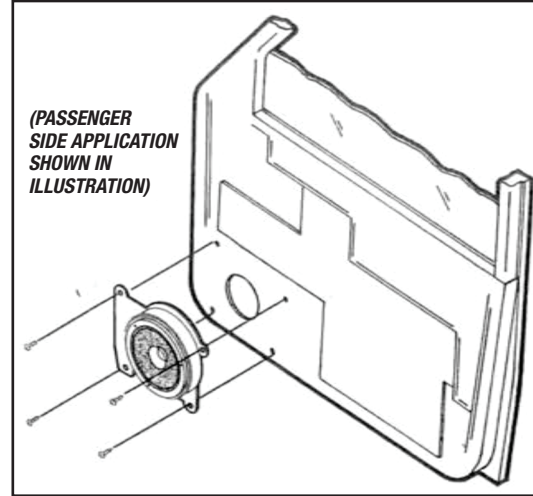

(Figure C)