



## INSTALLATION INSTRUCTIONS FOR PART 82-1011

### APPLICATIONS

# Jeep Wrangler 1997-2006 82-1011

### KIT FEATURES

---

- 82-1011 (adapts 4" x 6" speaker to dash location)

### KIT COMPONENTS

---

- A) 82-1011 Speaker adaptor plates • B) (8) #8 x 1/2" Phillips screws
- 

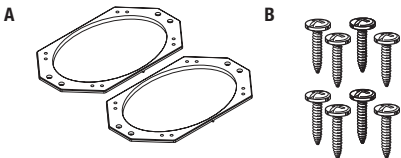

### WIRING & ANTENNA CONNECTIONS (sold separately)

---

Wiring Harness: • 72-6512 speaker harness

Antenna Adapter: • Not required

### TOOLS REQUIRED

---

- Phillips screwdriver

**CAUTION:** Metra recommends disconnecting the negative battery terminal before beginning any installation. All accessories, switches, and especially air bag indicator lights must be plugged in before reconnecting the battery or cycling the ignition.

**NOTE:** Refer to the instructions included with the aftermarket radio.

## Dash Disassembly

**Note:** Parts 82-1011, 82-1012, 82-1013 installation directions cross reference. Use the following instructions for each dash location.

1. Remove (2) Phillips screws securing the speaker grille panel. (Figure A)
2. Unclip panel and remove. (Figure A)

*Continue to kit preparation*

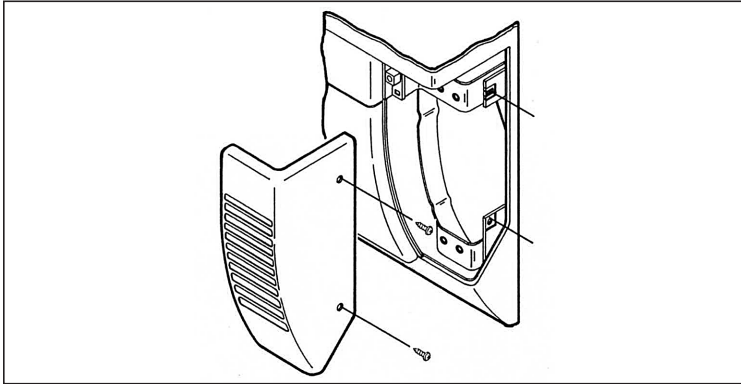

(Figure A)

## Kit Preparation

1. Mount aftermarket speaker to the speaker adaptor plate with the screws supplied with the speaker. (Figure A)

*Continue to kit assembly*

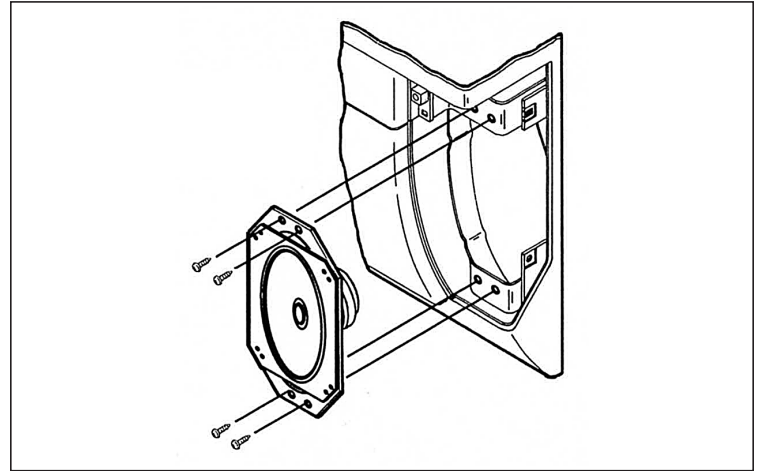

(Figure A)

